

(19) **DANMARK**

(10) **DK/EP 2871289 T3**



(12) **Oversættelse af
europæisk patentskrift**

Patent- og
Varemærkestyrelsen

-
- (51) Int.Cl.: **E 02 D 27/42 (2006.01)**
- (45) Oversættelsen bekendtgjort den: **2017-01-30**
- (80) Dato for Den Europæiske Patentmyndigheds bekendtgørelse om meddelelse af patentet: **2016-10-19**
- (86) Europæisk ansøgning nr.: **14181648.8**
- (86) Europæisk indleveringsdag: **2014-08-20**
- (87) Den europæiske ansøgnings publiceringsdag: **2015-05-13**
- (30) Prioritet: **2013-11-08 US 201314075014**
- (84) Designerede stater: **AL AT BE BG CH CY CZ DE DK EE ES FI FR GB GR HR HU IE IS IT LI LT LU LV MC MK MT NL NO PL PT RO RS SE SI SK SM TR**
- (73) Patenthaver: **Siemens Aktiengesellschaft, Wittelsbacherplatz 2, 80333 München, Tyskland**
- (72) Opfinder: **Jensen, Martin Johan Smith, Brejning Søndergade 31, 7080 Børkop, Danmark**
- (74) Fuldmægtig i Danmark: **Zacco Denmark A/S, Arne Jacobsens Allé 15, 2300 København S, Danmark**
- (54) Benævnelse: **Nivellering af et tårn**
- (56) Fremdragne publikationer:
EP-A1- 2 636 899

DESCRIPTION

[0001] The invention describes a levelling arrangement for a tower; a method of providing a level mounting interface for a tower; a method of erecting a wind turbine tower; and a wind turbine tower assembly, such as generally known from EP 2 636 899 A.

[0002] A tower such as a wind turbine tower must be secured to a foundation in some way. In the case of a concrete foundation, for example, the lower section of a wind turbine tower is usually anchored to the foundation using anchor bolts that were previously embedded in the concrete. The "heads" of the anchor bolts are usually fixed in steel anchor plates that were laid horizontally in the foundation and covered with a suitably thick layer of concrete, so that most of each anchor bolt is embedded and only a relatively short section of each anchor bolt remains protruding vertically upward from the surface of the foundation.

[0003] However, it is very difficult to achieve a perfectly horizontal upper surface of foundation. At the same time, it is necessary to ensure that a lower tower section is placed horizontally, otherwise the resulting unbalanced loading would stress the tower structure any may lead to irreparable damage. In some known approaches, a horizontal alignment is achieved by first estimating where a height adjustment might be necessary, placing shims over the appropriate anchor bolt ends, and repeating the process until the corrections are deemed sufficient. The tower flange of the lowest tower section can then be lowered into place over the "corrected" anchor bolt ends. If the correction was performed properly, the lower surface of the tower flange will lie in the desired horizontal plane. However, such a procedure is very time-consuming, since great effort must be invested to determine what corrections are necessary and whether the corrections are sufficient before putting the lowest tower section into place.

[0004] In another approach, a levelling ring can be used as an intermediate layer between the foundation and the tower flange. Such a levelling ring is arranged to fit over the anchor bolts, and grout is pushed under the levelling ring in various places until an upper surface of the levelling ring is essentially horizontal. Once the grout has hardened, the bottom tower section is lowered into place over the anchor bolts and these are secured. However, this approach is also difficult to get right, since it is not easy to achieve a perfectly horizontal alignment of the levelling ring. This is because a tower can have a very large lower diameter, depending on the generating capacity of the wind turbine, and a levelling ring must be at least as wide. The diameter at the tower base can be in the range of 3.0 to 6.0 m, for example about 4.0 m for a 3 Megawatt wind turbine. Since a levelling ring must also be made of a strong material such as steel, it is a very heavy component and therefore difficult to manipulate, particularly when a very precise levelling adjustment must be made in the millimetre range.

[0005] It is therefore an object of the invention to provide an improved way of providing a horizontal mounting surface for a wind turbine tower.

[0006] This object is achieved by the levelling arrangement of claim 1; by the method of claim 10 of providing a level mounting surface for a tower; by the method of claim 14 of erecting a wind turbine tower; and by the wind turbine tower assembly of claim 15.

[0007] According to the invention, the levelling arrangement for a tower comprises a levelling ring realised for placement between a tower foundation and the tower; and a levelling apparatus, which levelling apparatus comprises a connection means for detachably connecting to the levelling ring during a levelling procedure, and a number of adjustment legs, wherein an adjustment leg is realised to effect a displacement of the levelling ring relative to the tower foundation during the levelling procedure.

[0008] An advantage of the levelling arrangement according to the invention is that the adjustment legs of the levelling apparatus can be used to achieve a very precise horizontal alignment of the levelling ring, which in turn will present an essentially horizontal connection surface for a tower. The alignment of the levelling ring can be performed in a very simple and straightforward manner.

[0009] According to the invention, the method of providing a level mounting interface for a tower comprises the steps of detachably connecting a levelling ring to a levelling apparatus; arranging the levelling apparatus over a tower foundation; operating the levelling apparatus to effect a displacement of the levelling ring relative to the tower foundation until the levelling ring presents a level mounting surface; bonding the levelling ring to the tower foundation; and disconnecting and removing the levelling apparatus from the levelling ring.

[0010] An advantage of the method according to the invention of providing a level mounting surface is that an essentially horizontal connection surface for a tower can be achieved in a quick and accurate manner. Furthermore, the levelling apparatus can be quickly and easily connected to the levelling ring, and just as easily disconnected from the levelling ring again once this is

secured on the foundation.

[0011] According to the invention, the method of erecting a wind turbine tower comprises the steps of providing a level mounting interface for the wind turbine tower using the method according to the invention of providing a level mounting interface that comprises a levelling ring that is connected to a tower foundation, and a plurality of connectors protruding through the levelling ring. The method further comprises the step of connecting a lower tower flange of the wind turbine tower to the connectors of the level mounting interface.

[0012] An advantage of the method according to the invention of erecting a wind turbine tower is that the steps are straightforward to carry out. Particularly the step of providing a level mounting interface can be carried out relatively quickly. The precisely levelled mounting interface then provides a safe and load-efficient basis to which the lower tower flange can be connected.

[0013] According to the invention, the wind turbine tower assembly comprises a tower foundation; a levelling ring levelled using a levelling apparatus according to the invention and connected to the tower foundation; and a wind turbine tower comprising a lower tower flange bolted to the levelling ring.

[0014] An advantage of the wind turbine tower assembly according to the invention is that the loads can be transferred safely and evenly into the tower foundation. Structural damage owing to uneven loading is effectively avoided, so that the lifetime of the tower can be favourably long, in contrast to a tower assembly erected on a foundation prepared using a prior art levelling procedure.

[0015] Particularly advantageous embodiments and features of the invention are given by the dependent claims, as revealed in the following description. Features of different claim categories may be combined as appropriate to give further embodiments not described herein.

[0016] In the following, without restricting the invention in any way, it may be assumed that the tower is a wind turbine tower. Similarly, it may be assumed in the following that a foundation comprises a concrete foundation into which an annular arrangement of anchor bolts has been embedded using any suitable technique, for example by embedding anchor plates in the wet foundation and allowing this to harden. In the following, the expression "providing a level mounting interface for a tower" may be referred to more simply as a "levelling procedure". Also, the terms "levelling apparatus" and "levelling fixture" may be used interchangeably.

[0017] The "adjustment leg" can be realised in any suitable way. The function of the adjustment leg is to hold and simultaneously adjust the orientation of the levelling apparatus, so that the levelling ring can be aligned as desired. For example, a levelling apparatus can comprise one or more adjustment legs arranged at a distance outward from the future tower flange position, and some means of securing a levelling ring to these adjustment legs. For example, a suitable framework might be used as a levelling apparatus, with some means of securing the levelling ring during a levelling procedure, and some means of displacing the levelling ring relative to the tower foundation during the levelling procedure. In a preferred embodiment of the invention, an adjustment leg comprises a foot for resting on the foundation and a gripper for gripping the levelling apparatus. For example, a single adjustment leg can be arranged essentially at the geometric centre of the future tower flange position. Such a single adjustment leg can hold the levelling ring using a suitable construction that can also tilt in any direction to achieve the desired horizontal alignment.

[0018] In a particularly preferred embodiment of the invention, the levelling apparatus comprises three adjustment legs. Three fixed points can be used to define a horizontal plane, so that the use of three adjustment legs allows a favourably simple construction of the levelling apparatus. In a preferred embodiment of the invention, an adjustment leg of the levelling apparatus comprises a height adjustment means for effecting the displacement of the levelling ring relative to the fixed point associated with that adjustment leg, and therefore also relative to the tower foundation. For example, when three adjustment legs (standing on three "feet" in a region bounded by the future tower flange) are used to hold the levelling ring, their height adjustment means can be used to obtain an essentially horizontal orientation of the levelling ring. By this is meant that an upper surface of the levelling ring, which will later connect to a lower surface of a tower flange, is essentially horizontal.

[0019] A visual inspection or assessment of the quality of the horizontal alignment may be made by one or more operators observing and controlling the levelling arrangement. Vertical displacements of the adjustment legs can be made manually, for example by using a controller to actuate a hydraulic piston of an adjustment leg. However, in a preferred embodiment of the invention, the levelling arrangement comprises an offset detector for detecting an offset between an actual position of the levelling ring and a desired position of the levelling ring. An offset detector is preferably used to determine any offset between the levelling

ring and the horizontal plane in which the lower tower flange should lie. Such an offset detector can issue appropriate information to controllers of the adjustment legs to effect the desired displacements. For example, at a point corresponding to an adjustment leg, the levelling ring may be deemed to be too far away from the foundation, so that the levelling ring must be lowered by that adjustment leg by a certain offset. Equally, at a point corresponding to an adjustment leg, the levelling ring may be deemed to be too close to the foundation, so that it must be raised by an offset. Of course, the levelling ring may be deemed to have a satisfactory distance to the foundation at a point corresponding to an adjustment leg, so that a vertical displacement of the levelling ring is not required by that adjustment leg.

[0020] The connection means between the adjustment legs and the levelling ring can be made in any suitable manner, for example by using an appropriate framework as indicated above. However, in a particularly preferred embodiment of the invention, the levelling apparatus comprises a cylindrical body. This cylindrical body preferably has a diameter that is similar to the diameter of the levelling ring and the tower flange. In a further particularly preferred embodiment of the invention, the connection means of the levelling apparatus for detachably connecting to the levelling ring comprises an annular arrangement of through-holes. To this end, the connection means preferably comprises a flange or similar element in which the through-holes could be formed. The levelling ring preferably also has an essentially identical annular arrangement of bores or through-holes, i.e. the same number of through-holes with the same spacing and the same bore. This allows the levelling ring to be connected to the cylindrical body of the connection means simply by using standard nut-and-bolt fasteners.

[0021] Another advantage of using such a cylindrical body is that a lower tower section of the same type that will be used in the future tower could be used directly as the connection means. A lower tower section generally already has a cylindrical body and a flange with an annular arrangement of through-holes.

[0022] A significant advantage of using a cylindrical body as connection means is that the levelling ring can preferably comprise a plurality of levelling ring segments. In other words, the levelling arrangement according to the invention makes it easy to use a segmented levelling ring, with all its transport- and weight-associated advantages. The levelling ring segments can be realised to abut each other, or their outer or "short" ends can be made to fit together in a stepped joint, a tongue-and-groove joint, or any other appropriate joint.

[0023] In a preferred embodiment of the invention, the step of bonding the levelling ring to the tower foundation comprises the step of filling any spaces between levelling ring and tower foundation with a grout layer. To this end, once the levelling ring has been aligned in the desired horizontal plane, any remaining spaces or gaps between the levelling ring and the upper surface of the foundation are preferably filled with grout, since this is a malleable material and can be pressed into essentially any gap, and when hardened, the resulting "grout bed" can act to effectively transfer loads from the tower and into the foundation. Since the levelling ring itself offers a relatively large surface area, and since the grout can be spread over the entire area under the levelling ring, the arrangement according to the invention favourably allows the use of a low-strength grout. This can present a significant advantage in a country in which the use of high-strength grout is not approved in a wind turbine tower foundation. In such countries, when using the known methods for erecting a wind turbine tower, it has been necessary to make the lower tower flange quite wide in order for the structural loads to be safely transferred into the foundation by the low-strength grout. However, a wide tower flange is associated with transport difficulties and considerable expense, as will be known to the skilled person. The levelling arrangement according to the invention allows a low-strength grout to be used, while at the same time allowing the tower flange width to be kept favourably narrow. Furthermore, since the levelling ring can be provided in segments, transportation problems do not arise.

[0024] In a particularly preferred embodiment of the invention, the annular arrangement of through-holes in the connection means (and levelling ring) corresponds to a tower flange annular through-hole arrangement. The advantage of such a realisation is that the bolts that will be used to connect the levelling ring to the tower flange may initially be used to connect the levelling ring to the levelling apparatus, and can then remain in position after the levelling apparatus has been disconnected from the levelling ring, after the levelling procedure has been carried out. Preferably, the bolts are placed such that the bolt head is "underneath" the levelling ring, and the threaded bolt body extends vertically upward through the levelling ring. After the levelling procedure and removal of the levelling apparatus, the levelling ring remains on the grout bed, with an annular ring of bolts extending vertically upward in readiness to receive the tower flange.

[0025] As explained above, a wind turbine tower is usually anchored to the foundation using anchor bolts that are embedded in the concrete foundation. The "heads" of the anchor bolts are usually fixed in steel anchor plates that are laid horizontally in the foundation and covered with concrete, so that most of each anchor bolt is embedded, and only a portion of each anchor bolt protrudes vertically upward from the foundation. In the prior art solutions, a horizontal alignment of the tower flange is achieved using shims placed over the anchor bolt ends, and the tower flange of the lowest tower section is put into place over the anchor

bolt ends. In a preferred embodiment of the invention, the step of arranging the levelling apparatus over the tower foundation comprises mating the levelling ring with anchor bolt connectors protruding from the tower foundation. To this end, in addition to the annular arrangement of through-holes that will mate with the through-holes of the tower flange, the levelling ring has an additional annular arrangement of through-holes for the anchor bolts. To this end, when two rings of anchor bolts are to be used, these are preferably arranged in an outer annular arrangement and an inner annular arrangement, whereby the diameter of the outer annular arrangement is larger than its prior art counterpart, and the diameter of the inner annular arrangement is smaller than its prior art counterpart.

[0026] Other objects and features of the present invention will become apparent from the following detailed descriptions considered in conjunction with the accompanying drawings. It is to be understood, however, that the drawings are designed solely for the purposes of illustration and not as a definition of the limits of the invention.

Fig. 1 shows a levelling apparatus of a first embodiment of a levelling arrangement according to the invention;

Fig. 2 shows the levelling arrangement of Fig. 1 in place over a tower foundation in an initial stage of a levelling procedure;

Fig. 3 shows the levelling arrangement of Fig. 1 in a subsequent stage of the levelling procedure;

Fig. 4 illustrates the principle of operation of the levelling arrangement according to the invention;

Fig. 5 shows level mounting interface obtained using the levelling arrangement according to the invention;

Fig. 6 is a schematic representation of a cross-section through a lower tower section and through a level mounting interface obtained using the levelling arrangement according to the invention;

Fig. 7 shows a wind turbine tower assembly according to an embodiment of the invention.

[0027] In the diagrams, like numbers refer to like objects throughout. Objects in the diagrams are not necessarily drawn to scale.

[0028] Fig. 1 shows a levelling apparatus 10 of a first embodiment of a levelling arrangement according to the invention, in a view from below or underneath. The levelling apparatus 10 comprises an essentially cylindrical body 100 with a diameter that is similar to the diameter of a lower tower segment for which the levelling arrangement is to be used to provide a level mounting interface. The levelling apparatus 10 comprises a lower flange 101 to which a levelling ring 2 will later be connected. The lower flange 101 shows two annular rings of through-holes 103. These correspond to one or more annular rings of through-holes in the levelling ring, and also to one or more annular rings of through-holes of the tower flange, as will become clear in the following. The levelling apparatus 10 also comprises three adjustment legs 12 that are used to bring the lower flange 101 (and therefore also the levelling ring) into a horizontal plane, so that a horizontally level mounting interface can be obtained in a quick and straightforward manner for a tower such as a wind turbine tower. Each adjustment leg 12 has a relatively wide "foot" 121 that rests on the ground. Furthermore, each adjustment leg 12 is firmly secured to the cylindrical body 100 of the levelling apparatus 10, in this embodiment the levelling apparatus 10 comprises gripper elements 120 that connect the adjustment legs 12 to the cylindrical body 100. Each adjustment leg 12 is realised to be extendable in a vertical direction, as indicated by the vertical arrow V. Each leg 12 can be independently actuated, so that even if the feet 121 are positioned in a plane that is not horizontal, the flange 101 (and therefore also the levelling ring) can be brought into a horizontal plane.

[0029] Fig. 2 shows a levelling arrangement 1 with the levelling apparatus 10 of Fig. 1 in place over a tower foundation 3 in an initial stage of a levelling procedure. Here, the feet 121 of the adjustment legs 12 are resting on the upper surface of the foundation 3 in a region corresponding to the interior of the tower that is to be erected on the foundation 3. The diagram shows a levelling ring 2 connected to the lower flange 101 by means of ring bolts 201. In a previous foundation preparation procedure, anchor bolts 301 have been embedded in the foundation 3 such that a portion of each anchor bolt 301 extends vertically upward through the foundation surface. The anchor bolts 301 are arranged in an annular ring formation corresponding to an annular arrangement of through-holes 203 in the levelling ring 2. In a first stage, the adjustment legs 12 of the levelling apparatus 10 are extended so that the lower flange 101 and levelling ring 2 are at a distance above the foundation.

[0030] Fig. 3 shows the levelling arrangement 1 of Fig. 1 in a subsequent stage of the levelling procedure. This diagram also shows that the levelling ring 2 can comprise a number of ring segments 20. Here, the adjustment legs 12 of the levelling apparatus 10 have been retracted so that the cylindrical body 100 has been lowered towards the foundation 3, and so that the anchor bolts 301 of the foundation 3 can pass through the through-holes 203 in the levelling ring 2. This can be regarded as a first rough alignment step. A precise levelling step follows, and is explained with the aid of Fig. 4, which illustrates the principle of

operation of the levelling arrangement 1 according to the invention. The levelling ring 2, which is bolted to the lower flange 101 of the levelling apparatus 10, is brought into a horizontal plane by means of the adjustment legs 12. Since each of the legs 12 is independently adjustable, and since three points are sufficient to uniquely define a horizontal plane, the plane containing the levelling ring 2 can be made essentially perfectly horizontal by actuating the adjustment legs 12 independently to lift or lower the levelling ring 2 as required, as indicated by the three displacements D1, D2, D3. A visual assessment made by an operator of the levelling fixture 10 may be enough to determine by how much each adjustment leg 12 must be actuated to obtain the desired horizontal alignment. Alternatively, as indicated here, an offset sensor 13 may be used to determine any offset between the levelling ring 2 and a horizontal plane. The offset detector 13 can issue appropriate information to controllers of the adjustment legs 12 to effect the desired displacements D1, D2, D3. For example, the levelling ring 2 may be deemed to have a satisfactory distance D2 to the foundation 3 at a point corresponding to a first adjustment leg. At a point corresponding to a second adjustment leg, the levelling ring 2 may be deemed to be too far away from the foundation 3, so that it must be lowered by a certain offset. Similarly, at a point corresponding to the third adjustment leg, the levelling ring 2 may be deemed to be too close to the foundation 3, so that it must be raised by an offset.

[0031] Returning to Fig. 3, once the levelling ring 2 is horizontal, the remaining space or gap between the levelling ring 2 and the foundation 3 is filled with a grout material 5. The pressure acting on the grout layer when the wind turbine has been installed is effectively the downward force divided by the area of the levelling ring 2. With the levelling arrangement 1 according to the invention, use of a low-strength grout material 5 is sufficient, since the relatively wide levelling ring 2 provides a favourably large area.

[0032] Fig. 5 shows a level mounting interface 2, 201 obtained using the levelling arrangement according to the invention. The levelling ring 2 has been bonded to the foundation by the anchor bolts 301 and securing nuts, and by the grout layer 5 between levelling ring 2 and foundation 3. After detaching and removing the levelling apparatus 10, the ring bolts 201 remain and extend vertically upward through the levelling ring 2. The diagram shows an embodiment in which two such annular formations of ring bolts 201 are ready for connection to a lower tower flange.

[0033] Fig. 6 is a schematic representation of a cross-section through a lower tower section 40 and through a level mounting interface 2, 201 obtained using the levelling arrangement according to the invention. The diagram shows an anchor plate 30 embedded in a foundation 3 and holding a vertical arrangement of anchor bolts 301 that extend upward through the surface of the foundation 3. Using a levelling apparatus 10 as described above, and a single annular arrangement of ring bolts 201, a levelling ring 2 was lowered into place to accommodate the anchor bolts 301 and then aligned in a horizontal plane. A grout layer 5 was subsequently introduced between the foundation 3 and the levelling ring 2. The levelling ring 2 was then secured to the anchor bolts 301 by means of fasteners 302 such as hex nuts 302. After removing the levelling apparatus 10, a lower tower section 40 with outer flange 401 was lowered into place such that the ring bolts 201 passed through an annular arrangement of through-holes in the tower flange 401. The ring bolts 201 were then secured by fasteners such as hex nuts 202. This diagram also illustrates the possibility of designing the lower tower section 40 to have only one lower tower flange 401, in this case an outer flange 401. This is made possible by the favourable transfer of forces from the tower through the level mounting interface 2, 201 and into the foundation 3.

[0034] Fig. 7 shows a wind turbine tower assembly 2, 3, 4 according to an embodiment of the invention. Here, the wind turbine tower 4 comprises several tower sections, and a lower tower section 40 is secured to a levelling ring 2 of a level mounting interface previously provided on a foundation 3. Any unevenness, i.e. any departure from the horizontal of the upper surface of the foundation 3 is corrected by the levelling ring 2 and a layer of grout 5, for example low-strength grout 5. A flange 401 of the lower tower section 40 is bolted to ring bolts 201 extending vertically upward through the levelling ring 2.

[0035] Although the present invention has been disclosed in the form of preferred embodiments and variations thereon, it will be understood that numerous additional modifications and variations could be made thereto without departing from the scope of the invention. For example, instead of separate anchor bolt rings and tower flange bolt rings, a bolt ring could comprise through-holes for anchor bolts alternating with through-holes for tower flange bolts. The levelling ring in this case could be connected to the cylindrical body with a tower bolt in every second through-hole, and lowered into place over the foundation such that each empty through-hole is lowered into place over an anchor bolt.

[0036] For the sake of clarity, it is to be understood that the use of "a" or "an" throughout this application does not exclude a plurality, and "comprising" does not exclude other steps or elements.

REFERENCES CITED IN THE DESCRIPTION

This list of references cited by the applicant is for the reader's convenience only. It does not form part of the European patent document. Even though great care has been taken in compiling the references, errors or omissions cannot be excluded and the EPO disclaims all liability in this regard.

Patent documents cited in the description

- [EP2636899A \[0001\]](#)

Patentkrav

- 5 **1.** Nivelleringsanordning (1) til et tårn (4), hvilken nivelleringsanordning (1) omfatter en nivelleringsring (2), der er udformet til anbringelse mellem et tårnfundament (3) og tårnet (4); og en nivelleringsindretning (10), hvilken nivelleringsindretning (10) omfatter
- et forbindelsesmiddel (101) til aftagelig forbindelse af nivelleringsindretningen (10) med nivelleringsringen (2) under en nivelleringsprocedure;
 - og et antal justeringsben (12), hvor et justeringsben (12) er udformet til at
- 10 bevirke en forskydning (D1, D2, D3) af nivelleringsringen (2) i forhold til tårnfundamentet (3) under nivelleringsproceduren.
- 2.** Nivelleringsanordning ifølge krav 1, hvor et justeringsben (12) omfatter en fod (121) til støtte på fundamentet (3) og en griber (120) til gribning af nivelleringsindretningen (10).
- 15
- 3.** Nivelleringsanordning ifølge krav 1 eller krav 2, hvor nivelleringsanordningen (10) omfatter tre justeringsben (12).
- 20
- 4.** Nivelleringsanordning ifølge et hvilket som helst af de foregående krav, hvor et justeringsben (12) af nivelleringsanordningen (10) omfatter et højdejusteringsmiddel til fremkaldelse af forskydningen (D1, D2, D3) af nivelleringsringen (2) i forhold til tårnfundamentet (3).
- 25
- 5.** Nivelleringsanordning ifølge et hvilket som helst af de foregående krav, hvor nivelleringsindretningen (10) omfatter et cylindrisk legeme (100).
- 6.** Nivelleringsanordning ifølge et hvilket som helst af de foregående krav, hvor forbindelsesmidlet (101) af nivelleringsindretningen (10) til aftagelig forbindelse med nivelleringsringen (2) omfatter en flange (101) med en ringformet anordning af gennemgangshuller (103).
- 30
- 7.** Nivelleringsanordning ifølge krav 6, hvor en ringformet anordning af gennemgangshuller (103) af nivelleringsringen (2) svarer til en ringformet gennemgangshulanordning af tårnflangen.
- 35

- 8.** Nivelleringsanordning ifølge et hvilket som helst af de foregående krav, hvor nivelleringsringen (2) omfatter en flerhed af nivelleringsringsegmenter (20).
- 5 **9.** Nivelleringsanordning ifølge et hvilket som helst af de foregående krav, omfattende en offset-detektor til detektering af offset mellem en faktisk position af nivelleringsringen (2) og en ønsket position af nivelleringsringen (2).
- 10 **10.** Fremgangsmåde til tilvejebringelse af en plan monteringsgrænseflade (2, 201) til et tårn (4), hvilken fremgangsmåde omfatter trinnene
- aftageligt at forbinde en nivelleringsring (2) med en nivelleringsindretning (10);
 - at anbringe nivelleringsindretningen (10) over et tårnfundament (3);
 - at betjene nivelleringsindretningen (10) til fremkaldelse af en forskydning (D1, D2, D3) af nivelleringsringen (2) i forhold til tårnfundamentet (3), indtil
- 15 nivelleringsringen (2) fremviser en i det væsentlige plan monteringsflade;
- at fæste nivelleringsringen (2) til tårnfundamentet (3); og
 - at adskille og fjerne nivelleringsindretningen (10) fra nivelleringsringen (2).
- 20 **11.** Fremgangsmåde ifølge krav 10, hvor trinnet at anbringe nivelleringsindretningen (10) over tårnfundamentet (3) omfatter at sammenpasse nivelleringsringen (2) med ankerboltkonnektorer (301), der rager frem fra tårnfundamentet (3).
- 25 **12.** Fremgangsmåde ifølge krav 10 eller krav 11, hvor trinnet at fæste nivelleringsringen (2) til tårnfundamentet (3) omfatter trinnet at fylde eventuelle mellemrum mellem nivelleringsringen (2) og tårnfundamentet (3) med et fugemasselag (5).
- 30 **13.** Fremgangsmåde ifølge krav 12, hvor fugemasselaget (5) omfatter et fugemassemateriale med lav styrke (5).
- 35 **14.** Fremgangsmåde til at rejse et vindmølletårn (4), hvilken fremgangsmåde omfatter trinnene
- at tilvejebringe en plan monteringsgrænseflade (2, 201) til et vindmølletårn (4) under anvendelse af fremgangsmåden ifølge et hvilket som helst af kra-

5 vene 10 til 13, hvilken plan monteringsgrænseflade (2, 201) omfatter en nivelleringsring (2) forbundet med et tårnfundament (3) og en flerhed af konnektorer (201), der rager frem gennem nivelleringsringen (2); og
- at forbinde en nedre tårnflange (401) med konnektorerne (201) af den plane monteringsgrænseflade (2, 201).

10 **15.** Vindmølletårnenhed (2, 3, 4), hvilken vindmølletårnenhed (2, 3, 4) omfatter
- et tårnfundament (3);
- en nivelleringsring (2), der er nivelleret under anvendelse af en nivelleringsanordning ifølge et hvilket som helst af kravene 1 til 9 og fæstet til tårnfundamentet (3); og
- et vindmølletårn (4) omfattende en nedre tårnflange (401), der er boltet til nivelleringsringen (2).

DRAWINGS

FIG 1

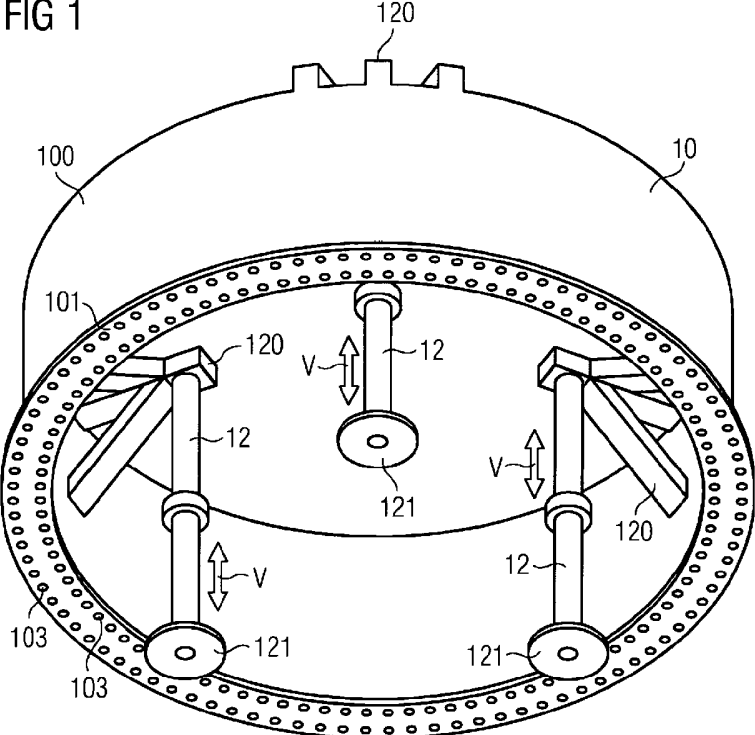

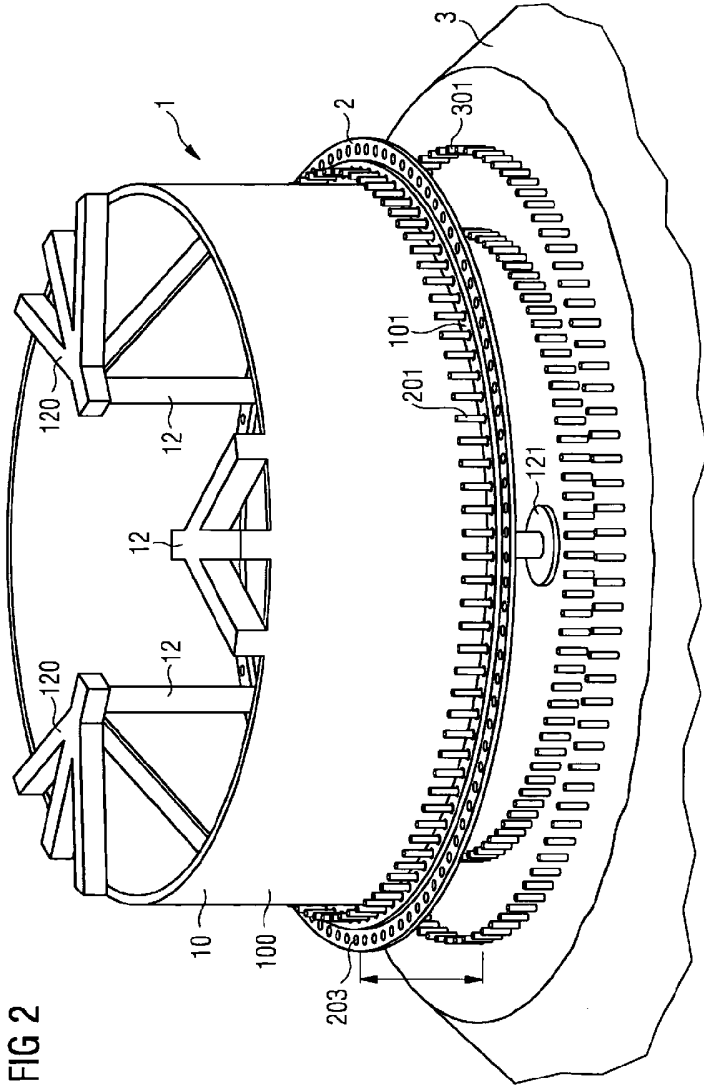

FIG 2

FIG 3

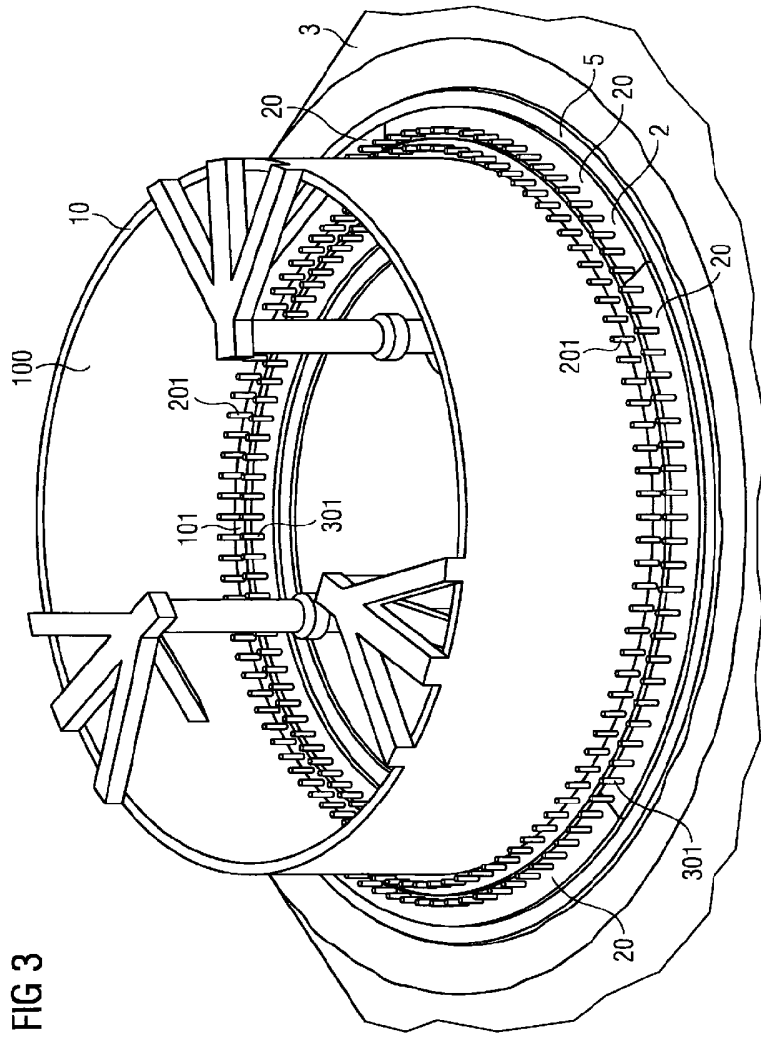
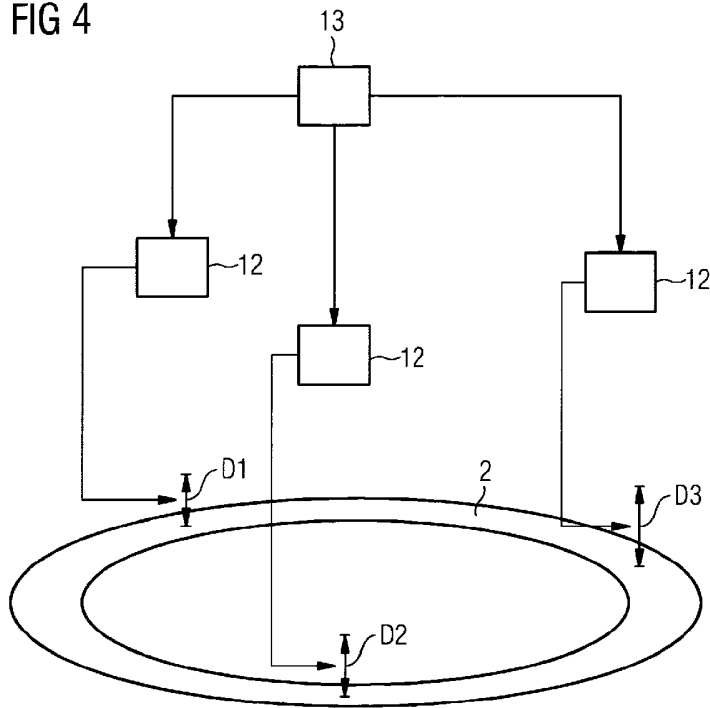

FIG 4



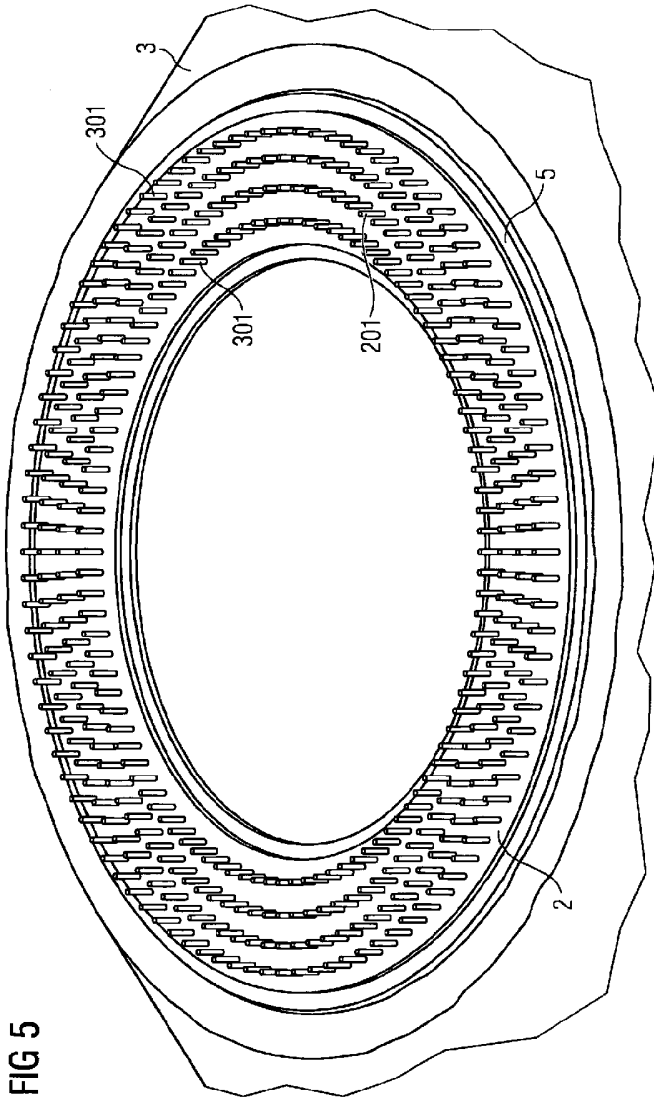

FIG 5

FIG 6

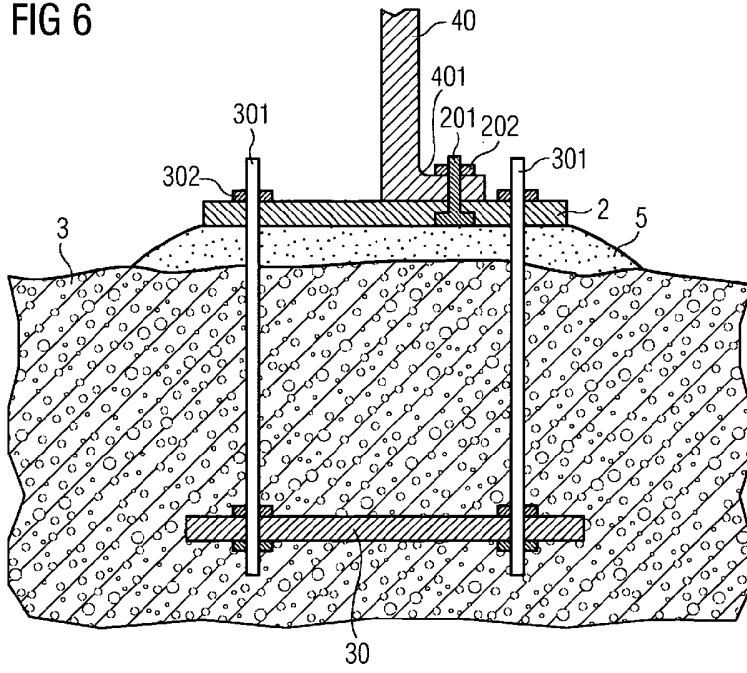

FIG 7

