

Jan. 17, 1967

L. M. ROTHENBERG, JR

3,298,260

SHEET METAL TOOL

Filed Oct. 12, 1965

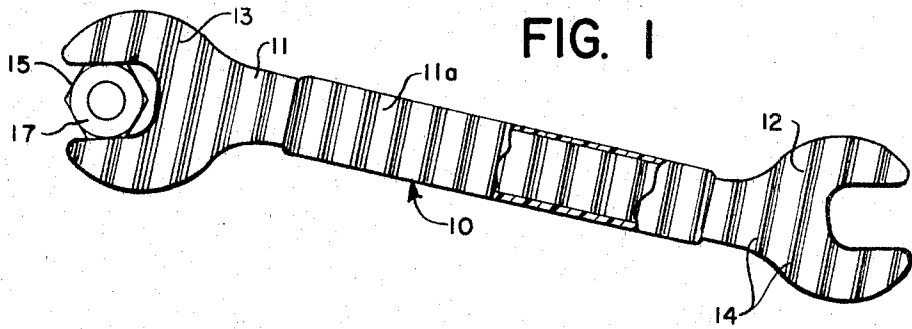

FIG. 1

FIG. 3

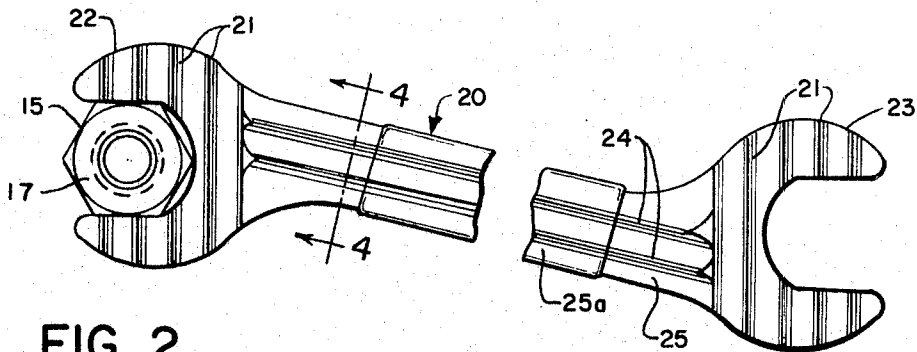

FIG. 2

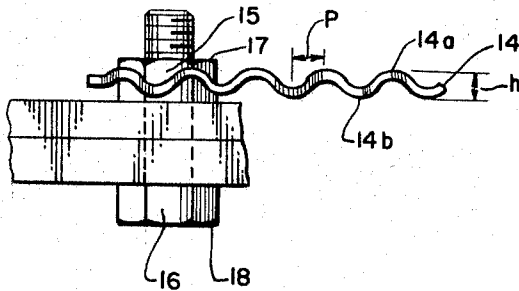
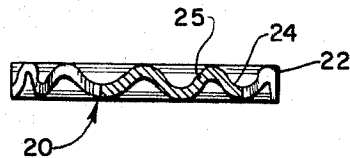

FIG. 4



INVENTOR  
LEE M. ROTHENBERG, JR.

BY

Mandeville & Schweitzer  
ATTORNEYS

1

2

3,298,260  
**SHEET METAL TOOL**  
 Lee M. Rothenberg, Jr., 174 Thornbury Road,  
 Scarsdale, N.Y. 10583  
 Filed Oct. 12, 1965, Ser. No. 495,160  
 8 Claims. (Cl. 31-177)

The present invention relates to improvements in tools, and is directed more specifically to novel and advantageous improvements in tools of the type formed out of sheet metal stock. The improvements of the present invention are applicable particularly to so-called open-end wrenches, but may find advantageous use in connection with wrenches of other types as well as in connection with certain other tools whose design and construction may accommodate the operative principles of the invention.

While most conventional wrenches and similar tools are manufactured by casting or forging procedures, in order to impart high strength and durability, there is a substantial existing market, and a potentially very large market, for wrenches formed by being stamped-out of sheet metal stock. The stamped-out wrenches, even of conventional design, are desirable because of their particularly low cost and have advantageous utilization where superior strength and durability are not primary requirements. A typical utilization of a stamped-out wrench is as a give-away accessory to accompany a home assembly kit (e.g., outdoor furniture, etc.) where the wrench can be used in conjunction with assembly or installation.

In accordance with the present invention, a stamped-out wrench is provided which is of novel and improved design and construction, imparting greatly improved strength and durability to the wrench. With a wrench of the improved construction, significant further savings can be realized over conventional stamped-out wrenches, in that equivalent strength and durability may be achieved with lighter gages of metal. Further, and perhaps more importantly, a stamped-out wrench incorporating the principles of the invention, by reason of its improved strength and durability, may be made to be competitive with the more conventional cast and forged wrenches over a broader range of applications than heretofore. It is additionally contemplated that the principles of the invention may be applied to the manufacture of inexpensive tool kits or sets, including several tools of stamped-out construction.

More specifically, the invention provides a stamped-out wrench or the like incorporating a novel and advantageous corrugated structural configuration imparting significant improved strength and durability while retaining the basic cost advantages of the stamped-out construction. The novel structural configuration of the invention takes advantage of the well-known strengthening characteristics of corrugated construction but, in addition and as a significant part of the inventive concept, utilizes the corrugated structural configuration in a way to provide for improved and stabilized gripping action between the wrench opening and the bolthead or nut. The improved gripping action is particularly important in improving the effective strength and durability of the wrench, because it materially reduces any tendency for the wrench to become tipped or skewed relative to the bolthead or nut when tightening force is applied thereto. Such a tendency to tilt or skew, which is characteristic of conventional stamped-out wrenches because of their thinness, effectively weakens the wrench jaws by introducing unusual stresses which cause the jaws to bend and spread. In accordance with the invention, the corrugated structure of the new wrench is so related to the size and shape of the jaws as to effectively stabilize the grip of

the wrench on a bolthead or nut by significantly increasing the effective thickness of the wrench jaws in relation to the actual thickness of the sheet material from which the jaws are formed.

5 For a better understanding of the above and other advantageous features of the invention, reference should be made to the following detailed description and to the accompanying drawing, in which:

10 FIG. 1 is a top plan view of an open-end wrench of stamped-out manufacture incorporating the improved structural configuration of the invention;

FIG. 2 is a fragmentary elevational view of the wrench of FIG. 1, illustrating the manner of its application to a standard hex nut;

15 FIG. 3 is a top plan view of a modified form of stamped-out, open-end wrench incorporating the improvements of the invention; and

FIG. 4 is a cross-sectional view of the wrench of FIG. 3, taken generally along line 4-4 thereof.

20 Referring now to the drawing, and initially to FIGS. 1 and 2 thereof, the reference numeral 10 designates generally a tool body which, for purposes of illustration, is shown to be a double, open-end wrench of generally conventional configuration, as viewed in plan. The 25 wrench body 10 includes an elongated handle portion 11 and jaws 12, 13 at either end, the opposed jaws typically being of appropriately graduated sizes such as 1/2 inch and 3/16 inch, for example. The illustrated wrench is stamped or otherwise cut out of sheet metal stock having a thickness, alloy composition, and physical characteristics suitable for the purpose intended. Usually, a low alloy sheet steel having a thickness on the order of .040 to .050 inch would be suitable for typical utilization. The handle portion may advantageously be provided with a vinyl or similar coating 11a for more comfortable gripping.

In accordance with the invention, the wrench body 10 is formed with structural corrugations 14 disposed generally transverse to the principal axes of the wrench jaws 12, 13 and of the handle portion 11. Customarily, and as in the wrench illustrated in FIG. 1, the respective jaws 12, 13 are disposed at a small angle to the principal axis of the wrench handle 11, and it may be expedient in some instances to align the corrugations at right angles to the handle and at an angle of slightly less than 90° to the axes of the wrench jaws, as shown in FIG. 1. As an advantageous alternative, the corrugations may be disposed at right angles to the jaw axes and at a smaller angle to the axis of the handle. In either instance, the corrugations advantageously may be uniform from one end to the other of the wrench. If appropriate, the wrench may be stamped out of previously corrugated metal stock, or the corrugations may be imparted to the metal stock in conjunction with the stamping operation.

55 Consistent with the principles of the invention, the structural corrugations 14 need not have any specific form. Advantageously, however, the corrugations may be generally rounded or sinusoidal in form, substantially as indicated in FIG. 2 of the drawings. In accordance with a specific aspect of the invention, the pitch *p* of the structural corrugations, which may be considered for the purposes of this description as the distance from the top of a crest 14a to the bottom of a trough 14b, is intended in all instances to be less than the width of the face 15 or 16 of the nut or bolthead 17 or 18. The arrangement, as shown particularly in FIG. 2, is such that the full effective crest-to-trough height of the wrench structure may be brought to bear upon the face of the nut or bolthead for maximum stability of the wrench in relation to the thickness of the sheet or strip metal of which it is formed. The crest-to-trough height *h* of the structural corrugations may be varied within limits, but should not exceed the

height of the faces 15 or 16 of the nuts or boltheads intended to be accommodated by the wrench. As a practical lower limit, the height  $h$  of the wrench probably should be at least twice and typically a larger multiple of the sheet or strip thickness.

In the wrench illustrated in FIGS. 1 and 2, the pitch dimension  $p$  is shown to be approximately equal to the width of the nut or bolt face. It will be understood, however, that the pitch may be considerably smaller than the face width, and that a particularly optimum arrangement from the standpoint of wrench stability may be a pitch of  $\frac{2}{3}$  or less of the face width, providing maximum crest-to-trough height effectiveness of the wrench in all positions on the nut or bolt face.

Typically, the pitch dimensions  $p$  of the corrugations 14 will be calculated with respect to a standard hex nut and bolt, which would automatically adapt the wrench for use on square nuts and boltheads because of the greater face width dimensions in the latter instance. On the other hand, the face height of square nuts and boltheads typically may be somewhat smaller than for hex nuts and bolts, so the corrugation height  $h$  may advantageously be calculated to accommodate the square fasteners, in which event they will automatically be suitable for the hex.

In the modification shown in FIGS. 3 and 4, the wrench body 20 is provided with a first set of corrugations 21, advantageously disposed at right angles to the axes of the respective wrench jaws 22, 23, and a second set of corrugations 24 disposed along the principal axis of the wrench handle 25. The corrugations 21 in the region of the wrench jaws are proportioned in accordance with the parameters mentioned with respect to the wrench of FIGS. 1 and 2, to impart improved grip and stability to the wrench jaws as well as to impart the improved rigidity conventionally derived from corrugated construction. The axial corrugations 24, along the wrench handle 25, are simply for the purpose of imparting increased strength to the handle, and the pitch and height dimensions of the corrugations need not be related to the geometry of the nuts and boltheads to be accommodated.

In any of its various forms, the tool of the invention incorporates corrugations of predetermined geometry running generally transverse of the axis of the jaw. This arrangement provides for significantly increased effective strength of a wrench or the like, as compared to a wrench of conventional, flat, stamped-out construction, particularly in regard to the stability of the wrench in its gripping of a nut or bolthead. Transversely disposed corrugations in the region of the wrench jaw, having a corrugation pitch less than the face width of the nut or bolthead, provide for an increase in the effective height of the wrench, as compared to a conventional stamped-out wrench, from the thickness of the metal stock to the height of the corrugation, which is advantageously a multiple of two or more times the stock thickness. The significantly improved gripping stability of the tool minimizes the distorting forces which otherwise are often exerted upon similar tools of stamped-out construction, which significantly increases the effective strength of the tool for its intended use. This improvement in effective strength is, of course, over and above the improved strength and rigidity which customarily results from the use of corrugated structure.

The new construction substantially extends the usefulness and commercial desirability of stamped-out wrenches, for example: first, because the improved effective strength of the wrench renders it suitable for a wider variety of applications than before, and, second, because it is possible to reduce the cost of such wrenches for existing applications through the utilization of lighter gages of metal stock to achieve equivalent effective strength.

It should be particularly understood that the specific forms of the invention herein illustrated and described are intended to be representative only, as certain changes

may be made therein without departing from the clear teachings of the disclosure. Accordingly, reference should be made to the following appended claims in determining the full scope of the invention.

1. In a gripping tool of stamped-out sheet metal construction, the improvement characterized by

- (a) at least the jaw areas of said tool having corrugations formed therein,
- (b) the corrugations being disposed at a large angle to the gripping faces of the jaws, and
- (c) said corrugations having a pitch not substantially exceeding the face width of a nut or other element of a size adapted to be gripped by said tool jaws.

2. A gripping tool according to claim 1, further characterized by

- (a) said gripping tool being a double open-end wrench and having an elongated handle portion and jaw areas at opposite ends of said handle portion,
- (b) said jaw areas having jaw axes defined by the gripping faces of the wrench jaws and disposed at a small angle relative to the principal axis of said handle,
- (c) said wrench being corrugated substantially uniformly throughout, and
- (d) said corrugations being disposed at an angle of not substantially less than  $90^\circ$  to said jaw axes and said handle axis.

3. A wrench according to claim 2, further characterized by

- (a) said elongated handle portion being provided with a covering of plastic material.

4. A gripping tool according to claim 1, further characterized by

- (a) said gripping tool being a double open-end wrench and having an elongated handle portion and jaw areas at opposite ends of said handle portion,
- (b) said jaw areas having jaw axes defined by the gripping faces of the wrench jaws and disposed at a small angle relative to the principal axis of said handle,

- (c) said wrench being corrugated in said jaw areas with corrugations disposed at an angle of not substantially less than  $90^\circ$  to said jaw axes, and
- (d) said handle portion being provided with strengthening corrugations.

5. In a wrench or like tool of stamped-out sheet metal construction, the improvement characterized by

- (a) at least the jaw areas of said tool having corrugations formed therein,
- (b) the corrugations being disposed at a large angle to the gripping faces of the tool jaws,
- (c) said corrugations having a pitch not substantially exceeding two-thirds of the face width of a hex nut of a size adapted to be gripped by said tool jaws, and
- (d) said corrugations having a height not substantially in excess of the face height of a nut of a size adapted to be gripped by said jaws.

6. A gripping tool according to claim 5, further characterized by

- (a) said corrugations being of a height not substantially less than twice the thickness of said sheet metal.

7. In a gripping tool of stamped-out sheet metal construction, the improvement characterized by

- (a) at least the jaw areas of said tool having corrugations formed therein, and
- (b) the corrugations being disposed at a large angle to the gripping faces of the jaws,
- (c) said corrugations having a pitch, in relation to the effective face width of objects to be gripped, such as to substantially increase the effective height of the gripping faces of the tool jaws in relation to the thickness of the sheet metal.

8. In a gripping tool, the improvement characterized by

5

- (a) at least the jaw areas of said tool having corrugations formed therein, and
- (b) the corrugations being disposed at a large angle to the gripping faces of the jaws,
- (c) said corrugations having a pitch, in relation to the effective face width of objects to be gripped, such as to substantially increase the effective height of the gripping faces of the tool jaws in relation to the thickness of the material of which the wrench is formed.

6

## References Cited by the Examiner

## UNITED STATES PATENTS

D. 105,338 7/1937 McNaught.  
 1,779,170 10/1930 Johnson ----- 7-17 X

## FOREIGN PATENTS

97,949 1/1940 Sweden.

WILLIAM FELDMAN, *Primary Examiner.*

M. MEHR, *Assistant Examiner.*