

(19) World Intellectual Property Organization
International Bureau



(43) International Publication Date
19 January 2012 (19.01.2012)

(10) International Publication Number
WO 2012/009478 A1

(51) International Patent Classification:
F03B 9/00 (2006.01)

Heights, MI 48127 (US). **BRATTEN, Keith** [US/US];
23900 Haggerty Road, Farmington Hills, MI 48335 (US).

(21) International Application Number:
PCT/US2011/043916

(74) Agent: **MURPHY, Kristin, L.**; Rader, Fishman &
Grauer PLLC, 39533 Woodward Avenue, Suite 140,
Bloomfield Hills, MI 48304 (US).

(22) International Filing Date:
13 July 2011 (13.07.2011)

(81) Designated States (unless otherwise indicated, for every
kind of national protection available): AE, AG, AL, AM,
AO, AT, AU, AZ, BA, BB, BG, BH, BR, BW, BY, BZ,
CA, CH, CL, CN, CO, CR, CU, CZ, DE, DK, DM, DO,
DZ, EC, EE, EG, ES, FI, GB, GD, GE, GH, GM, GT,
HN, HR, HU, ID, IL, IN, IS, JP, KE, KG, KM, KN, KP,
KR, KZ, LA, LC, LK, LR, LS, LT, LU, LY, MA, MD,
ME, MG, MK, MN, MW, MX, MY, MZ, NA, NG, NI,
NO, NZ, OM, PE, PG, PH, PL, PT, RO, RS, RU, SC, SD,
SE, SG, SK, SL, SM, ST, SV, SY, TH, TJ, TM, TN, TR,
TT, TZ, UA, UG, US, UZ, VC, VN, ZA, ZM, ZW.

(25) Filing Language: English

(26) Publication Language: English

(30) Priority Data:
61/363,943 13 July 2010 (13.07.2010) US

(71) Applicant (for all designated States except US): **NA-
TURE'S ENERGY BANC** [US/US]; 24442 West War-
ren, Dearborn Heights, MI 48127 (US).

(72) Inventors; and
(75) Inventors/Applicants (for US only): **BROOKS, Jeffrey**
[US/US]; 24442 West Warren, Dearborn Heights, MI
48127 (US). **JOHNSON, Gregory** [US/US]; 24442 West
Warren, Dearborn Heights, MI 48127 (US). **COURTER,
Douglas** [US/US]; 24442 West Warren, Dearborn

(84) Designated States (unless otherwise indicated, for every
kind of regional protection available): ARIPO (BW, GH,
GM, KE, LR, LS, MW, MZ, NA, SD, SL, SZ, TZ, UG,
ZM, ZW), Eurasian (AM, AZ, BY, KG, KZ, MD, RU, TJ,
TM), European (AL, AT, BE, BG, CH, CY, CZ, DE, DK,
EE, ES, FI, FR, GB, GR, HR, HU, IE, IS, IT, LT, LU,
LV, MC, MK, MT, NL, NO, PL, PT, RO, RS, SE, SI, SK,

[Continued on next page]

(54) Title: HYDRAULIC WIND POWER STORAGE AND ELECTRICAL ENERGY GENERATION SYSTEM

(57) Abstract: A wind power storage and electrical energy generation system is disclosed. The system includes at least one wind turbine; a hydraulic pump operatively connected to each wind turbine; a pressurized holding tank; a hydraulic motor; a power generator; and a non-pressurized return tank.

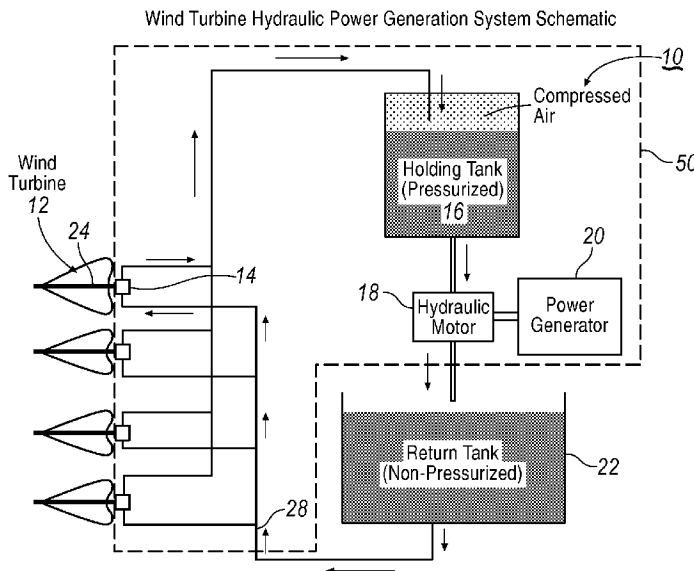

FIG. 1

WO 2012/009478 A1

SM, TR), OAPI (BF, BJ, CF, CG, CI, CM, GA, GN, GQ, GW, ML, MR, NE, SN, TD, TG). **Published:**

— with international search report (Art. 21(3))

HYDRAULIC WIND POWER STORAGE AND ELECTRICAL ENERGY GENERATION SYSTEM

CROSS REFERENCE TO RELATED APPLICATION

[0001] This application claims priority to U.S. Provisional Patent Application No.: 61/363,493 filed July 13, 2010, the disclosures of which are incorporated by reference in its entirety.

TECHNICAL FIELD

[0002] A system is disclosed to harness the kinetic energy of the wind by use of wind turbines attached to a closed loop hydraulic storage system.

BACKGROUND

[0003] Energy demands are increasing, while the world's oil and fossil fuels production capabilities are declining. Accordingly, attention is being increasingly drawn to renewable energy resources such as solar power and wind turbines. While wind turbines have been in use for some time, with the increasing interest in renewable energy, wind turbine generators are being built in increasingly large numbers and in larger power generation sizes.

[0004] However, a limitation of current wind turbine generators is that current technology limits the ability to harness, store and steadily transform wind energy into useable electric power. Indeed, the inherent variability of wind speeds can severely damage the performance of wind turbines that have a direct drive alternator system.

[0005] In some prior art systems, a wind turbine is connected to an alternator/generator through a speed increasing transmission. Because a wind turbine may turn up to about 60 rpm in a steady wind of 20 mph, but typical generators requires a constant input shaft speed of about 1200 to 1800 rpm, depending on the type of generator, to produce quality power. Accordingly, it has been known to provide variable speed generators. However, the power output of a variable speed generator must be conditioned before it can be fed into a power grid.

[0006] It is also known to use an open loop hydraulic system in place of mechanical transmissions. However, conventional hydraulic pumps require input speed of a minimum of

about 300 to 500 rpm to produce usable hydraulic pressure. Accordingly, open loop hydraulic systems require a mechanical speed increaser disposed between the wind turbine and the hydraulic pump, complicating the system and leading to increased likelihood of mechanical breakdown.

[0007] Therefore, there remains a need for a wind turbine generation system that is designed to harness the kinetic energy of the wind, store the energy and to release the stored energy at a steady rate.

BRIEF DESCRIPTION OF THE DRAWINGS

[0008] Some configurations of the storage and energy generation system will now be described, by way of example only and without disclaimer of other configurations, with reference to the accompanying drawings, in which:

[0009] FIG. 1 is a schematic of an exemplary wind turbine hydraulic power generation system;

[0010] FIG. 2 is a schematic of a hydraulic system control for use in a wind turbine hydraulic power generation system of FIG. 1; and

[0011] FIG. 3 is a schematic of an exemplary wind turbine integrated pole and tank design.

DETAILED DESCRIPTION

[0012] Referring now to the drawings, exemplary storage and energy generation systems are shown in detail. Although the drawings represent alternative configurations of storage and energy generation system, the drawings are not necessarily to scale and certain features may be exaggerated to provide a better illustration and explanation of a configuration. The configurations set forth herein are not intended to be exhaustive or to otherwise limit the device to the precise forms disclosed in the following detailed description.

[0013] FIG. 1 is a schematic of an exemplary wind turbine hydraulic power generation system 10. System 10 includes at least one wind turbine 12 that is operatively connected to a hydraulic pump 14. In one exemplary arrangement, a plurality of wind

turbines 12 are provided, with each wind turbine 12 being provided with a hydraulic pump 14.

[0014] Hydraulic pump 14 is operatively connected to a pressurized holding tank 16. A hydraulic motor 18 is operatively connected to the pressurized holding tank 16. A power generator 20 is connected to hydraulic motor 18. A non-pressurized return tank 22 is also included.

[0015] In one configuration, system 10 includes a plurality of wind turbines 12 that are mounted on shafts 24, and each shaft is connected to an individual hydraulic pump 14. As wind causes vanes 26 of wind turbines 12 to turn, this action causes shafts 24 to rotate. The shaft rotation turns hydraulic pumps 14 resulting in delivery of pressurized fluid to holding tank 16.

[0016] Pressurized holding tank 16 contains compressed air and hydraulic fluid. In one exemplary arrangement, pressurized holding tank utilizes water with a biodegradable glycol as a hydraulic fluid. In addition, system 10 may further comprise a UV light to control bacterial growth within tanks 16 and 22.

[0017] Pressurizing holding tank 16 is configured to release the collected pressure generated by hydraulic pumps 14 at a steady rate to hydraulic motor 18. Because the pressure is released from holding tank 16 at a steady state, variations of wind speed have little, to any, effect on power generation. Hydraulic motor 18, in turn, drives an electrical power generator 20. Power generator 20 provides an electrical output which can then be processed for connection to any suitable power grid. Unpressurized fluid is then returned to pumps 14 via suitable conduits 28 to complete a closed circuit.

[0018] Referring to FIG. 2, a pressurized portion of the fluid loop 50 in system 10 may be seen, including an exemplary arrangement of flow control logic. More specifically, to operate a 1 kW hydraulic motor 18, pumps 14 direct compressed air to pressurized holding tank 16 along a fluid line 52. In one exemplary arrangement, pumps 14 direct the compressed air along a common fluid line 52, as shown. There are two exit ports 54, 56 from pressurized holding tank 16. The exit ports 54, 56 are fluidly connected to a flow control regulator 58, which, in turn, is connected to motor 18.

[0019] Disposed within the flow paths of the exit ports are check valves 60. In the exemplary arrangement disclosed, check valves 60 are 100 psi pilot operated check valves designed to permit pressurized fluid to operate motor 18. However, to prevent a blow out, fluid loop 50 may also include 145 psi Pilot operated check valves 62. A 5 psi check valve 64 may also be provided to prevent reverse blow back in fluid loop 50.

[0020] System 10 advantageously requires low maintenance and allows storage of energy for selective and steady, controlled release of energy, regardless of wind speeds. Further, unlike systems that employ air compressors, system 10 is quiet.

[0021] An alternative exemplary arrangement of a storage and generation system 100 is shown in FIG. 3. Storage and generation system 100 is disposed in a stacked manner, with a pressurized holding tank 102 being disposed beneath a non pressurized return tank 104. In this configuration, tanks 102 and 104 may be concealed within a hollow tube or tower member.

[0022] Wind turbines 106 are arranged along a common axial shaft 108 and shaft is operatively connected to a hydraulic pump (not shown) which is fluidly connected to pressurized holding tank 102. Similar to the previously described embodiment, a hydraulic motor 110 receives pressurized fluid from pressurized holding tank 102 at a predetermined and controlled rate. Hydraulic motor 110 is operatively connected to an electrical power generator 112. Unpressurized fluid is then returned to non-pressurized return tank 144.

[0023] It will be appreciated that the devices and methods described herein have broad applications. The foregoing embodiments were chosen and described in order to illustrate principles of the methods and apparatuses as well as some practical applications. The preceding description enables others skilled in the art to utilize methods and apparatuses in various embodiments and with various modifications as are suited to the particular use contemplated. In accordance with the provisions of the patent statutes, the principles and modes of operation of this invention have been explained and illustrated in exemplary embodiments.

[0024] It is intended that the scope of the present methods and apparatuses be defined by the following claims. However, it must be understood that this invention may be practiced otherwise than is specifically explained and illustrated without departing from its spirit or

scope. It should be understood by those skilled in the art that various alternatives to the embodiments described herein may be employed in practicing the claims without departing from the spirit and scope as defined in the following claims. The scope of the invention should be determined, not with reference to the above description, but should instead be determined with reference to the appended claims, along with the full scope of equivalents to which such claims are entitled. It is anticipated and intended that future developments will occur in the arts discussed herein, and that the disclosed systems and methods will be incorporated into such future examples. Furthermore, all terms used in the claims are intended to be given their broadest reasonable constructions and their ordinary meanings as understood by those skilled in the art unless an explicit indication to the contrary is made herein. In particular, use of the singular articles such as “a,” “the,” “said,” etc. should be read to recite one or more of the indicated elements unless a claim recites an explicit limitation to the contrary. It is intended that the following claims define the scope of the invention and that the method and apparatus within the scope of these claims and their equivalents be covered thereby. In sum, it should be understood that the invention is capable of modification and variation and is limited only by the following claims.

CLAIMS

What is claimed is:

1. A wind power storage and electrical energy generation system, comprising:
at least one wind turbine;
a hydraulic pump operatively connected to each wind turbine;
a pressurized holding tank;
a hydraulic motor;
a power generator; and
a non-pressurized return tank.
2. The wind power storage and electrical energy generation system of claim 1, wherein a plurality of wind turbines are provided.
3. The wind power storage and electrical energy generation system of claim 2, wherein the system is a closed loop system.
4. The wind power storage and electrical energy generation system of claim 1, further comprising UV light operatively directed to the pressurized tank.
5. The wind power storage and electrical energy generation system of claim 1, wherein pressurized holding tank stores compressed air and fluid.
6. The wind power storage and electrical energy generation system of claim 1, wherein the system comprises a plurality of pumps and wind turbines, and wherein the pumps are fluidly connected along a common fluid line.
7. The wind power storage and electrical energy generation system of claim 6, wherein the fluid line has an output that is directly connected to the pressurized holding tank.

8. The wind power storage and electrical energy generation system of claim 1, further comprising an outlet from the pressurized holding tank, wherein the outlet is fluidly connected to the hydraulic motor.
9. The wind power storage and electrical energy generation system of claim 8, wherein a check valve is positioned between the outlet of the pressurized holding tank and the hydraulic motor so as to permit the system to provide a threshold pressure to the hydraulic motor.
10. The wind power storage and electrical energy generation system of claim 9, further comprising a flow control regulator positioned between the check valve and the hydraulic motor.
11. The wind power storage and electrical energy generation system of claim 1, wherein the power generator is connected to the hydraulic motor.
12. The wind power storage and electrical energy generation system of claim 1, wherein the non-pressurized return tank is fluidly connected to the hydraulic motor.
13. The wind power storage and electrical energy generation system of claim 1, wherein non-pressurized return tank and the pressurized tank are stacked on one another.
14. The wind power storage and electrical energy generation system, wherein a plurality of wind turbines are arranged along a common axial shaft.

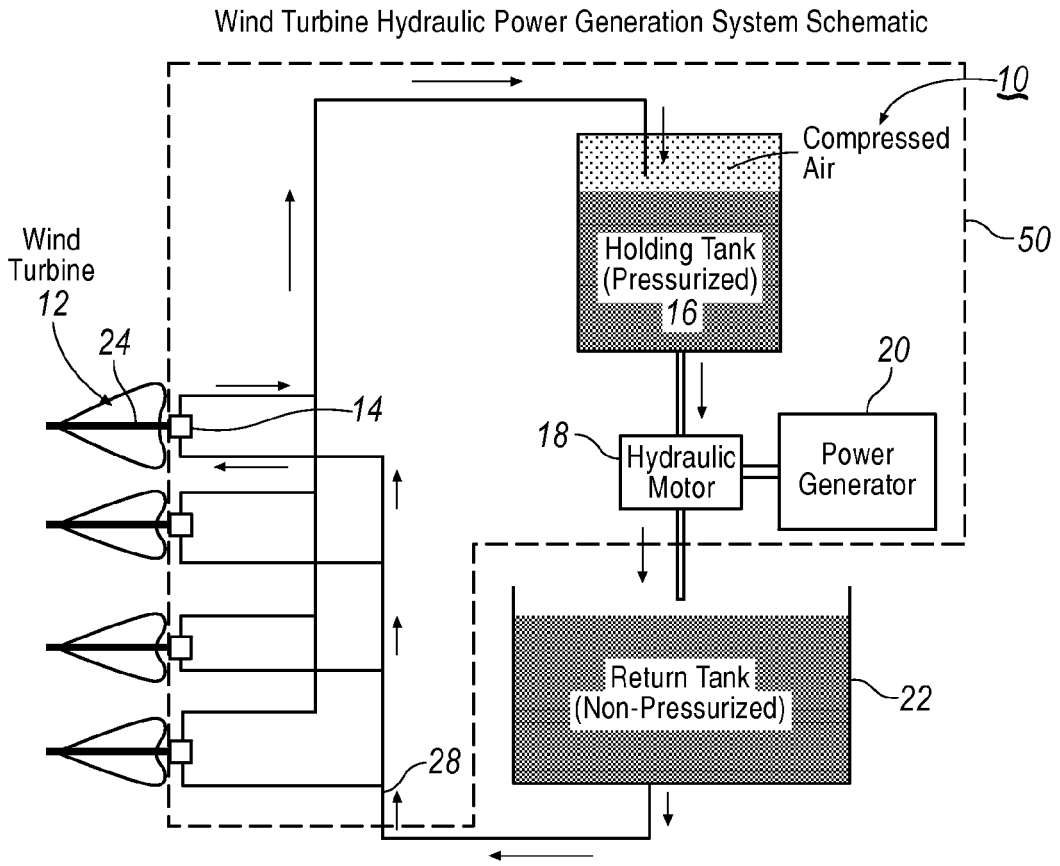

FIG. 1

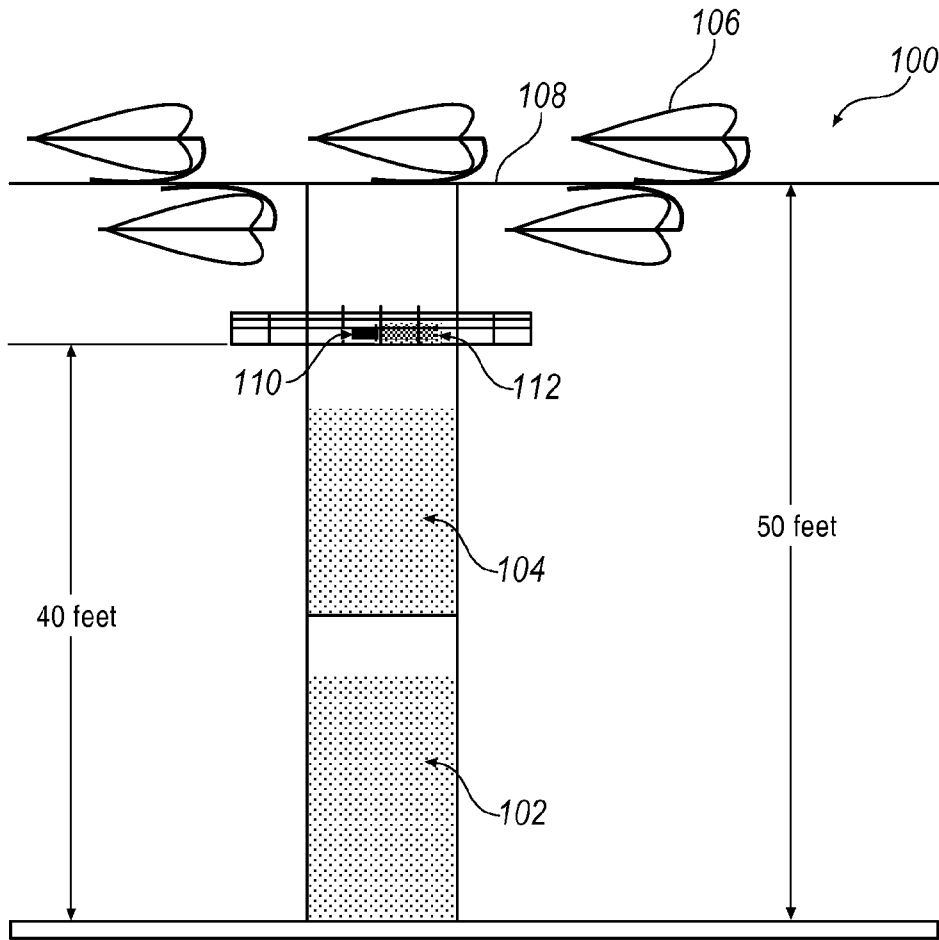

FIG. 3

INTERNATIONAL SEARCH REPORT

International application No.

PCT/US2011/043916

<p>A. CLASSIFICATION OF SUBJECT MATTER IPC(8) - F03B 9/00 (2011.01) USPC - 290/55 According to International Patent Classification (IPC) or to both national classification and IPC</p>																	
<p>B. FIELDS SEARCHED</p> <p>Minimum documentation searched (classification system followed by classification symbols) IPC(8) - F03B 9/00; F03D 7/00, 9/00 (2011.01) USPC - 290/43, 44, 55; 60/398</p> <p>Documentation searched other than minimum documentation to the extent that such documents are included in the fields searched</p> <p>Electronic data base consulted during the international search (name of data base and, where practicable, search terms used) PatBase, Google Patent Search, Google Scholar, IP.com</p>																	
<p>C. DOCUMENTS CONSIDERED TO BE RELEVANT</p> <table border="1"> <thead> <tr> <th>Category*</th> <th>Citation of document, with indication, where appropriate, of the relevant passages</th> <th>Relevant to claim No.</th> </tr> </thead> <tbody> <tr> <td>X -- Y</td> <td>US 2007/0138798 A1 (MCCLINTIC) 21 June 2007 (21.06.2007) entire document</td> <td>1-3, 5-13 ----- 4</td> </tr> <tr> <td>X</td> <td>US 2009/0107567 A1 (CRARY) 30 April 2009 (30.04.2009) entire document</td> <td>14</td> </tr> <tr> <td>Y</td> <td>US 2007/0187617 A1 (KONG et al) 16 August 2007 (16.08.2007) entire document</td> <td>4</td> </tr> <tr> <td>A</td> <td>US 2010/0104439 A1 (NOMAGUCHI et al) 29 April 2010 (29.04.2010) entire document</td> <td>1-14</td> </tr> </tbody> </table>			Category*	Citation of document, with indication, where appropriate, of the relevant passages	Relevant to claim No.	X -- Y	US 2007/0138798 A1 (MCCLINTIC) 21 June 2007 (21.06.2007) entire document	1-3, 5-13 ----- 4	X	US 2009/0107567 A1 (CRARY) 30 April 2009 (30.04.2009) entire document	14	Y	US 2007/0187617 A1 (KONG et al) 16 August 2007 (16.08.2007) entire document	4	A	US 2010/0104439 A1 (NOMAGUCHI et al) 29 April 2010 (29.04.2010) entire document	1-14
Category*	Citation of document, with indication, where appropriate, of the relevant passages	Relevant to claim No.															
X -- Y	US 2007/0138798 A1 (MCCLINTIC) 21 June 2007 (21.06.2007) entire document	1-3, 5-13 ----- 4															
X	US 2009/0107567 A1 (CRARY) 30 April 2009 (30.04.2009) entire document	14															
Y	US 2007/0187617 A1 (KONG et al) 16 August 2007 (16.08.2007) entire document	4															
A	US 2010/0104439 A1 (NOMAGUCHI et al) 29 April 2010 (29.04.2010) entire document	1-14															
<p><input type="checkbox"/> Further documents are listed in the continuation of Box C. <input type="checkbox"/></p>																	
<p>* Special categories of cited documents:</p> <table border="0"> <tr> <td> <p>"A" document defining the general state of the art which is not considered to be of particular relevance</p> <p>"E" earlier application or patent but published on or after the international filing date</p> <p>"L" document which may throw doubts on priority claim(s) or which is cited to establish the publication date of another citation or other special reason (as specified)</p> <p>"O" document referring to an oral disclosure, use, exhibition or other means</p> <p>"P" document published prior to the international filing date but later than the priority date claimed</p> </td> <td> <p>"T" later document published after the international filing date or priority date and not in conflict with the application but cited to understand the principle or theory underlying the invention</p> <p>"X" document of particular relevance; the claimed invention cannot be considered novel or cannot be considered to involve an inventive step when the document is taken alone</p> <p>"Y" document of particular relevance; the claimed invention cannot be considered to involve an inventive step when the document is combined with one or more other such documents, such combination being obvious to a person skilled in the art</p> <p>"&" document member of the same patent family</p> </td> </tr> </table>			<p>"A" document defining the general state of the art which is not considered to be of particular relevance</p> <p>"E" earlier application or patent but published on or after the international filing date</p> <p>"L" document which may throw doubts on priority claim(s) or which is cited to establish the publication date of another citation or other special reason (as specified)</p> <p>"O" document referring to an oral disclosure, use, exhibition or other means</p> <p>"P" document published prior to the international filing date but later than the priority date claimed</p>	<p>"T" later document published after the international filing date or priority date and not in conflict with the application but cited to understand the principle or theory underlying the invention</p> <p>"X" document of particular relevance; the claimed invention cannot be considered novel or cannot be considered to involve an inventive step when the document is taken alone</p> <p>"Y" document of particular relevance; the claimed invention cannot be considered to involve an inventive step when the document is combined with one or more other such documents, such combination being obvious to a person skilled in the art</p> <p>"&" document member of the same patent family</p>													
<p>"A" document defining the general state of the art which is not considered to be of particular relevance</p> <p>"E" earlier application or patent but published on or after the international filing date</p> <p>"L" document which may throw doubts on priority claim(s) or which is cited to establish the publication date of another citation or other special reason (as specified)</p> <p>"O" document referring to an oral disclosure, use, exhibition or other means</p> <p>"P" document published prior to the international filing date but later than the priority date claimed</p>	<p>"T" later document published after the international filing date or priority date and not in conflict with the application but cited to understand the principle or theory underlying the invention</p> <p>"X" document of particular relevance; the claimed invention cannot be considered novel or cannot be considered to involve an inventive step when the document is taken alone</p> <p>"Y" document of particular relevance; the claimed invention cannot be considered to involve an inventive step when the document is combined with one or more other such documents, such combination being obvious to a person skilled in the art</p> <p>"&" document member of the same patent family</p>																
<p>Date of the actual completion of the international search</p> <p>19 October 2011</p>		<p>Date of mailing of the international search report</p> <p>31 OCT 2011</p>															
<p>Name and mailing address of the ISA/US</p> <p>Mail Stop PCT, Attn: ISA/US, Commissioner for Patents P.O. Box 1450, Alexandria, Virginia 22313-1450 Facsimile No. . 571-273-3201</p>		<p>Authorized officer:</p> <p>Blaine R. Copenheaver</p> <p>PCT Helpdesk: 571-272-4300 PCT OSP: 571-272-7774</p>															