

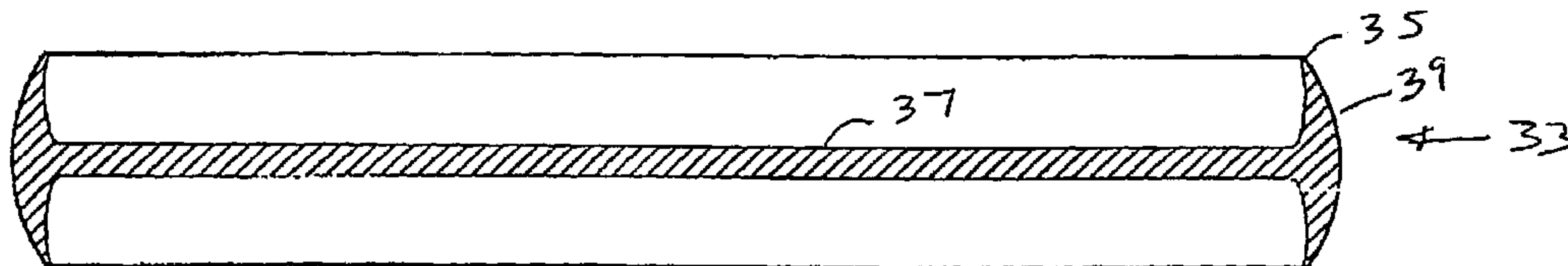

(86) Date de dépôt PCT/PCT Filing Date: 2000/12/21  
 (87) Date publication PCT/PCT Publication Date: 2001/07/12  
 (85) Entrée phase nationale/National Entry: 2002/07/02  
 (86) N° demande PCT/PCT Application No.: US 2000/035071  
 (87) N° publication PCT/PCT Publication No.: 2001/049385  
 (30) Priorité/Priority: 2000/01/03 (09/476,259) US

(51) Cl.Int.<sup>7</sup>/Int.Cl.<sup>7</sup> A63H 27/00  
 (71) Demandeur/Applicant:  
HUSET, LAWRENCE, US  
 (72) Inventeur/Inventor:  
HUSET, LAWRENCE, US  
 (74) Agent: BORDEN LADNER GERVAIS LLP

(54) Titre : JOUET A DISQUE CIRCULAIRE VOLANT  
 (54) Title: CIRCULAR FLYING DISK TOY



(57) Abrégé/Abstract:  
 A flying toy (33) including a cylindrical rim (35) having an outer surface (39) and a flat circular airfoil (37) located within the rim.

(12) INTERNATIONAL APPLICATION PUBLISHED UNDER THE PATENT COOPERATION TREATY (PCT)

(19) World Intellectual Property Organization  
International Bureau



(43) International Publication Date  
12 July 2001 (12.07.2001)

PCT

(10) International Publication Number  
**WO 01/49385 A1**

- |   |   |
|---|---|
| <p>(51) International Patent Classification<sup>7</sup>: <b>A63H 27/00</b></p> <p>(21) International Application Number: PCT/US00/35071</p> <p>(22) International Filing Date:<br/>21 December 2000 (21.12.2000)</p> <p>(25) Filing Language: English</p> <p>(26) Publication Language: English</p> <p>(30) Priority Data:<br/>09/476,259 3 January 2000 (03.01.2000) US</p> <p>(71) Applicant and<br/>(72) Inventor: <b>HUSET, Lawrence</b> [US/US]; 2208 State Avenue, Apt. B, Costa Mesa, CA 92627 (US).</p> | <p>(74) Agent: <b>GESS, Albin</b>; Price and Gess, 2100 S.E. Main Street, Suite 250, Irvine, CA 92614 (US).</p> <p>(81) Designated States (<i>national</i>): AU, CA, CN, ID, KR, MX, VN.</p> <p>(84) Designated States (<i>regional</i>): European patent (AT, BE, CH, CY, DE, DK, ES, FI, FR, GB, GR, IE, IT, LU, MC, NL, PT, SE, TR).</p> <p><b>Published:</b><br/>— <i>With international search report.</i></p> <p><i>For two-letter codes and other abbreviations, refer to the "Guidance Notes on Codes and Abbreviations" appearing at the beginning of each regular issue of the PCT Gazette.</i></p> |
|---|---|



(54) Title: CIRCULAR FLYING DISK TOY

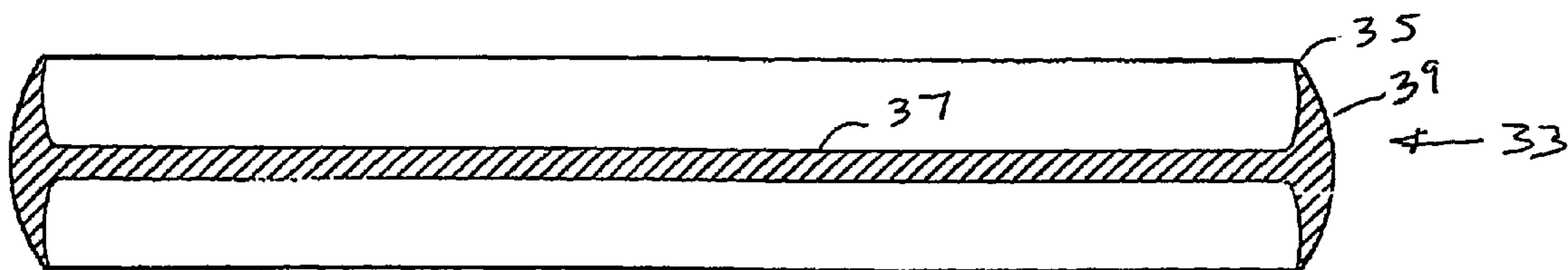

(57) Abstract: A flying toy (33) including a cylindrical rim (35) having an outer surface (39) and a flat circular airfoil (37) located within the rim.

**WO 01/49385 A1**

# CIRCULAR FLYING DISK TOY

## BACKGROUND OF THE INVENTION

### 1. Field of the Invention

5 The subject invention relates generally to toys and amusement devices and more particularly to an aerodynamic disk consisting of a circular center airfoil centered within a circular outer rim or ring.

### 2. Description of Related Art

10 Flying saucer devices, or so-called "frisbees," are known in the prior art. Such devices have been used as throwing implements or toys, typically in games of "catch." Such devices typically employ a central disk portion and a rim extending downwardly from and circumscribing the central disk, for example, as disclosed in U.S. Patent No. 3,359,678.

## SUMMARY OF THE INVENTION

15 The invention provides a flying toy including a cylindrical rim having a circular top edge running parallel to a circular bottom edge; and a flat circular central airfoil having a circular edge and a horizontal center line, the circular edge being attached to the inner circumference of the rim such that the centerline of the airfoil bisects the side surface of the rim. When thrown as a flying disk, the device provides increased  
20 gyroscopic effect and stability.

## BRIEF DESCRIPTION OF THE DRAWINGS

The just summarized invention will now be described in detail in conjunction with the drawings of which:

Fig. 1 is a perspective view of a first embodiment of the invention;

25 Fig. 2 is a sectional view taken at 2-2 of Fig. 1;

Fig. 3 is a perspective view of a second embodiment; and

Fig. 4 is a sectional view taken at 3-3 of Fig. 3.

-3-

### DETAILED DESCRIPTION

A prototype flying disc toy 11 according to a preferred embodiment is shown in Figs. 1 and 2. The center circular portion or airfoil 13 of this disc toy 11 is planar, constructed of foam board, and can vary in diameter, e.g., between 5" to 12" in diameter.

5 The outer ring 15 is cylindrical, comprised of posterboard, and may vary in height from 1" to 2" in correlation to the size of the center circular portion.

The outer ring 15, after it is cut to proper specifications, is positioned around the center airfoil 13 and attached at a 90-degree angle with a glue gun or other adhesive. The outer ring 15 is attached to the center airfoil 13 such that the center line 17 of the  
10 airfoil 13 bisects the side surface 20 so that equal portions 19 of the side surface 20 extend to each side of center line 17. For a 10" diameter disc, the side portions 19 may each be 3/4". As a result, the top and bottom of the device 11 are mirror images of one another.

After the outer ring 15 is attached to the center airfoil 13, silicone is applied over  
15 the perimeter of seams 21, or "equatorial line," where the outer ring 15 connects to the center airfoil 13. The Silicone is smoothed evenly around the entire circumference on both sides so that both sides, have a smoothed layer of silicone where the center airfoil 13 and outer ring 15 connect. This treatment increases the circumferential weight at the outer ring 15, increasing the gyroscopic effect tending to level the disc in flight.

20 The height of the ring 15 in relation to the diameter of the center horizontal airfoil 13 determines distance performance. Thus, for example, with a center horizontal airfoil diameter of 8", use of a vertical rim height 14 of 1 1/2" results in substantially more air resistance than a vertical rim height of 1 1/4". A ratio of diameter versus height of rim could vary from a ratio of 5:1 to a ratio of 8:1 without significantly effecting  
25 performance. Only the distance of flight is affected by this ratio. Greater height of the outer vertical rim results in more air caught between the airfoil and the outer rim, thus resulting in a more pronounced floating effect.

For production purposes, it is presently preferred to fabricate a flying disc 33 (Figs. 3 and 4) by a plastic injection molding process. The result is a molded plastic  
30 body including a flat center airfoil 37 bounded about its perimeter by a rim portion 35.

-4-

extending an equal distance on each side of the center airfoil 37. The rim portion 35 is at a 90-degree angle to the airfoil 37 for the entire circumference of center airfoil. The outer surface 39 of the rim portion 35 curves upwardly and downwardly from the center airfoil 37 enabling manual projection from either of the two identical sides.

5           The device 33 is thus shaped to provide a body having an aerodynamic airfoil profile, such that when it is flung through the air with a spinning motion, it appears to sail, or "float," through the air. The spinning motion imparted by a wrist-flick gyroscopically stabilizes the flight.

10           Devices such as those disclosed in Figs. 1-4 may be thrown by the user in a backhanded motion with one hand, keeping the arm parallel with the ground, and ending the throw with a snapping motion of the wrist. Variations of the angle of the arm at launch determine the angle of flight relative to altitude and direction.

15           The disclosed devices 11, 33 are easier to throw and catch due to their shape, levelness, and the effect of "floating" toward the receiving individual, rather than being "whipped" toward that individual. Children adapt to the device more quickly and easily, due to the steadiness of the flight and the ability to toss the device along a more level path and at a shorter range. Such devices can also be thrown in areas that previously did not lend themselves to this activity because such devices can be comfortably thrown at a closer range than those of the prior art, which is especially important in densely  
20           populated areas. Thus, a large span of playing field is unnecessary, and a device as disclosed can be comfortably used in an average-sized yard. It is also impossible for the device to be upside-down when thrown since both the top and bottom are identical.

25           Those skilled in the art will appreciate that various adaptations and modifications of the just-described preferred embodiments can be configured without departing from the scope and spirit of the invention. Therefore, it is to be understood that within the scope of the appended claims, the invention may be practiced other than as specifically described herein.

CLAIMSWhat Is Claimed Is:

- 1           1.       A flying toy comprising:  
2                   a cylindrical outer rim having an inner circumference and a circular top  
3 edge running parallel to a circular bottom edge; and  
4                   a flat circular central airfoil having an outer edge and a horizontal center  
5 line, said outer edge being attached to the inner circumference of said rim with said  
6 centerline intersecting said rim halfway between said top edge and said bottom edge.
- 1           2.       The toy of Claim 1 wherein said cylindrical rim has a curved outer side  
2 surface.
- 1           3.       The toy of Claim 1 further including weighting means for increasing the  
2 weight of the toy at the intersection of said airfoil and said rim.
- 1           4.       The toy of Claim 1 wherein said toy is formed as a single plastic part.
- 1           5.       The toy of Claim 3 wherein said toy is formed as a single plastic part.

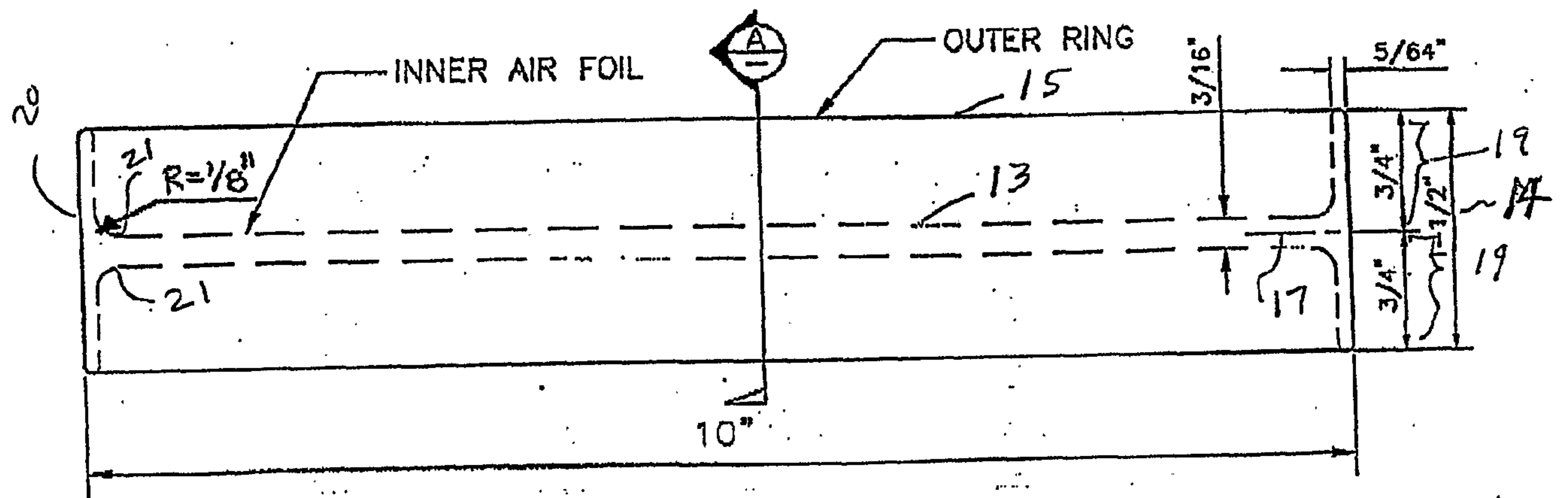
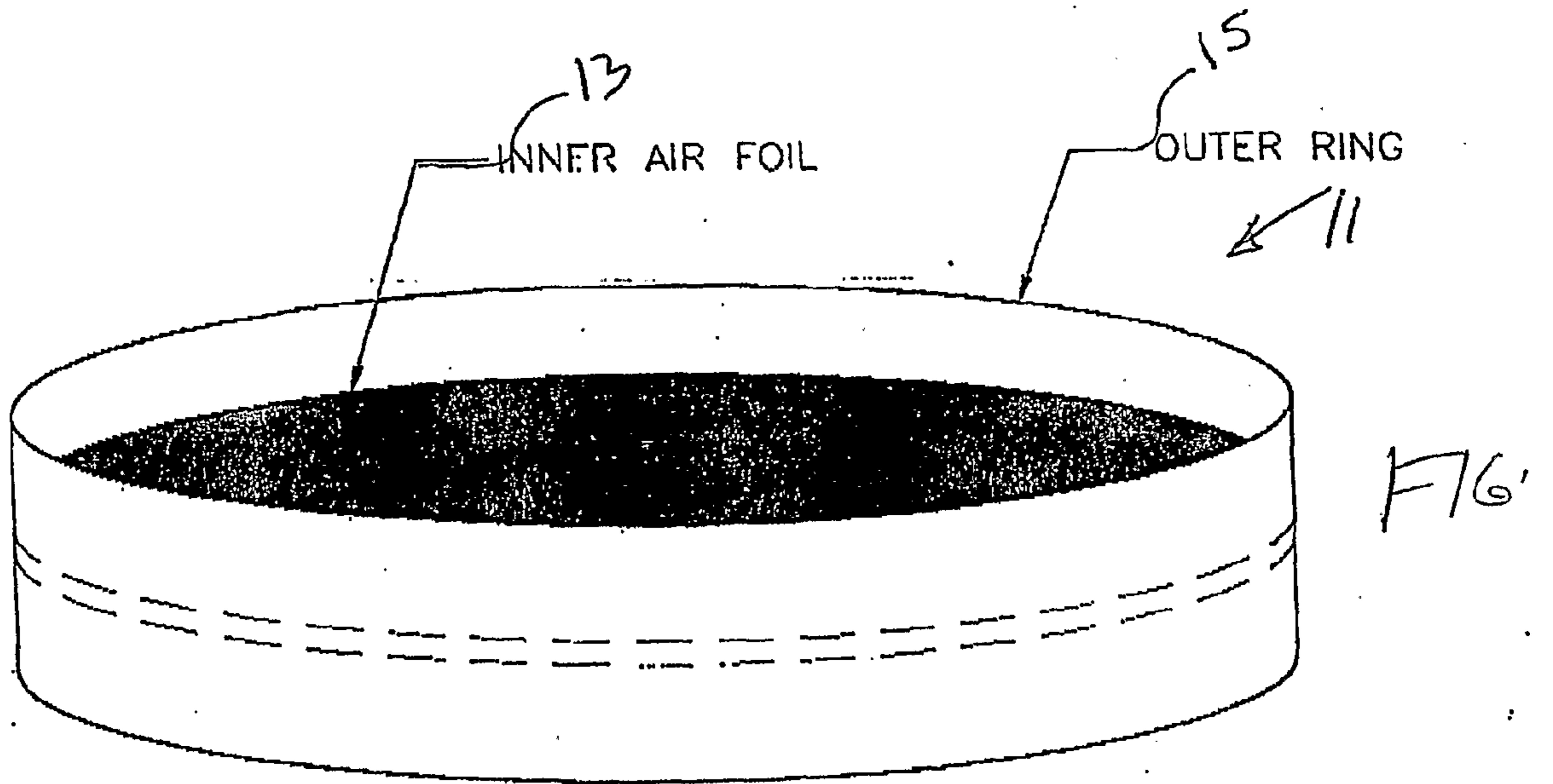

SIDE ELEVATION FIG. 2 SCALE: NONE

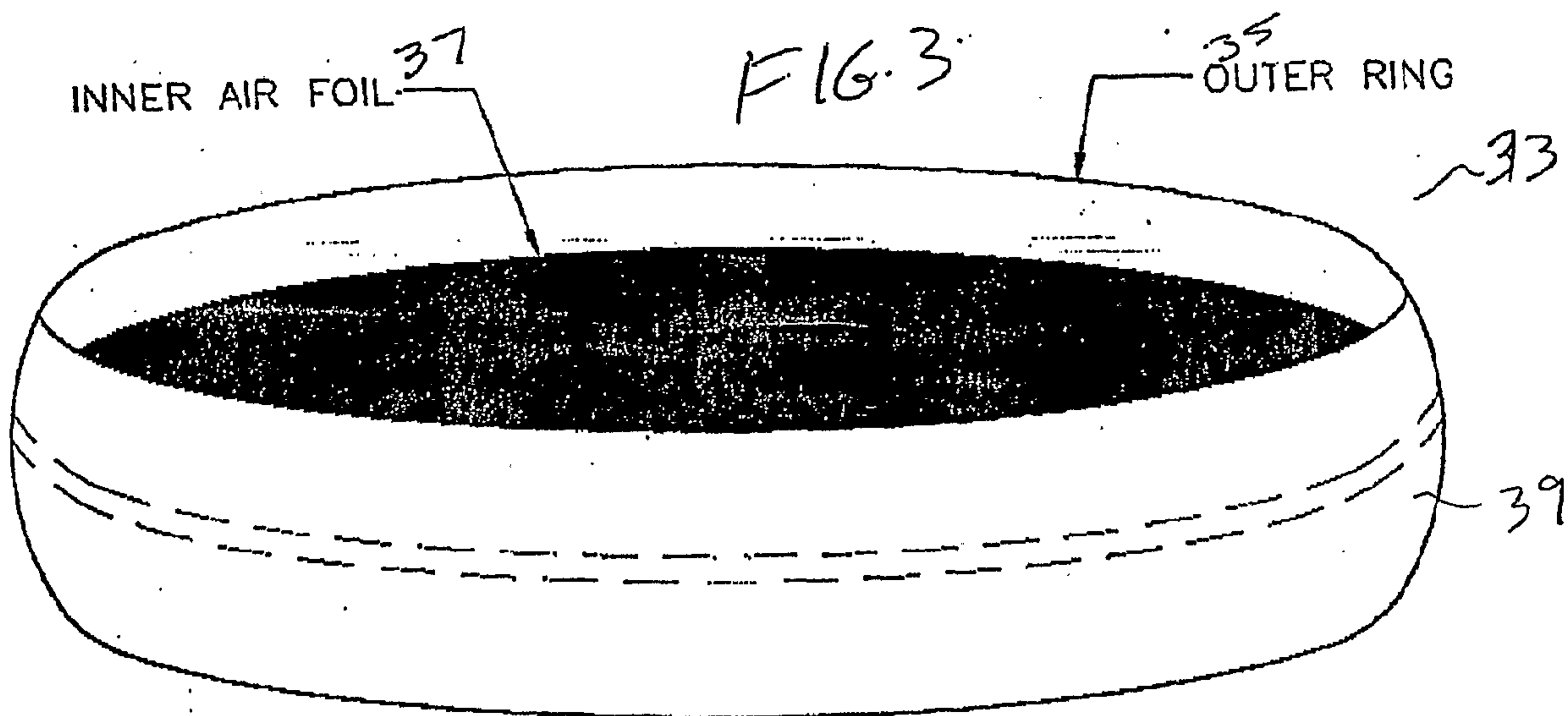

ISOMETRIC VIEW

SCALE: NONE

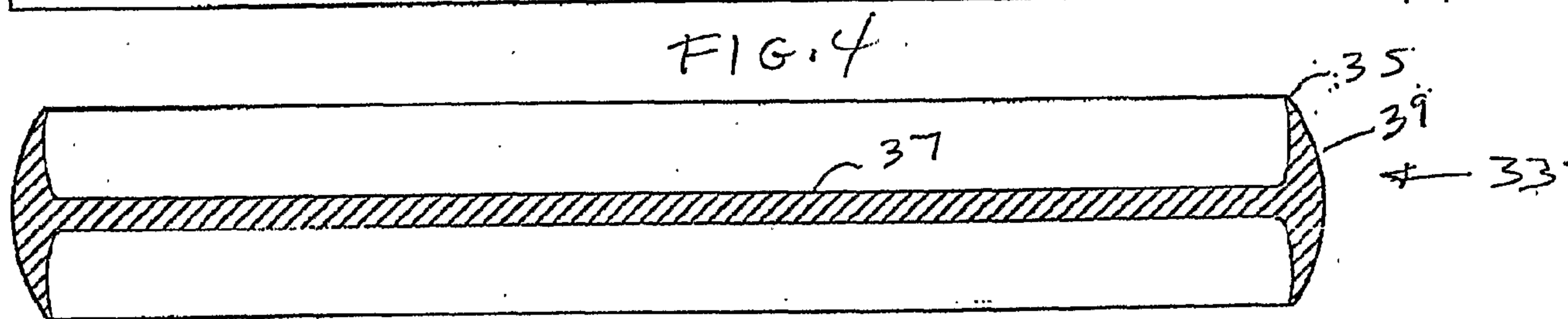

These are dimensions for plastic mold injection.

# FLIP 'N' FLYER

FEBRUARY 6, 2000

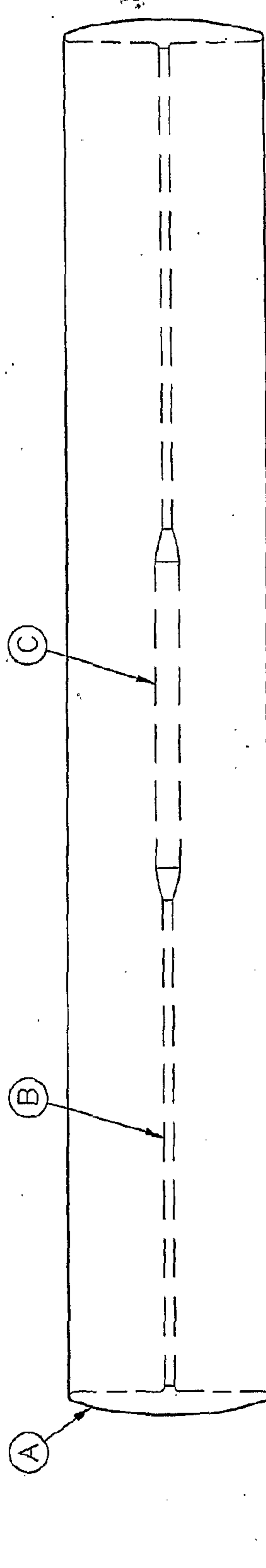
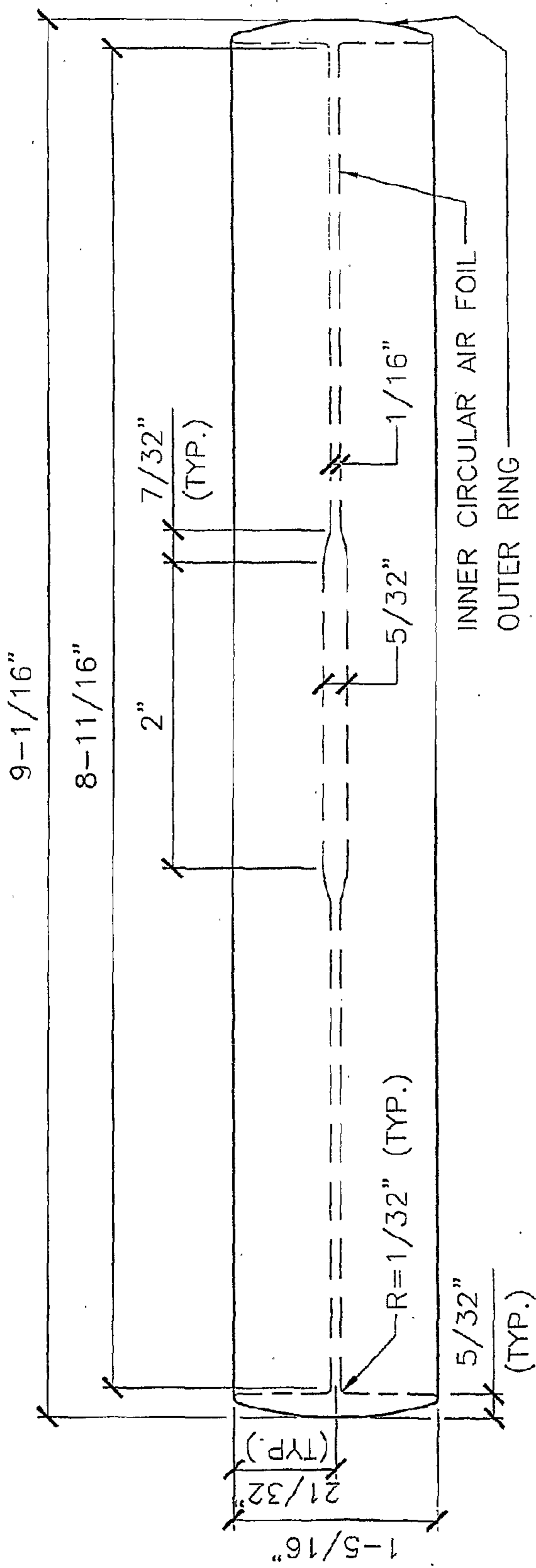

# LARRY HUSET

PATENT #09/476,259  
Pend.

# FLIP 'N' FLYER

FEBRUARY 11, 2000

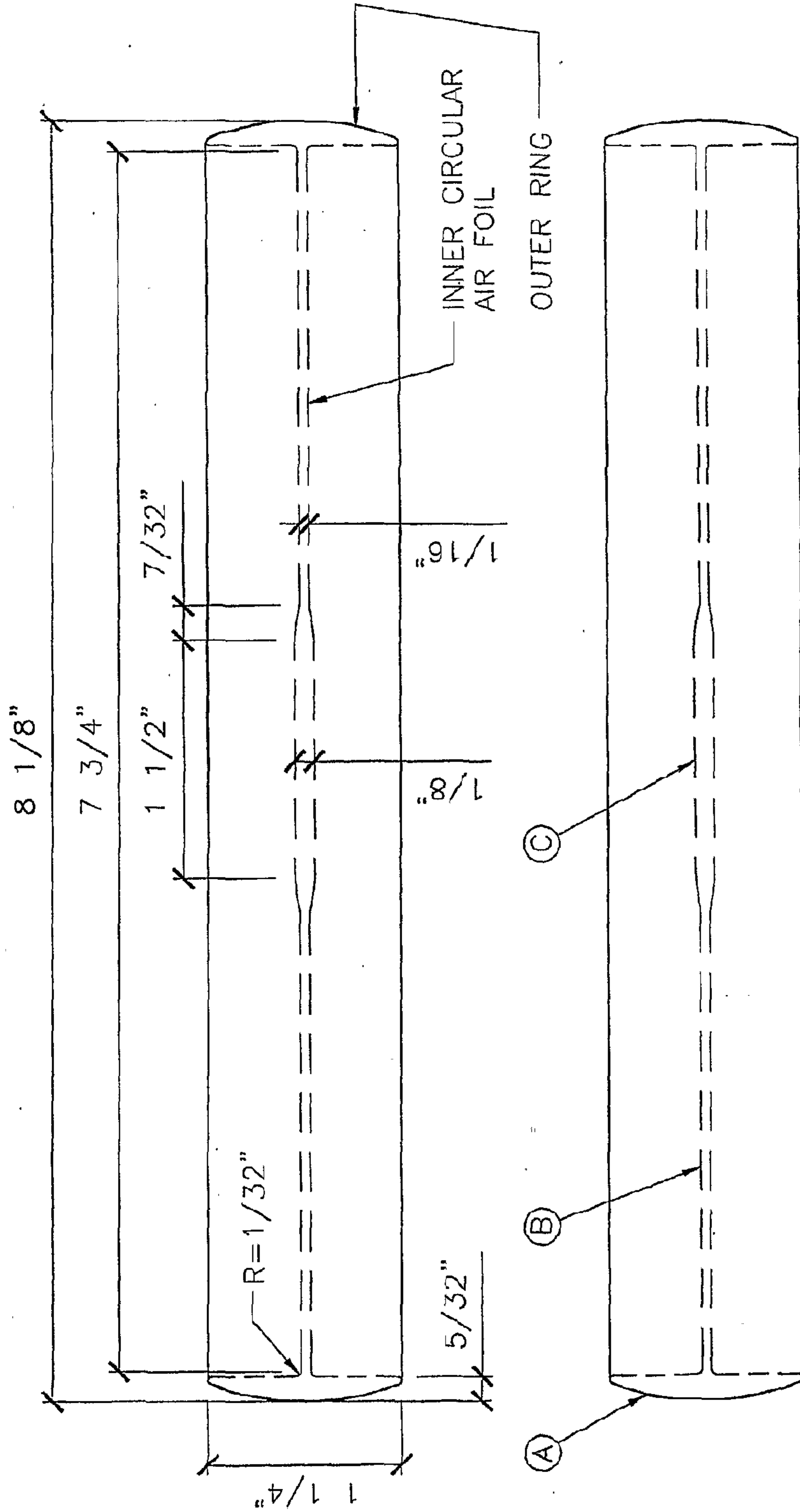

(A) = 66.8 cm<sup>3</sup>    (B) = 53.1 cm<sup>3</sup> - (1.81 cm<sup>3</sup>) = 51.29 cm<sup>3</sup>    (C) = 3.62 cm<sup>3</sup>

TOTAL = 121.71 cm<sup>3</sup> x .90g = 110g

FULL SCALE

## LARRY HUSET

PATENT #09/476,259  
*pend.*

