

J. W. WEST.
PROTECTOR FOR TUBE THREAD.
APPLICATION FILED MAR. 16, 1911.

1,001,718.

Patented Aug. 29, 1911.

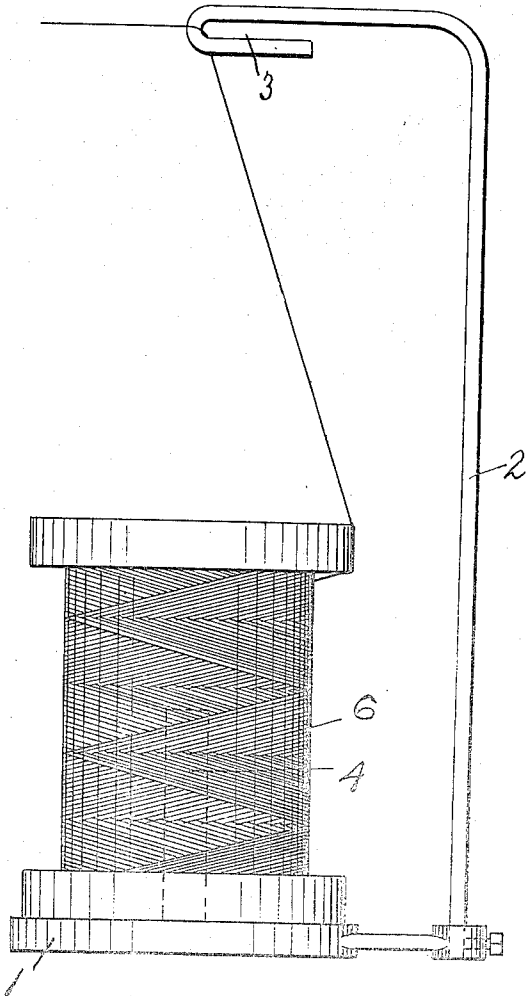
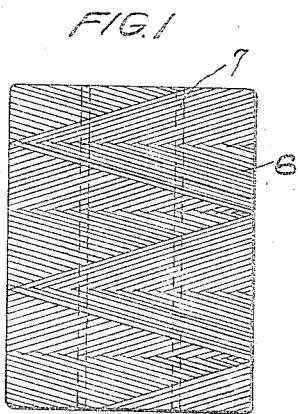
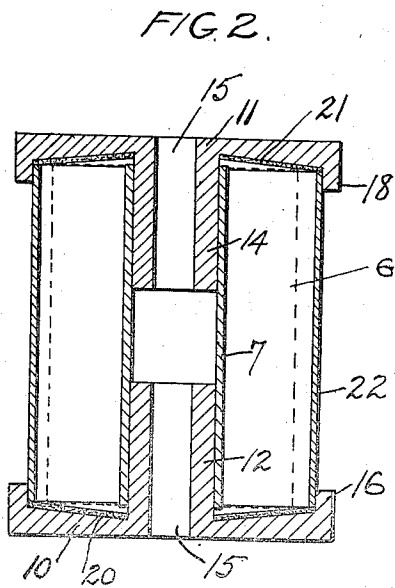

WITNESSES
James J. Carr
Rowena Balkus

INVENTOR
John W. West
by his Attorney
William H. Sperr

UNITED STATES PATENT OFFICE.

JOHN W. WEST, OF BRAINTREE, MASSACHUSETTS.

PROTECTOR FOR TUBE-THREAD.

1,001,718.

Specification of Letters Patent. Patented Aug. 29, 1911.

Application filed March 16, 1911. Serial No. 614,834.

To all whom it may concern:

Be it known that I, JOHN W. WEST, of Braintree, in the county of Norfolk and State of Massachusetts, have invented certain new and useful Improvements in Protectors for Tube-Thread, of which the following is a specification.

This invention relates to protectors for tube thread.

The cost of spools and the winding of the thread thereon is a considerable item in the total cost of a supply of thread for use on machines, especially upon the large sizes of spools. This expense has been greatly reduced by substituting paper tubes for the spools, but a large amount of thread is wasted by the breaking away of the corners of the cylindrical mass of thread on the tubes during handling, or by the catching of the thread about the spindle of the machine upon which the thread is being used, as it is drawn from the tube.

It is the purpose of this invention to protect the thread upon the tube during handling in shipment, and while being drawn off the tube, thus enabling the advantages of tube thread to be more fully realized.

Accordingly, one feature of the invention contemplates the provision of a device for protecting the thread and preventing it from catching or snarling at either end as it is drawn from the tube, while mounted on the spindle of a sewing machine.

A further feature of the invention contemplates the utilization of the foregoing protector to protect the tube of thread in shipping or handling, by providing an inclosing shell which surrounds the mass of thread and is held in place by the heads of the protector, thus preventing waste of thread.

With the above object in view, the invention consists in the protector for tube thread hereinafter described and particularly defined in the claims, the advantages of which will be obvious to those skilled in the art from the following description.

The invention will be clearly understood from an inspection of the accompanying drawing, in which—

Figure 1 is a view in elevation of a tube of thread as ordinarily sold and for which the protector is intended; Fig. 2 is a central vertical section of the protector complete ready for shipment, with the cylinder of thread in dotted lines; and Fig. 3 is a

view in elevation showing the tube of thread and protector in a standard for use in connection with sewing machines used in manufacturing establishments, the cylindrical shell of the protector being removed.

As illustrated in the drawing, 1 represents the base of the thread carrier, provided with a standard 2 having a guiding slot or eye 3, the base of the carrier being also provided with a vertical spindle 4, shown in dotted lines. This carrier is of well known construction, such as is employed in connection with sewing machines in manufacturing establishments. The cylindrical mass of thread 6 is wound upon a tube 7, constructed of wood pulp, or any other suitable material. The tube 7 wound with the mass of thread 6 is of the usual construction now on sale and in common use, and is ordinarily placed upon the vertical spindle 4, or on any spindle such as is often provided for the purpose in connection with small sewing machines. When so placed upon a sewing machine, the unwinding thread as it approaches either end of the cylindrical mass of thread frequently breaks away a corner or mass of the thread and becomes entangled about the spindle, thus causing a considerable waste of thread.

To protect the thread and prevent it from becoming tangled, I provide a pair of undercut heads having annular recesses on their adjacent faces to receive the ends of the mass of thread on the tube, said recesses being formed between central tubular stems and outer peripheral flanges over which the thread passes when drawn from the end of the mass, said tubular stems being axially movable in the tube and having their inner ends separated by a space, so that the heads can approach each other and be kept in contact with the ends of the mass of thread as it diminishes in size.

The preferred embodiment of the invention comprises a pair of heads 10 and 11, provided with integral stems 12 and 14, respectively, which are frictionally or otherwise detachably connected to or held in the interior of the tube 7. These stems are provided with central passages 15 for the reception of the spindle 4. The bottom of the head 10 is flat so that it can stand firmly upon a horizontal surface, and the periphery of the head is provided with an upwardly extending flange 16, which forms with the central stem 12 an annular recess to

60
65
70
75
80
85
90
95
100
105
110

receive the lower end of the mass of thread 6. The upper surface of the head 10 is inclined downward slightly from the flange 16 to the stem 12. The upper surface of the head 11 is also preferably flat, and the periphery of this head is provided with a depending flange 18, which forms with the central stem 14 an annular recess to receive the upper end of the mass of thread 6. The under surface of the head 11 is inclined upward slightly from the flange 18 to the stem 14. The inclined faces of the heads are lined with disks 20 and 21, of soft material, such as felt. These disks aid in keeping the mass of thread intact at its corners, as the bearing of the circular edge of the mass of thread on the felt lining aids in preserving or keeping the corners from breaking away. These linings also protect the ends of the mass of thread from being jammed or bruised when the protector ends are crowded down hard for shipment, and they also increase the frictional contact of the mass of thread with the heads of the protector, thus rendering them less liable to be untwisted from the tube 7 during handling or shipment.

In order to protect the thread during handling or shipment, I utilize the protector above described to hold a cylindrical shell or casing about the mass of thread by engagement with the flanges. As shown, a cylindrical shell 22, of wood pulp or any other suitable material, is held between the heads 10 and 11 by the peripheral flanges 16 and 18. With the parts as shown in Fig. 2, the thread is securely confined within the protector and protected against injury by rough handling, thereby obviating the necessity of a separate box for shipment.

When it is desired to use the thread, one of the heads 10, 11 is removed by withdrawal of its stem from the tube 7, and then the cylindrical shell 22 is removed. The head is then replaced upon the protector, or, under some circumstances the upper head need not be replaced. The protector with its thread is then placed in a vertical position upon the spindle 4. When the thread is being drawn off and reaches an end of the mass of thread, as illustrated in Fig. 3, the thread is guided away by the peripheral flange on the corresponding head so that it will not catch at the end of the mass of thread and cause it to fall away thus wasting material. The flanges deflect the thread below the plane of the end of the mass of thread 6 at the upper end, or above the plane of the end at the lower end. At whichever end of the tube of thread the thread is being drawn off, one of the flanges 16, 18 will guide it and prevent its breaking away in masses from the body of the thread, the lower head as well as the upper head being equally effective when the thread is drawn

off in a horizontal line, as would be the case if the device were being used with an ordinary domestic sewing machine.

By reference to Fig. 2 it will be seen that the outer corners of the mass of thread 6 are in contact with the soft material, or felt, in the annular recesses. This felt prevents the thread from creeping between the protector heads and the ends of the mass of thread, thereby keeping the thread from snarling about the spindle. As the diameter of the mass of thread diminishes, its corners are kept in contact with the felt by the axial movement of the protector heads, or, if only the lower head is used, by the downward movement of the mass of thread. This may be accomplished from time to time manually by the operator, or the fit between the stems 12 and 14 and the interior of the tube 7 may be made loose enough to allow the mass to lower itself by gravity.

While I have illustrated and described a preferred embodiment of the invention, I am aware that many modifications can be made therein by any person skilled in the art without departing from the scope of the invention as expressed in the claims. Therefore I do not wish to be limited to all the details of construction shown and described, but

What I claim is:—

1. A protector for tube thread, comprising a head having an annular recess adapted to receive one end of the mass of thread on the tube and to provide a peripheral flange over which the thread passes when drawn from the end of the mass, the bottom of said recess being covered with yielding material for engagement with the end of the mass of thread to prevent the thread from passing between the head and the end of the mass.

2. A protector for tube thread, consisting of a pair of undercut heads having central tubular stems adapted for detachable engagement with the opposite ends of the tube on which the thread is wound, the combined length of said stems being less than the length of the tube, whereby axial movement of the heads is permitted in a direction toward each other in order that they may engage the ends of the mass of thread on the tube as the thread is drawn off and the mass consequently diminished in size.

3. A protector for tube thread, consisting of a pair of heads having undercut annular recesses on their adjacent faces to receive the ends of the mass of thread on the tube and having central tubular stems to detachably engage the opposite ends of the tube said heads being axially movable in a direction toward each other and having the bottoms of their annular recesses covered with yielding material, whereby yielding engagement with the ends of the mass of thread

may be maintained as the thread is drawn off and the mass consequently diminished in size.

4. A protector for tube thread, consisting of a pair of heads having annular recesses on their adjacent faces to receive the ends of the mass of thread on the tube and to provide a peripheral flange over which the thread passes when drawn from the end of the mass, and central tubular stems on said heads adapted for slidable frictional engagement with the opposite ends of said tube.

5. A protector for tube thread, consisting of a pair of heads having annular recesses on their adjacent faces to receive the ends of the mass of thread on the tube and to provide a peripheral flange over which the thread passes when drawn from the end of the mass, central tubular stems on said heads detachably engaging the opposite ends of the tube, and a cylindrical shell adapted to inclose the mass of thread, its

opposite ends being held in engagement with said flanges.

6. A protector for tube thread, consisting of a pair of heads having annular recesses on their adjacent faces to receive the ends of the mass of thread on the tube and to provide a peripheral flange over which the thread passes when drawn from the end of the mass, central tubular stems on said heads adapted for slidable frictional engagement with the opposite ends of said tube, and a cylindrical shell adapted to inclose the mass of thread, its opposite ends being extended inside of and in frictional engagement with said flanges.

In testimony whereof I have affixed my signature, in presence of two witnesses.

JOHN W. WEST.

Witnesses:

ALBERT B. FOPIANO,
WILLIAM J. SPERL.