

(No Model.)

4 Sheets—Sheet 1.

B. H. SPECKBAUCH.
PRINTING PRESS.

No. 435,774.

Patented Sept. 2, 1890.

Fig. 1.

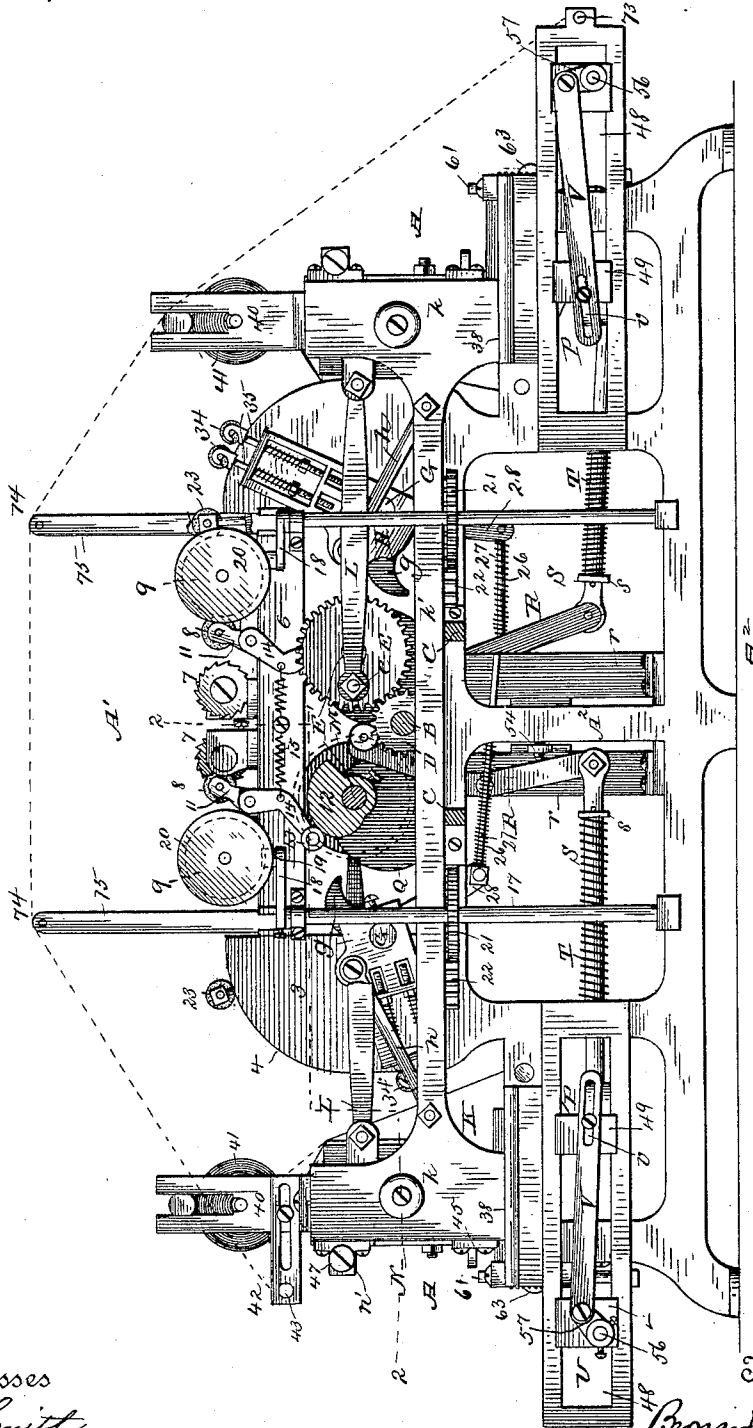

Witnesses
E. D. Smith
J. S. Barker

Inventor:
Bernard H. Speckbauch
By his Attorney
Marcellus Bailey

B. H. SPECKBAUCH.
PRINTING PRESS.

No. 435,774.

Patented Sept. 2, 1890.

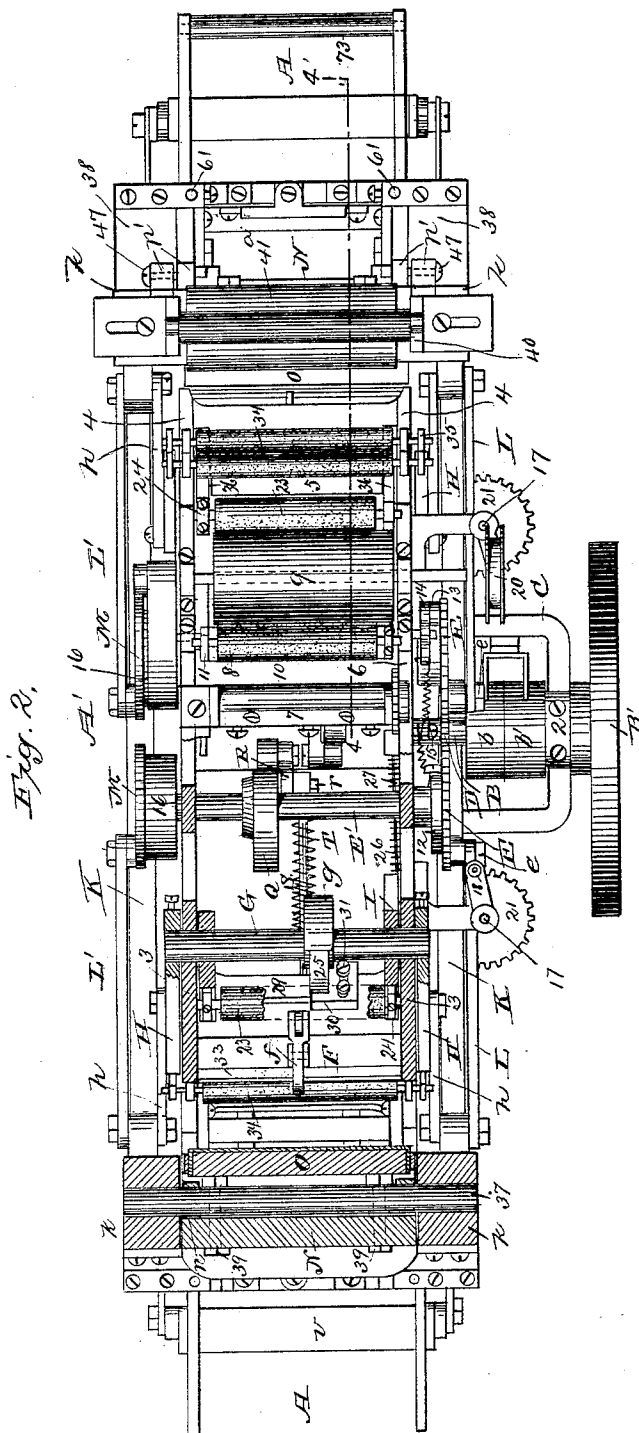

Witnesses
E. D. Smith
J. S. Barker

Inventor
Bernard H. Speckbauch
 By *His Attorney*
Maxwell Bailey

B. H. SPECKBAUCH. PRINTING PRESS.

No. 435,774.

Patented Sept. 2, 1890.

Fig. 2.

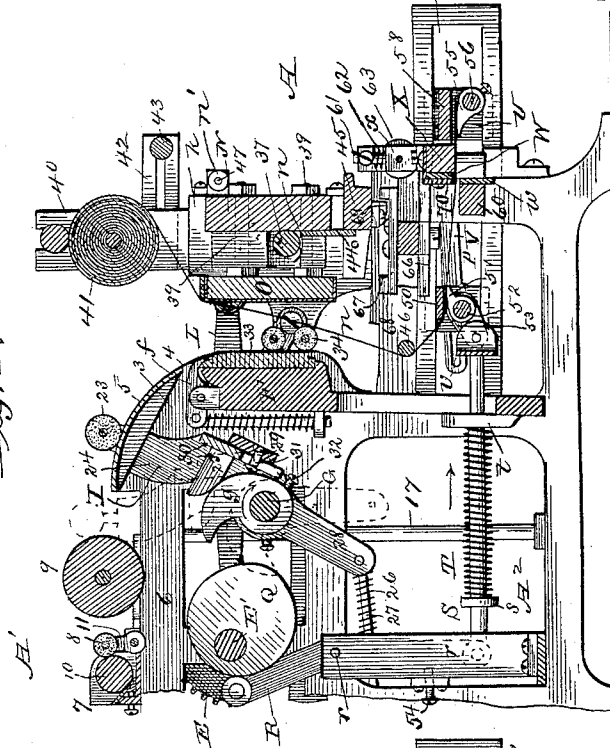
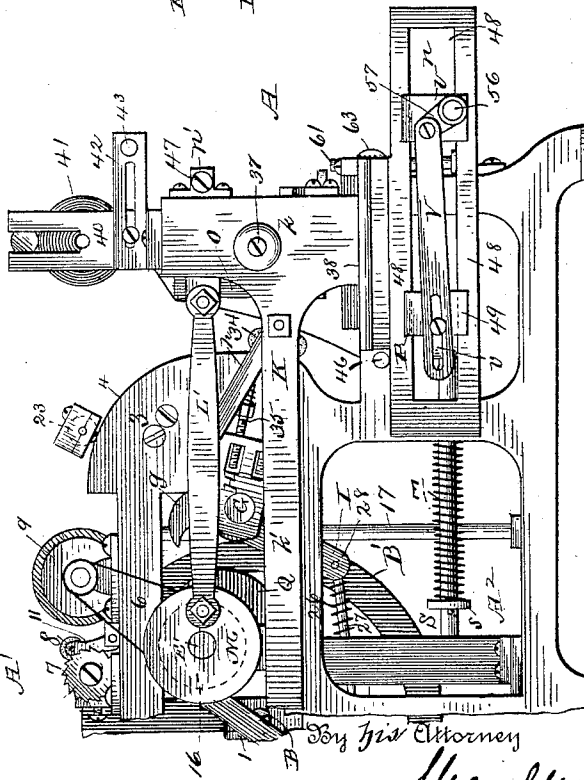

Fig. 3.



Witnesses
E. D. Smith
J. S. Barker.

Inventor
Bernard H. Speckbauch
 By his Attorney
Marcellus Wiley

B. H. SPECKBAUCH.
PRINTING PRESS.

No. 435,774.

Patented Sept. 2, 1890.

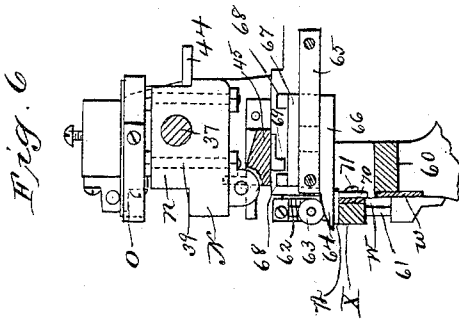

Fig. 6

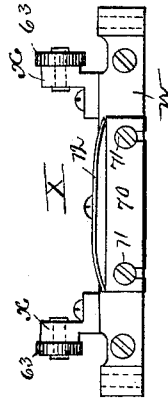

Fig. 7

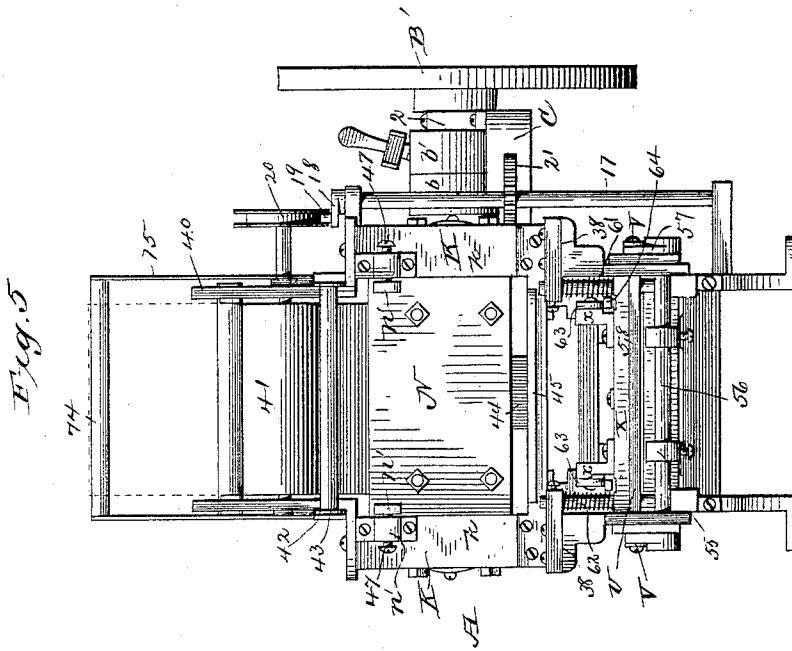

Fig. 5

Witnesses
E. D. Smith
J. S. Barker

Inventor
Bernard H. Speckbauch
 By his Attorney
Marcellus Bailey

UNITED STATES PATENT OFFICE.

BERNARD H. SPECKBAUCH, OF NEWPORT, KENTUCKY.

PRINTING-PRESS.

SPECIFICATION forming part of Letters Patent No. 435,774, dated September 2, 1890.

Application filed July 18, 1889. Serial No. 317,903. (No model.)

To all whom it may concern:

Be it known that I, BERNARD H. SPECKBAUCH, of Newport, in the county of Campbell, State of Kentucky, have invented certain new and useful Improvements in Printing-Presses, of which the following is a specification.

My invention has for its object to construct a platen printing-press which shall have greater capacity and capabilities than the presses of that character now in vogue; and it is embodied in a duplex machine carrying two forms, opposite to which work two platens, and provided with duplicate inking devices and driving mechanisms, the machine being adapted to print at the same time the same or different jobs from the two forms, or to print upon opposite sides of the same sheet, the paper being taken from a roll or rolls and automatically fed and cut into sheets.

The features in which my invention consists will be developed in the course of the following description, and will be more particularly pointed out in the claims.

The machine which is the embodiment of my invention is particularly adapted to job-work, and while it is duplex in its construction it will be understood that many of its features are adapted for use in single machines.

In order that my invention may be understood, I have shown it in the accompanying drawings, which are illustrative in their nature, some of the parts being out of proportion.

Referring to such drawings, Figure 1 is a front side view of a duplex machine embodying my invention, parts being broken away. Fig. 2 is a top plan view, one-half of the machine being in horizontal section on the line 2, Fig. 1. Fig. 3 is a rear side view of one-half of the machine. Fig. 4 is a vertical section on the line 4 4, Fig. 2. Fig. 5 is an end view. Fig. 6 is a vertical section of a portion of one end of the machine, showing the platen turned over for adjustment. Fig. 7 is a detail view of the knife.

The main frame-work of the machine, which is stationarily supported and upon which are mounted the various operative parts, is formed to have a horizontally-extending and comparatively low portion at each end, upon which

are supported the reciprocating sliding frame which carries the platens and the paper feeding and cutting devices, and these portions I have indicated, generally, by the letter A. 55

Between the end portions of the frame is an elevated portion, (represented by A') in and upon which are mounted and supported the chases carrying the forms, the inking devices, and most of the shafts and operating connections for imparting motion to the various parts of the apparatus, while below the portion A' the frame-work (here represented by A²) supports certain of the connecting parts of the apparatus. 60 65

B is the main power-shaft, provided with fast and loose pulleys *b b'*, and, if desirable, with a hand-wheel B', and journaled at its inner end in a bearing 1, located centrally in the upper central portion A' of the frame, and at its outer end in a bearing 2, supported on a bracket C, projecting laterally from the main frame. The power to drive the various moving parts of the machine is taken from this single shaft, which is provided with a gear-pinion D, with which mesh two large gear-wheels E E, arranged upon opposite sides of the pinion D and mounted upon transverse shafts E', supported in the upper central portion of the frame-work. 70 75 80

Since the construction of the frame-work and the arrangement and disposition of the operative parts are duplicated upon the opposite sides of the central shaft B, it will be necessary in the main to describe but one end of the machine. The beds F, in which the chases are supported, are at the ends of the upper central portion A' of the frame-work, which at these points has expanded side plates 3, the edges 4 of which form the tracks upon which run the inking-rollers for the form. The bed F is arranged between the lower straight and preferably vertical portions of the track 4, while between the upper curved portions thereof is placed an ink-distributing plate 5. 85 90 95

The chase may be locked in the bed in any preferred manner, a spring-catch device *f* being shown.

The ink fountain or fountains 7, from which the ink is taken for the forms at the opposite ends of the machine, are located centrally upon 100

and preferably above the top bars of the upper central portion A' of the frame and may be of any usual or preferred construction. From the fountain the ink is taken by a roller 8, mounted in a swinging frame, and delivered to a larger roller 9, which has a reciprocating motion in a direction parallel with its axis imparted to it, in order better to break up and spread the ink. The roller 8, which is reciprocated so as to be alternately brought into contact with the roller 10 of the fountain and the large ink-roller 9, is mounted so as to be free to turn with whichever roller it is brought into contact in the arms 11 of rocking frames mounted upon the opposite bars 6 of the frame-work. One of these rocking frames, preferably the one on the front side of the machine, is provided with an arm 14, carrying at its end an anti-friction roller 13, which rides upon a cam 12 on the shaft E', the end of the arm 14 being constantly drawn toward the cam by a spring 15. The cam 12 may be, and preferably is, formed on or secured to the rear face of the wheel E. The roller 9 has imparted to it a rotary motion, its shaft being belted to a pulley 16 on the shaft E', and is preferably also reciprocated in the direction of its axis by a rock-shaft 17, which carries at its upper end an arm 18, provided with a roller or block 19, seated in a groove in a wheel 20 at the end of the shaft of the roller 9. The shaft may receive its rocking motion in any preferred or convenient manner. I have shown it provided with a gear-wheel 21 meshing with a rack 22 on the reciprocating frame carrying the platens. The ink is taken from the large roller 9 and delivered to the spreading-plate 5 by a roller 23, mounted so as to turn freely in the upper end of the arms 24 of a swinging frame I, supported loosely upon a rock-shaft G, mounted in the main frame-work. This shaft has the frames or plates H, secured to its ends, from which plates it receives its motion, they being connected with the reciprocating frame by links *h*, so as to be rocked thereby.

g is a tappet or wiper adjustably supported upon the shaft G, opposite to which is mounted a contact-piece 25 on a cross-plate 29 of the frame I. The frame I is under the constant influence of a yielding force which tends to rock it so as to bring the roller 23 into contact with the roller 9, and this force I obtain from a spring 26, mounted upon a sliding rod 27, and compressed between some stationary portion of the frame of the machine and an arm 28 of the frame I, although I might obtain it by other means which will readily suggest themselves to those skilled in the art. As the shaft G is rocked in the direction of the arrow, Fig. 4, the tappet *g* is brought into contact with the piece 25 and causes the frame I to rock therewith, carrying the inking-roller 23 over the spreading-plate 5, as shown in full lines, and causing the spring 26 to be compressed. When the shaft is rocked in the opposite direction, the frame I follows the

tappet, under the influence of the compressed spring, until the roller 23 is brought against the roller 9, whereby it is stopped, while the tappet may continue its movement further and independent of the frame, as indicated in dotted lines, Fig. 4. It is desirable to be able to change the point in the oscillation of the shaft G at which the tappet shall make contact with the piece 25 and begin to move the frame I, in order that the extent to which the roller 23 shall be passed over the plate, and also the relative duration of its engagement with the roller 9 may be regulated. This adjustment may be secured by making the tappet *g* adjustable around its shaft and providing it with a set-screw 32, or by mounting the contact-piece 25 upon a slotted plate 30, adjustably secured to the cross-bar 29 of the frame I by the set-screws 31, both means being illustrated in the drawings. The ink is taken from the spreading-plate 5 to the form 33 by the rollers 34, which are mounted in the outer ends of the spring-rods 35, which are held in and take their motion from the frames or plates H. The ends of the rollers 34, or wheels mounted on the shafts thereof, run upon the tracks 4 on the side plates 3 of the form-bed, the rods or other supports for the rollers being mounted upon the outer sides of the plates 3. The supporting-arms 24 for the ink-roller 23 are mounted inside of the plates 3, so that they do not interfere in their movements with the rollers 34 or their supporting mechanism, and the plate 5 is slotted near its edges, as at 36 36, to permit the forward movement of the arms as they carry the roller over the plate.

Having thus described the inking devices, I will now describe the platens and the mechanism whereby they are moved to carry the paper against the forms after they have been inked.

In a duplex machine of the character which I have shown the forms are supported at or near the opposite ends of the stationary frame-work, and the platens are moved toward and from them, preferably with an alternate motion—that is, one platen approaches its opposing form as the other platen recedes. These motions may be secured in different ways and by various mechanisms, that shown in the drawings being the one preferred. It consists, in general terms, of a rectangular frame supporting at its opposite ends the platens and having a rectilinear sliding motion on the stationary frame-work of the machine to carry the platens to and from the forms. This platen-carrying frame is composed of two plates K, having expanded end portions *k* by the narrow bar portions *k'*. The opposite expanded portions *k* of the frame-pieces K are connected by cross-bars 37, which form pivotal supports upon which the platens are hung between the plates *k*.

38 38 are ways on the end portions A of the main frame-work upon which the platen-frame slides, the bearing-surfaces which ride

upon these ways being located on the end parts *k* of the platen-frame directly below the platens, thus supporting the frame directly beneath the only portions thereof which carry any considerable amount of weight, thereby permitting the connecting-bars *k'* to be made quite light. The platen-frame is driven from the shafts *E' E'*, the wheels *E* being provided with the wrist-pins *e*, which are connected by the pitmen *L L* with lugs upon the platen-frame. The shafts *E'* are provided at their rear ends with crank or wrist wheels *M*, each connected by a pitman *L'* with the platen-frame. I prefer to employ these four connections between the shafts *E'* and the platen-frame, as thereby a more steady motion is imparted to the latter and a better distribution of power is effected; but it will be understood that a single driving connection between the platen-frame and some moving part of the apparatus would be operative.

40 40 are the standards for receiving the rolls of paper 41, supported adjustably upon the upper sides of the end portions *k* of the platen-frame above the platens, and 42 are adjustable outwardly-extending arms supported from the sides of the standards 40, and carrying at their ends rollers or turning shafts 43, which are used when the paper is being printed on both sides. The platen consists of a block or plate of metal *N*, the cheek or side pieces *n* of which are perforated and hung upon the shaft 37, so as to turn thereon. To this plate or block is secured in any suitable manner, as by the bolts 39, the bed or plate *O*, which forms the platen proper, and which may be of any preferred construction. By hanging the platen upon the shaft 37, so as under proper circumstances to be free to turn thereon into the position shown in Fig. 6, the work of "making ready" the platen—that is, adjusting the yielding face thereof so as to secure a good impression—is rendered easy, since it is not necessary to work in the contracted space between the platen and the form, as would be the case were the platen fixed immovably in its frame. It is to be understood that in a machine constructed and proportioned as shown the roll of paper is to be removed and its standards slid or turned out of the way before the platen can be turned up.

In order that the platen may be always stopped in exactly the proper working position when turned down, I provide it with a stop consisting of a lug or plate 44, projecting from the plate *N* and bearing against a fixed abutment, such as the cross bar or piece 45 between the plates *k* of the platen-frame.

n' n' are perforated lugs carried, respectively, by the plate *N* of the platen and the platen-frame, and adapted, when the platen is turned into working position, to have their perforations register to receive a key, pin, bolt, or other locking device 47 for holding the platen in position. By arranging the beds for

the forms at the ends of the main or central part of the machine and the platens outside thereof the latter are the more accessible for the purpose of making ready and the like than in those machines wherein the platens reciprocate between the beds which face inward toward each other.

I will now describe the devices whereby the paper is fed through the machine, is cut, and is delivered in printed sheets. These paper feeding and piling devices are arranged substantially horizontally, so that the sheets as they are severed and delivered lie flat and may be conveniently piled one upon another, as they are by the fly-delivery mechanism now in common use, but by a mechanism occupying less space and operating with less friction and noise. From the roll 41 the paper passes downward in front of the platen, between it and the form, from which it receives an impression at each reciprocation of the platen. After being printed upon the paper passes to a paper carrying or feeding device situated below the platen in the end portion *A* of the main frame-work.

The paper feeding and piling devices consist of two sliding frames connected to be moved in the same direction and at substantially the same time, and provided with gripping devices which grasp the paper, and a cutting and paper-clamping device is situated between the said sliding frames. The sliding frame to which the paper is first delivered after passing the turning shaft or roll 46 is represented generally by the letter *P*. It consists of two end pieces 49, sliding in ways 48 on the stationary frame and connected by a cross-plate 50, adjacent to which the paper passes and against which it is clamped by nippers 51, secured to a transverse shaft 52, mounted in the end pieces 49. The frame *P* and the nippers 51 receive their motions from a cam or eccentric *Q* on the shaft *E'*, which operates upon a roller on the end of a lever *R*, fulcrumed on a standard *r*. The lever *R* is connected by a rod *S* with an arm 53, secured to the shaft carrying the nippers, so that when the rod is forced forward in the direction of the arrow, Fig. 4, it first causes the shaft 52 to be rocked, bringing the nippers against the under face of the cross-piece 50, and thereby clamping the paper. The engagement of the nippers with the piece 50 stops the rotation of the shaft 52, but the rod *S*, continuing to move, operates to carry forward the frame *P*, and with it the paper, which is tightly grasped. The frame *P* moves in the ways with sufficient friction to insure that the shaft shall be rocked and the paper positively grasped before it begins its forward motion, otherwise the feeding would be irregular, since the frame might be moved without the nippers operating at all. The paper-feeding frame *P* is brought back to the position shown in Fig. 4 by a spring *T*, coiled around the rod *S* between a collar *s* thereon and a stationary abutment *t* carried by the

frame-work of the machine, which spring likewise holds the end of the lever R toward the eccentric Q.

In order to regulate the extent of movement of the feeding-frame, so that a greater or less amount of paper shall be fed thereby at each reciprocation, so as to suit the size of the job being worked off, I provide an adjustable stop 54, adapted to be moved into the path of the lever R, so as to hold the free end thereof away from the eccentric Q for a greater or less extent of its revolution.

U is a second frame for delivering and piling the sheets of paper, constructed substantially like the frame P and also carrying a set of nippers, and sliding in the ways 48 in front of the frame P. The nippers 55 of this frame U are mounted upon a shaft 56, and are brought to bear against the cross-plate 58 by the rocking of the shaft, which is provided with crank-arms 57, connected by the links V with the frame P. The nippers 55 operate, as do the nippers 51, to catch the paper before their frame commences its forward movement, and since the forward frame U takes its motion from the rear one it follows that the paper is fed forward a certain distance by the frame P before it is caught by nippers of the frame U. The reason for this arrangement and operation is to cause the paper to be fed forward by the rear set of nippers a short distance beyond a knife which severs the printed paper into sheets, so that its edge will project sufficiently far beyond the same to be caught by the nippers of the delivering-frame. The links V are slotted at *v*, so that the connection between the two frames P and U is adjustable, permitting the outer frame to be moved toward or from the inner one into the position best suited for the work being done.

The nipper-shafts 52 and 56 are provided with suitable stops to limit the amount of motion which may be imparted thereto.

The knife or cutter, which severs the paper into sheets, is situated between the frames P and U, and consists of a stationary blade or plate *w*, carried by a cross-bar 60 of their main frame-work, and a movable blade W, supported by a vertically-reciprocated carrier X. The knife-blade carrier X is supported upon guide pins or rods 61 on the main frame-work, and is forced toward the stationary blade *w* by the springs 62, which encircle the rods 61. The carrier X is provided with brackets *x*, which carry rollers 63, beneath which are adapted to slide wedge-bars which lift the carrier X against the action of the springs 62 and separate the knife-blades.

The lifting-wedges 64 (best shown in Fig. 6) are carried by a frame supported so as to slide upon the ways 65 on the main frame-work beneath the platen. This sliding frame preferably consists of a lower plate 66, which carries at its front edge the wedge 64, an upper plate 67, provided at its opposite ends

with abutments 68, and a cross connecting-bar 69 situated between the said plates.

69' are lugs or projections extending downward from the platen-frame between the abutments 68 on the sliding wedge-frames, with which they are adapted to engage at the extremes of the movement of the platen-frame to effect a sliding of the wedge-bars to operate the knife. The relative relation of the abutments on the wedge-frame and the projection on the platen-frame, and the timing of the various operative connections is such that the carrier X is elevated and the knife-blades separated during the time the paper is being fed forward, but is lowered immediately they begin their backward movement.

70 is a plate secured to the rear face of the carrier X by the screws 71, upon which it slides, the plate being slotted to permit this movement. A spring 72, carried by the carrier X, bears upon the upper edge of this plate and causes its lower edge to project slightly beyond the edge of the knife-blade W. When the carrier is depressed, the edge of the plate 70 bears against the cross-bar 60 just back of the knife and serves to hold the edge of the paper after it has been cut, and permit the inner feeder from drawing it back with it. It will be understood that when the knife-carrier is elevated by the wedges the clamping-plate is carried therewith, so as to leave a free space on the cross-bar 60 and knife-blade *w* for the paper.

As hereinbefore stated, a machine constructed as shown and described herein is adapted to print both sides of a web of paper, and in Fig. 1 the course the paper takes when being so printed is indicated. The paper from the roll 41^a passes to the printing and feeding devices at the right-hand end of the machine, which operate in the usual manner, except that the cutting devices are adjusted so as not to sever the paper, or else are removed from the machine entirely. After passing the outer feeding-frame the paper turns around the rod or roller 73 at the end of the frame, and passes back over the top of the machine, following the course indicated by the dotted lines, and being supported by the rods or bars 74, mounted in the upper ends of the removable standards 75. From the last rod 74 the web of paper passes to the turning roller or rod 43, mounted in the arms 42, and thence passes to the printing, feeding, cutting, and delivering devices at the left-hand end of the machine, where the paper cut into sheets printed upon both sides is piled.

A machine of the character described has almost unlimited capabilities as to speed, and yet works smooth and with less jar than is experienced in rapidly operating the ordinary single-platen presses now in vogue. The machine being once set in motion operates automatically, only requiring the services of an attendant to see that the parts are prop-

erly performing their respective functions. Each end of the machine having its independent driving and adjusting devices, it becomes possible to print at the same time upon the opposite forms jobs differing to any extent (within the capacity of the machine) in size, shape, or matter.

It will be understood that many of the parts may be changed in their connection and arrangement without departing from my invention; therefore without limiting myself to the precise construction and arrangement of parts shown,

I claim—

1. In a duplex printing-machine, the platens and beds for the form near the ends of the machine, the inking devices and the operating mechanism arranged between the beds and platens, the supports for the rolls of paper outside of the platens and beds, and the paper feeding and piling devices at the extreme ends of the machine, substantially as described and shown.

2. In a printing-press, the combination, with a bed and platen, of the supports for a roll of paper, a horizontally-arranged reciprocating paper-feeding frame, a similarly-arranged reciprocating delivering-frame, and a paper-cutter arranged between the two frames, substantially as described.

3. In a printing-machine, the combination, with the impression devices, of a paper-feeding frame, operative connections for imparting reciprocating motions to the frame, which include a lever, a cam or eccentric which operates upon the said lever to move the said connections, and an adjustable stop engaging with the said lever and regulating the extent to which it is moved by the said cam or eccentric, substantially as described.

4. In a reciprocating printing-press, the combination, with the impression devices, of a horizontally-arranged reciprocating frame, a rock-shaft mounted therein carrying nippers, a reciprocating rod connected with a crank-arm of the rock-shaft, a cam or eccentric for moving the rod in one direction, an adjustable stop which regulates the amount of motion imparted to the rod by the cam or eccentric, and a spring which moves the rod in the direction opposite to that which the cam or eccentric moves it, substantially as described.

5. In a printing-press, the combination, with the impression devices, of a paper-feeding frame and a paper-delivery frame, each provided with a rock-shaft carrying paper-nippers, the rock-shaft of the delivering-frame being connected with the feeding-frame by a link, which link rocks the said shaft and also moves the frame, substantially as described.

6. The combination, with the impression devices, of the sliding frame P, the nippers supported on a rock-shaft mounted therein, a reciprocating rod connected with an arm of the shaft to rock it and also to move the

frame, a second sliding frame U in front of the frame P, also provided with nippers supported upon a rock-shaft, and the link or links connecting the frame P with an arm projecting from the shaft of the frame U, substantially as described.

7. In a reciprocating printing-press, the combination, with the impression devices, of two horizontally-arranged reciprocating frames mounted one in front of the other and each provided with paper-nippers, the paper-cutter mounted between the two frames, and driving devices, substantially as described, to commence the movement of the inner frame before the outer frame begins to move, whereby the paper is by the first frame fed beyond the knife to the outer frame before the latter moves, substantially as described.

8. In a printing-press, the combination of the two beds for the forms at the opposite ends or sides of the machine, the two platens arranged outside of the two beds, the driving-shaft situated between the two beds, and connections between the said shaft and the platens for reciprocating them toward and from the beds, substantially as described.

9. A printing-press having the main frame with the central portion A', provided at its ends with the beds for the forms and with the end portions A, having the ways or slides for the platen-frames, the platens mounted in frames arranged outside of and opposite the said beds, and the mechanism for reciprocating the platen-frame mounted upon the central portion A' of the frame, substantially as described.

10. In a printing-press, the combination of the two beds at the opposite ends of the stationary frame-work, the frame carrying the two platens, the two shafts E', mounted in the stationary frame-work between the beds and provided with crank or wrist wheels, and the pitmen connecting the wrists of the wheels with the opposite ends of the platen-frame, substantially as described.

11. In a platen printing-press, the combination of the reciprocating paper-feeding devices, a knife operated by springs, and means operated by the platen for moving the knife against the action of the springs to permit the feeding of the paper past the knife, substantially as described.

12. In a printing-press, the combination of the paper-feeding devices, a knife, the springs which move the knife in one direction, and a sliding frame carrying a wedge block or blocks which move the knife against the action of the springs, substantially as described.

13. In a platen printing-press, the combination of the paper-feeding devices, the knife, and a sliding frame moved by the platen-frame for operating the knife, substantially as described.

14. In a platen printing-press, the combination of the paper-feeding devices, the knife sliding across the path of the paper upon supports on the stationary frame-work of the

press, the reciprocating platen-frame, and sliding wedges operated by the platen-frame for moving the knife, substantially as described.

5 15. The combination of the paper-feeding devices, the reciprocating spring-pressed knife, the wedges 64 for moving the knife against the action of the springs, the sliding plate 67, provided with the abutments 68, and
10 connected with the wedges, and a lug carried by the platen-frame and movable between the abutments 68, with which it engages to give motion to the wedges, substantially as described.

15 16. In a printing-press, the combination of the main frame-work having the sides pieces 3, between which are supported the bed for the form, and an ink-plate, independent ink-rollers for delivering the ink to the plate and for
20 taking it therefrom to the form, and independently-operated swinging frames in which the said rollers are mounted, one of the frames moving upon the outside of the side pieces 3 and the other upon the inside, substantially as described.
25

17. In a duplex platen printing-press, the combination of the main frame-work, the inking devices mounted on the top of the main frame-work, the beds for the forms at the ends
30 thereof, and the curved spreading-plates 5 on the main frame-work between the top and end portions thereof, substantially as described.

18. The combination, with the ink-plate, of the roller 23, the swinging frame in which the roller is mounted, having an adjustable contact-piece 25 and an arm 28, a cam mounted
35 upon a rock-shaft therefor and arranged to bear upon the said contact-piece to move the frame in one direction, and a spring bearing upon the arm 28 to move the frame, substantially as described. 40

19. In a printing-press, the combination, with an ink-roller free to move longitudinally, and the reciprocating platen-frame, of a rock-shaft having an arm connected to move the
45 roller, a gear-wheel on the rock-shaft, and a rack on the platen-frame meshing with the gear-wheel, substantially as described.

20. A duplex platen printing-machine having two sets of impression devices, independent paper-feeding devices adjacent to each
50 set of impression devices, standards for supporting a roll of paper in position to be fed to one set of impression devices, and paper-guides arranged to direct the paper from the
55 last said set of impression devices to the other impression devices, substantially as described.

In testimony whereof I have hereunto signed my name.

BERNARD H. SPECKBAUCH.

Witnesses:

H. REUTER,
JAS. KNECHT.