

Nov. 11, 1947.

W. J. FOSTER

2,430,763

CLOTHESPIN BAG

Filed Oct. 23, 1943

Fig. 1.

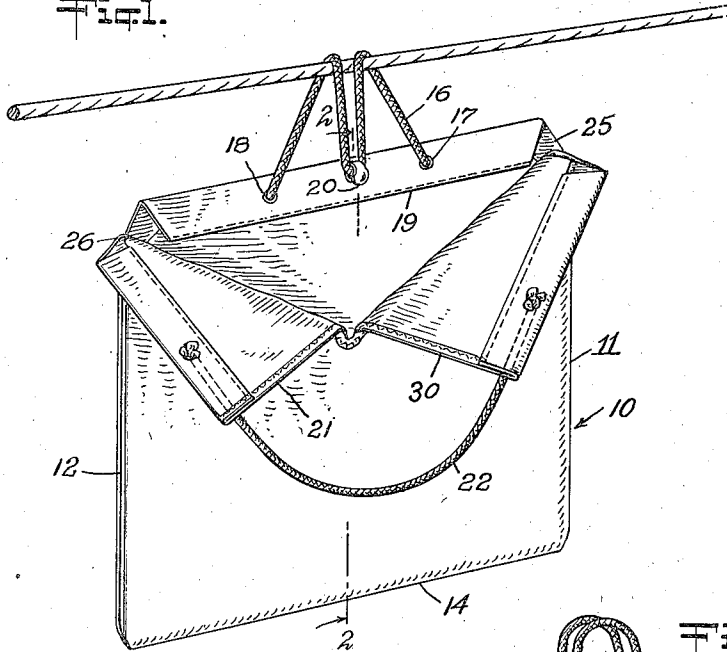

Fig. 2.

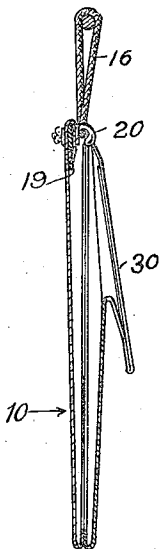

Fig. 3.

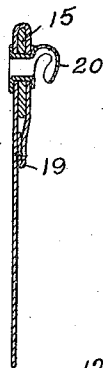
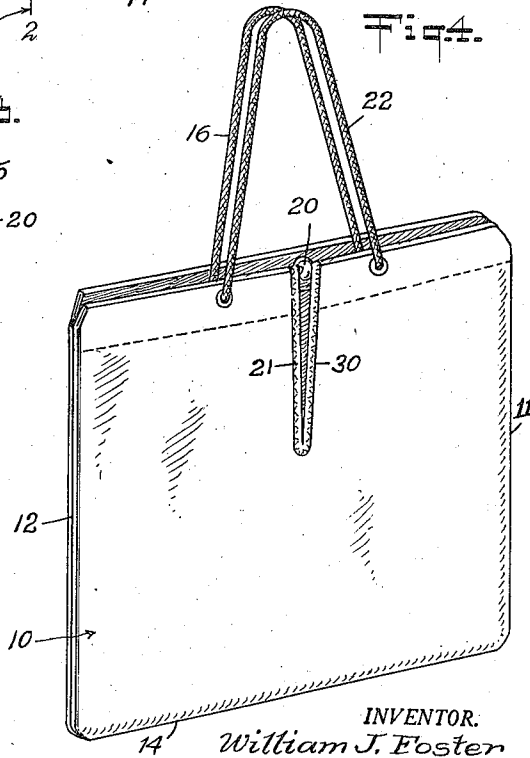

Fig. 4.



Witnesses
George Taylor
John G. Laccum

INVENTOR.
William J. Foster
BY
Munn, Liddy & Glacum
Attorneys

UNITED STATES PATENT OFFICE

2,430,763

CLOTHESPIN BAG

William J. Foster, Ridgefield Park, N. J.

Application October 23, 1943, Serial No. 507,396

1 Claim. (Cl. 150—1.8)

1

This invention relates to a utility bag and more particularly a bag which may be used for clothespins, shopping, to carry sewing, knitting, or for any similar purpose.

An object of the invention is to provide a bag of simple construction which, when carried in a normal way, will remain closed but which, when held by only one handle, will automatically open and give ready access to the interior thereof.

A further object is to provide a bag of the type described which may be used for any purpose and which will be simple in construction and economical to manufacture.

Another object of the invention is to provide a bag which may readily be hung on a hook, over a clothesline, or in any other convenient place.

Other objects and advantages will become apparent as the description proceeds.

In the accompanying drawings—

Figure 1 is a perspective view of my bag supported by one handle;

Fig. 2 is a cross sectional view on the line 2—2 of Fig. 1;

Fig. 3 is an enlarged detail view showing the hook member;

Fig. 4 is a perspective view of the bag in closed position.

My bag 10 may be made from a single piece of material folded upon itself and stitched along the edges 11 and 12 or it may be made of two pieces sewn together at the edges 11 and 12 and at the bottom 14. One end is folded upon itself over a strip of wood 15 which tends to give this edge of the bag rigidity. A flexible handle member 16 is attached through the openings 17 and 18 and the end is stitched at 19. A hook member 20 of any desired type is supplied to engage the flexible handle member 16 when it is desired to hang the bag over a clothesline.

The other end of the bag is slotted to form two halves 21 and 30 provided with a flexible handle member 22. It will be seen that when the handle members are held together the handle member 22 draws the sections 21 and 30 together and the bag remains closed. However, when the handle member 22 is released sections 21 and 30 immediately drop down so that the bag is in open position. This is facilitated if the sides 25 and 26 are left open for a few inches. In other words, the stitches 11 and 12 are discontinued a short distance from the top of the bag.

While I have shown my bag as used as a clothespin bag it will be appreciated that it may be put to many other uses as heretofore stated and I do not wish to be limited in its use.

2

I claim:

A clothespin bag having a front panel and a rear panel joined at the bottom and at the sides up to a predetermined point which is short of the top, said front and rear panels being free from each other at the top and providing an opening at the top into the bag, said front panel having a vertical slit formed centrally thereof from its top edge to a point substantially midway between its top and bottom edges, two holes formed at the top of the front panel, one on each side of the slit, a flexible handle extending through said holes, said handle being knotted at both ends to prevent it from coming through the holes, said handle being adapted when held in carrying position, to support the front panel of the bag and to hold its slitted upper portion in closed upright position relative to the rest of the bag, said handle being sufficiently long, when released to allow the slitted upper portion of the front panel to fold over forwardly and downwardly to open the bag, said rear panel being provided with a horizontal stiffening member and with a hook affixed centrally thereof, holes formed in said stiffening member and in the top of said rear panel, one on each side of the hook, a second flexible handle extending through said holes, said second handle also being knotted at its two ends to prevent said handle from coming through the holes, said handle being sufficiently long and flexible to loop over a clothesline and to engage the hook, whereby the clothespin bag may be suspended from the clothesline, said second flexible handle being also adapted, in cooperation with the first handle, to carry the bag.

WILLIAM J. FOSTER.

REFERENCES CITED

The following references are of record in the file of this patent:

UNITED STATES PATENTS

Number	Name	Date
2,165,869	Mathiesen	July 11, 1939
1,347,704	Meyer	July 27, 1920
1,346,033	Keith et al.	July 6, 1920
1,207,638	Sandt	Dec. 5, 1916
1,538,022	Brekke	May 19, 1925
2,352,102	Johnston	June 20, 1944

FOREIGN PATENTS

Number	Country	Date
805,917	France	Sept. 7, 1936
94,783	Switzerland	Mar. 16, 1922