

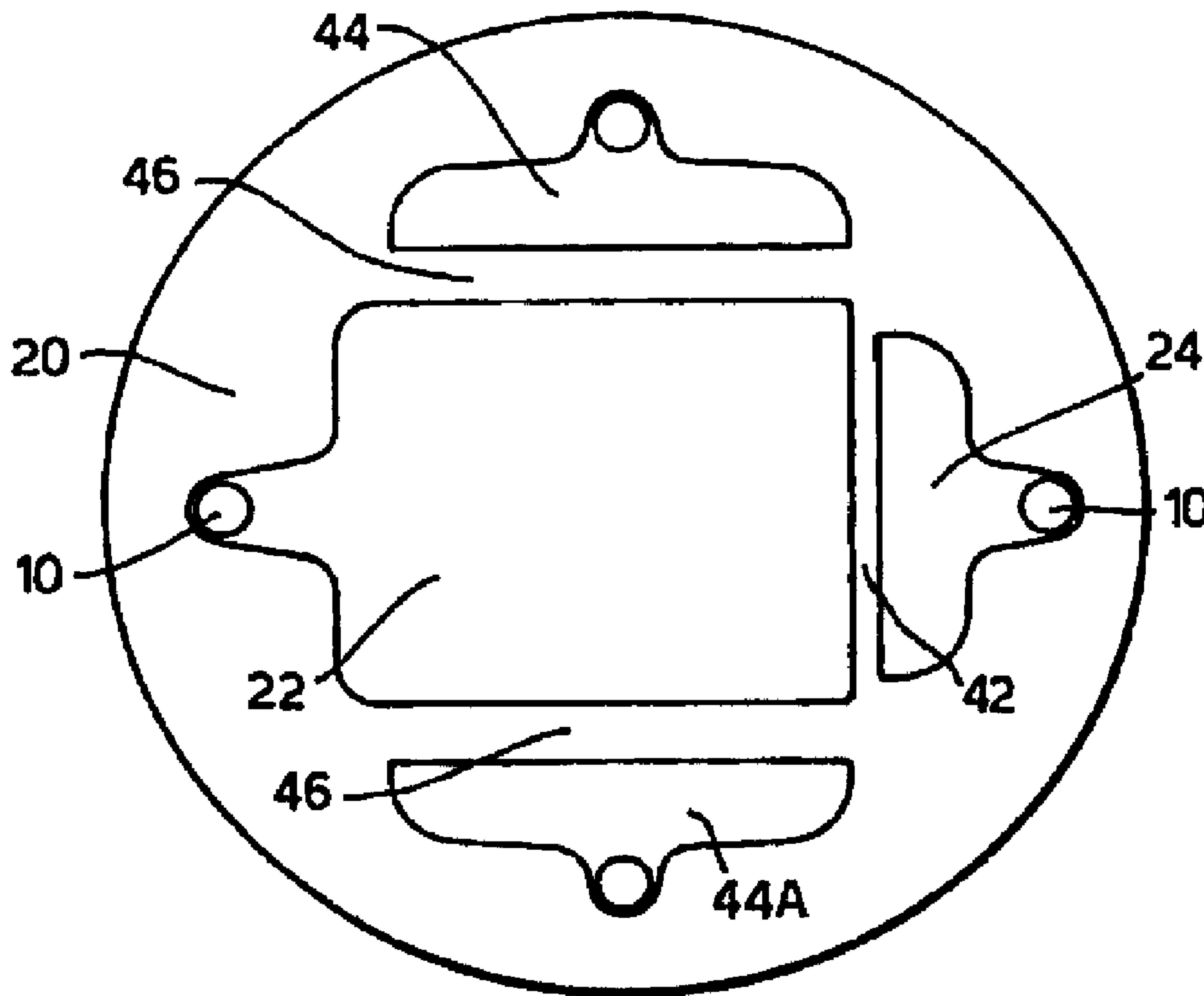

(86) Date de dépôt PCT/PCT Filing Date: 1997/12/05
 (87) Date publication PCT/PCT Publication Date: 1998/06/11
 (45) Date de délivrance/Issue Date: 2004/02/10
 (85) Entrée phase nationale/National Entry: 1999/06/03
 (86) N° demande PCT/PCT Application No.: GB 1997/003377
 (87) N° publication PCT/PCT Publication No.: 1998/025139
 (30) Priorité/Priority: 1996/12/07 (9625463.6) GB

(51) Cl.Int.⁶/Int.Cl.⁶ G01N 27/26, G01N 27/49, G01N 27/416, G01N 37/00
 (72) Inventeurs/Inventors:
 DODGSON, JOHN ROBERT, GB;
 ROBINS, IAN, GB;
 AUSTEN, MALCOLM TRAYTON, GB
 (73) Propriétaire/Owner:
 CENTRAL RESEARCH LABORATORIES LIMITED, GB
 (74) Agent: RIDOUT & MAYBEE LLP

(54) Titre : DETECTEURS DE GAZ
 (54) Title: GAS SENSORS



(57) Abrégé/Abstract:

A gas sensor including a housing containing at least a sensing electrode (22), a counter electrode (44, 44A), a test electrode (24), and electrolyte means in contact with such electrodes (22, 24, 44, 44A). The housing permit is gas from the environment to flow to the sensing electrode (22). The gas sensor is operable either in a normal mode of operation in which potentials are applied to the electrodes (22, 44) for detecting when a gas to be sensed is present at the sensing electrode (22), or in a test mode of operation in which potentials are applied to the electrodes (22, 44, 44A, 24) so that the test electrode (24) generates a gas which flows to the sensing electrode (22) to enable an indication whether the sensor is operating correctly.

PCT

WORLD INTELLECTUAL PROPERTY ORGANIZATION
International Bureau

INTERNATIONAL APPLICATION PUBLISHED UNDER THE PATENT COOPERATION TREATY (PCT)

<p>(51) International Patent Classification⁶ : G01N 33/00, 27/416, 27/49</p>	A1	<p>(11) International Publication Number: WO 98/25139</p> <p>(43) International Publication Date: 11 June 1998 (11.06.98)</p>
<p>(21) International Application Number: PCT/GB97/03377</p> <p>(22) International Filing Date: 5 December 1997 (05.12.97)</p> <p>(30) Priority Data: 9625463.6 7 December 1996 (07.12.96) GB</p> <p>(71) Applicant (for all designated States except US): CENTRAL RESEARCH LABORATORIES LIMITED [GB/GB]; Dawley Road, Hayes, Middlesex UB3 1HH (GB).</p> <p>(72) Inventors; and (75) Inventors/Applicants (for US only): DODGSON, John, Robert [GB/GB]; 71 Ballards Way, Croydon, Surrey CR2 7JP (GB). ROBINS, Ian [GB/GB]; 29 Lees Road, Hillingdon, Middlesex UB8 3AS (GB). AUSTEN, Malcolm, Trayton [GB/GB]; 6 Moray Avenue, Hayes, Middlesex UB3 2AU (GB).</p> <p>(74) Agent: LEAMAN, Keith; QED Patents Limited, Dawley Road, Hayes, Middlesex UB3 1HH (GB).</p>	<p>(81) Designated States: CA, CN, JP, KR, MX, SG, US, European patent (AT, BE, CH, DE, DK, ES, FI, FR, GB, GR, IE, IT, LU, MC, NL, PT, SE).</p> <p>Published <i>With international search report. Before the expiration of the time limit for amending the claims and to be republished in the event of the receipt of amendments.</i></p>	

(54) Title: GAS SENSORS

(57) Abstract

A gas sensor including a housing containing at least a sensing electrode (22), a counter electrode (44, 44A), a test electrode (24), and electrolyte means in contact with such electrodes (22, 24, 44, 44A). The housing permit is gas from the environment to flow to the sensing electrode (22). The gas sensor is operable either in a normal mode of operation in which potentials are applied to the electrodes (22, 44) for detecting when a gas to be sensed is present at the sensing electrode (22), or in a test mode of operation in which potentials are applied to the electrodes (22, 44, 44A, 24) so that the test electrode (24) generates a gas which flows to the sensing electrode (22) to enable an indication whether the sensor is operating correctly.

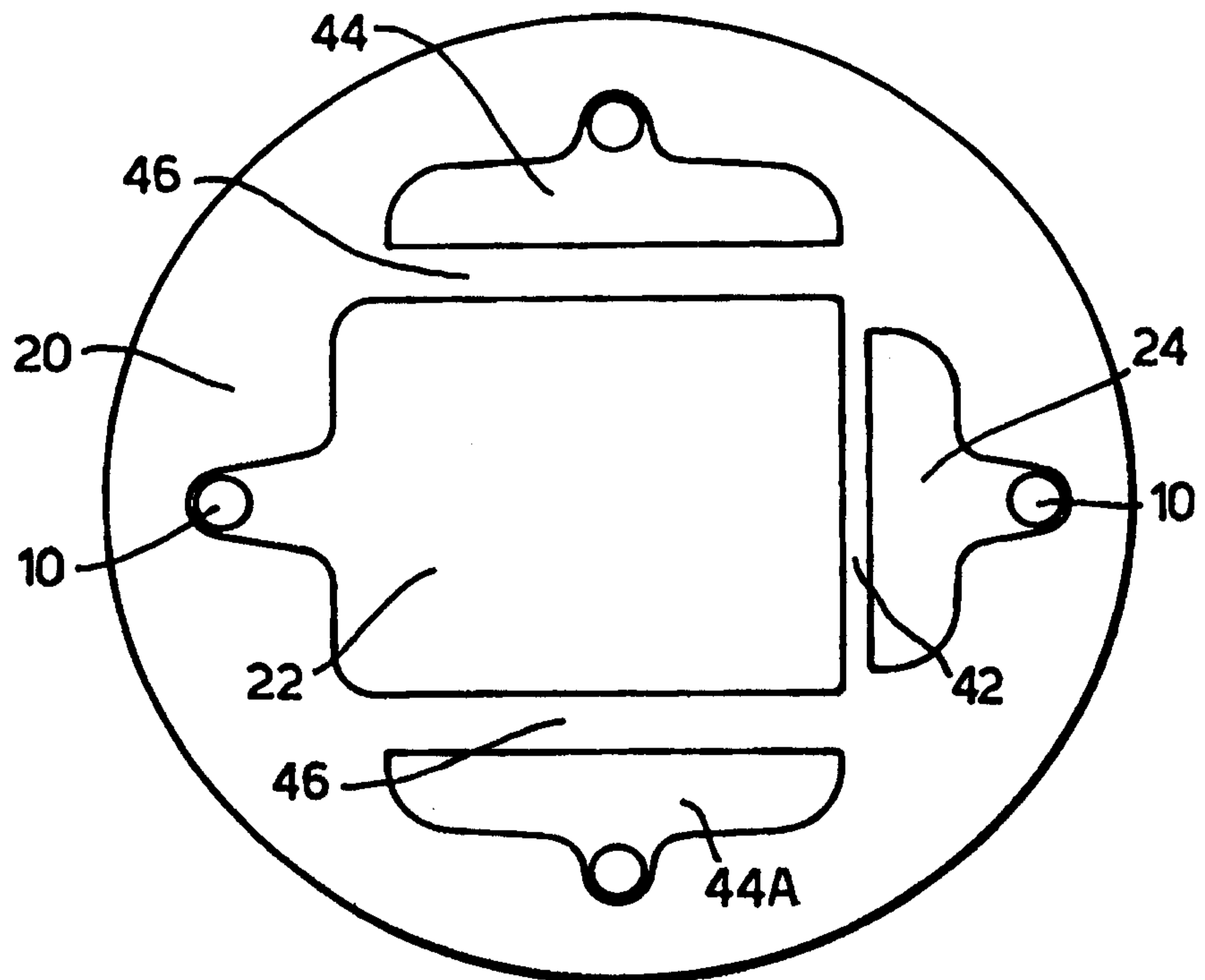

Gas Sensors

This invention relates to gas sensors with a capability for self-testing.

5

Conventional electrochemical gas sensors operate by oxidising the gas at a sensing electrode, thereby generating a current. The rate of access to the electrode is determined by a diffusion barrier, and the rate at which the electrode can oxidise the gas is arranged to be very much greater than the rate at which gas diffuses through the barrier. Therefore the rate of oxidation, and hence the current, is controlled solely by diffusion, and this is a known value (for a given gas concentration) when the sensor is manufactured. If the activity of the electrode falls with time e.g. through poisoning, then the current eventually becomes limited by the lowered oxidation rate at the electrode and the sensitivity of the sensor falls. The sensor does not fail safe - there is no way of telling from the cell output whether the gas concentration is low, or the concentration is higher and the electrode has lost activity.

Reliability of such sensors is ascertained by regular tests involving exposure to a calibration gas. In many situations, for example in a domestic CO safety monitor, this is undesirable. A sensor with a self test function, either triggered remotely or locally, would be highly advantageous.

GB-A-1,552,538 describes a self-test sensor assembly consisting of two parts, a sensor and a gas generation means, for example an electrolysis cell, joined by a delivery channel. Test gas is delivered directly to the sensing electrode of the sensor, with a membrane between the point of gas delivery and the outside world. Delivery is by a piston, a pressure difference resulting from the generation of gas itself, or other means. Signal gas enters the sensor from the atmosphere via the membrane. In this arrangement the concentration of test gas seen by the sensing electrode depends on the balance of the rate of generation of the gas and the rate of loss through the membrane - the latter depends on the conditions (air flow) outside the membrane. As the generator is remote from the sensing electrode, there is a large volume to be filled with gas in order to ensure

that a consistent known concentration is reached. This means the design is likely to require significant power, which is a limitation of the use of such a principle in a low power domestic monitor circuit.

5 GB-A-2245711 describes a gas sensor with solid electrolyte layers disposed on two sets of electrodes, one designed for a gas sensing function, and the other set provided for a test function. The test function electrodes are arranged to sense a gas normally present in the atmosphere, e.g. oxygen. A decrease in the signal from the test electrodes is taken to indicate either a decrease in activity of the test electrodes, or a decrease in
10 the permeability of the solid electrolyte, through which test and signal gas must pass before they reach the electrodes. Such change in permeability is a major factor in the performance of the sensor type disclosed in GB-A-2245711. The test of electrode decay rests on the assumption that the test electrodes will decay in the same way as the sensing electrodes. The test reaction using O₂ is fundamentally different from the sensing
15 reaction for oxidisable gases, being a reduction rather than an oxidation reaction, and so this form of test is likely to prove unreliable. A test where the sensing electrode oxidises test gas generated in known quantity, as in GB-A-1,552,538 would be advantageous.

The present invention provides a gas sensor including a housing containing at
20 least a sensing electrode, a counter electrode, a test electrode, and electrolyte means in contact with such electrodes, the housing permitting gas from the environment to flow to the sensing electrode, and the gas sensor being such as to be operable either in a normal mode of operation in which potentials are applied to the electrodes for detecting when a gas to be sensed is present at the sensing electrode, or in a test mode of operation in
25 which potentials are applied to the electrodes so that the test electrode generates a gas which flows to the sensing electrode to enable an indication whether the sensor is operating correctly.

Thus in accordance with the invention a cheap and accurate means is provided of
30 self-testing, wherein the test gas is generated internally of the sensor and in a controlled amount by application of a suitable voltage potential.

A gas sensor according to claim 1 comprising of a planar arrangement of one or more sensing electrodes and one or more electrolytic generation electrodes on a common substrate in contact with common or separate electrolytes with associated counter and reference electrodes as may be required, such that the generation electrodes are close to the sensing electrodes, so as to minimise the amount of gas that is needed to effect the test. The gas might be delivered to the sensing electrode in the gas phase, by evolution into a communicating space above the electrodes, and access from generating to sensing electrodes might be via a diffusion barrier. The gas might alternatively be delivered to the sensing electrode in solution. The latter will give a measure of electrode activity different from, but related to, the activity measured for gas phase reaction, but will still give an indication of performance.

In a preferred embodiment, the planar arrangement of generating and sensing electrodes gives close proximity and small generated volume - hence low power and fast response. More than one generating electrode may be placed around the sensing or sensing electrode to further improve fast response and further reduce power requirements. An interleaved array of generating and sensing electrodes may also be employed. As preferred, screen printed electrodes and assembly method as described in our copending application WO 96/14576 (ref. PQ 12,622) is employed, that is: providing electrodes as porous planar elements on a substrate, a housing containing an electrolyte reservoir, and electrical terminals; positioning the substrate relative to the housing so that a portion of an electrode is positioned adjacent an electrical terminal; and bonding the substrate to the housing so that the electrode is electrically connected with the electrical terminal means while the porosity of the electrode is blocked in the region of the electrical connection to prevent permeation of electrolyte to the electrical connection. The electrodes are preferably formed of a porous electrically conductive material containing PTFE or similar polymeric binder, preferably particles of catalyst, and optional additional catalyst support material and material to enhance conductivity. The electrodes might be deposited onto the substrate by for example screen printing, filtering in selected areas from a suspension placed onto the substrate, by spray coating, or any

other method suitable for producing a patterned deposition of solid material. Deposition might be of a single material or of more than one material sequentially in layers, so as for

example to vary the properties of the electrode material through its thickness or to add a second layer of increased electrical conductivity above or below the layer which is the main site of gas reaction. The preferred metal deposit is platinum or platinum/; carbon, although other deposits may be employed such as carbon or ruthenium dioxide.

The generator electrode may be placed close to the diffusion barrier inlet for signal gas, so that in self-test, some gas is lost to the outside and some is oxidised by the sensing electrode. If the diffusion barrier becomes blocked, the concentration seen by the sensing electrode during self-test is higher than would be the case without blockage, thus providing a means of checking whether the diffusion barrier is blocked. The accuracy of this check can be improved by delivering the test gas between two diffusion barriers.

Two levels of test may be provided: (1) a quick check of sensor function by generating gas in solution, which then diffuses to the sensing electrode through the solution - this uses low power; and (2) a check on diffusion barrier blockage, which might also give a calibration of the sensor, in which gas is delivered to the sensing electrode in the gas phase as above. The cell may be provided with two generating electrodes - a submerged electrode without access to the gas phase for the first test, and an electrode on a porous substrate communicating with the gas phase for the second.

An actuator may be incorporated into the cell to close the diffusion barrier during self test. This would remove the effect of air currents on the test result. Comparison of open and closed responses test for blockage of the barrier - if there is no blockage, the closed response will be greater than the open response.

Brief Description of the Drawings

Preferred embodiments of the invention will now be described with reference to the accompanying drawings, in which;

5 Figure 1 is a cross-section through a circular gas sensor as employed in the embodiments of the invention;

Figure 2 is a plan view of the electrode configuration of the first embodiment of the invention; Figure 2A is a partial section view along the line 2-2 of Figure 2 to which a cap member has been added.

10 Figure 3 is a plan view of the electrode configuration for a second embodiment of the invention; Figure 3A is a sectional view along the line 3-3 to which a cap member has been added.

Figure 4 is a plan view of the electrode of a third embodiment of the invention; Figure 4A is a section view along the line 4-4.

15 Figure 5 is a sectional view of a fourth embodiment of the invention, with separate electrolyte reservoirs; and

Figure 6A, 6B and 6C are schematic circuit diagrams of a circuit for energising the electrodes of the above embodiments.

Description of the Preferred Embodiment

Referring to Figure 1, this shows a constructions of gas sensor employed in the embodiments of the invention described below. A gas sensor comprises an electrochemical gas sensor 2 comprising a two part housing, namely a body part 4 which is cylindrical with a hollow interior 6 for forming an electrolyte reservoir, a disc-shaped cap member 8. Electrical terminal pins 10 of nickel or tinned copper, have heads 14 thereon located in recesses 16 in the top of the housing body 4. A porous flexible substrate 20 in the form of a disc, is disposed on the upper surface of body member 4. Electrodes 22,24 formed of a mixture of electrically conductive catalyst particles in PTFE binder, are screen printed or filter deposited onto the lower surface of the substrate in the form of segments. A small amount of conductive polymer/carbon composite 26 is placed in recess 16 over each contact pin head 14. The cap member 8 has through holes 28 drilled therein to a recessed manifold area 30 for permitting atmospheric gas to diffuse through the aperture 28 and thence, via manifold area 30, through substrate 20 to electrode 22. Electrolyte within electrolyte recess or reservoir 6 is maintained in contact

with electrodes 22, 24 by means of a wick arrangement 31. To assemble the structure shown in Figure 1, the base part 4 has electrical terminal contact pins 10 positioned therein with conductive polymer or composite 26 positioned within the recesses 16 over the heads 14. The substrate is positioned over the top of the cylindrical body 4. Heat and pressure is applied in the areas A as shown by means of a press tool (not shown) in order to compress the substrate 20 and the electrodes 22, 24 onto the upper plastic surface of housing 4 and the conductive polymer or composite 26 in order to bond the assembly together so that the substrate 20 is securely fixed to the top of the housing 4. The compression of the electrodes 22, 24 and the substrate 20 in the area A, together with the impregnation into the porous substrate 20 of the plastic housing and the conductive polymer or composite 26, ensure that the substrate 20 and electrodes 22,24 are sealed to prevent the ingress of electrolyte into the regions of the electrical connections. Simultaneously, the plastic mass 26 moulds itself around the heads 14 of the terminal pins 10, thereby assuring a good electrical connection between the contact pins and the electrodes 22,24.

In the embodiments described below, an aqueous electrolyte is employed, generating H_2 as the test gas. O_2 is produced at counter electrodes 24 in the electrolytic circuit. The generator cell with separate electrolyte in Figure 5 may use an electrolyte
5 different from that of the sensor in order to generate a specific gas, for example a mixture of potassium bisulphate, sulphur and water for electrolytic generation of H_2S .

Referring now to Figure 2, this shows an electrode configuration of a first embodiment of the invention which may be employed with the structure of Figure 1.

10 In figure 2 similar parts to those shown in Figure 1 are denoted by the same reference numeral. A sensing or sensing electrode 22 occupies the central region of substrate 20 and is coupled at its left hand end (as viewed in Figure 2) to a contact pin 10. A test electrode 24 is separated from the sensing electrode 22 by a narrow channel 42 and connected at its right hand end to an electrical contact pin 10.

15 As shown in Figure 2, two counter electrodes 44 and 44A are shown in two regions adjacent sensing electrode 22 on the same side of the substrate 20 as the electrode 22 and are electrically separated by narrow channels 46.

As shown in Figure 2A, the cap member 8 has a single aperture 48 providing a diffusion barrier to a manifold recess 50, which is dimensioned so the edge of the recess is located above channel 42. The reservoir 6 in the body 4 contains a common aqueous electrolyte in contact with all the electrodes 22, 24, 44, 44A.

In operation, gas from the environment diffuses through aperture 48 to manifold 50. If the air contains a gas to be sensed, for example, CO, an electrochemical reaction is created within electrode 22, an electrochemical reaction is created at the counter electrode 44 with O_2 in the atmosphere, and current is carried through the electrolyte by ions produced in the reactions and by electrons in an external circuit such as that shown in Fig. 6A. The current in the external circuit indicates the CO concentration in the atmosphere. Additionally, a reference electrode might be provided adjacent to the sensing electrode 22, and the reference electrode 61, counter electrode 44 and sensing electrode 22 operated using a potentiostat circuit as in fig. 6B, such circuits being well known in the art.

In order to test whether the gas sensor of Figure 2 is operating correctly, the switch 100 in Figure 6A is employed to apply an electrical potential between electrodes 24 and 44A and thereby activate test electrode 24 in order to generate hydrogen gas, H_2 . This gas migrates across channel 42, through the electrolyte in reservoir 6, as indicated in Figure 2A, to the sensing electrode 22 where it creates a desired electrochemical reaction in order to produce, in the circuit of Figs. 6A or 6B, a current indicative of the H_2 generated is the circuit is operating correctly. O_2 is generated at the second counter electrode 44A to complete gas generation circuit.

The description above describes test gas moving from the generating electrode 24 to the sensing electrode 22 through the electrolyte. An alternative embodiment is shown in cross-section in fig. 2B, where the manifold recess area 50 is dimensioned such that the generating and sensing electrodes 24,22 respectively share a communicating gas space, allowing test gas to pass from the generating electrode 24 to the sensing electrode 22 in the gas phase. This will allow higher concentrations of test gas to be delivered.

space, allowing test gas to pass from the generating electrode 24 to the sensing electrode 22 in the gas phase. This will allow higher concentrations of test gas to be delivered.

5 As a further possibility, there may be only a electrode sensing(22) , reference electrode, test electrode 24 , and a single counter electrode 44 or 44A, and the cell operated with a circuit such as in fig. 6C. In this case, the operation of the sensor will be adversely affected by generation of test gas, and so a changeover switch 120 is provided which has a position in which the cell senses gas, and a second position in which the cell
10 generates test gas. In self-test, test gas is generated for a time, building up a concentration of gas in either the electrolyte in the vicinity of the sensing electrode 22, or a gas space above it. The switch 120 is then moved to the sense position, and the build-up of test gas is sensed.

15 Referring now to Figures 3 and 3A, these show a modified electrode configuration from that of Figure 2, wherein main sensing electrode 52 is generally rectangular in form but having two projecting portions 60 at diagonally opposite corners for connection to contact pins 10. Counter electrodes 44 are provided adjacent the upper and lower sides of the electrode 52. On the lateral sides of electrode 52 are disposed first
20 and second test electrodes 62 separated from electrode 52 by narrow channels 64. In addition, third and fourth counter electrodes 66 are provided, for developing O₂ gas during testing, in strip form and separated from electrodes 62 by narrow channels 68. As may be seen from Figure 3A, test electrodes 64 for generating H₂ are disposed beneath manifold area 50, allowing H₂ to flow on test through the manifold to the sensing
25 electrode, whereas O₂ generating counter electrodes 66 are closed off from the manifold and communicate with the environment by apertures 70 for releasing O₂ gas.

Referring now to Figures 4 and 4A, a further configuration of electrodes is shown, somewhat similar to Figure 2 but wherein a test electrode 70 for generating H₂
30 gas is disposed in the centre of the sensing electrode 22 and with a track 80 leading to electrical contact pin 10. A narrow U-shaped channel 82 separates the electrodes and an underlayer 84 separates track 80 from the electrolyte so that reaction only occurs at the

electrode 70. The underlayer could be achieved by overprinting or heat laminating over the top of the electrode track 70. As shown in Figure 4A, manifold recess encompasses the sensing electrode 22 and H₂ generating electrode 24, but not counter electrodes 44. A diffusion barrier comprising a porous annular member 86 surrounds the gap 82 between the H₂ generating electrode and the sensing electrode. In this embodiment, in the test mode, H₂ gas developed by electrode 70 permeates through manifold 50 via diffusion barrier 86. The H₂ generator electrode 70 is placed closer to the diffusion barrier 86 than is the sensing electrode 22. This allows part of the H₂ to escape through the barrier 86 in test mode. The proportion that escapes is controlled by the permeability of the diffusion barrier 86 and the dimensions of the aperture 48 in the cap 8. The response from the sensing electrode 22 in test mode will depend on the ratio of H₂ escaping to that oxidised at the sensing electrode 22. If the electrode 22 decays, the test response will fall below a pre-determined value. If the diffusion barrier 86 becomes blocked, e.g. by dust from the atmosphere, H₂ will no longer escape and the test response will exceed the value, giving warning of blockage.

Referring now to Figure 5, this is a cross sectional view of a further embodiment employing an electrode configuration as shown in Figure 3, but having a modified electrolyte reservoir construction and manifold construction. As shown, three separate electrolyte reservoirs 90, 92, 94 are provided, reservoir 90 containing an aqueous electrolyte for ensuring normal operation of sensing electrode 22, and reservoirs 92, 94 containing electrolyte for generating O₂ and H₂ during the test phase. As shown, the enlarged manifold area 96 permits both H₂ and O₂ to flow through the manifold area to the sensing electrode 22. This embodiment may be used if it is found that the electrolysis current passing through the common sensing and generation electrolyte in the examples above, disturbs the sensor operation excessively. More than two gas generating cells may be included as required to give fast response, or only one to give low power consumption.

In the above embodiments, an actuator-driven valve may be incorporated in the diffusion barrier to close off the barrier during part of the test cycle, so preventing H₂

being lost to the atmosphere. If the diffusion barrier is blocked then there will be no increase in concentration when the valve is closed and this can then be detected.

The

system might also be used to prevent the influence on the test, of variable loss of H₂ owing to air currents, by closing the valve throughout the self-test process.

Referring to Figures 6A, 6B, 6C, these show a circuit suitable for actuation of the above embodiments. In Fig. 6A, a sensing electrode 22 is coupled in a circuit with a counter electrode 44 with a switch 110 and a source of potential V_s. A test electrode T is

10 coupled in a further circuit with counter electrode 44A, switch 100 and a source of potential V_t. As discussed above all the electrodes are either in contact with a common electrolyte, or with separate electrolytes for the sensing and generation circuits. In operation, switch 110 is closed to allow sensing, and switch 100 closed intermittently to enable test operation. In Fig. 6B, the sensing cell is provided with a reference electrode
15 as well as the sensing and counter electrodes, and operated by a potentiostat circuit.

Switch 110 is closed to enable sensing operation as before, and switch 100 closed intermittently to enable test operation. Switch 110 may be opened while switch 100 is closed, if test gas generation interferes with normal sensing operation of the cell. In Fig.

20 6C, a single counter electrode 49 is provided, and all electrodes are in contact with a common electrolyte. In this case, a changeover switch 120 is provided, which in one position enables sensing operation, and in the other, generates test gas which accumulates in the vicinity of the sensing electrode. The switch is then moved back to the sensing position, the test gas is reacted, and the test function carried out.

CLAIMS

1. A gas sensor comprising a housing containing at least one sensing electrode, at least one counter electrode, at least one test electrode, and at least one electrolyte in contact with at least one of said sensing, test and counter electrodes, wherein the housing permits at least a gas to be sensed to flow from an environment to the sensing electrode, and wherein the gas sensor is operable in a normal mode of operation in which potentials are applied to the electrodes for detecting when the gas to be sensed is present at the sensing electrode, or in a test mode of operation in which potentials are applied to the electrodes so that the test electrode generates a test gas which flows to the sensing electrode to enable an indication whether the sensor is operating correctly; wherein at least two electrodes are mounted side-by-side on the same side of a common porous gas permeable substrate to define a planar electrode assembly; and wherein at least one sensing electrode and said at least one test electrode are mounted side-by-side the same side of said common porous gas permeable substrate and are in contact with a common or separate electrolytes.
2. A gas sensor according to claim 1, wherein one or more counter electrodes and one or more reference electrodes are mounted side-by-side on the same side of the substrate as the sensing electrodes and the test electrodes and are in contact with said common or separate electrolytes.
3. A gas sensor according to claim 1, wherein the test electrodes are in contact with a first electrolyte means and the sensing electrode are in contact with a second electrolyte means.
4. A gas sensor according to claim 1 or claim 3, wherein the one or more test electrodes is positioned and arranged relative to the one or more sensing electrodes so that gas generated by the test electrode or electrodes is evolved into a communicating space in the vicinity of the sensing electrode or electrodes.
5. A gas sensor according to claim 1 or claim 2 wherein a diffusion barrier is provided through which gas generated by the one or more test electrodes passes to reach the sensing electrode or electrodes.
6. A gas sensor according to any one of claims 1 to 5, wherein the or each substrate is a flexible gas permeable membrane that is impermeable to electrolyte.

7. A gas sensor according to any one of claim 1 to 5, wherein said sensing electrode occupies a central region of said substrate, said test electrode is spaced from the sensing electrode by a narrow channel and two counter electrodes are located adjacent the sensing electrode adjacent two sides thereof and are electrically separated by channels.
8. A gas sensor according to claim 7, wherein the electrodes are assembled in said housing which has a cap which has a diffuser hole communicating with a manifold recess adjacent the sensing electrode and an edge of the recess is located between the sensing electrode and the test electrode.
9. A gas sensor according to any one of claims 1 to 6, wherein the sensing electrode is generally rectangular and has two projections forming electrical contacts, first and second counter electrodes are provided adjacent the sensing electrode first and second test electrodes are located on the same side of the substrate as the sensing electrode and third and fourth counter electrodes are mounted on the same side of the substrate on which the sensing electrode is mounted.
10. A gas sensor according to any one of claims 1 to 9, wherein the sensing electrode has a recessed shape and the test electrode is located in the recess, separated by a U-shaped channel, the test electrode is located centrally of the sensing electrode, with a contact strip insulated from the electrolyte extending from the test electrode to an electrical terminal means.
11. A gas sensor according to any one of claim 1 to 10, wherein said housing provides a blockage to flow of gas generated by the test electrode, located such that test gas generated is forced to flow through the electrolyte to the sensing electrode.
12. A gas sensor according to any one of claims 1 to 11, which includes one or more first test electrodes which share a common manifold with the sensing electrode allowing test gas to reach the sensing electrode through the gas phase, and one or more second test electrodes which are excluded from the manifold, whereby test gas from the second test electrodes reaches the sensing electrode only via the electrolyte means with control circuitry to operate the first and second test electrodes in accordance with a test sequence.

13. A gas sensor according to any one of claims 1 to 12, including valve means for closing the housing to the atmosphere during self testing.

Fig.1.

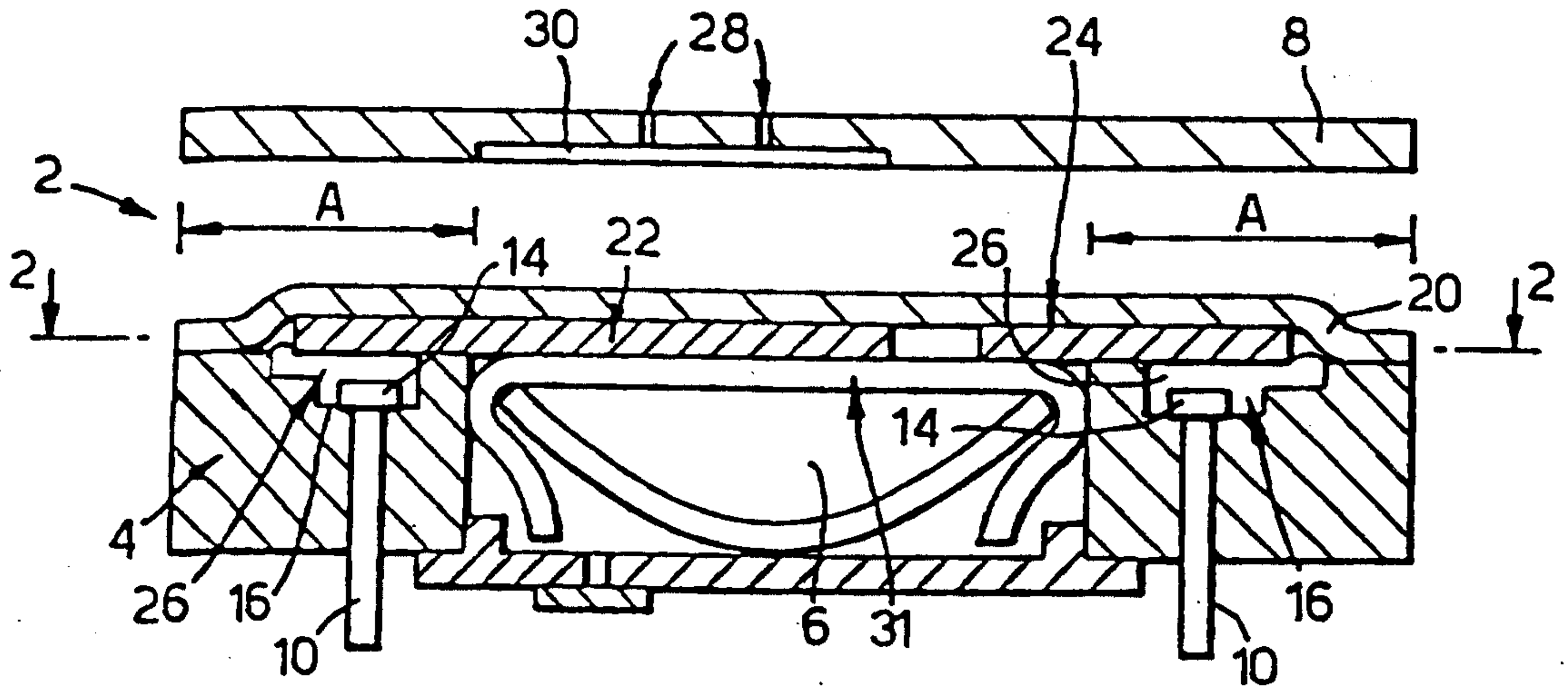

Fig.2.

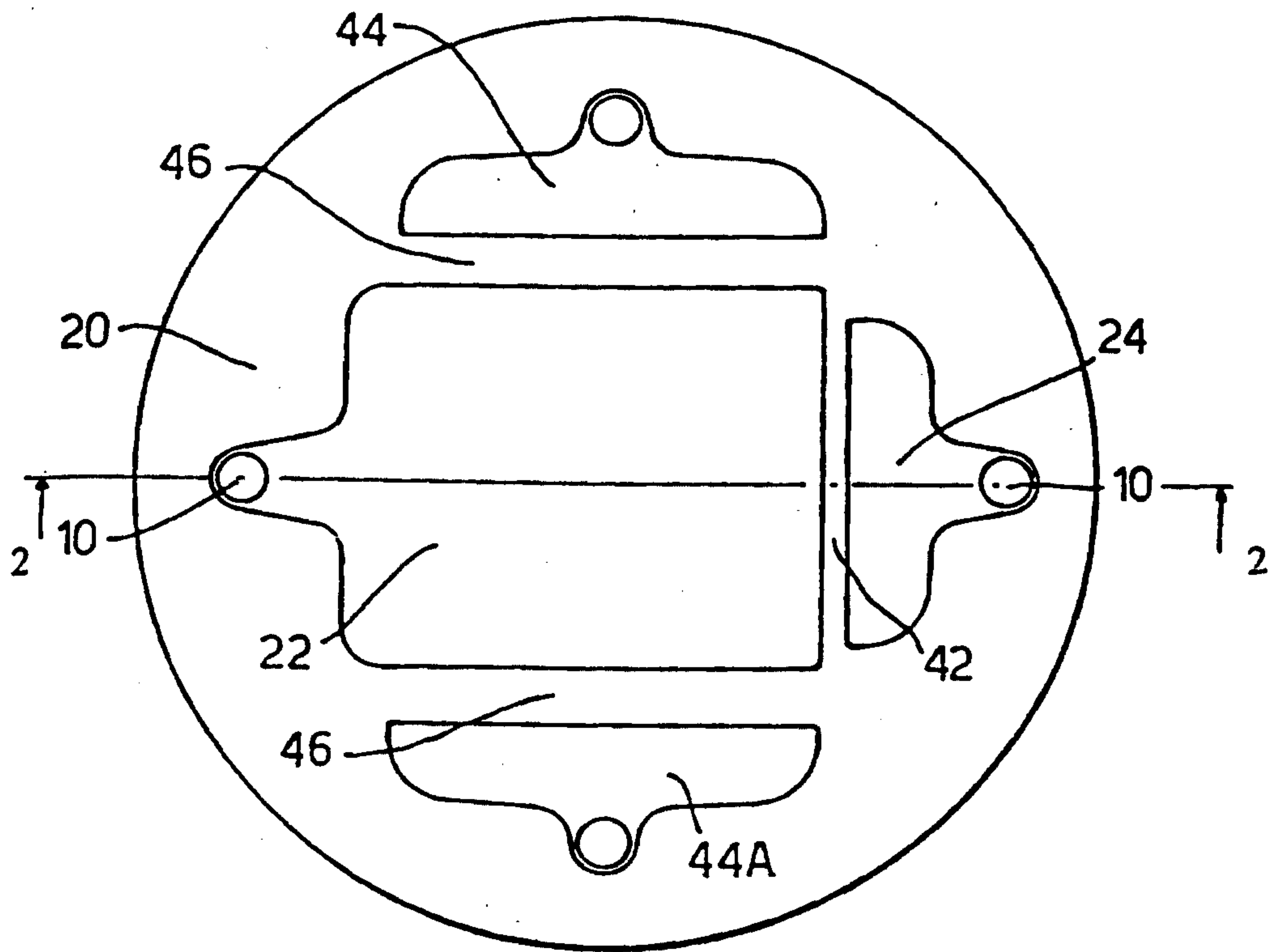

Fig.2A.

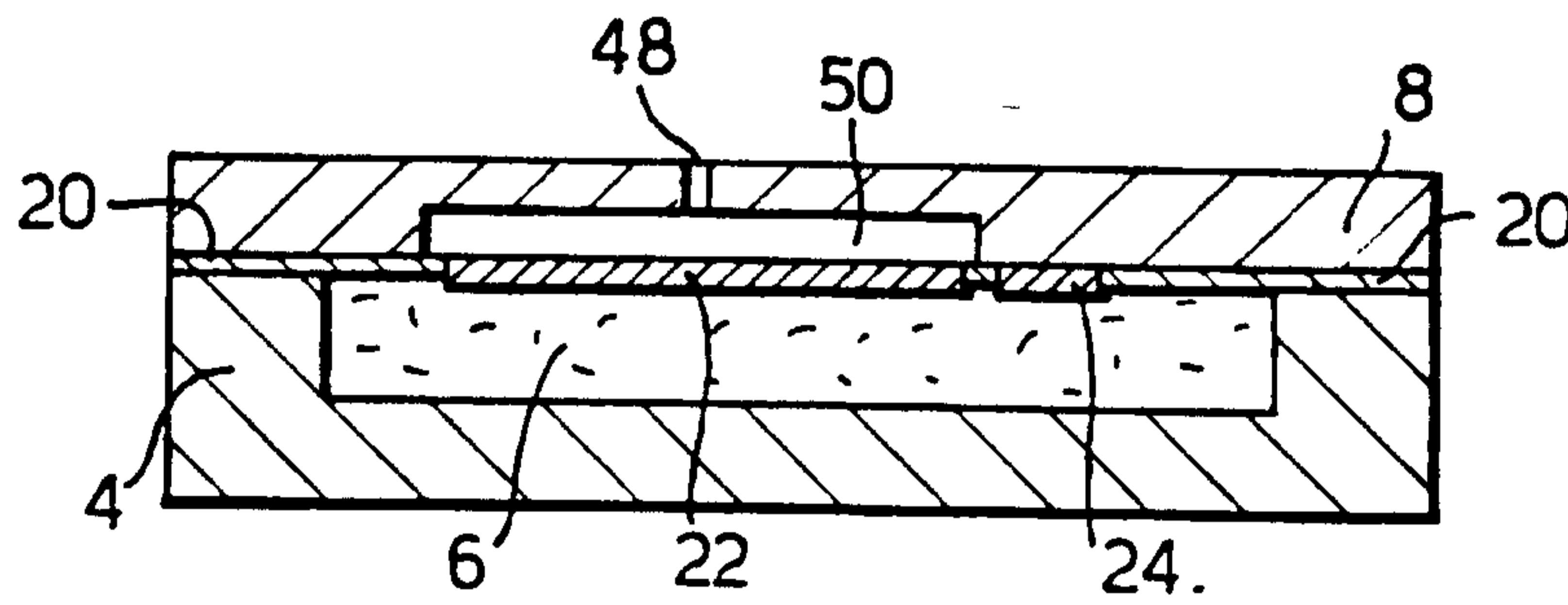

Fig.2B.

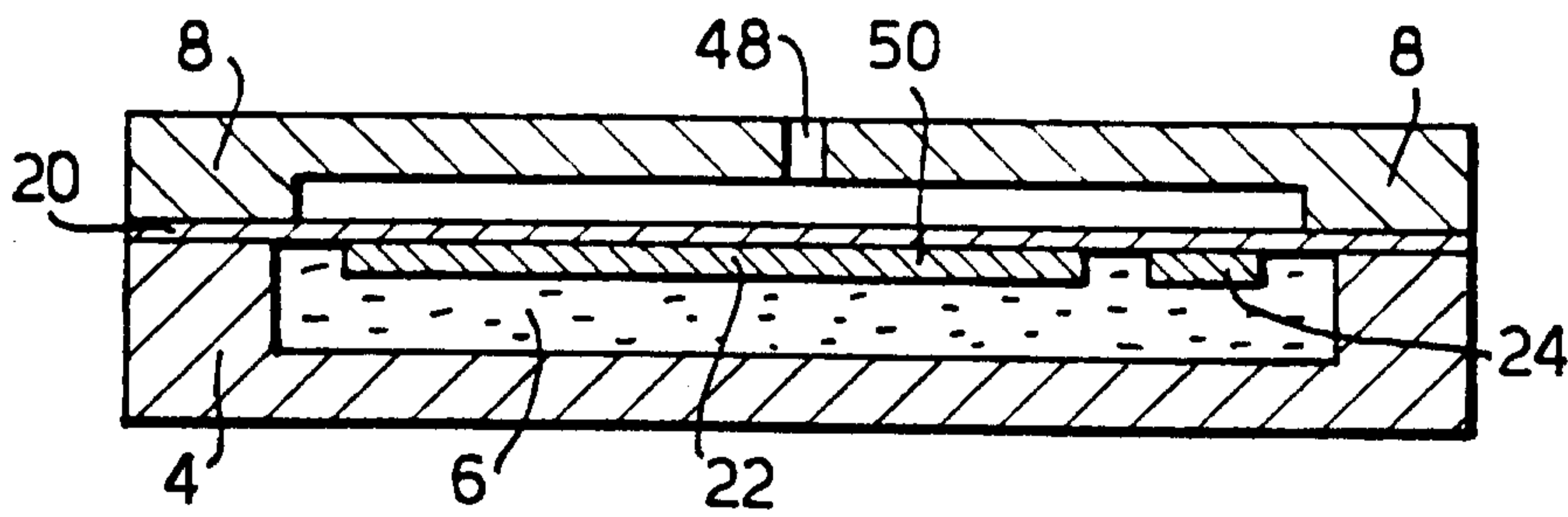

Fig.3.

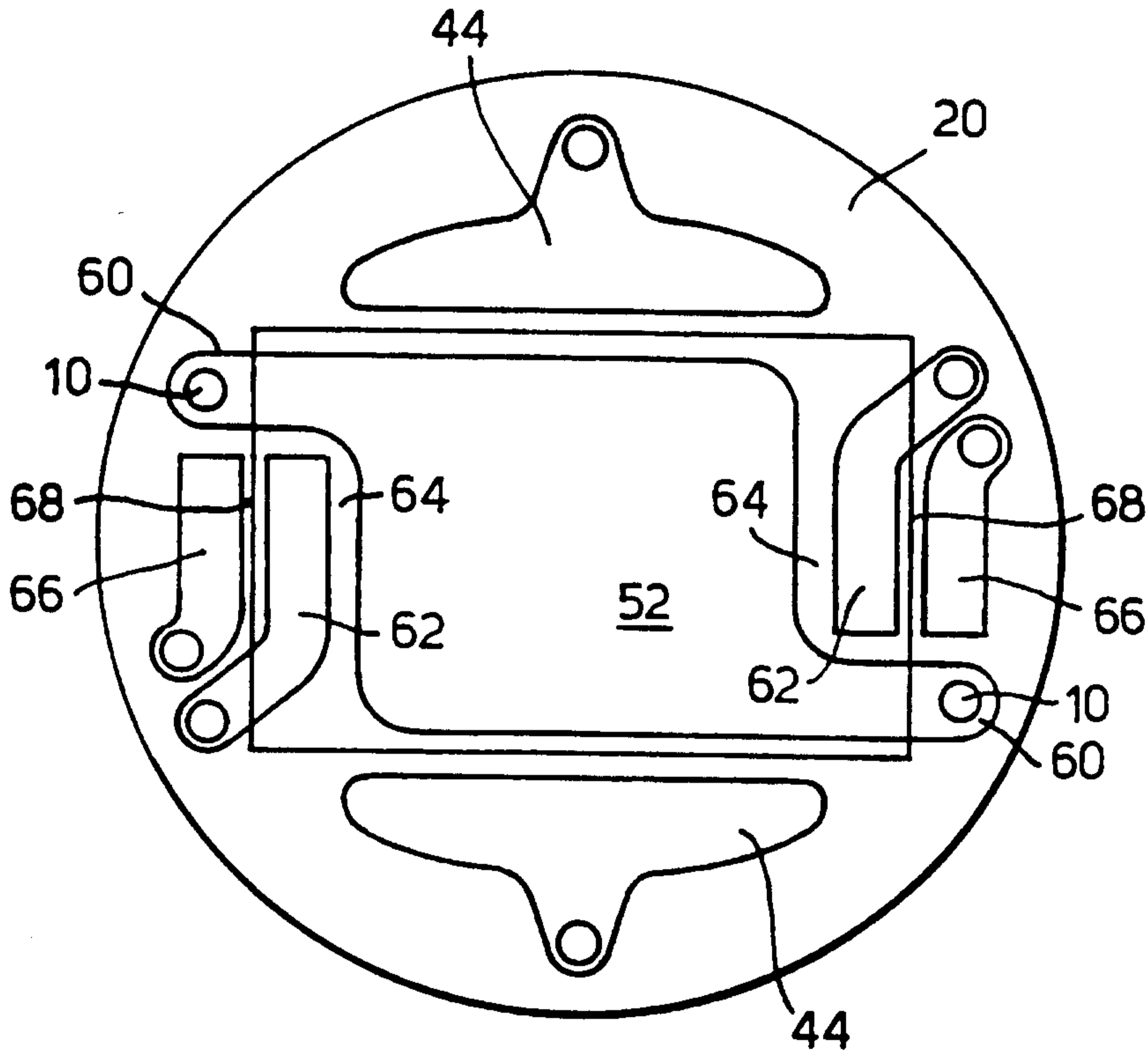

Fig.3A.

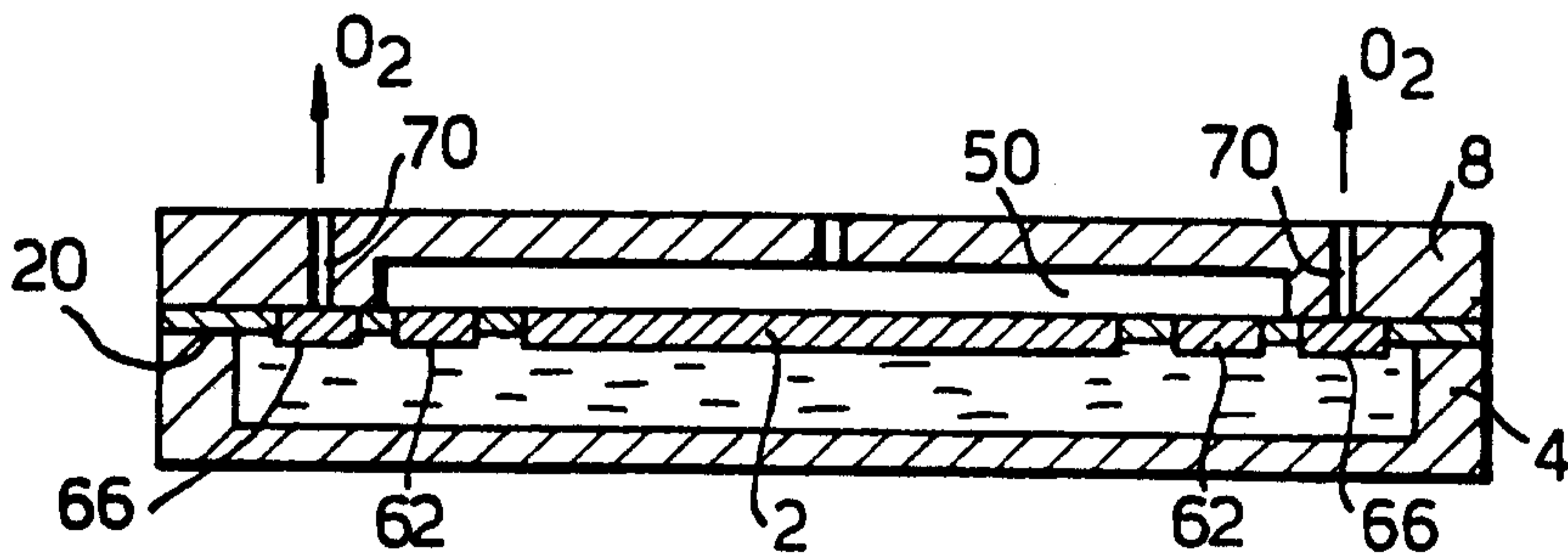

Fig.4.

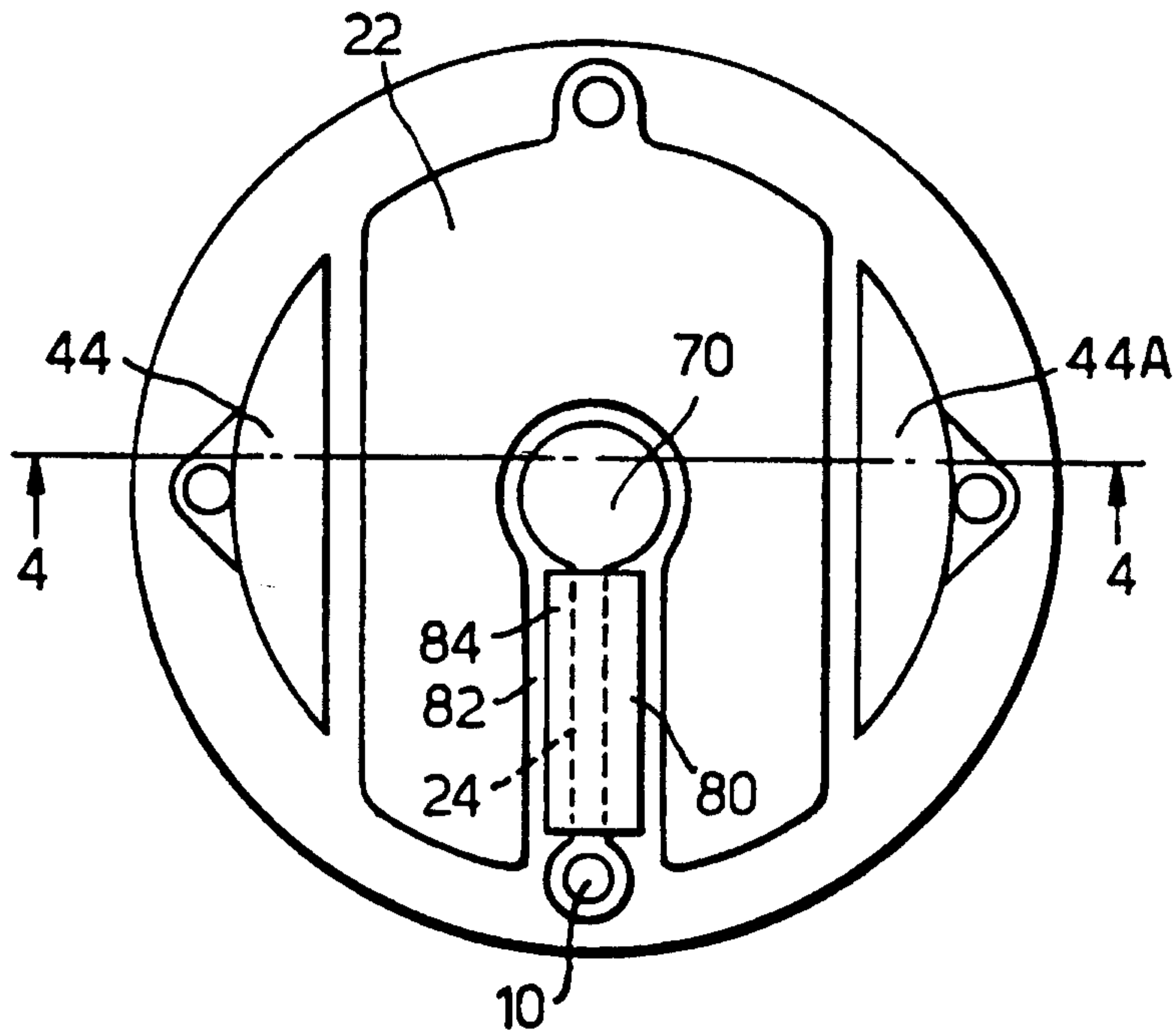

Fig.4A.

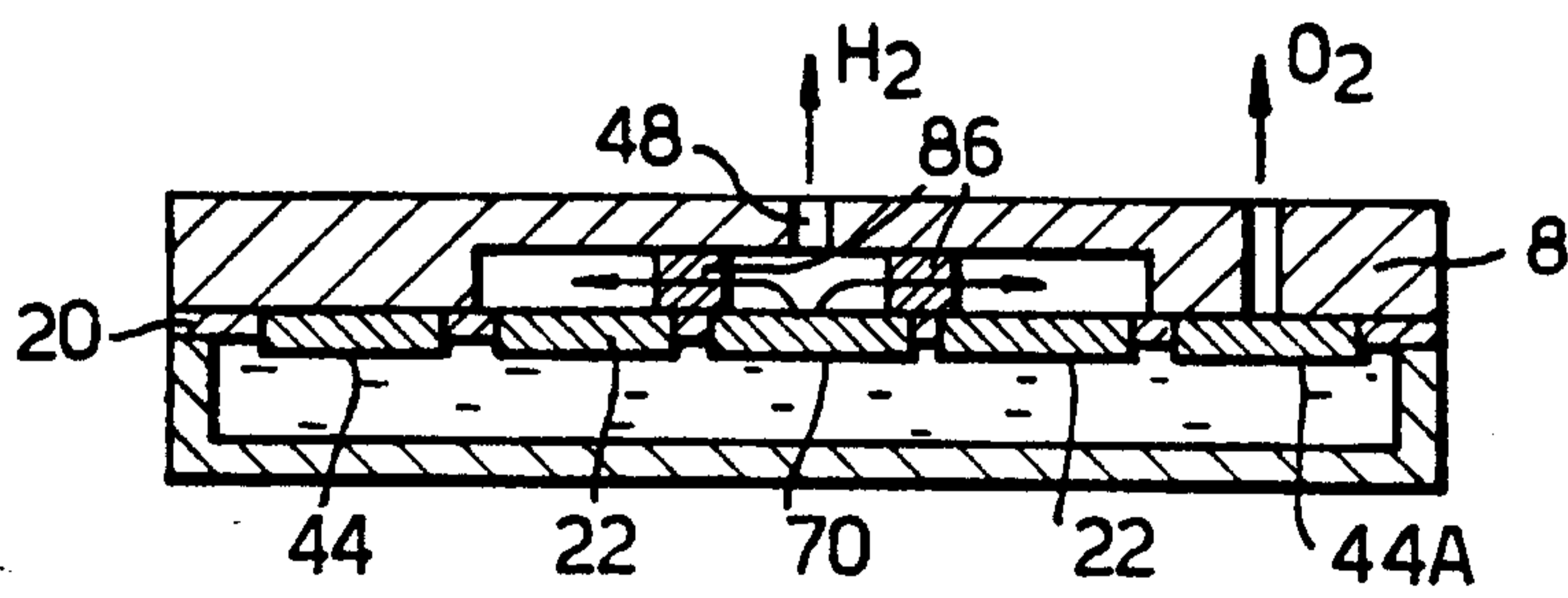

Fig.5.

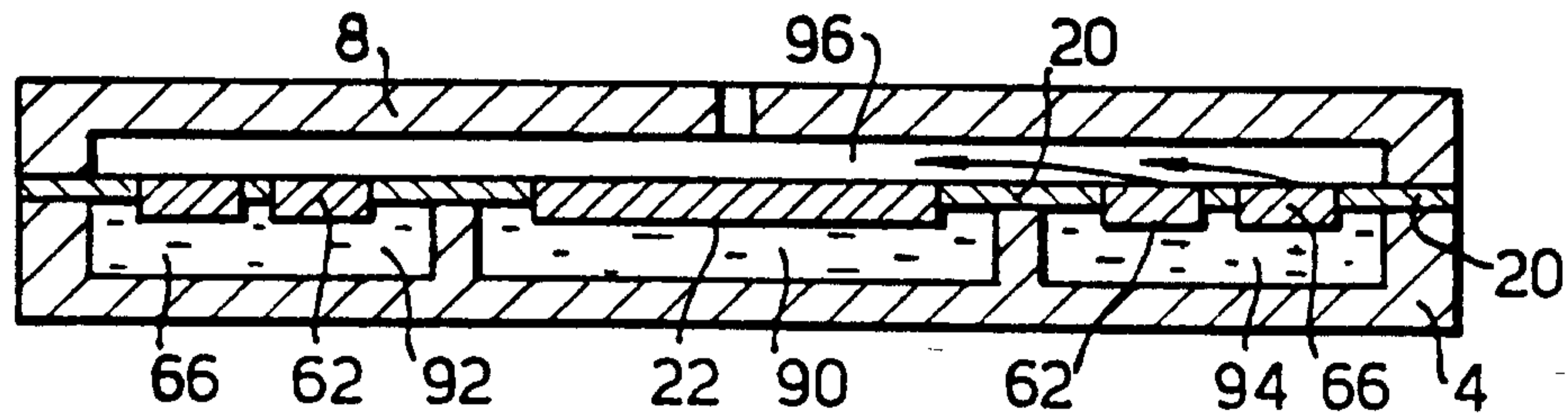

Fig.6A.

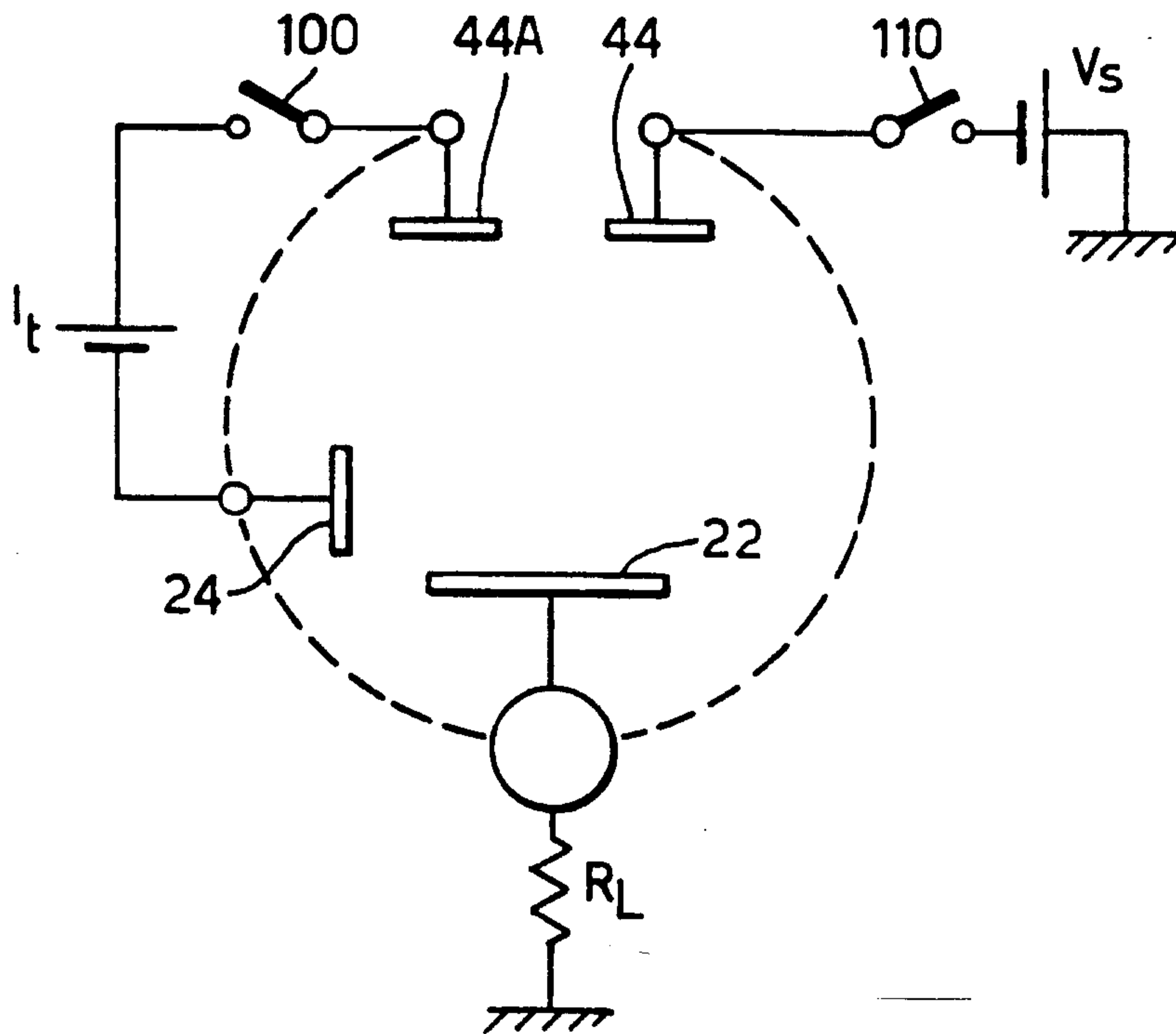

Fig.6B.

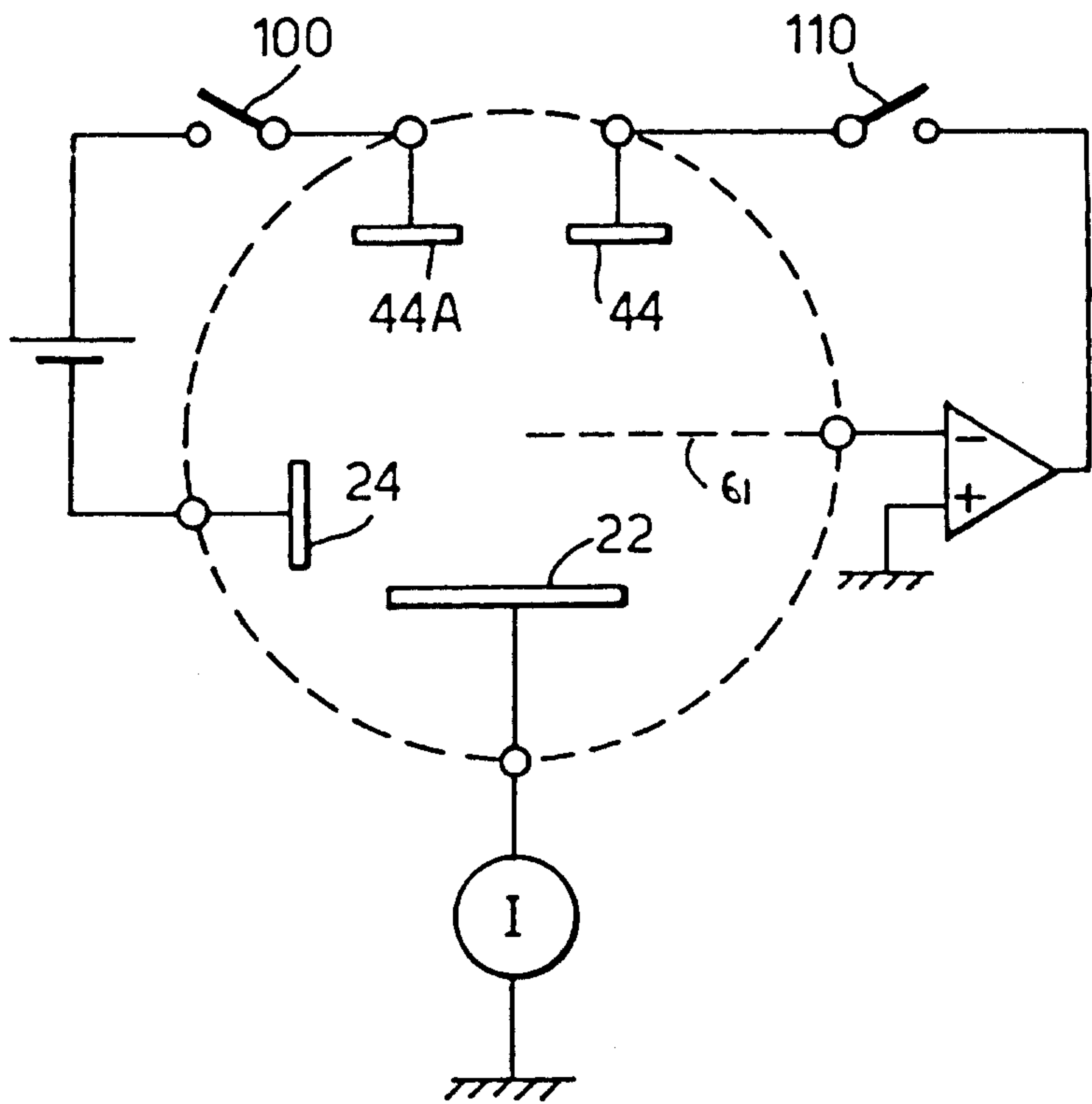

Fig.6C.

