

(19) World Intellectual Property Organization
International Bureau



(43) International Publication Date
26 March 2009 (26.03.2009)

PCT

(10) International Publication Number
WO 2009/037450 A2

(51) International Patent Classification:
G02B 6/44 (2006.01)

(21) International Application Number:
PCT/GB2008/003156

(22) International Filing Date:
17 September 2008 (17.09.2008)

(25) Filing Language: English

(26) Publication Language: English

(30) Priority Data:
0718153.0 17 September 2007 (17.09.2007) GB

(71) Applicant and

(72) Inventor: HAWKINS, David, Frederick [GB/GB]; Unit
2 Heathrow Interchange Park, Bullsbrook Road, Hayes,
Middlesex UB4 0JR (GB).

(74) Agent: HUTCHINS, Michael, Richard; M.R. Hutchins
& Co., 33 Connaught Way, Tunbridge Wells, Kent TN4
9QP (GB).

(81) Designated States (unless otherwise indicated, for every
kind of national protection available): AE, AG, AL, AM,
AO, AT, AU, AZ, BA, BB, BG, BH, BR, BW, BY, BZ, CA,
CH, CN, CO, CR, CU, CZ, DE, DK, DM, DO, DZ, EC, EE,
EG, ES, FI, GB, GD, GE, GH, GM, GT, HN, HR, HU, ID,
IL, IN, IS, JP, KE, KG, KM, KN, KP, KR, KZ, LA, LC, LK,
LR, LS, LT, LU, LY, MA, MD, ME, MG, MK, MN, MW,
MX, MY, MZ, NA, NG, NI, NO, NZ, OM, PG, PH, PL, PT,
RO, RS, RU, SC, SD, SE, SG, SK, SL, SM, ST, SV, SY, TJ,
TM, TN, TR, TT, TZ, UA, UG, US, UZ, VC, VN, ZA, ZM,
ZW.

(84) Designated States (unless otherwise indicated, for every
kind of regional protection available): ARIPO (BW, GH,
GM, KE, LS, MW, MZ, NA, SD, SL, SZ, TZ, UG, ZM,
ZW), Eurasian (AM, AZ, BY, KG, KZ, MD, RU, TJ, TM),
European (AT, BE, BG, CH, CY, CZ, DE, DK, EE, ES, FI,
FR, GB, GR, HR, HU, IE, IS, IT, LT, LU, LV, MC, MT, NL,
NO, PL, PT, RO, SE, SI, SK, TR), OAPI (BF, BJ, CF, CG,
CI, CM, GA, GN, GQ, GW, ML, MR, NE, SN, TD, TG).

Published:
— without international search report and to be republished
upon receipt of that report

(54) Title: A CABLE DUCT RESTRAINING DEVICE

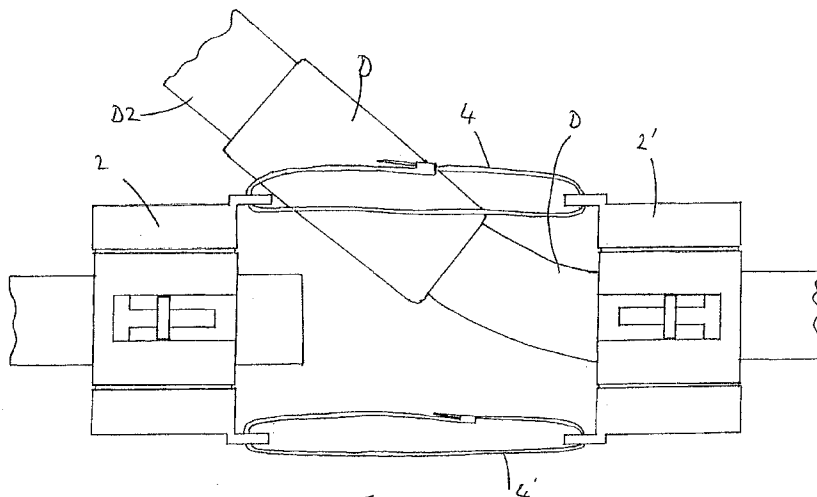

FIG. 2

(57) Abstract: The invention provides a method of forming a connection to a cable duct, which method comprises: (a) clamping about an uncut region of the cable duct a restraining device comprising a linked pair of longitudinally spaced apart restraining elements; (b) cutting the cable duct at a location between the restraining elements; and (c) securing a connector to one or both cut ends of the cut cable duct; wherein each restraining element is configured to grip one of the cut ends so as to restrain the two cut ends against relative longitudinal movement therebetween. Also provided is a restraining device for use in the method of the invention, wherein the restraining device comprises a pair of restraining elements and a linking element for linking the two restraining elements.

WO 2009/037450 A2

A CABLE DUCT RESTRAINING DEVICE

This invention relates to a device for restraining or preventing movement of cut microduct ends in a fibre optics communications line and to a method of preventing migration and loss of cut microduct ends, and the resulting loss of network
5 capacity.

Background of the Invention

A widely used method of creating fibre optic communication lines is to install a bundle of relatively narrow bore ducts commonly known as microducts in a larger bore protective duct or pipe and then install individual optical cables in each
10 microduct. The larger bore protective duct or pipe may be an existing underground pipe or duct or may be a pipe or duct installed for the purpose. A technique used increasingly for installing the individual optical cables into the microducts is the method known as "jetting" or "blowing" in which the cables are driven along the microducts using compressed air.

15 In order to install a branch connection in a fibre optics communications line, a window or break is cut in the outer protective duct and one or more microducts (depending on the number of cables required for the branch connection) in the bundle are cut. The cut ends on the upstream side of the cut are then connected by means of standard connectors to lengths of microduct that branch off to the desired
20 location. Cables can then be blown through the branch microducts without the need for any splicing of the cable.

Whilst effective, this method does have the disadvantage that it leaves a number of loose ends on the downstream side of the cuts in the microducts. It is a common occurrence that the loose ends of the microducts disappear down the protective duct
25 and cannot readily be retrieved or even retrieved at all. This results in the loss of additional cable capacity and also the loss of any future-proofing when upgrades are desirable in populated ducts. Longitudinal movement of the microducts along the protective outer ducts can be caused by a number of factors, for example as a result

temperature variations experienced in the field, by stresses induced during the manufacturing process and also movement caused by land slippage or dig-up.

It will be appreciated that in a fibre optics cable network having a large number of branches, there may be many kilometres of loose and unusable cut microduct within the protective outer ducts giving rise to a substantial loss of capacity. It would therefore be extremely beneficial to be able to secure any unused microduct to prevent the loss of available capacity in the network and thereby preserve the commercial advantages of blown fibre/cables over conventional methods of fibre optics cable installation.

10 **Summary of the Invention**

The present invention provides a solution to the problem of the migration of cut cable duct ends within an outer protective duct by means of a restraining device which is secured to the cable duct either side of the point at which the cable duct is to be cut so that when the cable duct is cut, the two resulting cut ends are held firmly in place and cannot retract into the outer protective duct. One or both cut ends may then be used to form a connection with another length of cable duct, for example to form a branch connection.

Accordingly, in a first aspect, the invention provides a method of forming a connection to a cable duct, which method comprises:

- 20 (a) clamping about an uncut region of the cable duct a restraining device comprising a linked pair of longitudinally spaced apart restraining elements;
- (b) cutting the cable duct at a location between the restraining elements;
- and
- (c) securing a connector to one or both cut ends of the cut cable duct;
- 25 wherein each restraining element is configured to grip one of the cut ends so as to restrain the two cut ends against relative longitudinal movement therebetween.

The cable duct is preferably a cable duct of the type used to carry fibre optics communications cables and is typically installed in a protective outer duct. Each protective outer duct will typically be capable of carrying a plurality, e.g. four or

more) cable ducts depending upon the size of the cable ducts. The cable ducts may, for example, range in size from about 3 mm to about 16 mm in external diameter (O.D.), more usually from 5 mm to 12 mm in external diameter. Such ducts are often referred to as micro-ducts and the term "micro-ducts may be used herein for
5 convenience as a synonym for cable ducts.

The restraining device is clamped to the cable duct either side of the cut and the two restraining elements are each firmly clamped to one cut end. Because the two restraining elements are linked together, the two cut ends of the cable duct are held firmly in position and relative longitudinal movement between them is prevented.
10 A connector may therefore be connected to one cut end and another length of cable duct may be attached to the connector (for example to form a branch connection) without concern that the other cut end will retract back along the outer protective duct.

The two restraining elements are linked together by means of a suitable linking element which may be, for example a flexible element. The flexible element may take the form of a strap (e.g. a cable tie) or chain. There may be one linking element or more than one linking element, for example two linking elements. The length of the or each linking element will be such as to permit access to the region of the cable duct between the restraining elements so as to allow manipulations
15 such as cutting the duct and attaching connectors to one or both cut ends to take place.
20

Each restraining element is configured so that it can be positioned (e.g. wrapped) about the uncut cable duct without the need for an end of the uncut microduct to be threaded through the body. This may be accomplished, for example, by forming
25 each restraining element from a plurality of members that may be separated to enable them to be positioned about the cable duct and then reconnected to surround the cable duct. The plurality of members can be separated by partially or completely detaching one from the other. For example, one member may be hingedly connected to another, the hinge being opened so that the members can be

positioned about the cable duct and then closed to clamp the restraining device against the cable duct.

In another aspect, there is provided a restraining device for use in the method of the invention, the restraining device comprising a pair of restraining elements and a
5 linking element for linking the two restraining elements.

In one embodiment, a restraining element forming part of the restraining device of the invention comprises (i) at least one clamping member; (ii) at least one gripping member for gripping the cable duct, the gripping member being disposed radially inwardly of the clamping member, and (iii) means for urging the clamping member
10 against the gripping member so as to compress the gripping member against the cable duct.

For example, each restraining element may comprise a pair of clamping members, each clamping member having an associated gripping member, and means for drawing the clamping members together to urge them against the gripping
15 members.

Each clamping member may have a longitudinally aligned tapering flange on one, and optionally both, sides thereof, and the means for drawing the clamping members together may take the form of a sliding cap that has a pair of convergent grooves for receiving a tapering flange of each of the clamping members, whereby
20 sliding the cap along the tapering flanges draws the two tapering flanges together and hence brings the clamping members together.

Preferably, the means for drawing the clamping members together comprises two sliding caps, each having a pair of convergent grooves for receiving the tapering flanges of the clamping members.

25 The linking elements may be connected to the sliding caps. In this way, a force exerted on one restraining member in a direction away from the other restraining member may result in the cap being pulled further onto the flanges thereby further tightening the clamping member against its associated gripping member.

The gripping member may exert its grip on the cable duct by means of frictional engagement, or it may have a roughened surface or have a gripping edge(s) or protrusion(s) such as a ridge(s) or teeth to grip the cable duct as the gripping member is forced against the cable duct when the clamping member is tightened.

- 5 The gripping member may be provided with a single gripping edge or protrusion or single row of gripping teeth or may be provided with a plurality of gripping edges or protrusions or a plurality of rows of teeth or any combination thereof. In one particular embodiment the, the gripping member exerts its grip by means of a gripping edge at one end thereof.
- 10 Each gripping member may be of channel section, and preferably a part elliptical or part circular channel section so as to fit about the cable duct. The depth of the channel section preferably tapers in a longitudinal direction. The gripping members are preferably slidable in a longitudinal direction with respect to the clamping members such that sliding them in one direction brings them into tighter frictional
- 15 the engagement with the cable duct and sliding them in the reverse direction loosens the engagement with the cable duct. The radially inner surface of the channel section may be provided with one or more ridges, protrusions or teeth that serve to bite into and grip the cable duct when the gripping members are clamped down onto the cable duct.
- 20 The two gripping members may together constitute a split collet.

The gripping members may be separate discrete elements or they may be flexibly linked together, e.g. hingedly linked together. In one embodiment, they are separate entities. In another embodiment, they are linked (e.g. hingedly linked).

- 25 The restraining devices of the invention may be used at any microduct manipulation point. Thus, for example, they may be used to tether microducts in manholes, handholes, exchanges, points of entry into buildings, nodes and branch points on communications networks, cabinets, and other forms of enclosure containing microduct assemblies. Thus the restraining devices are transportable and are usable at a wide range of different locations on a network.

In another aspect, the invention provides an enclosure for surrounding a fibre optics cable, the enclosure containing a restraining device as defined herein.

The enclosure may take the form of a casing having an opening at an end (and typically both ends) thereof for receiving an end of a protective outer duct. The
5 connection to the protective outer duct may be an unsealed or a sealed connection.

The casing may be provided with one or more further openings for receiving one or more protective outer ducts of a branched cable.

The casing may comprise a plurality (e.g. a pair) of casing members configured to be secured together about the microducts. The casing members may be secured to
10 together by any suitable fastening means, for example by screws, bolts, ties, bands or like fastenings or by means of a snap fit. In one embodiment, the casing members are secured together by means of split caps at either end thereof, wherein the split caps are each configured to surround an end of a protective outer duct.

Further aspects of the invention will be apparent from the specific description
15 below and the drawings appended hereto.

Brief Description of the Drawings

Figure 1 is a side view of a restraining device secured to a cable duct according to one embodiment of the invention.

Figure 2 is a side view of the restraining device showing the cable duct after the
20 insertion of a branch connection.

Figure 3 is a perspective view of one of the pair of restraining elements of the restraining device shown in Figure 1.

Figure 4 is a side view of the restraining element of Figure 3.

Figure 5 is an end view of the restraining element of Figure 3.

25 Figure 6 is an opposite end view of the restraining element of Figure 3.

Figure 7 is a plan view from direction D3 of the restraining element of Figure 2.

Figure 8 is a plan view of the restraining element of Figure 3 with the sliding top member removed.

Figure 9 is a view from below of the sliding top member.

5 Figure 10 is an end view of the sliding top member of Figure 7.

Detailed Description of the Invention

The invention will now be illustrated in greater detail, but not limited, by reference to the specific embodiments illustrated in the drawings.

10 Figure 1 illustrates a restraining device according to one embodiment of the invention. The device comprises a pair of restraining elements 2 and 2' mounted on a length of micro-duct D and linked by means of flexible connecting straps 4 and 4'. The connecting straps can be for example short lengths of chain or cable ties. In the embodiment illustrated, the connecting straps are cable ties.

15 The restraining elements are assembled about the micro-duct as described below prior to cutting the micro-duct to form a branch connection. After cutting, one of the two cut ends is connected to a connector C which can be of standard type and need not be described in detail here. The connector in turn may be connected to a further length of micro-duct D2 to form a branch connection.

20 In the absence of the restraining device of the invention, it has been found that when a micro-duct is cut for the purposes of inserting a branch connection, the free cut end, i.e. the cut end that is not secured to the branch connector, will often migrate back along the outer protective duct with result that it is no longer accessible and cannot thereafter be used. The migration back along the outer protective duct may be due to any of a number of factors. For example, the micro-
25 duct may have been installed in the outer protective duct under tension such that once it is cut, and the tension is released, the free end of the micro-duct retracts back along the protective duct. By using the restraining device of the invention,

migration of the free end of the cut micro-duct back along the outer duct is prevented.

The construction of the individual restraining elements 2 and 2' is illustrated in more detail in Figures 3 to 9.

5 As shown, each restraining element comprises a pair of clamping members 10 and 12, a pair of sliding cap members 14 and 16, and a pair of gripping members 18 and 20. Each clamping member has a pair of tapering flanges 22 that are aligned in a longitudinal direction and are generally parallel to each other. The tapering flanges are undercut by a groove 24. Sliding cap members 14 and 16 fit over the flanges
10 22, the grooves 26 in the cap members accommodating the flanges 22 and the inwardly oriented portions 28 slotting into the undercut groove 24. As the sliding cap members 14 and 16 are pushed onto the flanges 22, the inclined walls 30 of the groove in the sliding cap engage the inclined edges of the tapering flanges 22 and force the two clamping members 10 together. As the clamping members 10 are
15 forced together, the force is transmitted to the gripping members 18 and 20 which are compressed against the micro-duct D.

The restraining elements are used in pairs and are connected together as shown in Figures 1 and 2. In order to enable them to be connected together, each restraining element has a tab 44 in which there is a hole 46 through which a linking element
20 such as a cable tie can be inserted. In use, the two restraining elements are connected about the micro-duct so that the tabs 44 of each element are facing one another.

In the side of each clamping member 10 is a rectangular recess 34 within which is formed a T-shaped slot 36. The T-shaped slot 36 and recess 34 together form a
25 track along which a rectangular headed lug 38 can slide. The rectangular headed lug 38 is attached to a gripping member and the rectangular head provides a means of moving the gripping member to and fro in a longitudinal direction. The gripping member is of channel section, the channel being arcuate in cross section. The inner surface of the channel is inclined relative to the outer surface 42 of the gripping
30 member, the direction of the inclination of the inner surface being radially inwardly

in the direction of the tab 44. At the narrower end 40, a radially inwardly oriented sharp-edged ridge extends around the inner circumference of the channel which serves to bite into the surface of the cable duct and thereby enhance the grip as the gripping member is clamped down onto the cable duct. When the restraining device has been fitted about the micro-duct D, the tightness of the gripping member against the micro-duct D can be increased or decreased by using the rectangular headed lug 38 to slide the gripping member in a direction away from tab 44. The grip on the micro-duct can be loosened by sliding the gripping element in the opposite direction.

10 Because of the inclined surface of the gripping element, any attempt to pull the cut end of the micro-duct rearwardly out of the restraining device results in the sharp edged ridge of the gripping element being forced into tighter engagement with the surface of the micro-duct thereby increasing its grip on the micro-duct.

The components of the restraining element are typically formed from plastics materials and may be manufactured by injection moulding in standard fashion.

Equivalents

It will readily be apparent that numerous modifications and alterations may be made to the specific embodiments of the invention described above without departing from the principles underlying the invention. All such modifications and alterations are intended to be embraced by this application.

CLAIMS

1. A method of forming a connection to a cable duct, which method comprises:
 - (a) clamping about an uncut region of the cable duct a restraining device comprising a linked pair of longitudinally spaced apart restraining elements;
 - (b) cutting the cable duct at a location between the restraining elements; and
 - (c) securing a connector to one or both cut ends of the cut cable duct;
- 10 wherein each restraining element is configured to grip one of the cut ends so as to restrain the two cut ends against relative longitudinal movement therebetween.
2. A method according to claim 2 wherein the cable duct is a cable duct of the type used to carry fibre optics communications cables and is installed in a protective outer duct.
- 15
3. A method according to claim 1 or claim 2 wherein each restraining element is formed from a plurality of members that may be separated to enable them to be positioned about the cable duct and then reconnected to surround the cable duct.
- 20 4. A restraining device for use in the method of the invention, the restraining device comprising a pair of restraining elements and a linking element for linking the two restraining elements.
5. A restraining device according to claim 4 wherein each restraining element comprises (i) at least one clamping member; (ii) at least one gripping member for gripping the cable duct, the gripping member being disposed radially inwardly of the clamping member, and (iii) means for urging the clamping member against the gripping member so as to compress the gripping member against the cable duct.
- 25

6. A restraining device according to claim 5 wherein each restraining element comprises a pair of clamping members, each clamping member having an associated gripping member, and means for drawing the clamping members together to urge them against the gripping members.
- 5 7. A restraining device according to claim 6 wherein each clamping member may has a longitudinally aligned tapering flange on one, and optionally both, sides thereof, and the means for drawing the clamping members together takes the form of a sliding cap that has a pair of convergent grooves for receiving a tapering flange of each of the clamping members, whereby
10 sliding the cap along the tapering flanges draws the two tapering flanges together and hence brings the clamping members together.
8. A restraining device according to claim 7 wherein the means for drawing the clamping members together comprises two sliding caps, each having a pair of convergent grooves for receiving the tapering flanges of the clamping
15 members.
9. A restraining device according to claim 7 and any claim dependent thereon, wherein each gripping member is of a part elliptical or part circular channel section so as to fit about the cable duct.
10. A restraining device according to claim 9 wherein the depth of the channel
20 section tapers in a longitudinal direction.
11. A restraining device according to claim 10 wherein the gripping members are slidable in a longitudinal direction with respect to the clamping members such that sliding them in one direction brings them into tighter engagement with the cable duct and sliding them in the reverse direction loosens the
25 engagement with the cable duct.
12. A restraining device according to claim 7 and any claim dependent thereon wherein the gripping members are separate discrete elements.

13. A restraining device according to any one of claims 5 to 12 wherein at least one gripping member is provided with one or more ribs, ridges, teeth or other protrusions for gripping the surface of the cable duct.
14. A restraining device according to claim 13 wherein each gripping member is provided with one or more ribs, ridges, teeth or other protrusions for gripping the surface of the cable duct.
15. A restraining device according to claim 13 or claim 14 wherein one or each gripping member is provided with a circumferentially extending sharp edged ridge for gripping the cable duct.
16. A restraining element as defined in any one of claims 5 to 15.
17. A restraining device substantially as described herein with reference to the accompanying drawings.
18. A restraining element substantially as described herein with reference to the accompanying drawings.

1/6

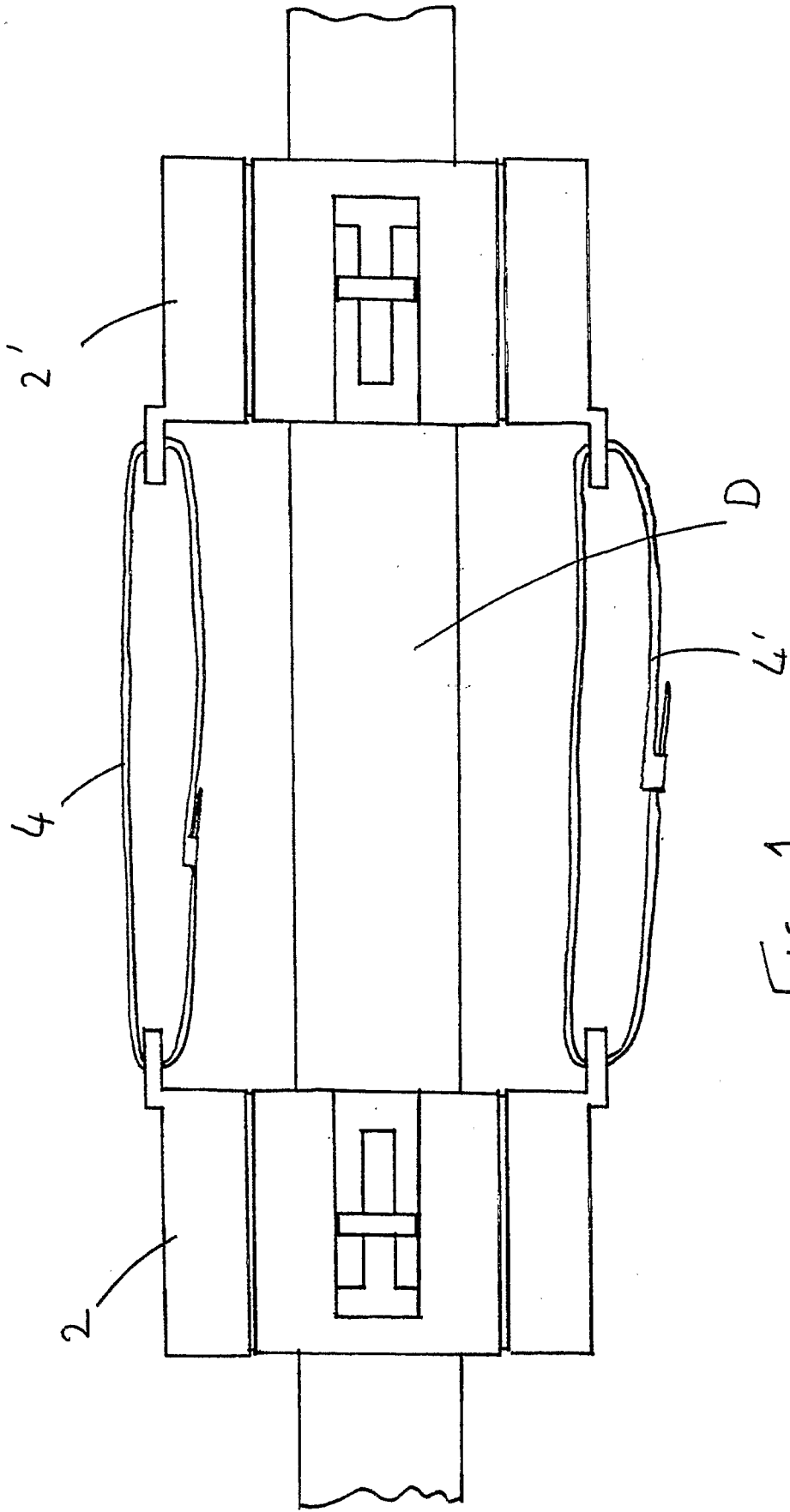

FIG. 1

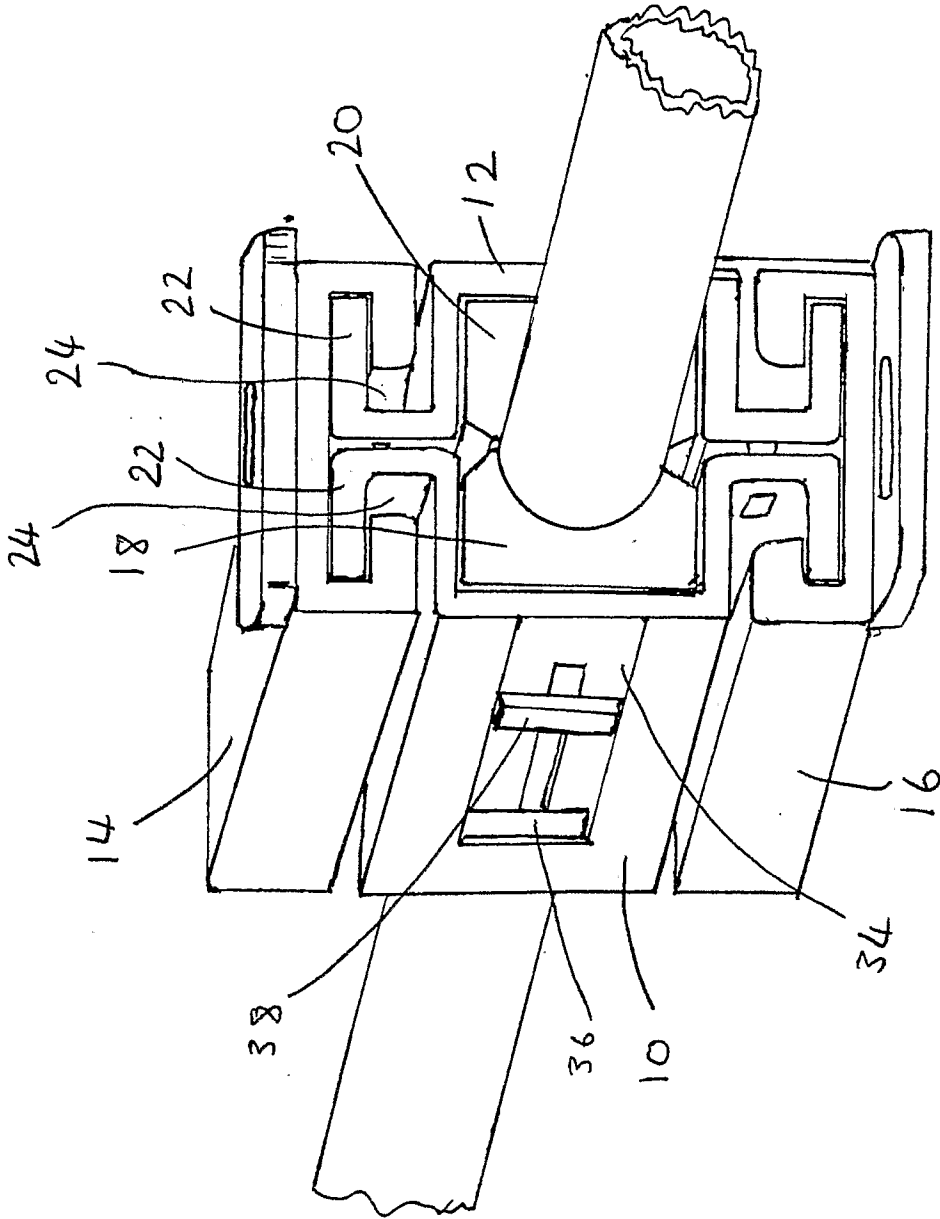

FIG 3

4/6

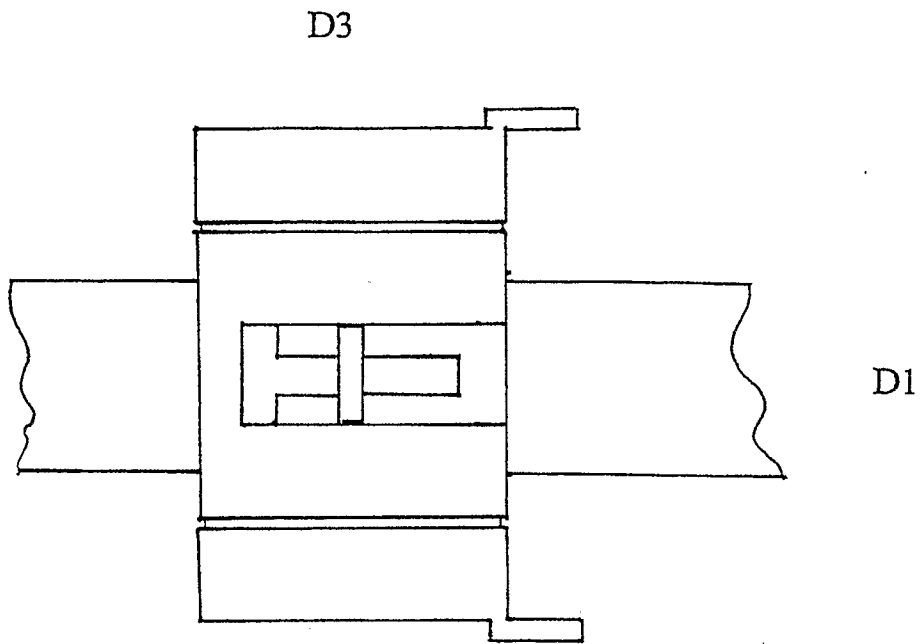

Figure 4

5/6

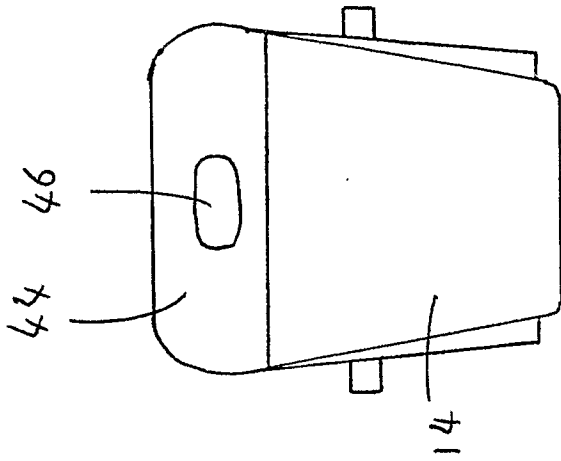

Figure 7

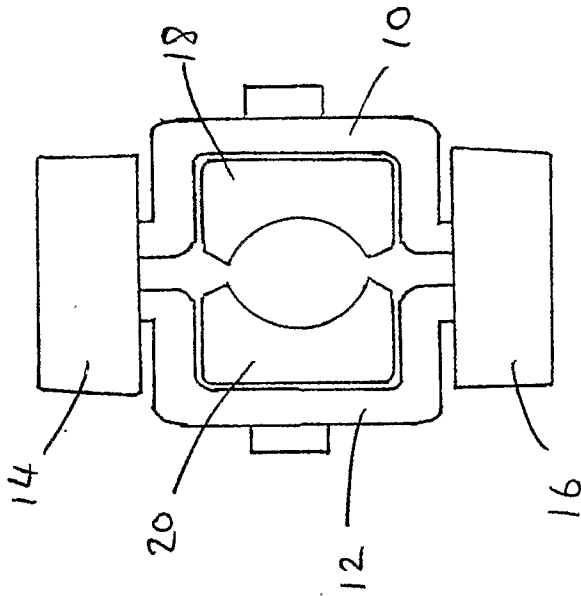

Figure 6

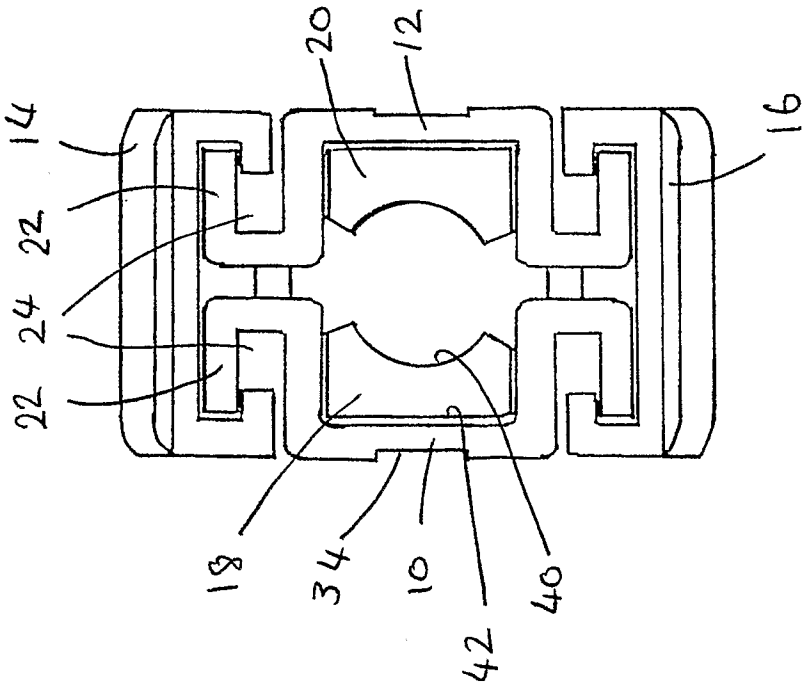

Figure 5

6/6

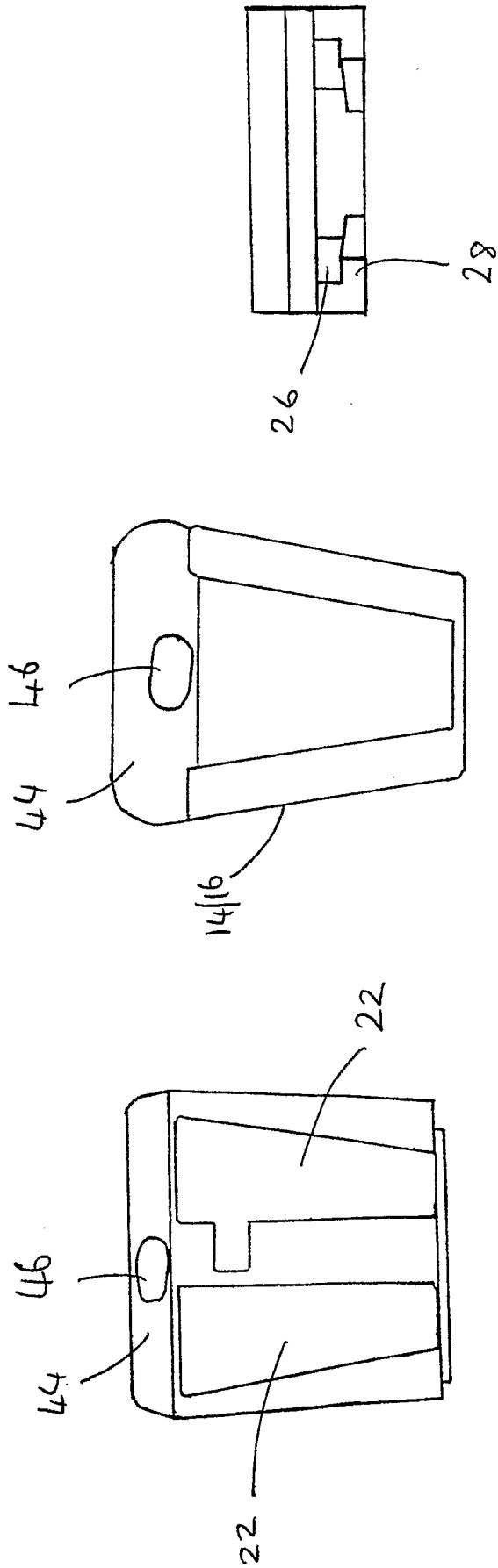

Figure 10

Figure 9

Figure 8