

N. S. REEDER.  
 CAR DUMPING MECHANISM.  
 APPLICATION FILED JULY 22, 1910.

998,393.

Patented July 18, 1911.

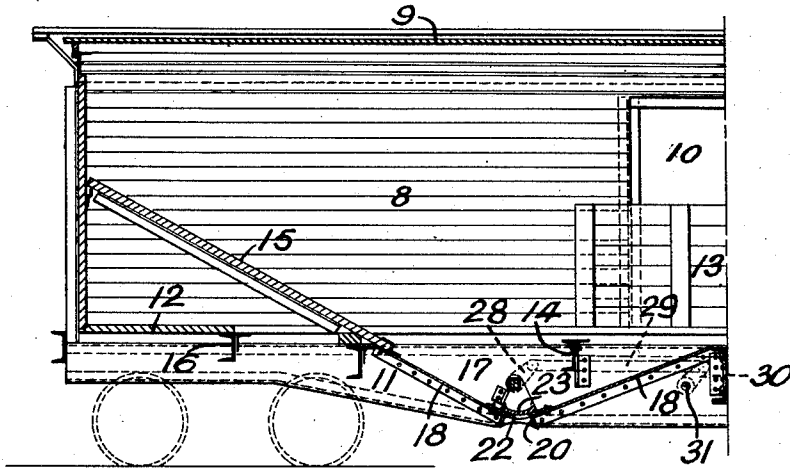

FIG. 1.

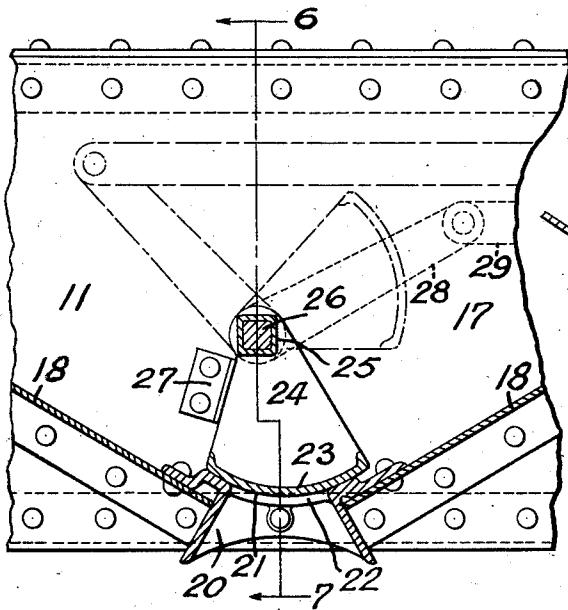

FIG. 2.

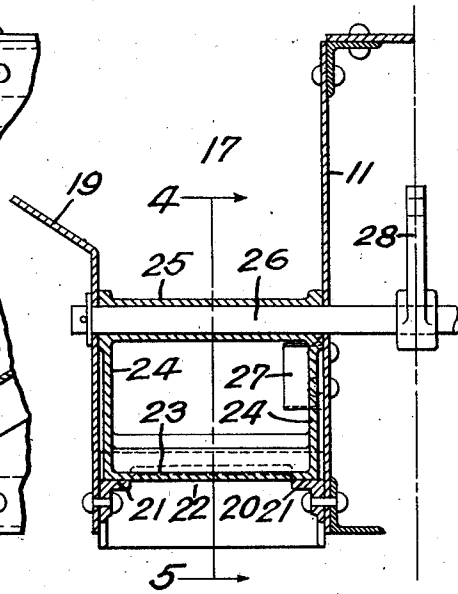

FIG. 3.

WITNESSES  
*Shanklin*  
*E. R. M. Hensie*

INVENTOR  
 NATHANIEL S. REEDER.  
 By *Frank S. ... atty.*

# UNITED STATES PATENT OFFICE.

NATHANIEL S. REEDER, OF CHICAGO, ILLINOIS.

CAR-DUMPING MECHANISM.

998,393.

Specification of Letters Patent. Patented July 18, 1911.

Application filed July 22, 1910. Serial No. 573,359.

To all whom it may concern:

Be it known that I, NATHANIEL S. REEDER, of the city of Chicago, in the State of Illinois, United States of America, have invented certain new and useful Improvements in Car-Dumping Mechanism, of which the following is a full, clear, and exact description.

This invention relates to improvements in grain cars and the objects are to provide a gate for controlling the discharge of grain from a hopper bottom car which may be quickly and easily opened or closed, and which will absolutely prevent any leakage of grain in transit. To accomplish these objects, I provide a suitable jamb plate at the mouth of each hopper of a car. An eccentrically pivoted gate is arranged to open or close the hopper, and, by means of its eccentric mounting, wedges itself against the jamb plate in closing to prevent any grain leakage.

In the drawings which illustrate my invention:—Figure 1 is a half vertical longitudinal section of a car equipped with my gate. Fig. 2 is an enlarged view on the line 4—5 of Fig. 3, showing the gate in detail. Fig. 3 is a vertical cross section on the line 6—7 of Fig. 2.

In the above defined figures, 8 designates the box or body of a car which is preferably made with the boards placed longitudinally inside the framework so as to present a perfectly smooth interior surface. This body is provided with a roof 9 and doorways 10. The body is mounted on longitudinal center sills 11. At each end of the car, the portion 12 of floor over the truck is stationary. The floor in the center of the car is formed of a pair of doors 13 which divide longitudinally at the center of the car and are hinged at the sides of the car. These doors 13 extend well beyond the sides of the doorways and are supported at their ends on the transverse or cross bearers 14. The floor at each end of the doors 13, between said doors and the stationary floors 12 is formed in a single intermediate section 15 extending the full width of the car. These intermediate sections 15 are supported at their inner ends on the same transom 14 which supports the ends of the doors, and are supported at their outer ends on other transoms 16, which latter transoms also support the inner ends of the stationary floor sections 12.

Below the floor a plurality of stationary

hoppers 17 are located on each side of the center sills.\* These hoppers are each composed of a pair of plates 18 sloping downwardly between the transoms. The inner sides of the hoppers are formed by the webs of the center sills and the outer sides are formed by plates 19 sloping downwardly from the sides of the car, toward the center sills. At the bottom of each hopper the various plates forming the same are connected to a suitable apertured jamb plate 20, which forms the mouth of the hopper. The plate 20 is preferably a casting and is provided with a curved seat 21, which surrounds the mouth aperture 22. A gate or valve primarily in the form of a plate 23 curved to fit the seat 21, is mounted within each hopper. The plate 23 is provided with a pair of substantially triangular end members 24 connected at their apices by a tubular portion 25. A shaft 26 extends transversely of the car through the lower portion of each pair of hoppers and carries the gate.

The tubular portion 25 of the gate surrounding the shaft is located eccentrically with respect to the curvature of the plate 23, so that when the gate is closed, the plate 23 will be wedged against the seat 21. The tube 25 and the portion of the shaft 26 lying therein, are both preferably square in order that the gate may be fixed to the shaft so as to revolve therewith. A stop 27 is attached to the center sill to prevent the gate being closed so tightly as to be difficult to open. Between the center sills, an operating lever 28 is fixed at one end to the shaft 26 and at the opposite end to a rod 29. This rod may connect the operating levers of all gates on a single car so as to operate all simultaneously, or may be arranged to operate only one pair of hoppers, as shown in Fig. 1. The rod 29 is connected by a crank 30 to a shaft 31 lying transversely under the car.

In operation as a grain car, the two floor doors 13 are raised to form an inner covering for the doorways 10, and the intermediate floor sections 15 are disposed as shown in Fig. 1, so that there is no level floor on which grain will lodge. The car is filled in the usual way and despatched to its destination. To empty the car the operator imparts a longitudinal movement to the rod 29 so as to shift the lever 28 and raise the gates to the position shown in dotted and dashed lines in Fig. 2. When the car is empty, or

sufficient grain has escaped, the rod 29 is moved in the reverse direction so that the gate returns to its original position. It will be readily seen from Fig. 2, that the gate in closing will be wedged on its seat, thus  
 5 either displacing or crushing any grain that would tend to obstruct the closing, or block the gate open sufficiently to allow grain to leak out. It will also be seen that,  
 10 whether in opening or closing, all portions of the gate move edgewise through the grain so that practically no resistance is offered to the movement. The gates may, obviously, be operated in any combination de-  
 15 sired, and by any suitable mechanism other than that disclosed, without departing from the spirit of the invention.

Having thus described my invention, what I claim is:—

20 1. A device of the class described comprising the combination with the hopper of a car, of an apertured mouth plate at the lowest point of said hopper, a curved closure plate, integral side members therefor  
 25 pivoting the closure plate eccentrically with

respect to the mouth plate, a shaft supporting the closure plate, a lever fixed to said shaft, an operating shaft, a lever thereon, and a link connecting said levers for rotating said supporting shaft to wedge the closure plate over the aperture of the mouth plate. 30

2. A device of the class described comprising the combination with the hopper of a car, of an apertured mouth plate at the  
 35 lowest point of said hopper having a curved upper surface, a gate within the hopper eccentrically pivoted with respect to the mouth plate, having a curved closure plate adapted to be wedged against the mouth  
 40 plate, side plates carrying the closure plate, an integral hub connecting said side plates, a shaft for operating said gate, and a stop for the gate.

In witness whereof I have hereunto set  
 my hand in the presence of two witnesses. 45

NATHANIEL S. REEDER.

Witnesses:

HARRY S. HAMMOND,  
 ARCHIBALD HAZLEHURST.