



INTERNATIONAL APPLICATION PUBLISHED UNDER THE PATENT COOPERATION TREATY (PCT)

<p>(51) International Patent Classification ⁷ : B05B 11/00, B65D 5/04</p>	<p>A1</p>	<p>(11) International Publication Number: WO 00/54891</p> <p>(43) International Publication Date: 21 September 2000 (21.09.00)</p>
<p>(21) International Application Number: PCT/GB00/00944</p> <p>(22) International Filing Date: 17 March 2000 (17.03.00)</p> <p>(30) Priority Data: 9906064.2 18 March 1999 (18.03.99) GB</p> <p>(71) Applicant (for all designated States except US): RECKITT & COLMAN PRODUCTS LIMITED [GB/GB]; One Burlington Lane, London W4 2RW (GB).</p> <p>(72) Inventors; and (75) Inventors/Applicants (for US only): JONES, Stuart, Michael, Ruan [GB/GB]; 54 Front Street, Lockington, East Yorkshire YO25 9SH (GB). CAMPBELL, Simon, Alan [GB/GB]; 5 Humber Place, Hull Marina, Hull HU1 1UD (GB).</p> <p>(74) Agents: DICKSON, Elizabeth, Anne et al.; Reckitt Benckiser plc, Group Patents Department, Dansom Lane, Hull HU8 7DS (GB).</p>		<p>(81) Designated States: AE, AG, AL, AM, AT, AU, AZ, BA, BB, BG, BR, BY, CA, CH, CN, CR, CU, CZ, DE, DK, DM, DZ, EE, ES, FI, GB, GD, GE, GH, GM, HR, HU, ID, IL, IN, IS, JP, KE, KG, KP, KR, KZ, LC, LK, LR, LS, LT, LU, LV, MA, MD, MG, MK, MN, MW, MX, NO, NZ, PL, PT, RO, RU, SD, SE, SG, SI, SK, SL, TJ, TM, TR, TT, TZ, UA, UG, US, UZ, VN, YU, ZA, ZW, ARIPO patent (GH, GM, KE, LS, MW, SD, SL, SZ, TZ, UG, ZW), Eurasian patent (AM, AZ, BY, KG, KZ, MD, RU, TJ, TM), European patent (AT, BE, CH, CY, DE, DK, ES, FI, FR, GB, GR, IE, IT, LU, MC, NL, PT, SE), OAPI patent (BF, BJ, CF, CG, CI, CM, GA, GN, GW, ML, MR, NE, SN, TD, TG).</p> <p>Published <i>With international search report.</i></p>
<p>(54) Title: A PACKAGING DEVICE</p>		
<p>(57) Abstract</p> <p>A packaging device for protecting a trigger operated sprayer comprising a bottle and a spray gun attachment comprising a trigger, a shroud and a nozzle, said packaging device comprising a plurality of panels (7, 8, 9, 10) which together define a tube which is adapted to fit over the upper part of the sprayer with the lower edge (11) thereof seated on the bottle and to cover the trigger thereby hindering operation thereof, wherein one of the said panels (9) has an opening (13) therein in which the free end of the trigger engages to hinder operation of the trigger and removal of the packaging device.</p> <div data-bbox="874 1216 1364 1944" data-label="Image"> </div>		

FOR THE PURPOSES OF INFORMATION ONLY

Codes used to identify States party to the PCT on the front pages of pamphlets publishing international applications under the PCT.

AL	Albania	ES	Spain	LS	Lesotho	SI	Slovenia
AM	Armenia	FI	Finland	LT	Lithuania	SK	Slovakia
AT	Austria	FR	France	LU	Luxembourg	SN	Senegal
AU	Australia	GA	Gabon	LV	Latvia	SZ	Swaziland
AZ	Azerbaijan	GB	United Kingdom	MC	Monaco	TD	Chad
BA	Bosnia and Herzegovina	GE	Georgia	MD	Republic of Moldova	TG	Togo
BB	Barbados	GH	Ghana	MG	Madagascar	TJ	Tajikistan
BE	Belgium	GN	Guinea	MK	The former Yugoslav Republic of Macedonia	TM	Turkmenistan
BF	Burkina Faso	GR	Greece	ML	Mali	TR	Turkey
BG	Bulgaria	HU	Hungary	MN	Mongolia	TT	Trinidad and Tobago
BJ	Benin	IE	Ireland	MR	Mauritania	UA	Ukraine
BR	Brazil	IL	Israel	MW	Malawi	UG	Uganda
BY	Belarus	IS	Iceland	MX	Mexico	US	United States of America
CA	Canada	IT	Italy	NE	Niger	UZ	Uzbekistan
CF	Central African Republic	JP	Japan	NL	Netherlands	VN	Viet Nam
CG	Congo	KE	Kenya	NO	Norway	YU	Yugoslavia
CH	Switzerland	KG	Kyrgyzstan	NZ	New Zealand	ZW	Zimbabwe
CI	Côte d'Ivoire	KP	Democratic People's Republic of Korea	PL	Poland		
CM	Cameroon	KR	Republic of Korea	PT	Portugal		
CN	China	KZ	Kazakstan	RO	Romania		
CU	Cuba	LC	Saint Lucia	RU	Russian Federation		
CZ	Czech Republic	LI	Liechtenstein	SD	Sudan		
DE	Germany	LK	Sri Lanka	SE	Sweden		
DK	Denmark	LR	Liberia	SG	Singapore		
EE	Estonia						

A PACKAGING DEVICE

The present invention relates to a packaging device and more specifically to a collarette for use with trigger operated sprayers. The present invention also
5 relates to a packaging device in combination with a trigger operated sprayer.

Trigger operated sprayers are used for a wide range of household and garden fluids including cleaning
10 fluids, disinfectants, insecticides, herbicides and the like. Typically the sprayer comprises a bottle which is filled with fluid and a spray gun attachment which is fitted to the open top of the bottle by means of a screw
15 threaded or snap-on arrangement. The spray gun attachment consists of a shroud, a nozzle, a trigger and a tube. The tube extends into the fluid in the bottle and is in fluid communication with the nozzle. The
20 trigger operates a pump mechanism housed within the shroud which draws fluid up the tube and expels it through the nozzle. Usually the nozzle is adjustable between open and closed positions. To make for
comfortable operation the neck of the bottle and usually the shroud as well are shaped to provide a hand grip. Other types of trigger operated sprayer may be envisaged
25 and still fall within the scope of the present invention.

For a number of reasons, including to hinder accidental or unauthorised operation of the trigger
30 operated sprayer, it is increasingly common practice to fit a cardboard collarette over the sprayer for display at the point of purchase. The collarette takes the form of a tube of cardboard which is shaped and dimensioned to fit over the trigger operated sprayer with the lower
35 edge thereof seated on the sides of the bottle. The cardboard collarette covers the trigger thereby

hindering it from being either accidentally or deliberately depressed whilst simultaneously displaying on-pack promotions, for example discounts, or extra information on the product contained in the pack or.

5

In order to retain the collarette in place on the trigger operated sprayer a portion of the collarette is deformed to fold inwardly so that when the collarette is in position on a trigger operated sprayer the inwardly deformed portion thereof lies immediately beneath a downwardly facing surface of the shroud or nozzle of the trigger operated sprayer. This prevents it from slipping off. To facilitate this, crease lines along the deformable portion have to be formed in the blank from which the collarette is made.

10

Unfortunately, however, the above arrangement does not either hinder tampering or provide evidence of tampering as it is a relatively easy matter to 'un-deform' the inwardly folded portion out and slide the collarette off the trigger operated sprayer.

20

Also, the fitting of such a collarette to a trigger operated sprayer is a two stage labour intensive operation. The collarette must first be slipped over the sprayer and then subsequently deformed to engage underneath a downwardly facing surface of the shroud or nozzle.

25

It is an object of the present invention to provide a collarette which is more resistant to tampering and removal, is tamper evident, aesthetically pleasing, and which also provides product protection.

30

It is yet another object of the present invention to provide a collarette which can be fitted over a

35

sprayer in a single step operation.

According to a first aspect of the present invention there is provided a packaging device for
5 protecting a trigger operated sprayer comprising a bottle and a spray gun attachment comprising a trigger, a shroud and a nozzle, said packaging device comprising a plurality of panels which together define a tube which
10 is adapted to fit over the upper part of the sprayer with the lower edge of the device seated on the bottle and to cover the trigger thereby hindering operation thereof, wherein one of the said panels has an opening therein in which the free end of the trigger engages to
15 hinder operation of the trigger and removal of the packaging device.

Preferably, the said opening in the panel is in the form of a slot and the lower edge of the slot engages
20 against the underside of the trigger. The slot can be shaped to accommodate the shape of the trigger.

In a preferred embodiment of the present invention the collarette is comprised of front and rear panels and
25 two side panels, and the said slot is provided in one of the two side panels. Preferably, a line of weakness extends the length of one or both of the two side panels which facilitates deformation of the collarette to pass over the spray gun attachment and the trigger. It is
30 anticipated that the line of weakness will comprise a fold or crease line. However, the line may comprise perforations to facilitate opening the collarette for removal from the sprayer. It may be convenient with some trigger operated sprayers to provide more than one
35 line of weakness in each side panel.

Once in position on the trigger operated sprayer

the natural resiliency of the material from which the collarette is fabricated biases it to adopt its original shape or substantially its original shape, thereby ensuring a good fit of the collarette on the sprayer and preventing unauthorised or unintentional removal thereof
5 without damaging the collarette.

Preferably at least one of the panels of the collarette has an uppermost surface adapted to engage a
10 downwardly facing edge or surface of the shroud and/or nozzle, for example, by being reciprocally shaped to the edge or surface.

Preferably, the collarette is dimensioned such that
15 when in position over the trigger operated sprayer, the uppermost edge of at least one of the panels engages with a downwardly facing edge or surface of the shroud and/or the nozzle. In one embodiment the uppermost edge of one of the two side panels engages with the rear of
20 the shroud and/or the uppermost edge of the other side panel engages with the nozzle. This further improves the resistance of the collarette to tampering and unintentional removal.

The collarette is constructed from a blank
25 comprising a plurality of panels disposed side by side and means for joining the two end panels to form a tube. Preferably, one of the two end panels has a flap along one side which is joined to the other end panel by an
30 adhesive strip. Alternatively, the two end panels may be joined by mating or interlocking tabs. The blank can be fabricated from any sheet material, but typically is manufactured from card, paper or plastics.

35 Preferably the lowermost edges of each panel of the collarette are so shaped so as to accommodate a shape of

the bottle and/or not to obscure any graphics which may be presented on the side of the bottle and/or sprayer.

5 It will be appreciated that the benefits of the present invention are two-fold. Firstly, by the collarette being resilient and capable of adopting its original shape after deformation, it is a simple matter to fit the collarette to sprayer, the operation merely being a single step with the collarette 'self-adjusting'
10 to fit snugly on the sprayer. It is of great value that no second separate deformation step is required for at least one portion of the collarette to engage a downwardly facing surface of the sprayer.

15 Secondly, the more upper surfaces of the panels of the collarette that engage downwardly facing surfaces of the shroud or nozzle, the more difficult it becomes to remove the collarette from the sprayer without damaging the collarette.

20 Embodiments of the present invention will now be described, by way of example, with reference to the accompanying drawings, in which:

Fig. 1 is a perspective view of an embodiment of a collarette according to the present invention;

Fig. 2 is a perspective view of a household sprayer for use with the collarette of Fig. 1;

Fig. 3 is a partial perspective view of the collarette of Fig. 1 mounted on the household sprayer of Fig. 2;

Fig. 4 is a partial perspective view of an embodiment of a collarette according to the present invention fitted to a household sprayer of different design from the one shown in Fig. 2;

Fig. 5 is a partial perspective view of an embodiment of a collarette according to the present

invention fitted to a household sprayer of different design from the ones shown in Figs. 2 and 4;

Figs. 6, 7 and 8 each show blank for forming a collarette according to the present invention.

5

Referring to Fig. 1 of the drawings there is shown a collarette which is intended in use to fit over the upper part of the trigger operated sprayer shown in Fig. 2. The collarette can be seen in position over the sprayer in Fig. 3.

10

The trigger operated sprayer comprises a bottle 1 which is typically filled with a household cleaning fluid and a spray gun attachment, indicated generally as 2, secured to the top of the bottle 1. The spray gun attachment consists of a tube 3 which can be seen through the clear sides of the bottle 1 extending towards the bottom of the bottle 1, a shroud 4, a trigger 5 and a nozzle 6. The shroud 4 houses a simple pump arrangement (not shown) which is operated by the trigger 5 to draw fluid up the tube 3 and to expel it through the nozzle 6. It will be seen that the upper part of the bottle 1, the rear of the shroud 4 and the trigger are all shaped to facilitate holding the trigger operated sprayer comfortably in the hand with preferably the index finger on the trigger. It will be apparent from Fig. 3 that the collarette fits over the upper part of the sprayer to cover the trigger 5 and thereby hinder it from being operated.

20
25
30

The collarette takes the form of a four sided open ended tube comprising front and rear panels 7 and 8, and two side panels 9 and 10. The lowermost edges 11 of the front and rear panels 7, 8 are shaped to match labels (not shown) carried on the bottle 1. Each of the side panels 9 and 10 has a crease line 12 in the middle which

35

extends the full length thereof. (It will be appreciated that when the collarette is deformed along the crease lines 12, a six sided tube is formed as shown in Figure 1.) Additionally, one of the side panels 9 has an aperture or slot 13 cut in it. The purpose of the crease lines 12 and of the slot 13 will be explained hereinbelow.

The collarette shown in Fig. 1 is fabricated from the cardboard blank shown in Fig. 6. It will be seen that this comprises a flap 14 down one side of the side panel 9. To complete the collarette this flap 14 is joined to the free edge of the rear panel 8 by an adhesive strip. Two further blanks for the fabrication of collarettes according to the present invention are shown in Figs. 7 and 8. These differ from the blank of Fig. 6 in the shape of the front and rear panel 7 and 8, in the upper surfaces of the side panels 9 and 10 and in the shape of the slot 13, but otherwise they are the same.

The collarette shown in Fig. 1 is fitted onto the sprayer shown in Fig. 2 by sliding it down over the top thereof. The distance between the side panels 9 and 10 is such as to be equal to or preferably slightly less than the maximum distance between the front and rear of the spray gun attachment 2, including the trigger 5. The closeness of the fit between the collarette and the spray gun attachment 2 is accommodated by the crease lines 12 in the side panels 9 and 10. These allow the collarette to deform or "stretch" as it passes over the spray gun attachment. The collarette is in its final position when the trigger 5 is engaged in the slot 13 and the uppermost edge of the side panel 10 lies under the rear of the shroud 4 as shown in Fig. 3. Engagement of the trigger 5 in the slot 13 and of the upper edge of

the side panel 10 with the rear of the shroud 4 is facilitated by the natural resiliency of the material from which the collarette is made which biases each of the side panels 9 and 10 to resume its original shape about the crease line 12, thus effectively decreasing the distance between the side panels 9 and 10. It may also be facilitated to some extent by any play in the trigger 5 itself.

10 It will be understood that once the trigger 5 is engaged in the slot 13 it cannot easily be depressed; the underside of the trigger 5 is supported against the lower edge of the slot 13. Only by crushing the collarette can the trigger 5 be operated. It will also
15 be apparent that the collarette cannot be easily removed once it is in position. Not only must the trigger 5 be disengaged from the slot 13 in the side panel 9, but the uppermost edge of the side panel 10 must be disengaged from under the rear of the shroud 4. This effectively
20 requires the collarette to be "stretched" open. Indeed, it is envisaged that the collarette will usually need to be torn open to remove it.

Referring to Fig. 4 of the drawings there is shown
25 a collarette according to the present invention fitted to a sprayer of a different design to the one shown in Fig. 2. Here the shroud of the sprayer does not define a downwardly facing edge or surface at the rear against which the uppermost edge of the side panel can engage.
30 Consequently, the collarette is held in place only by the engagement of the trigger in the slot.

Referring to Fig. 5 of the drawings there is shown
35 a collarette according to the present invention fitted to a sprayer of yet another design to the ones shown in Figs. 2, 3 and 4. In this case the sprayer defines

downwardly facing surfaces at both the front, under the nozzle, and at the rear, under the shroud, and the uppermost edges of both side panels engage against these to further secure the collarette in place.

5

The design of the collarette according to the present invention is such that it can be slipped into position over the top of a trigger operated sprayer in a single operation. There are no tabs or corners which
10 must be folded over to secure the collarette in place, as is the case with known collarettes. This makes the collarette according to the present invention ideally suited to both machine fitting and hand application. In
15 either instance, the fitment of the collarette is easy and quick to apply resulting in substantial cost benefits.

CLAIMS

1. A packaging device for protecting a trigger operated sprayer comprising a bottle and a spray gun attachment comprising a trigger, a shroud and a nozzle, said packaging device comprising a plurality of panels which together define a tube which is adapted to fit over the upper part of the sprayer with the lower edge thereof seated on the bottle and to cover the trigger thereby hindering operation thereof, wherein one of the said panels has an opening therein in which the free end of the trigger engages to hinder operation of the trigger and removal of the packaging device.
2. A packaging device according to Claim 1, wherein the said opening in the panel is in the form of a slot and the lower edge of the slot is adapted to engage against the underside of the trigger.
3. A packaging device according to Claim 2, wherein the slot is shaped to accommodate the shape of the trigger.
4. A packaging device according to any one of Claims 1, 2 or 3, wherein the packaging device is comprised of front and rear panels and two side panels, and the said slot is provided in one of the two side panels.
5. A packaging device according to Claim 5, wherein at least one line of weakness extends the length of one or both of the two side panels which facilitates deformation of the collarette to pass over the spray gun attachment and the trigger.
6. A packaging device according to Claim 4, wherein the line of weakness comprises a fold or crease line.

7. A packaging device according to Claim 5, wherein the line of weakness comprises perforations.

5 8. A packaging device as claimed in any one of claims 5 to 7 wherein the device is biased to adopt its original shape after deformation of the collarette to pass over the spray gun attachment and the trigger.

10 9. A packaging device according to any preceding claims wherein at least one of the panels has an uppermost surface adapted to engage a downwardly facing edge or surface of the shroud and/or nozzle.

15 10. A packaging device according to any preceding Claim in combination with a trigger operated sprayer.

11. A combination according to Claim 10, wherein the uppermost edge of at least one of the panels comprising
20 the packaging device engages with a downwardly facing edge or surface of the shroud and/or the nozzle.

12. A combination according to Claim 11, wherein the uppermost edge of one panel engages with the rear of
25 the shroud and/or the uppermost edge of another panel engage with the nozzle.

13. A packaging device substantially as hereinbefore described with reference to the accompanying drawings.

30

14. A packaging device in combination with a trigger operated sprayer substantially as hereinbefore described with reference to the accompanying drawings.

Fig.1.

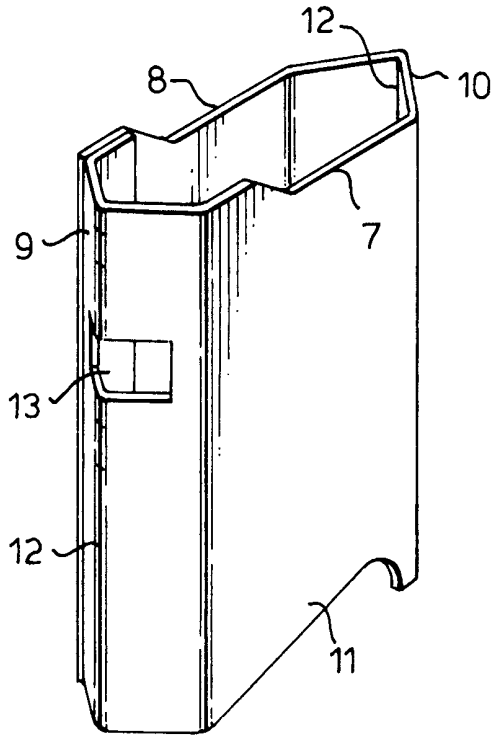

Fig.2.

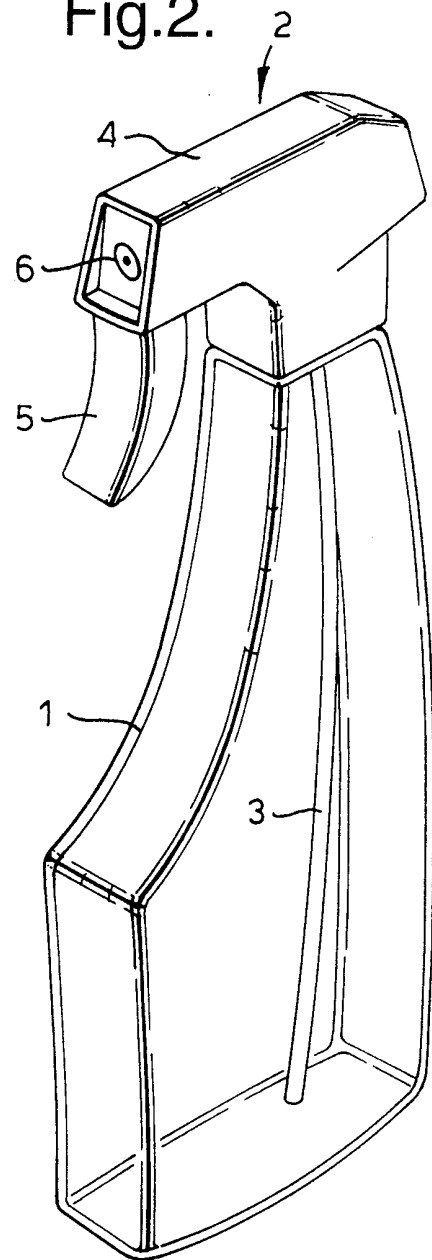

Fig.3.

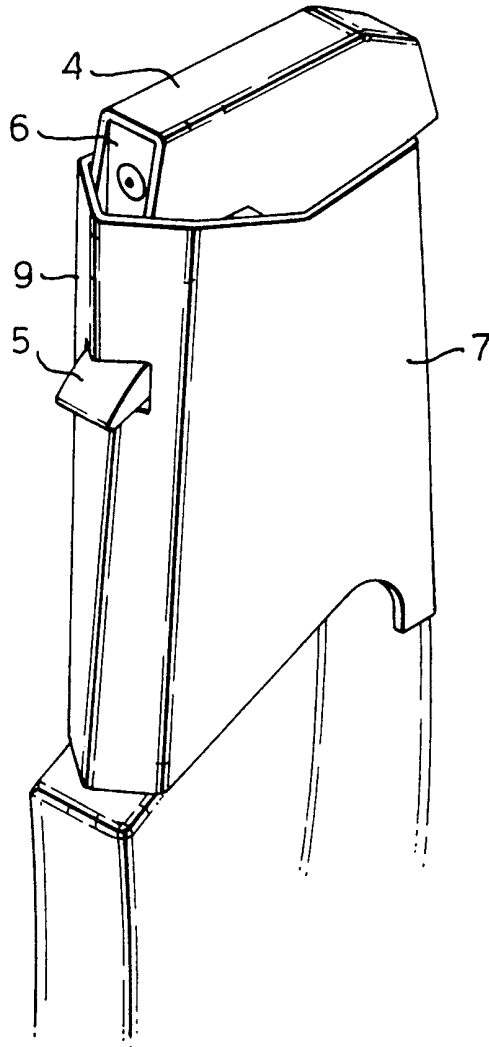

Fig.4.

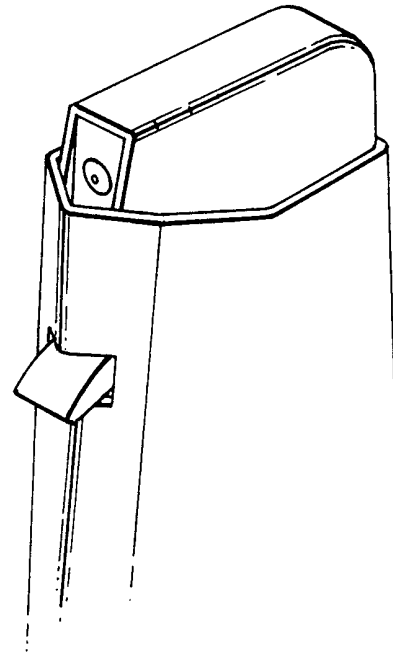
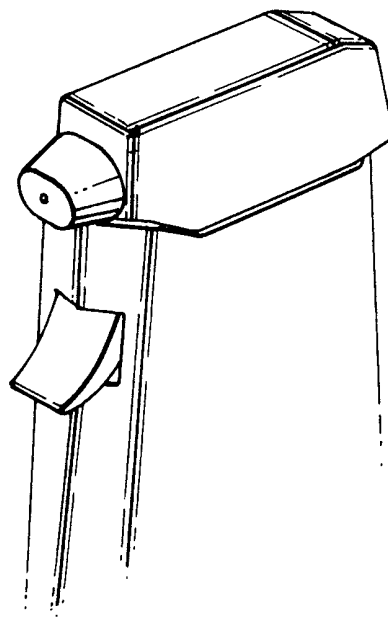
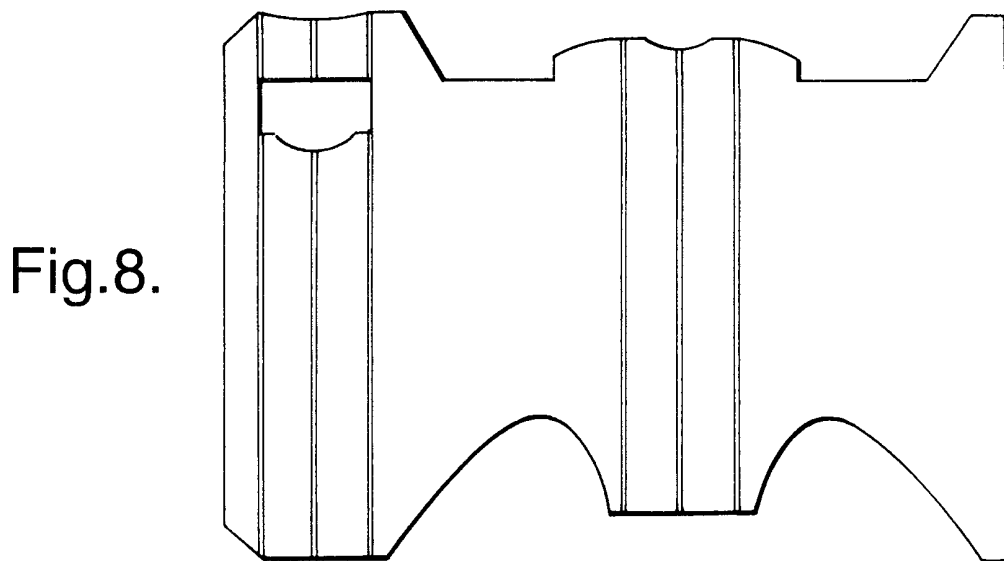
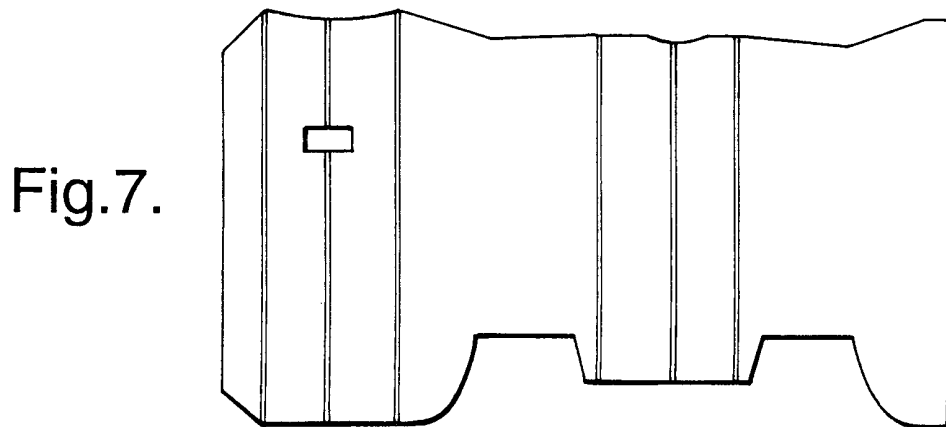
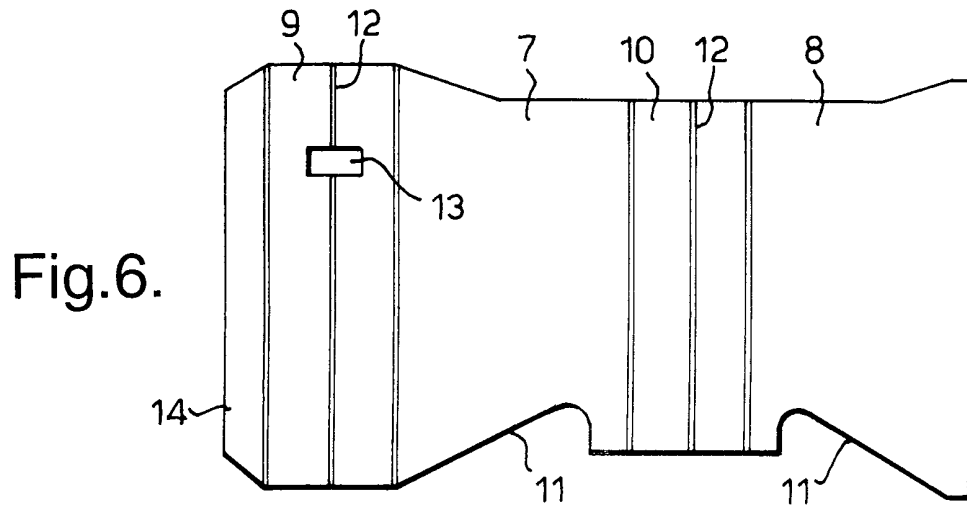

Fig.5.





INTERNATIONAL SEARCH REPORT

International Application No

PCT/GB 00/00944

A. CLASSIFICATION OF SUBJECT MATTER
 IPC 7 B05B11/00 B65D5/04

According to International Patent Classification (IPC) or to both national classification and IPC

B. FIELDS SEARCHED

Minimum documentation searched (classification system followed by classification symbols)

IPC 7 B05B H03L B65D

Documentation searched other than minimum documentation to the extent that such documents are included in the fields searched

Electronic data base consulted during the international search (name of data base and, where practical, search terms used)

C. DOCUMENTS CONSIDERED TO BE RELEVANT

Category *	Citation of document, with indication, where appropriate, of the relevant passages	Relevant to claim No.
X	GB 1 144 769 A (TILLOTSONS (LIVERPOOL) LIMITED) 12 March 1969 (1969-03-12)	1-6, 8, 9
A	page 1, column 2, line 49 - line 56 page 2, column 1, line 1 - line 16 page 2, column 1, line 48 - line 54; figures 1, 2	7, 10-14
X	DE 933 978 C (N.V. PHILIPS GLOEILAMPENFABRIEKEN) 8 September 1955 (1955-09-08)	1-6
A	page 2, column 2, line 79 - line 89 page 3, column 1, line 15 - line 19; figure 1	10-14
A	US 5 441 178 A (WYSOCKI J CHRISTOPHER) 15 August 1995 (1995-08-15) column 3, line 8 - line 29; figure 1	1
	-/--	

Further documents are listed in the continuation of box C.

Patent family members are listed in annex.

* Special categories of cited documents :

- "A" document defining the general state of the art which is not considered to be of particular relevance
- "E" earlier document but published on or after the international filing date
- "L" document which may throw doubts on priority claim(s) or which is cited to establish the publication date of another citation or other special reason (as specified)
- "O" document referring to an oral disclosure, use, exhibition or other means
- "P" document published prior to the international filing date but later than the priority date claimed

- "T" later document published after the international filing date or priority date and not in conflict with the application but cited to understand the principle or theory underlying the invention
- "X" document of particular relevance; the claimed invention cannot be considered novel or cannot be considered to involve an inventive step when the document is taken alone
- "Y" document of particular relevance; the claimed invention cannot be considered to involve an inventive step when the document is combined with one or more other such documents, such combination being obvious to a person skilled in the art.
- "&" document member of the same patent family

Date of the actual completion of the international search

15 June 2000

Date of mailing of the international search report

29/06/2000

Name and mailing address of the ISA

European Patent Office, P.B. 5818 Patentlaan 2
 NL - 2280 HV Rijswijk
 Tel. (+31-70) 340-2040, Tx. 31 651 epo nl,
 Fax: (+31-70) 340-3016

Authorized officer

Jelercic, D

INTERNATIONAL SEARCH REPORT

International Application No
PCT/GB 00/00944

C.(Continuation) DOCUMENTS CONSIDERED TO BE RELEVANT		
Category *	Citation of document, with indication, where appropriate, of the relevant passages	Relevant to claim No.
A	EP 0 838 266 A (CALMAR ALBERT GMBH) 29 April 1998 (1998-04-29) column 2, line 50 -column 3, line 17; figures 1,2 -----	1
A	EP 0 827 283 A (NIPPON ELECTRIC CO) 4 March 1998 (1998-03-04) column 4, line 6 - line 17; figure 1 -----	1

INTERNATIONAL SEARCH REPORT

Information on patent family members

International Application No

PCT/GB 00/00944

Patent document cited in search report	Publication date	Patent family member(s)	Publication date
GB 1144769	A	NONE	
DE 933978	C	NONE	
US 5441178	A	15-08-1995	NONE
EP 0838266	A	29-04-1998	AU 718540 B 13-04-2000 AU 3243997 A 30-04-1998 BR 9704643 A 01-12-1998 CN 1180590 A 06-05-1998 DE 69600294 D 09-07-1998 DE 69600294 T 24-12-1998 ES 2117470 T 01-08-1998 HU 9701535 A 28-12-1998 JP 10128186 A 19-05-1998 PL 321918 A 27-04-1998 US 5823396 A 20-10-1998
EP 0827283	A	04-03-1998	JP 10070458 A 10-03-1998 US 5986485 A 16-11-1999