

(19) World Intellectual Property Organization  
International Bureau



(43) International Publication Date  
10 September 2010 (10.09.2010)

(10) International Publication Number  
**WO 2010/101855 A2**

(51) International Patent Classification:  
C07C 7/09 (2006.01)

(21) International Application Number:  
PCT/US2010/025826

(22) International Filing Date:  
2 March 2010 (02.03.2010)

(25) Filing Language: English

(26) Publication Language: English

(30) Priority Data:  
61/202,474 3 March 2009 (03.03.2009) US

(71) Applicant (for all designated States except US):  
AMYRIS BIOTECHNOLOGIES, INC. [US/US]; 5885  
Hollis Street, Suite 100, Emeryville, CA 94608 (US).

(72) Inventor; and

(75) Inventor/Applicant (for US only): MCPHEE, Derek  
[CA/US]; 5885 Hollis Street, Suite 100, Emeryville, CA  
94608 (US).

(74) Agents: INSOGNA, Anthony, M. et al.; Jones Day, 222  
East 41st Street, New York, NY 10017-6702 (US).

(81) Designated States (unless otherwise indicated, for every  
kind of national protection available): AE, AG, AL, AM,

AO, AT, AU, AZ, BA, BB, BG, BH, BR, BW, BY, BZ,  
CA, CH, CL, CN, CO, CR, CU, CZ, DE, DK, DM, DO,  
DZ, EC, EE, EG, ES, FI, GB, GD, GE, GH, GM, GT,  
HN, HR, HU, ID, IL, IN, IS, JP, KE, KG, KM, KN, KP,  
KR, KZ, LA, LC, LK, LR, LS, LT, LU, LY, MA, MD,  
ME, MG, MK, MN, MW, MX, MY, MZ, NA, NG, NI,  
NO, NZ, OM, PE, PG, PH, PL, PT, RO, RS, RU, SC, SD,  
SE, SG, SK, SL, SM, ST, SV, SY, TH, TJ, TM, TN, TR,  
TT, TZ, UA, UG, US, UZ, VC, VN, ZA, ZM, ZW.

(84) Designated States (unless otherwise indicated, for every  
kind of regional protection available): ARIPO (BW, GH,  
GM, KE, LS, MW, MZ, NA, SD, SL, SZ, TZ, UG, ZM,  
ZW), Eurasian (AM, AZ, BY, KG, KZ, MD, RU, TJ,  
TM), European (AT, BE, BG, CH, CY, CZ, DE, DK, EE,  
ES, FI, FR, GB, GR, HR, HU, IE, IS, IT, LT, LU, LV,  
MC, MK, MT, NL, NO, PL, PT, RO, SE, SI, SK, SM,  
TR), OAPI (BF, BJ, CF, CG, CI, CM, GA, GN, GQ, GW,  
ML, MR, NE, SN, TD, TG).

Published:

- without international search report and to be republished upon receipt of that report (Rule 48.2(g))
- with sequence listing part of description (Rule 5.2(a))

(54) Title: MICROBIAL DERIVED ISOPRENE AND METHODS FOR MAKING THE SAME

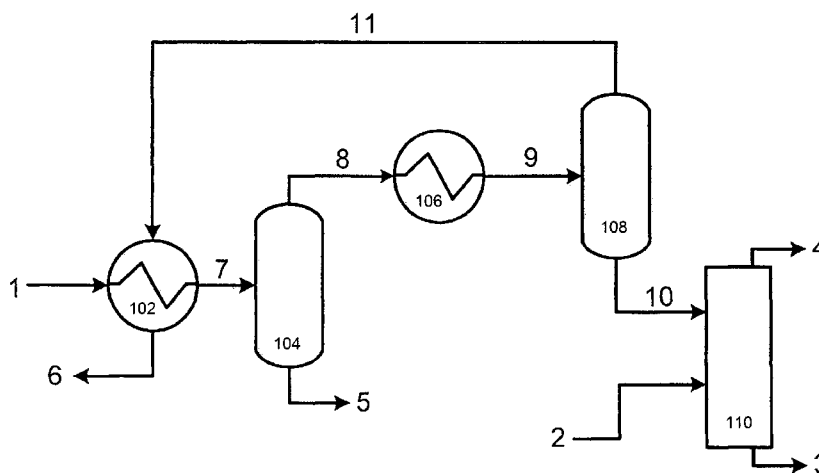

FIG. 1

(57) Abstract: A method for producing isoprene comprising an aqueous medium including genetically modified host cells capable of producing isoprene, where the resulting isoprene composition is processed through at least one separation and/or purification process to provide an isoprene enriched composition and a system for doing the same.

WO 2010/101855 A2

## MICROBIAL DERIVED ISOPRENE AND METHODS FOR MAKING THE SAME

### CROSS REFERENCE TO RELATED APPLICATION

[0001] This application claims the benefit of priority from U.S. Provisional Application No. 61/202,474, filed March 3, 2009. The priority application, in its entirety, is incorporated herein by reference.

### BACKGROUND OF THE INVENTION

[0002] Isoprene is a five carbon hydrocarbon (2-methyl-1,3-butadiene), that is an industrial chemical used in a range of industrial application such as tires, footwear, sporting goods, latex, tapes, labels, and medical disposables. Isoprene is also a natural compound produced in biological systems. While isoprene is made naturally in various organisms ranging from microbes to animals, most naturally occurring isoprene has traditionally been extracted from rubber plants. However, extraction yields are low and these quantities are far less than are required for many commercial applications. As a result, isoprene is primarily produced synthetically from petroleum sources, most often from ethylene using a steam cracking process.

[0003] Due to the growing concern for climate change and thus a need to make products we need more sustainably, there is an urgent need for bio- or renewable isoprene that will help meet global isoprene demands but that can be produced in a more environmentally friendly way. The current invention addresses this need.

### SUMMARY OF THE INVENTION

[0004] The present invention provides microbial derived isoprene compositions and methods for making and purifying the same.

[0005] In one aspect of the invention, a gaseous isoprene composition is provided comprising: isoprene and water wherein the water is present in an amount greater than about 70% of its saturation amount and wherein the gaseous isoprene composition comprises 1 part per million or less than 1 part per million of any one of the following impurities: C<sub>2</sub>-C<sub>5</sub> alkynes, cyclopentadiene, piperylene, and 1,4-pentadiene.

[0006] In another aspect a liquid isoprene composition is provided comprising: at least 65% isoprene by weight and wherein the isoprene composition comprises 1 part per

million or less than 1 part per million of any one of the following impurities: C<sub>2</sub>-C<sub>5</sub> alkynes, cyclopentadiene, piperylene, and 1,4-pentadiene.

**[0007]** In another aspect, a method for making and purifying isoprene is provided.

The method comprises:

- a. obtaining a first gaseous composition comprising isoprene and water wherein the gaseous composition comprises 1 part per million or less of C<sub>2</sub>-C<sub>5</sub> alkynes;
- b. flowing the first gaseous composition through a first chiller wherein the first chiller has a temperature of between about 10 °C and about -15 °C thereby resulting in a second gaseous composition and wherein the second gaseous composition comprises less water than the first gaseous composition;
- c. flowing the second gaseous composition through a second chiller wherein the second chiller has a temperature below -35 °C; and
- d. collecting the resulting liquid isoprene composition.

**[0008]** In another aspect, another method is provided. The method comprises:

- a. culturing a plurality of host cells capable of making isoprene;
- b. forming a first gaseous composition comprising isoprene and water wherein the water is present in an amount greater than about 70% of its saturation amount;
- c. subjecting the first gaseous composition to a first cooling step whereby substantially all of the water is removed from the first gaseous composition resulting a second gaseous composition; and
- d. subjecting the second gaseous composition to a second cooling step whereby a liquid isoprene composition is collected.

**[0009]** In another aspect, another method is provided. The method comprises:

- a. culturing a plurality of host cells capable of making isoprene;
- b. forming a first gaseous composition comprising isoprene and water wherein the water is present in an amount greater than about 70% of its saturation amount;

- c. subjecting the first gaseous composition to a first cooling step whereby substantially all of the water is removed from the first gaseous composition resulting a second gaseous composition;
- d. subjecting the second gaseous composition to a second cooling step whereby a liquid isoprene composition is collected; and
- e. optionally, contacting either the first gaseous composition, the second gaseous composition and/or the liquid isoprene composition with a membrane containing modified zeolites or molecular seive to provide a purified isoprene composition.

**[0010]** In another aspect, another method is provided. The method comprises:

- a. contacting a plurality of host cells capable of making isoprene in an aqueous medium wherein the aqueous medium is in contact with an immiscible organic liquid and the aqueous medium, the host cells, and the immiscible organic liquid is in a closed vessel; and
- b. culturing the host cells in the aqueous medium whereby the host cells make isoprene and the isoprene is captured in the immiscible organic liquid.

**[0011]** In another aspect, another method is provided. The method comprises:

- a. obtaining a first gaseous composition comprising:
  - i. isoprene in an amount between about 0.1% and about 15% by volume;
  - ii. carbon dioxide in an amount between about 0.04% and about 35% by volume;
  - iii. oxygen in an amount between about 1% and about 20% by volume;
  - iv. nitrogen in an amount greater than about 50% by volume;
  - v. argon in an amount less than about 0.9% by volume;
  - vi. water in an amount greater than about 70% of its saturation amount;
  - vii. 1 part per million or less of C2-C5 alkyne, cyclopentadiene, piperylene, and 1,4-pentadiene; and
  - viii. ethanol;
- b. flowing the first gaseous composition through a first chiller and an operably connected flash drum, wherein the first chiller has a temperature of between about 10 °C and about -15 °C thereby resulting in a second

- gaseous composition and wherein the second gaseous composition comprises less water than the first gaseous composition;
- c. flowing the second gaseous composition through a second chiller and an operably connected flash drum, wherein the second chiller has a temperature between about 35°C and about -85°C; and
  - d. collecting the resulting liquid isoprene composition.

- [0012]** An isoprene production system comprising:
- a. a bioreactor capable of culturing a plurality of host cells;
  - b. a first chiller and flash drum operably connected to the overhead stream of the bioreactor, the first chiller capable of operating in a temperature range of between 10°C and -15°C; and
  - c. a second chiller and flash drum operably connected to the overhead stream exiting from the first chiller and flash drum, the second chiller capable of operating in a temperature below -35°C.

- [0013]** In yet another aspect, an isoprene production system is provided. The system comprises:
- a. a closed vessel;
  - b. an aqueous medium, within the vessel, forming a first phase;
  - c. a plurality of host cells, within the aqueous medium, capable of making isoprene; and,
  - d. a liquid organic second phase, capable of capturing the isoprene made by the host cells, in contact with the first phase.

#### **BRIEF DESCRIPTION OF THE DRAWINGS**

**[0014]** Figure 1 is a schematic representation of an exemplary separation system.

**[0015]** Figure 2 is another schematic representation of another exemplary separation system.

**[0016]** Figure 3 is a schematic representation of the mevalonate (“MEV”) pathway for the production of isopentenyl diphosphate (“IPP”).

**[0017]** Figure 4 is a schematic representation of the DXP pathway for the production of IPP and dimethylallyl pyrophosphate (“DMAPP”). Dxs is 1-deoxy-D-

xylulose-5-phosphate synthase; Dxr is 1-deoxy-D-xylulose-5-phosphate reductoisomerase (also known as IspC); IspD is 4-diphosphocytidyl-2C-methyl-D-erythritol synthase; IspE is 4-diphosphocytidyl-2C-methyl-D-erythritol synthase; IspF is 2C-methyl-D-erythritol 2,4-cyclodiphosphate synthase; IspG is 1-hydroxy-2-methyl-2-(E)-butenyl 4-diphosphate synthase (IspG); and ispH is isopentenyl/dimethylallyl diphosphate synthase.

[0018] Figure 5 shows the recovery of isoprene from an immiscible organic liquid (isopropyl myristate) from a closed fermentation system.

[0019] Figure 6 shows a map of plasmid pAM1547.

[0020] Figures 7A-G show maps of the inserts of vectors pAM489, pAM491, pAM493, pAM495, pAM497, and pAM584, and of the integration cassette natA-P<sub>CTR3</sub><sup>-1 to -734</sup>.

[0021] Figure 8 shows a map of the pMULE Entry vector.

## DETAILED DESCRIPTION OF THE INVENTION

### *Definitions*

[0022] Unless defined otherwise, all technical and scientific terms used herein have the same meaning as commonly understood by one of ordinary skill in the art to which this invention belongs. Reference is made here to a number of terms that shall be defined to have the following meanings:

[0023] “Bio-organic compound” refers to an organic compound having at least five carbon atoms that can be made by a host cell by taking a carbohydrate carbon source and converting the carbohydrate carbon source into the desired product.

[0024] “Deoxyxylulose 5-phosphate pathway” or “DXP pathway” is used herein to refer to the pathway that converts glyceraldehyde-3-phosphate and pyruvate to IPP and DMAPP. The DXP pathway is illustrated schematically in Figure 4.

[0025] “Endogenous” refers to a substance or process that can occur naturally, *e.g.*, in a non-recombinant host cell.

[0026] “Heterologous nucleic acid” as used herein refers to a nucleic acid wherein at least one of the following is true: (a) the nucleic acid is foreign (“exogenous”) to (that is, not naturally found in) a given host cell; (b) the nucleic acid comprises a nucleotide sequence that is naturally found in (that is, is “endogenous to”) a given host cell, but the nucleotide sequence is produced in an unnatural (for example, greater than expected or greater than naturally found) amount in the cell; (c) the nucleic acid comprises a nucleotide sequence that differs in sequence from an endogenous nucleotide sequence, but

the nucleotide sequence encodes the same protein (having the same or substantially the same amino acid sequence) and is produced in an unnatural (for example, greater than expected or greater than naturally found) amount in the cell; or (d) the nucleic acid comprises two or more nucleotide sequences that are not found in the same relationship to each other in nature (for example, the nucleic acid is recombinant).

[0027] “Host cell” and “microorganism” are used interchangeably herein to refer to any archae, bacterial, or eukaryotic living cell into which a heterologous nucleic acid can be or has been inserted. The term also relates to the progeny of the original cell, which may not necessarily be completely identical in morphology or in genic or total DNA complement to the original parent, due to natural, accidental, or deliberate mutation.

[0028] “Isoprenoid” and “isoprenoid compound” are used interchangeably herein and refer to a compound derivable from isopentenyl diphosphate.

[0029] “Isolate” and “isolating” when referred to a bio-organic compound is the enrichment of the amount of the bio-organic compound in a composition. Consequently, the amount of the bio-organic compound in a composition after the bio-organic compound has been isolated or subject to an isolating step is greater than the amount present in the composition prior to such step.

[0030] “Mevalonate pathway” or “MEV pathway” is used herein to refer to the biosynthetic pathway that converts acetyl-CoA to IPP. The MEV pathway is illustrated schematically in Figure 3.

[0031] “Naturally occurring” as applied to a nucleic acid, an enzyme, a cell, or an organism, refers to a nucleic acid, enzyme, cell, or organism that is found in nature. For example, a polypeptide or polynucleotide sequence that is present in an organism that can be isolated from a source in nature and that has not been intentionally modified by a human in the laboratory is naturally occurring.

[0032] “Optional” or “optionally” means that the subsequently described feature or structure may or may not be present, or that the subsequently described event or circumstance may or may not occur, and that the description includes instances where a particular feature or structure is present and instances where the feature or structure is absent, or instances where the event or circumstance occurs and instances where the event or circumstance does not occur.

[0033] “Pyrophosphate” is used interchangeably herein with “diphosphate”.

[0034] As used herein, a composition that is a “substantially pure” compound is substantially free of one or more other compounds, *i.e.*, the composition contains greater

than 80 vol.% , greater than 90 vol.%, greater than 95 vol.%, greater than 96 vol.%, greater than 97 vol.%, greater than 98 vol.%, greater than 99 vol.%, greater than 99.5 vol.%, greater than 99.6 vol.%, greater than 99.7 vol.%, greater than 99.8 vol.%, greater than 99.9 vol.% of the compound; or less than 20 vol.%, less than 10 vol.%, less than 5 vol.%, less than 4 vol.%, less than 3 vol.%, less than 2 vol.%, less than 1 vol.%, less than 0.5 vol.%, less than 0.1 vol.%, or less than 0.01 vol.% of the one or more other compounds, based on the total volume of the composition.

[0035] In the following description, all numbers disclosed herein are approximate values, regardless whether the word “about” or “approximate” is used in connection therewith. They may vary by 1 percent, 2 percent, 5 percent, or, sometimes, 10 to 20 percent. Whenever a numerical range with a lower limit, RL and an upper limit, RU, is disclosed, any number falling within the range is specifically disclosed. In particular, the following numbers within the range are specifically disclosed:  $R=RL+k*(RU-RL)$ , wherein k is a variable ranging from 1 percent to 100 percent with a 1 percent increment, i.e., k is 1 percent, 2 percent, 3 percent, 4 percent, 5 percent, ..., 50 percent, 51 percent, 52 percent, ..., 95 percent, 96 percent, 97 percent, 98 percent, 99 percent, or 100 percent. Moreover, any numerical range defined by two R numbers as defined in the above is also specifically disclosed.

[0036] In addition to the definitions above, certain compounds described herein have one or more double bonds that can exist as either the Z or E isomer. The invention in certain embodiments encompasses these compounds as individual isomers in a substantially pure form as well as mixtures of various isomers, e.g., racemic mixtures of stereoisomer.

### ***Current Sources of Isoprene***

[0037] Isoprene currently is made naturally by rubber plants (typically *Hevea brasiliensis*) or is made synthetically from petroleum sources. When made naturally, the sap-like extract (known as latex and is a polymerized version of isoprene) is collected from the rubber plants and is the primary source of natural rubber. Because latex and natural rubber can be of varying quality (irregular molecular distribution), the synthetic analog of natural rubber or polyisoprene is often preferred due to its higher uniformity.

[0038] Chemically synthesized isoprene is made primarily from petroleum sources. The most common method involves stream cracking a petroleum stream to make ethylene which in turn is subsequently converted into isoprene. Other methods for making

isoprene include isobutylene carbonylation and isopentane dehydrogenation. The resulting isoprene is produced and sold in different concentrations. Crude isoprene has a purity between 15% and 65%. Refined isoprene is defined as isoprene having a purity between 65% and 95%. High purity isoprene is defined as isoprene having a purity between 95% and 99.5%. Polymer grade isoprene is isoprene with a purity exceeding 99.5%.

[0039] As a consequence of how it is made, synthetic isoprene contains a number of impurities including various acetylenes and dienes such as cyclopentadiene and piperylene. Although these catalysts are undesirable as they inhibit polymerization, it is not often economical to entirely eliminate them and the purity of the isoprene is matched to the desired end product. For example, the isoprene purity required to make butyl rubber is substantially less than required to make SIS polymers (polymer grade).

#### ***Microbially Derived Gaseous Isoprene Compositions***

[0040] The present invention provides microbial derived isoprene compositions and methods for making and purifying the same. Microbial-derived isoprene compositions differ from petroleum derived sources in that the compositions include virtually none of the following impurities: C<sub>2</sub>-C<sub>5</sub> alkynes; cyclopentadiene, piperylene and 1,4-pentadiene.

[0041] In one aspect of the invention, a gaseous isoprene composition is provided. The composition comprises isoprene and water wherein the water is present in an amount that is at least about 70% of its saturation amount and the composition comprises 1 part per million or less of C<sub>2</sub>-C<sub>5</sub> alkynes. Illustrative examples of C<sub>2</sub>-C<sub>5</sub> alkynes include acetylene, isopropylacetylene, 1-pentyne, 2-pentyne, and 2-butyne.

[0042] In another aspect of the invention, another gaseous isoprene composition is provided. The composition comprises isoprene and water wherein the water is present in an amount that is at least about 70% of its saturation amount and the composition comprises 1 part per million or less of cyclopentadiene.

[0043] In another aspect of the invention, another gaseous isoprene composition is provided. The composition comprises isoprene and water wherein the water is present in an amount that is at least about 70% of its saturation amount and the composition comprises 1 part per million or less of piperylene.

[0044] In another aspect of the invention, another gaseous isoprene composition is provided. The composition comprises isoprene and water wherein the water is present in

an amount that is at least about 70% of its saturation amount and the composition comprises 1 part per million or less of 1,4-pentadiene.

[0045] In another aspect of the invention, another gaseous isoprene composition is provided. The composition comprises isoprene and water wherein the water is present in an amount that is at least about 70% of its saturation amount and the composition comprises 1 part per million or less of each of C<sub>2</sub>-C<sub>5</sub> alkynes, cyclopentadiene, piperylene, and 1,4-pentadiene.

[0046] In some embodiments, the gaseous isoprene composition comprises isoprene that is present between about 0.1% and about 15% by volume. In other embodiments, the isoprene is present between about 1 and 10% by volume. In still other embodiments, the isoprene is present between about 1 and 5% by volume. In yet other embodiments, the isoprene is present between about 5% and about 10% by volume. In further embodiments, the isoprene is present between in an amount greater than about 10% by volume.

[0047] In other embodiments, the gaseous isoprene composition comprises water in an amount that is greater than about 70%, 75%, 80%, 85%, 90%, 95% and 99% of its saturation amount. In still other embodiments, the gaseous isoprene composition comprises saturated water.

[0048] In other embodiments, the gaseous isoprene composition further comprises carbon dioxide that is present in an amount that is greater than about 0.04% by volume. In still other embodiments, the carbon dioxide is present in an amount that is greater than about 0.05%, 0.1%, 0.5%, 1.0%, and 5% by volume. In further embodiments, the carbon dioxide is present in an amount that is greater than about 10%, about 20%, about 30% by volume. In still further embodiments, the carbon dioxide is present in an amount that is between about 1% and about 35% by volume. In still other embodiments, the carbon dioxide is present in an amount that is between about 10% and about 30% by volume.

[0049] In other embodiments, the gaseous isoprene composition further comprises oxygen. In some embodiments, the oxygen is present in an amount that is less than about 20.9% by volume. In other embodiments, the oxygen is present in an amount that is between about 1% by volume and about 20% by volume. In other embodiments, the oxygen is present in an amount that is between about 8% and about 15% by volume. In other embodiments, the oxygen is present in an amount that is less than about 20%, 15%, 10%, 9%, 8%, 7%, 6%, 5%, 4%, 3%, and 2%. In still other embodiments, the oxygen is present in an amount that is less than about 1% by volume. In further embodiments, the

oxygen is present between about 1% and about 15% by volume. In still further embodiments, the oxygen is present between about 5% and about 15% by volume.

**[0050]** In other embodiments, the gaseous isoprene composition further comprises nitrogen. In some embodiments, the nitrogen is present in an amount between about 50% and about 75% by volume. In further embodiments, the nitrogen is present in an amount that is greater than about 70%. In other embodiments, the nitrogen is present in an amount that is greater than about 75%, 76%, 77%, 78%, 79%, and 80%.

**[0051]** In other embodiments, the gaseous isoprene composition further comprises argon. In some embodiments, the argon is present in an amount that is less than about 0.9% by volume. In other embodiments, the argon is present in an amount that is greater than about 1.0% by volume.

**[0052]** In other embodiments, the gaseous isoprene composition further comprises ethanol. In some embodiments, the ethanol is present in an amount that is less than about 0.5% by volume. In other embodiments, the ethanol is present in an amount that is more than about 1% by volume.

**[0053]** In other embodiments, the microbial-derived gaseous isoprene composition may comprise: isoprene in an amount between about 0.1% and about 15% by volume; water in an amount that is greater than about 70% of its saturation amount; carbon dioxide in an amount that is between about 0.04% and about 35% by volume; oxygen in an amount that is between about 1% and about 20% by volume; nitrogen in an amount that is greater than about 50% by volume; argon in an amount that is less than about 0.9% by volume; ethanol in an amount that is less than about 0.5% by volume; 1 part per million or less of C<sub>2</sub>-C<sub>5</sub> alkynes; 1 part per million or less of cyclopentadiene; 1 part per million or less of piperylene; and 1 part per million or less of 1,4-pentadiene.

**[0054]** In other embodiments, the microbial-derived gaseous isoprene composition may comprise: isoprene in an amount between about 0.1% and about 15% by volume; water in an amount that is greater than about 70% of its saturation amount; carbon dioxide in an amount that is between about 0.04% and about 35% by volume; oxygen in an amount that is between about 1% and about 20% by volume; nitrogen in an amount that is greater than about 50% by volume; argon in an amount that is greater than about 1.0% by volume; ethanol in an amount that is more than about 1% by volume; 1 part per million or less of C<sub>2</sub>-C<sub>5</sub> alkynes; 1 part per million or less of cyclopentadiene; 1 part per million or less of piperylene; and 1 part per million or less of 1,4-pentadiene.

**[0055]** In certain other embodiments, another gaseous isoprene composition is provided. This composition comprises:

- a. isoprene in an amount between about 0.1% and 15% by volume;
- b. carbon dioxide in an amount between about 1% and 35% by volume; and,
- c. water in an amount that is greater than about 70% of its saturation amount

and wherein the gaseous isoprene composition comprises 1 part per million or less of C<sub>2</sub>-C<sub>5</sub> alkynes. In other embodiments, the gaseous isoprene composition comprises 1 part per million or less of each of C<sub>2</sub>-C<sub>5</sub> alkynes, cyclopentadiene, piperylene, and 1,4-pentadiene. In still other embodiments, the gaseous isoprene composition comprises saturated water. In yet other embodiments, the gaseous isoprene composition further comprises oxygen in an amount between about 8% and about 15% by volume or nitrogen in an amount between about 50% and 75% by volume or both.

**[0056]** The temperature of the above described gaseous compositions is at least 30 °C. In some cases, the temperature is between about 30 °C and about 60 °C. In other cases, the temperature is between about 30 °C and about 38°C.

**[0057]** The pressure of the above described gaseous compositions is between about 1 and about 2.5 atmospheres.

**[0058]** For some of the above described gaseous compositions, the temperature is between about 30 °C and about 35 °C and is at a pressure between about 1 and about 2.5 atmospheres.

#### ***Microbially Derived Liquid Isoprene Compositions***

**[0059]** Using the methods described herein, the gaseous isoprene compositions of the present invention can be further purified to liquid isoprene. Thus in another aspect of the invention, a liquid isoprene composition is provided that results from the inventive methods. The resulting liquid isoprene composition comprises at least 65% isoprene by weight and wherein the liquid isoprene composition comprises 1 part per million or less of C<sub>2</sub>-C<sub>5</sub> alkynes, cyclopentadiene, piperylene, and 1,4-pentadiene.

**[0060]** In some embodiments, the liquid isoprene composition comprises at least about 70%, 75%, 80%, 85%, and 90% isoprene by weight. In other embodiments, the liquid isoprene comprises at least about 95%, 96%, 97%, 98%, 99% and 99.5% isoprene by weight. In still other embodiments, the liquid isoprene composition comprises isoprene in an amount that is greater than about 99.5% by weight.

**[0061]** In other embodiments, the liquid isoprene composition further comprises carbon dioxide. In some embodiments, the carbon dioxide is present in an amount that is between about 0.01% by weight and about 1% by weight. In other embodiments, the carbon dioxide is present in an amount that is between about 0.05% and about 1% by weight. In further embodiments, the carbon dioxide is present in an amount that is between about 0.1% and about 1% by weight. In still further embodiments, the carbon dioxide is present in an amount that is between about 0.2% and about 0.7% by weight.

**[0062]** In other embodiments, the liquid isoprene composition further comprises nitrogen. In some embodiments, the nitrogen is present in an amount that is between about 0.001% by weight and about 1% by weight. In other embodiments, the carbon dioxide is present in an amount that is between about 0.01% and about 0.5% by weight. In further embodiments, the carbon dioxide is present in an amount that is between about 0.05% and about 0.5% by weight.

**[0063]** In other embodiments, the liquid isoprene composition further comprises ethanol. In some embodiments, the ethanol is present in an amount that is greater than about 0.01% by weight. In other embodiments, the ethanol is present in an amount that is greater than about 0.1%, 0.2%, 0.3%, 0.4%, 0.5%, 0.6%, 0.7%, 0.8%, and 0.9% by weight. In further embodiments, the ethanol is present in an amount that is greater than about 1% by weight.

**[0064]** In other embodiments, the liquid isoprene composition may comprise water in an amount that is less than about 1%, 0.5%, 0.1%, and 0.05% by weight. In other embodiments, the liquid isoprene composition may comprise water in an amount that is less than about 500 ppm, 250 ppm, 100 ppm, and 50 ppm by weight. In other embodiments, the liquid isoprene composition may comprise water in an amount, by weight, that is less than the level of detection.

**[0065]** In other embodiments, the microbial-derived liquid isoprene composition may comprise: isoprene in an amount of at least about 65% to an amount greater than about 99.5% by weight; carbon dioxide in an amount that is between about 0.01% and about 1% by weight; nitrogen in an amount that is between about 0.001% and about 1% by weight; ethanol in an amount greater than about 0.01% to an amount greater than about 1% by weight; water in an amount that is less than about 1% by weight to an amount that is less than the level of detection; C<sub>2</sub>-C<sub>5</sub> alkynes in an amount 1 part per million or less; cyclopentadiene in an amount 1 part per million or less; piperylene in an amount 1 part per million or less; and 1,4-pentadiene in an amount 1 part per million or less.

[0066] In certain other embodiments, another liquid isoprene composition is provided. This composition comprises:

- a. isoprene in an amount greater than about 65% by weight;
- b. ethanol in an amount greater than about 0.01% by weight; and,
- c. carbon dioxide in an amount between about 0.01% and about 1% by weight

wherein the liquid isoprene composition comprises 1 part per million or less of C<sub>2</sub>-C<sub>5</sub> alkynes, cyclopentadiene and piperylene C<sub>2</sub>-C<sub>5</sub> alkynes. In some embodiments, the isoprene is present in an amount greater than about 85% by weight. In still other embodiments, the isoprene is present in an amount greater than about 90% by weight. In further embodiments, the isoprene is present in an amount greater than about 90% by weight and ethanol is present in an amount that is between about 0.01% and about 1% by weight.

[0067] For some of the above described liquid isoprene compositions, the compositions have a temperature below -35 °C and a pressure between 0.01 and about 2 atmospheres. In other embodiments, the compositions have a temperature between -45 °C and about -85 °C and a pressure below about 1 atmosphere. In still further embodiments, the compositions have a temperature below -45 °C and a pressure below about 0.5 atmosphere.

### ***Microbial Host Cells***

[0068] Any microbial host cells capable of making isoprene can be used in the methods herein which would result in the inventive isoprene compositions.

[0069] Illustrative examples of suitable host cells are microbes that have been shown to make isoprene naturally. These strains include those described by U.S. Patent No. 5,849,970 and include: *Bacillus amyloliquiefaciens*; *Bacillus cereus*; *Bacillus subtilis* 6051; *Basillus substillis* 23059; *Bacillus subtilis* 23856; *Micrococcus luteus*; *Rhococcus rhodochrous*; *Acinetobacter calcoacetiucus*; *Agrobacterium rhizogenes*; *Escherichia coli*; *Erwinia herbicola*; *Pseudomonas aeruginosa*; and *Psuedomonas citronellolis*. However, microbes that make isoprene naturally are produced at extremely low levels.

[0070] Isoprene is made from isopentenyl pyrophosphate (IPP) by isoprene synthase. Because all microbial host cells are capable of making IPP, any host cells can be made to make isoprene by the insertion of isoprene synthase into its genome.

Illustrative examples of suitable nucleotide sequences include but are not limited to: (EF638224, *Populus alba*); (AJ294819, *Populus alba x Populus tremula*); (AM410988,

*Populus nigra*); (AY341431, *Populus tremuloides*); (EF147555, *Populus trichocarpa*); and (AY316691, *Pueraria montana var. lobata*). The addition of a heterologous isoprene synthase to a microbial host cells that make isoprene naturally will improve isoprene yields of natural isoprene producers as well.

[0071] Any suitable microbial host cell can be genetically modified to make isoprene. A genetically modified host cell is one in which nucleic acid molecules have been inserted, deleted or modified (*i.e.*, mutated; e.g., by insertion, deletion, substitution, and/or inversion of nucleotides), to produce isoprene. Illustrative examples of suitable host cells include any archae, bacterial, or eukaryotic cell. Examples of archae cells include, but are not limited to those belonging to the genera: *Aeropyrum*, *Archaeoglobus*, *Halobacterium*, *Methanococcus*, *Methanobacterium*, *Pyrococcus*, *Sulfolobus*, and *Thermoplasma*. Illustrative examples of archae species include but are not limited to: *Aeropyrum pernix*, *Archaeoglobus fulgidus*, *Methanococcus jannaschii*, *Methanobacterium thermoautotrophicum*, *Pyrococcus abyssi*, *Pyrococcus horikoshii*, *Thermoplasma acidophilum*, *Thermoplasma volcanium*.

[0072] Examples of bacterial cells include, but are not limited to those belonging to the genera: *Agrobacterium*, *Alicyclobacillus*, *Anabaena*, *Anacystis*, *Arthrobacter*, *Azobacter*, *Bacillus*, *Brevibacterium*, *Chromatium*, *Clostridium*, *Corynebacterium*, *Enterobacter*, *Erwinia*, *Escherichia*, *Lactobacillus*, *Lactococcus*, *Mesorhizobium*, *Methylobacterium*, *Microbacterium*, *Phormidium*, *Pseudomonas*, *Rhodobacter*, *Rhodopseudomonas*, *Rhodospirillum*, *Rhodococcus*, *Salmonella*, *Scenedesmun*, *Serratia*, *Shigella*, *Staphylococcus*, *Streptomyces*, *Synnecoccus*, and *Zymomonas*.

[0073] Illustrative examples of bacterial species include but are not limited to: *Bacillus subtilis*, *Bacillus amyloliquefacines*, *Brevibacterium ammoniagenes*, *Brevibacterium immariophilum*, *Clostridium beigerinckii*, *Enterobacter sakazakii*, *Escherichia coli*, *Lactococcus lactis*, *Mesorhizobium loti*, *Pseudomonas aeruginosa*, *Pseudomonas mevalonii*, *Pseudomonas pudica*, *Rhodobacter capsulatus*, *Rhodobacter sphaeroides*, *Rhodospirillum rubrum*, *Salmonella enterica*, *Salmonella typhi*, *Salmonella typhimurium*, *Shigella dysenteriae*, *Shigella flexneri*, *Shigella sonnei*, *Staphylococcus aureus*, and the like.

[0074] In general, if a bacterial host cell is used, a non-pathogenic strain is preferred. Illustrative examples of species with non-pathogenic strains include but are not limited to: *Bacillus subtilis*, *Escherichia coli*, *Lactibacillus acidophilus*, *Lactobacillus*

*helveticus*, *Pseudomonas aeruginosa*, *Pseudomonas mevalonii*, *Pseudomonas putida*, *Rhodobacter sphaeroides*, *Rhodobacter capsulatus*, *Rhodospirillum rubrum*, and the like.

[0075] Examples of eukaryotic cells include but are not limited to fungal cells. Examples of fungal cells include, but are not limited to those belonging to the genera: *Aspergillus*, *Candida*, *Chrysosporium*, *Cryptococcus*, *Fusarium*, *Kluyveromyces*, *Neotyphodium*, *Neurospora*, *Penicillium*, *Pichia*, *Saccharomyces*, *Trichoderma* and *Xanthophyllomyces* (formerly *Phaffia*).

[0076] Illustrative examples of eukaryotic species include but are not limited to: *Aspergillus nidulans*, *Aspergillus niger*, *Aspergillus oryzae*, *Candida albicans*, *Chrysosporium lucknowense*, *Fusarium graminearum*, *Fusarium venenatum*, *Kluyveromyces lactis*, *Neurospora crassa*, *Pichia angusta*, *Pichia finlandica*, *Pichia kodamae*, *Pichia membranaefaciens*, *Pichia methanolica*, *Pichia opuntiae*, *Pichia pastoris*, *Pichia pijperi*, *Pichia quercuum*, *Pichia salictaria*, *Pichia thermotolerans*, *Pichia trehalophila*, *Pichia stipitis*, *Streptomyces ambofaciens*, *Streptomyces aureofaciens*, *Streptomyces aureus*, *Saccaromyces bayanus*, *Saccaromyces boulardi*, *Saccharomyces cerevisiae*, *Streptomyces fungicidicus*, *Streptomyces griseochromogenes*, *Streptomyces griseus*, *Streptomyces lividans*, *Streptomyces olivogriseus*, *Streptomyces rameus*, *Streptomyces tanashiensis*, *Streptomyces vinaceus*, *Trichoderma reesei* and *Xanthophyllomyces dendrorhous* (formerly *Phaffia rhodozyma*).

[0077] In general, if a eukaryotic cell is used, a non-pathogenic strain is preferred. Illustrative examples of species with non-pathogenic strains include but are not limited to: *Fusarium graminearum*, *Fusarium venenatum*, *Pichia pastoris*, *Saccaromyces boulardi*, and *Saccaromyces cerevisiae*.

[0078] In some embodiments, the host cells of the present invention have been designated by the Food and Drug Administration as GRAS or Generally Regarded As Safe. Illustrative examples of such strains include: *Bacillus subtilis*, *Lactobacillus acidophilus*, *Lactobacillus helveticus*, and *Saccharomyces cerevisiae*.

[0079] In addition to the heterologous nucleic acid encoding an isoprene synthase, the microbial host cell can be further modified to increase isoprene yields. These modifications include but are not limited to the expression of one or more heterologous nucleic acid molecules encoding one or more enzymes in the mevalonate or DXP pathways.

**MEV Pathway**

[0080] A schematic representation of the MEV pathway is described in Figure 3. In general, the pathway comprises six steps.

[0081] In the first step, two molecules of acetyl-coenzyme A are enzymatically combined to form acetoacetyl-CoA. An enzyme known to catalyze this step is, for example, acetyl-CoA thiolase (also known as acetyl-CoA acetyltransferase). Illustrative examples of nucleotide sequences include but are not limited to the following GenBank accession numbers and the organism from which the sequences derived: (NC\_000913 REGION: 2324131..2325315; *Escherichia coli*), (D49362; *Paracoccus denitrificans*), and (L20428; *Saccharomyces cerevisiae*).

[0082] In the second step of the MEV pathway, acetoacetyl-CoA is enzymatically condensed with another molecule of acetyl-CoA to form 3-hydroxy-3-methylglutaryl-CoA (HMG-CoA). An enzyme known to catalyze this step is, for example, HMG-CoA synthase. Illustrative examples of nucleotide sequences include but are not limited to: (NC\_001145. complement 19061..20536; *Saccharomyces cerevisiae*), (X96617; *Saccharomyces cerevisiae*), (X83882; *Arabidopsis thaliana*), (AB037907; *Kitasatospora griseola*), (BT007302; *Homo sapiens*), and (NC\_002758, Locus tag SAV2546, GeneID 1122571; *Staphylococcus aureus*).

[0083] In the third step, HMG-CoA is enzymatically converted to mevalonate. An enzyme known to catalyze this step is, for example, HMG-CoA reductase. Illustrative examples of nucleotide sequences include but are not limited to: (NM\_206548; *Drosophila melanogaster*), (NC\_002758, Locus tag SAV2545, GeneID 1122570; *Staphylococcus aureus*), (NM\_204485; *Gallus gallus*), (AB015627; *Streptomyces sp.* KO 3988), (AF542543; *Nicotiana attenuata*), (AB037907; *Kitasatospora griseola*), (AX128213, providing the sequence encoding a truncated HMGR; *Saccharomyces cerevisiae*), and (NC\_001145: complement (115734..118898; *Saccharomyces cerevisiae*).

[0084] In the fourth step, mevalonate is enzymatically phosphorylated to form mevalonate 5-phosphate. An enzyme known to catalyze this step is, for example, mevalonate kinase. Illustrative examples of nucleotide sequences include but are not limited to: (L77688; *Arabidopsis thaliana*), and (X55875; *Saccharomyces cerevisiae*).

[0085] In the fifth step, a second phosphate group is enzymatically added to mevalonate 5-phosphate to form mevalonate 5-pyrophosphate. An enzyme known to catalyze this step is, for example, phosphomevalonate kinase. Illustrative examples of nucleotide sequences include but are not limited to: (AF429385; *Hevea brasiliensis*),

(NM\_006556; *Homo sapiens*), and (NC\_001145. complement 712315..713670; *Saccharomyces cerevisiae*).

**[0086]** In the sixth step, mevalonate 5-pyrophosphate is enzymatically converted into IPP. An enzyme known to catalyze this step is, for example, mevalonate pyrophosphate decarboxylase. Illustrative examples of nucleotide sequences include but are not limited to: (X97557; *Saccharomyces cerevisiae*), (AF290095; *Enterococcus faecium*), and (U49260; *Homo sapiens*).

#### ***DXP Pathway***

**[0087]** A schematic representation of the DXP pathway is described in Figure 4. In general, the DXP pathway comprises seven steps. In the first step, pyruvate is condensed with D-glyceraldehyde 3-phosphate to make 1-deoxy-D-xylulose-5-phosphate. An enzyme known to catalyze this step is, for example, 1-deoxy-D-xylulose-5-phosphate synthase. Illustrative examples of nucleotide sequences include but are not limited to: (AF035440; *Escherichia coli*), (NC\_002947, locus tag PP0527; *Pseudomonas putida* KT2440), (CP000026, locus tag SPA2301; *Salmonella enterica Paratyphi*, see ATCC 9150), (NC\_007493, locus tag RSP\_0254; *Rhodobacter sphaeroides* 2.4.1), (NC\_005296, locus tag RPA0952; *Rhodopseudomonas palustris* CGA009), (NC\_004556, locus tag PD1293; *Xylella fastidiosa Temecula1*), and (NC\_003076, locus tag AT5G11380; *Arabidopsis thaliana*).

**[0088]** In the second step, 1-deoxy-D-xylulose-5-phosphate is converted to 2C-methyl-D-erythritol-4-phosphate. An enzyme known to catalyze this step is, for example, 1-deoxy-D-xylulose-5-phosphate reductoisomerase. Illustrative examples of nucleotide sequences include but are not limited to: (AB013300; *Escherichia coli*), (AF148852; *Arabidopsis thaliana*), (NC\_002947, locus tag PP1597; *Pseudomonas putida* KT2440), (AL939124, locus tag SCO5694; *Streptomyces coelicolor* A3(2)), (NC\_007493, locus tag RSP\_2709; *Rhodobacter sphaeroides* 2.4.1), and (NC\_007492, locus tag Pfl\_1107; *Pseudomonas fluorescens* PfO-1).

**[0089]** In the third step, 2C-methyl-D-erythritol-4-phosphate is converted to 4-diphosphocytidyl-2C-methyl-D-erythritol. An enzyme known to catalyze this step is, for example, 4-diphosphocytidyl-2C-methyl-D-erythritol synthase. Illustrative examples of nucleotide sequences include but are not limited to: (AF230736; *Escherichia coli*), (NC\_007493, locus\_tag RSP\_2835; *Rhodobacter sphaeroides* 2.4.1), (NC\_003071,

locus\_tag AT2G02500; *Arabidopsis thaliana*), and (NC\_002947, locus\_tag PP1614; *Pseudomonas putida* KT2440).

**[0090]** In the fourth step, 4-diphosphocytidyl-2C-methyl-D-erythritol is converted to 4-diphosphocytidyl-2C-methyl-D-erythritol-2-phosphate. An enzyme known to catalyze this step is, for example, 4-diphosphocytidyl-2C-methyl-D-erythritol kinase. Illustrative examples of nucleotide sequences include but are not limited to: (AF216300; *Escherichia coli*) and (NC\_007493, locus\_tag RSP\_1779; *Rhodobacter sphaeroides* 2.4.1).

**[0091]** In the fifth step, 4-diphosphocytidyl-2C-methyl-D-erythritol-2-phosphate is converted to 2C-methyl-D-erythritol 2, 4-cyclodiphosphate. An enzyme known to catalyze this step is, for example, 2C-methyl-D-erythritol 2, 4-cyclodiphosphate synthase. Illustrative examples of nucleotide sequences include but are not limited to: (AF230738; *Escherichia coli*), (NC\_007493, locus\_tag RSP\_6071; *Rhodobacter sphaeroides* 2.4.1), and (NC\_002947, locus\_tag PP1618; *Pseudomonas putida* KT2440).

**[0092]** In the sixth step, 2C-methyl-D-erythritol 2, 4-cyclodiphosphate is converted to 1-hydroxy-2-methyl-2-(E)-butenyl-4-diphosphate. An enzyme known to catalyze this step is, for example, 1-hydroxy-2-methyl-2-(E)-butenyl-4-diphosphate synthase. Illustrative examples of nucleotide sequences include but are not limited to: (AY033515; *Escherichia coli*), (NC\_002947, locus\_tag PP0853; *Pseudomonas putida* KT2440), and (NC\_007493, locus\_tag RSP\_2982; *Rhodobacter sphaeroides* 2.4.1).

**[0093]** In the seventh step, 1-hydroxy-2-methyl-2-(E)-butenyl-4-diphosphate is converted into either IPP or its isomer, DMAPP. An enzyme known to catalyze this step is, for example, isopentyl/dimethylallyl diphosphate synthase. Illustrative examples of nucleotide sequences include but are not limited to: (AY062212; *Escherichia coli*) and (NC\_002947, locus\_tag PP0606; *Pseudomonas putida* KT2440).

**[0094]** In some embodiments, "cross talk" (or interference) between the host cell's own metabolic processes and those processes involved with the production of IPP as provided by the present invention are minimized or eliminated entirely. For example, cross talk is minimized or eliminated entirely when the host microorganism relies exclusively on the DXP pathway for synthesizing IPP, and a MEV pathway is introduced to provide additional IPP. Such host organisms would not be equipped to alter the expression of the MEV pathway enzymes or process the intermediates associated with the MEV pathway. Organisms that rely exclusively or predominately on the DXP pathway include, for example, *Escherichia coli*.

[0095] In some embodiments, the host cell produces IPP via the MEV pathway, either exclusively or in combination with the DXP pathway. In other embodiments, a host's DXP pathway is functionally disabled so that the host cell produces IPP exclusively through a heterologously introduced MEV pathway. The DXP pathway can be functionally disabled by disabling gene expression or inactivating the function of one or more of the naturally occurring DXP pathway enzymes.

[0096] In other embodiments, the host cell produces IPP via the DXP pathway, either exclusively or in combination with the MEV pathway. In other embodiments, a host's MEV pathway is functionally disabled so that the host cell produces IPP exclusively through a heterologously introduced DXP pathway. The MEV pathway can be functionally disabled by disabling gene expression or inactivating the function of one or more of the naturally occurring MEV pathway enzymes.

[0097] Methods for genetically modifying host organisms and their cultivation have been previously described. Illustrative examples include U. S. Patent Nos. 6,689,593; 7,172,886; 7,183,089; U.S. Patent Publication Nos. US 2008/0171378; US 2008/0274523; and US 2009/0203102 and PCT Publication Nos. WO 2007/139924; WO 2009/076676; WO 2010/003007; and WO 2009/132220, which are all incorporated herein by reference in their entirety. Additional methods for modifying host organisms to make isoprene are also provided in the Examples below.

#### ***Purification and Recovery of Microbially Derived Gaseous Isoprene***

[0098] The present invention provides methods for handling a gaseous isoprene composition produced from the microbial host cells. When the resulting gaseous isoprene compositions or the above-described gaseous isoprene compositions are treated with the following methods, then the results are the liquid isoprene compositions described above.

[0099] In one aspect, a system for purifying isoprene without extractive distillation is provided. Extractive distillation is defined as distillation in the presence of a solvent that forms no azeotrope with other components in the mixture and is used to separate mixtures that cannot be separated by simple distillation because the volatility of at least two of the components in the mixture is nearly the same, causing them to evaporate at nearly the same temperature at a similar rate. Generally miscible, high boiling, and relatively non-volatile, the extraction distillation solvent interacts differently with the components in the mixture enabling the mixture to be separated by normal distillation. Extractive distillation is almost always used in purifying petroleum-derived isoprene.

Because extractive distillation requires special equipment and is inherently energy intensive, it is substantial part of the costs associated with making isoprene. In many embodiments of the present invention, the resulting isoprene compositions do not include trace amounts of an extraction distillation solvent because extractive distillation solvents are not used. Illustrative examples of such solvents include but are not limited to acetonitrile and dimethylformamide.

**[00100]** Figure 1 is a schematic representation of an exemplary separation system. Host cells are cultivated in a bioreactor and the isoprene produced by the cells vaporizes and forms a gaseous isoprene composition (1). Optionally, the gaseous isoprene composition may pass through a drying process to remove some of the water vapor (not shown). The gaseous isoprene composition (1) is directed to a first chiller **102** which cools the gaseous isoprene composition to a temperature between about 10 °C and about -15 °C. The cooled gaseous isoprene composition (7) then passes through drum **104**, where the water vapor in the gaseous isoprene composition condenses into a liquid and discharged from the process (5). The exiting gaseous isoprene composition (8) may pass through a drying process to remove any remaining water (not shown). The gaseous isoprene composition (8) is directed to a second chiller **106** further cooling the composition to a temperature below -35 °C. The resulting liquid isoprene composition (9) flows to drum **108**. Optionally, the bottom stream (10) from drum **108** may then be passed to nitrogen stripper **110** while the top stream (11) is recycled back to the first chiller **102** to assist in (or to serve as the refrigerant for) chilling the incoming gaseous isoprene (1) and then exiting a by-product stream (6). Substantially pure nitrogen (2) is introduced into nitrogen stripper **110** whereby the liquid isoprene composition (3) is recovered and the by-product nitrogen gas (4) can be discharged or recovered in a subsequent recovery step (not shown).

**[00101]** In another embodiment, the system comprises:

- a. a bioreactor capable of culturing a plurality of host cells, preferably the bioreactor has a capacity of greater than 100 liters;
- b. a first chiller and flash drum operably connected to the overhead stream of the bioreactor, the first chiller preferably capable of operating in a temperature range of between 10°C and -15°C;
- c. a second chiller and flash drum operably connected to the overhead stream exiting from the first chiller and flash drum, the second chiller preferably

capable of operating in a temperature below  $-35^{\circ}\text{C}$ , for example between about  $-65^{\circ}\text{C}$  and about  $-85^{\circ}\text{C}$ ;

- d. optionally, the exiting overhead stream from the second chiller and flash drum may be operably connected to the inlet of the refrigerant or cooling stream of the first chiller; and
- e. optionally, the condensed stream exiting from the second chiller and flash drum may be operably connected to a nitrogen stripper.

**[00102]** In another aspect, method for recovering isoprene using such a system is provided. The method comprises:

- a. obtaining a first gaseous composition comprising isoprene and water wherein the gaseous composition comprises 1 part per million or less of  $\text{C}_2$ - $\text{C}_5$  alkynes;
- b. flowing the first gaseous composition through a first chiller wherein the first chiller has a temperature of between about  $10^{\circ}\text{C}$  and about  $-15^{\circ}\text{C}$  thereby resulting in a second gaseous composition and wherein the second gaseous composition comprises less water than the first gaseous composition, for example the second gas composition comprises about 3% by weight or less of water;
- c. flowing the second gaseous composition through a second chiller wherein the second chiller has a temperature below  $-35^{\circ}\text{C}$ ; and
- d. collecting the resulting liquid isoprene composition.

**[00103]** In other embodiments, the method for recovering isoprene comprises reducing the water content present in the first gaseous composition by flowing the first gaseous composition through a first chiller wherein the first chiller has a temperature of between about  $10^{\circ}\text{C}$  and about  $-15^{\circ}\text{C}$  thereby resulting in a second gaseous composition and wherein the second gaseous composition comprises less water than the first gaseous composition, for example the second gas composition comprises less than about 3% by weight of water. In other embodiments, the second gas composition comprises less than about 2% by weight of water, less than 1%, 0.5%, 0.1%, and 0.05% by weight. In other embodiments, the second gas composition comprises less than about 500 ppm by weight of water, less than 250 ppm, 100 ppm and 50 ppm by weight.

**[00104]** In another aspect, method for recovering isoprene using such a system is provided. The method comprises:

- a. obtaining a first gaseous composition comprising isoprene and water wherein the gaseous composition comprises 1 part per million or less of C<sub>2</sub>-C<sub>5</sub> alkynes;
- b. flowing the first gaseous composition through a first chiller wherein the first chiller has a temperature of between about 10 °C and about -15 °C thereby resulting in a second gaseous composition and wherein the second gaseous composition comprises less water than the first gaseous composition, for example the second gas composition comprises about 3% by weight or less of water;
- c. flowing the second gaseous composition through a second chiller wherein the second chiller has a temperature below -35 °C thereby resulting in a liquid isoprene composition, wherein the liquid isoprene composition comprises less of one or more of the following components than the second gaseous composition, comprising:
  - i. water in amount less than about 1% by weight or less;
  - ii. carbon dioxide in amount less than 1% by weight;
  - iii. nitrogen in amount less than 1% by weight; and
- d. collecting the resulting liquid isoprene composition.

**[00105]** In some embodiments, the method further comprises nitrogen stripping the liquid isoprene composition. This nitrogen stripping may be accomplished by any suitable method including passing a substantially pure nitrogen stream through the liquid isoprene enriched composition. This nitrogen stream serves to further remove dissolved gases (such, as for example oxygen, carbon dioxide, nitrogen, and argon) and or/remaining water. In other embodiments, nitrogen stripping of the liquid isoprene composition may comprise removing: dissolved oxygen to levels less than about 1%, 0.5%, 0.1%, and 0.05% by weight; dissolved carbon dioxide to levels less than about 1%, 0.5%, 0.1%, and 0.05% by weight; dissolved nitrogen to levels less than about 1%, 0.5%, 0.1%, and 0.05% by weight; dissolved argon to levels less than about 1%, 0.5%, 0.1%, and 0.05% by weight; and any remaining water to levels less than about 1%, 0.5%, 0.1%, 0.05% by weight to levels lower than the level of detection.

**[00106]** In some embodiments, the method further comprises extracting hydrocarbon impurities at some point in the purifying isoprene process. This hydrocarbon extraction may be accomplished by passing a portion or all of the first gaseous composition, second gaseous composition and/or the liquid isoprene composition over or

through a modified zeolite membrane and/or molecular sieve. The zeolite membrane and/or molecular sieves may be modified to selectively adsorb either isoprene and not the other hydrocarbons present in the treated composition or vice versa (adsorb other hydrocarbons in the treated composition and not isoprene). In some embodiments, the zeolites and/or molecular sieves are modified by carbonization to provide the selected adsorbitivity. In some embodiments, the zeolites may be L-type, Y-type, ZSM-5, and/or beta-type. In some embodiments a method for enhancing the selectivity of a zeolite by controlled carbonization as detailed in U.S. Patent 7,041,616, which is hereby incorporated in its entirety by reference, may be used.

**[00107]** In other embodiments, the first gaseous composition further comprises carbon dioxide. In still other embodiments, the first gaseous composition further comprises oxygen. In still other embodiments, the first gaseous composition further comprises nitrogen.

**[00108]** In other embodiments, the first gaseous composition comprises 1 part per million or less of C<sub>2</sub>-C<sub>5</sub> alkynes and cyclopentadiene, In further embodiments, the first gaseous composition further comprises 1 part per million or less of C<sub>2</sub>-C<sub>5</sub> alkynes and piperylene. In still other embodiments, the first gaseous composition comprises 1 part per million or less of C<sub>2</sub>-C<sub>5</sub> alkynes and 1,4-pentadiene. In still other embodiments, the first gaseous composition comprises 1 part per million or less of C<sub>2</sub>-C<sub>5</sub> alkynes, cyclopentadiene, piperylene, and 1,4-pentadiene.

**[00109]** In other embodiments, the first gaseous composition is flowed through a drier prior to flowing through the first chiller. In still other embodiments, the first gaseous composition is flowed through a drier after flowing through the first chiller but prior to flowing through the second chiller.

**[00110]** In other embodiments, the first chiller has a temperature of about -5°C. In other embodiments, the first chiller is cooled using a propylene refrigeration system. In still other embodiments, the first chiller is cooled using an ammonium refrigeration system.

**[00111]** In other embodiments, the second chiller has a temperature less than about -50°C. In other embodiments, the second chiller has a temperature of about -60°C to about -85°C. In still other embodiments, the second chiller has a temperature of less than about -65°C. In still other embodiments, the second chiller has a temperature between about -35°C and about -85°C.

**[00112]** In other embodiments, the liquid isoprene composition comprises at least about 70%, 75%, 80%, 85%, and 90% isoprene by weight. In other embodiments, the liquid isoprene comprises at least about 95%, 96%, 97%, 98%, 99% and 99.5% isoprene by weight. In still other embodiments, the liquid isoprene composition comprises isoprene in an amount that is greater than about 99.5% by weight.

**[00113]** In other embodiments, the second chiller is cooled using an ethylene refrigeration system.

**[00114]** In another aspect, another method is provided. The method comprises:

- a. culturing a plurality of host cells capable of making isoprene;
- b. forming a first gaseous composition comprising isoprene and water wherein the water is present in an amount greater than about 70% of its saturation amount;
- c. subjecting the first gaseous composition to a first cooling step whereby substantially all of the water is removed from the first gaseous composition resulting a second gaseous composition;
- d. subjecting the second gaseous composition to a second cooling step whereby a liquid isoprene composition is collected.

**[00115]** In some embodiments, the method further comprises nitrogen stripping the liquid isoprene composition.

**[00116]** In other embodiments, the first gaseous composition further comprises carbon dioxide. In still other embodiments, the first gaseous composition further comprises oxygen. In still other embodiments, the first gaseous composition further comprises nitrogen.

**[00117]** In other embodiments, the first gaseous composition comprises 1 part per million or less of C<sub>2</sub>-C<sub>5</sub> alkynes and cyclopentadiene. In further embodiments, the first gaseous composition further comprises 1 part per million or less of C<sub>2</sub>-C<sub>5</sub> alkynes and piperylene. In still other embodiments, the first gaseous composition comprises 1 part per million or less of C<sub>2</sub>-C<sub>5</sub> alkynes and 1,4-pentadiene. In still other embodiments, the first gaseous composition comprises 1 part per million or less of C<sub>2</sub>-C<sub>5</sub> alkynes, cyclopentadiene, piperylene, and 1,4-pentadiene.

**[00118]** In other embodiments, the first gaseous composition is subjected through a drier prior to the first cooling step. In still other embodiments, the first gaseous composition is subjected through a drier after the first cooling step but prior to the second cooling step.

[00119] In other embodiments, the first cooling step cools the first gaseous isoprene composition to a temperature between about 10 °C and about -15 °C, between about 10 °C and about -10 °C, about 5 °C and about -5 °C, and about 5 °C and about -10 °C.

[00120] In other embodiments, the first cooling step uses a propylene refrigeration system. In still other embodiments, the first cooling step uses chiller an ammonium refrigeration system.

[00121] In other embodiments, the second cooling step cools the second gaseous isoprene composition to a temperature less than -35 °C. In other embodiments, the second cooling step cools the second gaseous isoprene composition to a temperature less than about -50 °C. In still other embodiments, the second cooling step cools the second gaseous isoprene composition to a temperature about -60 °C to about -85 °C. In still further embodiments, the second cooling step cools the second gaseous isoprene composition to a temperature of less than about -65 °C.

[00122] In other embodiments, the second cooling step uses an ethylene refrigeration system.

[00123] In other embodiments, the liquid isoprene composition comprises at least about 70%, 75%, 80%, 85%, and 90% isoprene by weight. In other embodiments, the liquid isoprene comprises at least about 95%, 96%, 97%, 98%, 99% and 99.5% isoprene by weight. In still other embodiments, the liquid isoprene composition comprises isoprene in an amount that is greater than about 99.5% by weight.

[00124] In other embodiments, the host cells are selected from the genus *Bacillus*, *Escherichia* or *Acinetobacter*. In still other embodiments, the host cells are *Escherichia coli*. In further embodiments, the host cells are yeast. In still further embodiments, the host cells are *Saccharomyces cerevisiae*.

[00125] In another aspect, another method is provided. The method comprises:

- a. contacting a plurality of host cells capable of making isoprene in an aqueous medium wherein the aqueous medium is in contact with an immiscible organic liquid and the aqueous medium, the host cells, and the immiscible organic liquid is in a closed vessel; and
- b. culturing the host cells in the aqueous medium whereby the host cells make isoprene and the isoprene is captured in the immiscible organic liquid.

[00126] In some embodiments, the method further comprises separating the immiscible organic liquid from the aqueous medium and separating the isoprene from the immiscible organic liquid.

[00127] In other embodiments, the immiscible organic liquid is selected from butyl acetate, ethyl acetate, isopropyl myristate, methyl isobutyl ketone, methyl oleate, and toluene. In certain embodiments, the solvent is butyl acetate. In other embodiments, the immiscible organic liquid is isopropyl myristate.

[00128] In other embodiments, the isoprene is separated from the immiscible organic liquid by heating the immiscible organic liquid to a temperature above 34 °C.

[00129] The resulting gaseous isoprene composition can then be further purified using the methods described above.

[00130] In another aspect, a system for making microbial isoprene is provided. An illustrative example of such a system is shown in Figure 2. Bioreactor **202** is a closed system where host cells capable of making isoprene are cultivated in an aqueous medium and with an immiscible organic liquid on top of the aqueous medium. Because bioreactor **202** is a closed system, the isoprene produced by the host cells is captured by the immiscible organic liquid. The isoprene-enriched immiscible organic liquid (A) may then be directed to any suitable gas-liquid separation method. In this example, the isoprene-enriched immiscible organic liquid is directed to a heater **204** which volatilizes the isoprene into a gaseous isoprene composition (1). This gaseous isoprene composition (1) can then be further purified using the systems and methods described above. The immiscible organic liquid (B) can optionally be recycled and used in subsequent bioreactions to make isoprene.

[00131] In another embodiment, the system comprises:

- a. a closed vessel;
- b. an aqueous medium, within the vessel, forming a first phase;
- c. a plurality of host cells, within the aqueous medium, capable of making isoprene; and,
- d. a liquid organic second phase, capable of capturing the isoprene made by the host cells, in contact with the first phase.

[00132] In some embodiments, the immiscible organic liquid is selected from butyl acetate, ethyl acetate, isopropyl myristate, methyl isobutyl ketone, methyl oleate, and toluene. In certain embodiments, the solvent is butyl acetate. In other embodiments, the immiscible organic liquid is isopropyl myristate.

[00133] In other embodiments, the host cells are selected from the genus *Bacillus*, *Escherichia* or *Acinetobacter*. In still other embodiments, the host cells are

*Escherichia coli*. In further embodiments, the host cells are yeast. In still further embodiments, the host cells are *Saccharomyces cerevisiae*.

### EXAMPLES

[00134] The practice of the present invention can employ, unless otherwise indicated, conventional techniques of the biosynthetic industry and the like, which are within the skill of the art. To the extent such techniques are not described fully herein, one can find ample reference to them in the scientific literature.

[00135] In the following examples, efforts have been made to ensure accuracy with respect to numbers used (for example, amounts, temperature, and so on), but variation and deviation can be accommodated, and in the event a clerical error in the numbers reported herein exists, one of ordinary skill in the arts to which this invention pertains can deduce the correct amount in view of the remaining disclosure herein. Unless indicated otherwise, temperature is reported in degrees Celsius, and pressure is at or near atmospheric pressure at sea level. All reagents, unless otherwise indicated, were obtained commercially. The following examples are intended for illustrative purposes only and do not limit in any way the scope of the present invention.

#### Example 1

[00136] This example describes methods for detecting isoprene trapped in an immiscible organic liquid in a closed fermentation system.

[00137] In this example, isopropyl myristate (IPM) and solutions of IPM spiked with 103 mg/L, 10.3 mg/L and 0 mg/L isoprene were prepared and stored in 100 ml capped media bottles.

[00138] 125 ml unbaffled flasks with screw caps/septa were set up in triplicate. The flasks contained 40 ml medium (Yeast Nitrogen Base media with 4% galactose, 0.2% glucose, Leu) inoculated with overnight yeast culture (which does not make isoprene) grown to an OD = 0.05 with 8 ml of IPM solutions with the various concentrations of isoprene. The sealed flasks were incubated for 72 hours at 30 °C and 200 rpm.

[00139] Post-incubation, the IPM overlay was phase-separated by manual transfer to primary GC vials, then transferred to secondary GC vials and run undiluted on GC-FID. In addition to samples from flasks, the original solutions of 103 and 10.3 mg/L isoprene in IPM (NOT shaken for 72 hours at 200 rpm, 30 °C) were also analyzed.

[00140] As shown by Figure 5, over 90% of the spiked isoprene was recovered from the IPM layer. Cell growth for cultures with 103, 10.3, and 0 mg/L isoprene in the IPM layer was indistinguishable.

#### Example 2

[00141] This example describes methods for making nucleic acids for expressing in *Saccharomyces cerevisiae* heterologous isoprene synthases.

[00142] Genomic DNA was isolated from *Saccharomyces cerevisiae* strains Y002 (CEN.PK2 background MATA ura3-52 trp1-289 leu2-3,112 his3 $\Delta$ 1 MAL2-8C SUC2) (van Dijken et al. (2000) Enzyme and Microbial Technology 26:706-714), Y007 (S288C background MATA trp1 $\Delta$ 63) (ATCC number 200873), Y051 (S288C background), and EG123 (ATCC number 204278). The strains were grown overnight in liquid medium containing 1% Yeast extract, 2% Bacto-peptone, and 2% Dextrose (YPD medium). Cells were isolated from 10 mL liquid cultures by centrifugation at 3,100 rpm, washing of cell pellets in 10 mL ultra-pure water, and re-centrifugation. Genomic DNA was extracted using the Y-DER yeast DNA extraction kit (Pierce Biotechnologies, Rockford, IL) as per manufacturer's suggested protocol. Extracted genomic DNA was re-suspended in 100  $\mu$ L 10 mM Tris-Cl, pH 8.5, and OD<sub>260/280</sub> readings were taken on a ND-1000 spectrophotometer (NanoDrop Technologies, Wilmington, DE) to determine genomic DNA concentration and purity.

[00143] DNA amplification by Polymerase Chain Reaction (PCR) was done in an Applied Biosystems 2720 Thermocycler (Applied Biosystems Inc, Foster City, CA) using the Phusion High Fidelity DNA Polymerase system (Finnzymes OY, Espoo, Finland) as per manufacturer's suggested protocol. Upon the completion of a PCR amplification of a DNA fragment that was to be inserted into the pCR $\text{\textcircled{R}}$ 4Blunt-TOPO vector (Invitrogen, Carlsbad, CA), A nucleotide overhangs were created by adding 1  $\mu$ L of Qiagen Taq Polymerase (Qiagen, Valencia, CA) to the reaction mixture and performing an additional 10 minute, 72°C PCR extension step, followed by cooling to 4°C. Upon completion of a PCR amplification, 8  $\mu$ L of a 50% glycerol solution was added to the reaction mix.

[00144] Agarose gel electrophoresis was performed using a 1% TBE (0.89 M Tris, 0.89 M Boric acid, 0.02 M EDTA sodium salt) agarose gel containing 0.5  $\mu$ g/mL ethidium bromide, at 120 V, 400 mA for 30 minutes. DNA bands were visualized using ultraviolet light. DNA bands were excised from the gel with a sterile razor blade, and the excised DNA was gel purified using the Zymoclean Gel DNA Recovery Kit (Zymo Research,

Orange, CA) according to manufacturer's suggested protocols. The purified DNA was eluted into 10 uL ultra-pure water, and OD<sub>260/280</sub> readings were taken on a ND-1000 spectrophotometer to determine DNA concentration and purity.

**[00145]** Ligations were performed using 100-500 µg of purified PCR product and High Concentration T4 DNA Ligase (New England Biolabs, Ipswich, MA) as per manufacturer's suggested protocol. For plasmid propagation, ligated constructs were transformed into *Escherichia coli* DH5α chemically competent cells (Invitrogen, Carlsbad, CA) as per manufacturer's suggested protocol. Positive transformants were selected on solid media containing 1.5% Bacto Agar, 1% Tryptone, 0.5% Yeast Extract, 1% NaCl, and an appropriate antibiotic. Isolated transformants were grown for 16 hours in liquid LB medium containing 50 µg/mL carbenicillin or kanamycin antibiotic at 37°C, and plasmid was isolated and purified using a QIAprep Spin Miniprep kit (Qiagen, Valencia, CA) as per manufacturer's suggested protocol. Constructs were verified by performing diagnostic restriction enzyme digestions, resolving DNA fragments on an agarose gel, and visualizing the bands using ultraviolet light. Select constructs were also verified by DNA sequencing, which was done by Elim Biopharmaceuticals Inc. (Hayward, CA).

**[00146]** Expression plasmid pAM353 was generated by inserting a nucleotide sequence encoding a β-farnesene synthase into the pRS425-Gal1 vector (Mumberg et. al. (1994) *Nucl. Acids. Res.* 22(25): 5767-5768). The nucleotide sequence insert was generated synthetically, using as a template the coding sequence of the β-farnesene synthase gene of *Artemisia annua* (GenBank accession number AY835398) codon-optimized for expression in *Saccharomyces cerevisiae* (SEQ ID NO: 1). The synthetically generated nucleotide sequence was flanked by 5' *Bam*HI and 3' *Xho*I restriction sites, and could thus be cloned into compatible restriction sites of a cloning vector such as a standard pUC or pACYC origin vector. The synthetically generated nucleotide sequence was isolated by digesting to completion the construct using *Bam*HI and *Xho*I restriction endonucleases. The reaction mixture was resolved by gel electrophoresis, the approximately 1.7 kb DNA fragment comprising the β-farnesene synthase coding sequence was gel purified, and the isolated DNA fragment was ligated into the *Bam*HI *Xho*I restriction site of the pRS425-Gal1 vector, yielding expression plasmid pAM353.

**[00147]** Expression plasmid pAM404 was generated by inserting a nucleotide sequence encoding the β-farnesene synthase of *Artemisia annua* (GenBank accession number AY835398) codon-optimized for expression in *Saccharomyces cerevisiae* into vector pAM178 (SEQ ID NO: 2). The nucleotide sequence encoding the β-farnesene

synthase was PCR amplified from pAM353 using primers 52-84 pAM326 BamHI (SEQ ID NO: 21) and 52-84 pAM326 NheI (SEQ ID NO: 22). The resulting PCR product was digested to completion using *BamHI* and *NheI* restriction endonucleases, the reaction mixture was resolved by gel electrophoresis, the approximately 1.7 kb DNA fragment comprising the  $\beta$ -farnesene synthase coding sequence was gel purified, and the isolated DNA fragment was ligated into the *BamHI NheI* restriction site of vector pAM178, yielding expression plasmid pAM404.

**[00148]** Plasmid Genetrix2080 was generated by inserting a nucleotide sequence encoding an isoprene synthase into vector pUC19. The insert was generated synthetically as two approximately equal sized DNA fragments, fragment 2080\_1 (SEQ ID NO: 3) and fragment 2080\_2 (SEQ ID NO: 4), using as a template the coding sequence of the isoprene synthase gene of *Kudzu* codon-optimized for expression in *Saccharomyces cerevisiae*. Each DNA fragment was flanked by *LguI* restriction sites, and comprised a 40 base pair overlapping sequence at one end. The synthetically generated DNA fragments were blunt ligated into the *SmaI* restriction site of the pUC19 cloning vector, from which the two inserts were excised again by digesting to completion 500  $\mu$ g of the construct using *LguI* restriction endonuclease (Fermentas, Glen Burnie, MD). The restriction endonuclease was heat inactivated for 20 minutes at 65°C, and the DNA fragments were stitched together by a first round of PCR amplification (one cycle of denature at 98°C for 2 minutes; 5 cycles of denature at 98°C for 30 seconds and anneal/extend at 72°C for 30 seconds per kilobase PCR product; no primers were used). Samples were placed on ice, 0.5  $\mu$ M of each terminal primer TRIX\_L\_494 (SEQ ID NO: 79) and TRIX\_L\_495 (SEQ ID NO: 80) were added to the reaction mixture, and a second round of PCR amplification was performed (one cycle of denature at 98°C for 2 minutes; 35 rounds of denature at 98°C for 12 seconds and anneal/extend at 72°C for 20 seconds per kilobase PCR product; one cycle of final extend at 72°C for 7 minutes; and a final hold at 4°C). The reaction mixture was resolved by gel electrophoresis, the assembled DNA fragment was gel purified, treated with T4 polynucleotide kinase (PNK) (New England Biolabs, Ipswich, MA), and blunt ligated into the *SmaI* restriction site of vector pUC19, yielding plasmid Genetrix2080.

**[00149]** Plasmid Genetrix2081 was generated by inserting a nucleotide sequence encoding an isoprene synthase into vector pUC19. The insert was generated synthetically as two approximately equal sized DNA fragments, fragment 2081\_1 (SEQ ID NO: 5) and fragment 2081\_2 (SEQ ID NO: 6), using as a template the coding sequence of the isoprene synthase gene of *Populus nigra* codon-optimized for expression in *Saccharomyces*

*cerevisiae*. Each DNA fragment was flanked by *LguI* restriction sites, and comprised a 30 base pair overlapping sequence at one end. The synthetically generated DNA fragments were blunt ligated into the *SmaI* restriction site of the pUC19 cloning vector, from which the two inserts were excised again by digesting to completion 500 µg of the construct using *LguI* restriction endonuclease (Fermentas, Glen Burnie, MD). The restriction endonuclease was heat inactivated for 20 minutes at 65°C, and the DNA fragments were stitched together by a first round of PCR amplification (one cycle of denature at 98°C for 2 minutes; 5 cycles of denature at 98°C for 30 seconds and anneal/extend at 72°C for 30 seconds per kilobase PCR product; no primers were used). Samples were placed on ice, 0.5 µM of each terminal primer TRIX\_L\_497 (SEQ ID NO: 81) and TRIX\_L\_498 (SEQ ID NO: 82) were added to the reaction mixture, and a second round of PCR amplification was performed (one cycle of denature at 98°C for 2 minutes; 35 rounds of denature at 98°C for 12 seconds and anneal/extend at 72°C for 20 seconds per kilobase PCR product; one cycle of final extend at 72°C for 7 minutes; and a final hold at 4°C). The reaction mixture was resolved by gel electrophoresis, the assembled DNA fragment was gel purified, treated with T4 polynucleotide kinase (PNK) (New England Biolabs, Ipswich, MA), and blunt ligated into the *SmaI* restriction site of vector pUC19, yielding plasmid Genetrix2081.

[00150] Plasmid Genetrix2082 was generated by inserting a nucleotide sequence encoding an isoprene synthase into vector pUC19. The insert was generated synthetically as two approximately equal sized DNA fragments, fragment 2082\_1 (SEQ ID NO: 7) and fragment 2082\_2 (SEQ ID NO: 8), using as a template the coding sequence of the isoprene synthase gene of *Populus alba x Populus tremula* codon-optimized for expression in *Saccharomyces cerevisiae*. Each DNA fragment was flanked by *LguI* restriction sites, and comprised a 40 base pair overlapping sequence at one end. The synthetically generated DNA fragments were blunt ligated into the *SmaI* restriction site of the pUC19 cloning vector, from which the two inserts were excised again by digesting to completion 500 µg of the construct using *LguI* restriction endonuclease (Fermentas, Glen Burnie, MD). The restriction endonuclease was heat inactivated for 20 minutes at 65°C, and the DNA fragments were stitched together by a first round of PCR amplification (one cycle of denature at 98°C for 2 minutes; 5 cycles of denature at 98°C for 30 seconds and anneal/extend at 72°C for 30 seconds per kilobase PCR product; no primers were used). Samples were placed on ice, 0.5 µM of each terminal primer TRIX\_L\_500 (SEQ ID NO: 83) and TRIX\_L\_501 (SEQ ID NO: 84) were added to the reaction mixture, and a second

round of PCR amplification was performed (one cycle of denature at 98°C for 2 minutes; 35 rounds of denature at 98°C for 12 seconds and anneal/extend at 72°C for 20 seconds per kilobase PCR product; one cycle of final extend at 72°C for 7 minutes; and a final hold at 4°C). The reaction mixture was resolved by gel electrophoresis, the assembled DNA fragment was gel purified, treated with T4 polynucleotide kinase (PNK) (New England Biolabs, Ipswich, MA), and blunt ligated into the *SmaI* restriction site of vector pUC19, yielding plasmid Genetrix2082.

**[00151]** Expression plasmid pAM1547 was generated by replacing the  $\beta$ -farnesene synthase coding sequence of expression plasmid pAM404 with the isoprene synthase coding sequence of plasmid Genetrix2080. DNA fragment IS2080 was generated by PCR amplifying plasmid Genetrix2080 using primers YD-198-70A (SEQ ID NO: 85) and YD-198-70B (SEQ ID NO: 86), digesting the PCR product to completion using restriction endonucleases *BamHI* and *NheI*, resolving the reaction mixture by gel electrophoresis, and gel purifying the approximately 1.8 kb DNA fragment comprising the isoprene synthase coding sequence. Expression plasmid pAM404 was digested to completion using restriction endonucleases *BamHI* and *NheI*, the reaction mixture was resolved by gel electrophoresis, the approximately 7.3 kb vector backbone (lacking the  $\beta$ -farnesene synthase coding sequence) was gel purified, and the purified vector backbone was ligated with DNA fragment IS2080, yielding pAM1547 (see Figure 6 for a plasmid map).

**[00152]** Expression plasmid pAM1548 was generated by replacing the  $\beta$ -farnesene synthase coding sequence of expression plasmid pAM404 with a truncated version of the isoprene synthase coding sequence of plasmid Genetrix2080. DNA fragment IS2080T was generated by PCR amplifying plasmid Genetrix2080 using primers YD-198-70B (SEQ ID NO: 86) and YD-198-70G (SEQ ID NO: 91), digesting the PCR product to completion using restriction endonucleases *BamHI* and *NheI*, resolving the reaction mixture by gel electrophoresis, and gel purifying the approximately 1.65 kb DNA fragment comprising the truncated isoprene synthase coding sequence. pAM404 was digested to completion using restriction endonucleases *BamHI* and *NheI*, the reaction mixture was resolved by gel electrophoresis, the approximately 7.3 kb backbone (lacking the  $\beta$ -farnesene synthase coding sequence) was gel purified, and the purified vector backbone was ligated with the amplified DNA fragment IS2080T, yielding pAM1548.

**[00153]** Expression plasmid pAM1549 was generated by replacing the  $\beta$ -farnesene synthase coding sequence of expression plasmid pAM404 with the isoprene synthase coding sequence of plasmid Genetrix2081. DNA fragment IS2081 was generated by PCR

amplifying plasmid Genetrix2081 using primers YD-198-70C (SEQ ID NO: 87) and YD-198-70D (SEQ ID NO: 88), digesting the PCR product to completion using restriction endonucleases *BamHI* and *NheI*, resolving the reaction mixture by gel electrophoresis, and gel purifying the approximately 1.8 kb DNA fragment comprising the isoprene synthase coding sequence. Expression plasmid pAM404 was digested to completion using restriction endonucleases *BamHI* and *NheI*, the reaction mixture was resolved by gel electrophoresis, the approximately 7.3 kb vector backbone (lacking the  $\beta$ -farnesene synthase coding sequence) was gel purified, and the purified vector backbone was ligated with DNA fragment IS2081, yielding pAM1549.

**[00154]** Expression plasmid pAM1550 was generated by replacing the  $\beta$ -farnesene synthase coding sequence of expression plasmid pAM404 with a truncated version of the isoprene synthase coding sequence of plasmid Genetrix2081. DNA fragment IS2081T was generated by PCR amplifying plasmid Genetrix2081 using primers YD-198-70D (SEQ ID NO: 88) and YD-198-70H (SEQ ID NO: 92), digesting the PCR product to completion using restriction endonucleases *BamHI* and *NheI*, resolving the reaction mixture by gel electrophoresis, and gel purifying the approximately 1.6 kb DNA fragment comprising the truncated isoprene synthase coding sequence. Expression plasmid pAM404 was digested to completion using restriction endonucleases *BamHI* and *NheI*, the reaction mixture was resolved by gel electrophoresis, the approximately 7.3 kb vector backbone (lacking the  $\beta$ -farnesene synthase coding sequence) was gel purified, and the purified vector backbone was ligated with DNA fragment IS2081T, yielding pAM1550.

**[00155]** Expression plasmid pAM1551 was generated by replacing the  $\beta$ -farnesene synthase coding sequence of expression plasmid pAM404 with the isoprene synthase coding sequence of plasmid Genetrix2082. DNA fragment IS2082 was generated by PCR amplifying plasmid Genetrix2082 using primers YD-198-70E (SEQ ID NO: 89) and YD-198-70F (SEQ ID NO: 90), digesting the PCR product to completion using restriction endonucleases *BamHI* and *NheI*, resolving the reaction mixture by gel electrophoresis, and gel purifying the approximately 1.8 kb DNA fragment comprising the isoprene synthase coding sequence. Expression plasmid pAM404 was digested to completion using restriction endonucleases *BamHI* and *NheI*, the reaction mixture was resolved by gel electrophoresis, the approximately 7.3 kb vector backbone (lacking the  $\beta$ -farnesene synthase coding sequence) was gel purified, and the purified vector backbone was ligated with DNA fragment IS2082, yielding pAM1551.

**[00156]** Expression plasmid pAM1552 was generated by replacing the  $\beta$ -farnesene synthase coding sequence of expression plasmid pAM404 with a truncated version of the isoprene synthase coding sequence of plasmid Genetrix2082. DNA fragment IS2082T was generated by PCR amplifying plasmid Genetrix2082 using primers YD-198-70F (SEQ ID NO: 90) and YD-198-70I (SEQ ID NO: 93), digesting the PCR product to completion using restriction endonucleases *Bam*HI and *Nhe*I, resolving the reaction mixture by gel electrophoresis, and gel purifying the approximately 1.64 kb DNA fragment comprising the truncated isoprene synthase coding sequence. Expression plasmid pAM404 was digested to completion using restriction endonucleases *Bam*HI and *Nhe*I, the reaction mixture was resolved by gel electrophoresis, the approximately 7.3 kb vector backbone (lacking the  $\beta$ -farnesene synthase coding sequence) was gel purified, and the purified vector backbone was ligated with DNA fragment IS2082T, yielding pAM1552.

**[00157]** Plasmid pAM840 was generated by inserting the coding sequence of the *hisG* gene into the pCR®2.1-TOPO vector (Invitrogen, Carlsbad, CA). The coding sequence of the *hisG* gene was PCR amplified using primers KB34 (SEQ ID NO: 75) and KB39 (SEQ ID NO: 76) and plasmid pNKY51 (Alani et al. (1987) *Genetics* 116(4):541-555) as template. The amplified DNA fragment was ligated with the Topo vector as per manufacturer's suggested protocol, yielding pAM840.

**[00158]** Plasmid pAM728 was generated by introducing the coding sequence of the farnesene synthase gene of *Artemisia annua* (GenBank accession number AY835398) codon-optimized for expression in *Saccharomyces cerevisiae* and under control of the promoter of the *GAL7* gene of *Saccharomyces cerevisiae* ( $P_{GAL7}$ ) into plasmid pRS425 (Christianson et al. (1992) *Gene* 110(1):119-122). An approximately 0.5 kb DNA fragment comprising  $P_{GAL7}$  was PCR amplified from Y002 genomic DNA using primers GW-110-26-pGAL7-PstI F (SEQ ID NO: 119) and GW-110-26-pGAL7 R (SEQ ID NO: 120) and was gel purified. An approximately 2 kb DNA fragment comprising the coding sequence of the farnesene synthase gene was PCR amplified using primers GW-110-26-pGAL7-FS F (SEQ ID NO: 121) and GW-110-26-FS-BamHI R (SEQ ID NO: 122). The two DNA fragments were stitched together using PCR primers GW-110-26-pGAL7-PstI F (SEQ ID NO: 119) and GW-110-26-FS-BamHI R (SEQ ID NO: 122) to create a  $P_{GAL7}$ -FS-tCYC1 insert. The  $P_{GAL7}$ -FS-tCYC1 insert and plasmid pRS425 were digested to completion using *Pst*I and *Bam*HI restriction endonucleases, and the two DNA fragments were ligated, yielding pAM728.

[00159] Plasmid pAM940 was generated by introducing the farnesene synthase sequence of plasmid pAM728 into plasmid pRS426 (Christianson et al. (1992) Gene 110(1):119-122). Plasmids pAM728 and pRS426 were digested to completion using *XhoI* and *BamHI* restriction endonucleases, the reaction mixtures were resolved by gel electrophoresis, the approximately 5.7 kb pRS426 vector backbone and the approximately 2.5 kb P<sub>GAL7</sub>-FS-tCYC1 insert of pAM728 were gel purified, and the two DNA fragments were ligated, yielding plasmid pAM940.

[00160] Plasmid pAM489 was generated by inserting the ERG20-P<sub>GAL</sub>-tHMGR insert of vector pAM471 into vector pAM466. Vector pAM471 was generated by inserting DNA fragment ERG20-P<sub>GAL</sub>-tHMGR, which comprises the open reading frame (ORF) of the ERG20 gene of *Saccharomyces cerevisiae* (ERG20 nucleotide positions 1 to 1208; A of ATG start codon is nucleotide 1) (ERG20), the genomic locus containing the divergent GAL1 and GAL10 promoter of *Saccharomyces cerevisiae* (GAL1 nucleotide position -1 to -668) (P<sub>GAL</sub>), and a truncated ORF of the HMG1 gene of *Saccharomyces cerevisiae* (HMG1 nucleotide positions 1586 to 3323) (tHMGR), into the TOPO Zero Blunt II cloning vector (Invitrogen, Carlsbad, CA). Vector pAM466 was generated by inserting DNA fragment TRP1<sup>-856 to +548</sup>, which comprises a segment of the wild-type TRP1 locus of *Saccharomyces cerevisiae* that extends from nucleotide position -856 to position 548 and harbors a non-native internal *XmaI* restriction site between bases -226 and -225, into the TOPO TA pCR2.1 cloning vector (Invitrogen, Carlsbad, CA). DNA fragments ERG20-P<sub>GAL</sub>-tHMGR and TRP1<sup>-856 to +548</sup> were generated by PCR amplification as outlined in Table 1. For the construction of pAM489, 400 ng of pAM471 and 100 ng of pAM466 were digested to completion using *XmaI* restriction enzyme (New England Biolabs, Ipswich, MA), DNA fragments corresponding to the ERG20-P<sub>GAL</sub>-tHMGR insert and the linearized pAM466 vector were gel purified, and 4 molar equivalents of the purified insert was ligated with 1 molar equivalent of the purified linearized vector, yielding pAM489. Figure 7A shows a map of the ERG20-P<sub>GAL</sub>-tHMGR insert, and SEQ ID NO: 9 shows the nucleotide sequence of the DNA fragment and the flanking TRP1 sequences.

PCR Round	Template	Primer 1	Primer 2	PCR Product
1	100 ng of Y051 genomic DNA	61-67-CPK001-G (SEQ ID NO: 23)	61-67-CPK002-G (SEQ ID NO: 24)	TRP1 <sup>-856 to -226</sup>
		61-67-CPK003-G (SEQ ID NO: 25)	61-67-CPK004-G (SEQ ID NO: 26)	TRP1 <sup>-225-to +548</sup>
	100 ng of EG123 genomic DNA	61-67-CPK025-G (SEQ ID NO: 47)	61-67-CPK050-G (SEQ ID NO: 55)	ERG20
	100 ng of Y002 genomic DNA	61-67-CPK051-G (SEQ ID NO: 56)	61-67-CPK052-G (SEQ ID NO: 57)	P <sub>GAL</sub>
		61-67-CPK053-G (SEQ ID NO: 58)	61-67-CPK031-G (SEQ ID NO: 48)	tHMGR
2	100 ng each of TRP1 <sup>-856 to -226</sup> and TRP1 <sup>-225-to +548</sup> purified PCR products	61-67-CPK001-G (SEQ ID NO: 23)	61-67-CPK004-G (SEQ ID NO: 26)	TRP1 <sup>-856 to +548</sup>
	100 ng each of ERG20 and P <sub>GAL</sub> purified PCR products	61-67-CPK025-G (SEQ ID NO: 47)	61-67-CPK052-G (SEQ ID NO: 57)	ERG20-P <sub>GAL</sub>
3	100 ng each of ERG20-P <sub>GAL</sub> and tHMGR purified PCR products	61-67-CPK025-G (SEQ ID NO: 47)	61-67-CPK031-G (SEQ ID NO: 48)	ERG20-P <sub>GAL</sub> -tHMGR

**[00161]** Plasmid pAM491 was generated by inserting the ERG13-P<sub>GAL</sub>-tHMGR insert of vector pAM472 into vector pAM467. Vector pAM472 was generated by inserting DNA fragment ERG13-P<sub>GAL</sub>-tHMGR, which comprises the ORF of the ERG13 gene of *Saccharomyces cerevisiae* (ERG13 nucleotide positions 1 to 1626) (ERG13), the genomic locus containing the divergent GAL1 and GAL10 promoter of *Saccharomyces cerevisiae* (GAL1 nucleotide position -1 to -668) (P<sub>GAL</sub>), and a truncated ORF of the HMG1 gene of *Saccharomyces cerevisiae* (HMG1 nucleotide position 1586 to 3323) (tHMGR), into the TOPO Zero Blunt II cloning vector. Vector pAM467 was generated by inserting DNA fragment URA3<sup>-723 to 701</sup>, which comprises a segment of the wild-type URA3 locus of *Saccharomyces cerevisiae* that extends from nucleotide position -723 to position -224 and harbors a non-native internal *Xma*I restriction site between bases -224 and -223, into the TOPO TA pCR2.1 cloning vector. DNA fragments ERG13-P<sub>GAL</sub>-tHMGR and URA3<sup>-723 to 701</sup> were generated by PCR amplification as outlined in Table 2. For the construction of pAM491, 400 ng of pAM472 and 100 ng of pAM467 were digested to completion using *Xma*I restriction enzyme, DNA fragments corresponding to the ERG13-P<sub>GAL</sub>-tHMGR insert and the linearized pAM467 vector were gel purified, and 4 molar equivalents of the purified insert was ligated with 1 molar equivalent of the purified linearized vector, yielding pAM491. Figure 7B shows a map of the ERG13-P<sub>GAL</sub>-tHMGR insert, and SEQ ID NO: 10 shows the nucleotide sequence of the DNA fragment and the flanking URA3 sequences.

PCR Round	Template	Primer 1	Primer 2	PCR Product
1	100 ng of Y007 genomic DNA	61-67-CPK005-G (SEQ ID NO: 27)	61-67-CPK006-G (SEQ ID NO: 28)	URA3 <sup>-723 to -224</sup>
		61-67-CPK007-G (SEQ ID NO: 29)	61-67-CPK008-G (SEQ ID NO: 30)	URA3 <sup>-223 to 701</sup>
	100 ng of Y002 genomic DNA	61-67-CPK032-G (SEQ ID NO: 49)	61-67-CPK054-G (SEQ ID NO: 59)	ERG13
		61-67-CPK052-G (SEQ ID NO: 57)	61-67-CPK055-G (SEQ ID NO: 60)	P <sub>GAL</sub>
		61-67-CPK031-G (SEQ ID NO: 48)	61-67-CPK053-G (SEQ ID NO: 58)	tHMGR
2	100 ng each of URA3 <sup>-723 to -224</sup> and URA3 <sup>-223 to 701</sup> purified PCR products	61-67-CPK005-G (SEQ ID NO: 27)	61-67-CPK008-G (SEQ ID NO: 30)	URA3 <sup>-723 to 701</sup>
	100 ng each of ERG13 and P <sub>GAL</sub> purified PCR products	61-67-CPK032-G (SEQ ID NO: 49)	61-67-CPK052-G (SEQ ID NO: 57)	ERG13-P <sub>GAL</sub>
3	100 ng each of ERG13-P <sub>GAL</sub> and tHMGR purified PCR products	61-67-CPK031-G (SEQ ID NO: 48)	61-67-CPK032-G (SEQ ID NO: 49)	ERG13-P <sub>GAL</sub> -tHMGR

**[00162]** Plasmid pAM493 was generated by inserting the IDI1-P<sub>GAL</sub>-tHMGR insert of vector pAM473 into vector pAM468. Vector pAM473 was generated by inserting DNA fragment IDI1-P<sub>GAL</sub>-tHMGR, which comprises the ORF of the IDI1 gene of *Saccharomyces cerevisiae* (IDI1 nucleotide position 1 to 1017) (IDI1), the genomic locus containing the divergent GAL1 and GAL10 promoter of *Saccharomyces cerevisiae* (GAL1 nucleotide position -1 to -668) (P<sub>GAL</sub>), and a truncated ORF of the HMG1 gene of *Saccharomyces cerevisiae* (HMG1 nucleotide positions 1586 to 3323) (tHMGR), into the TOPO Zero Blunt II cloning vector. Vector pAM468 was generated by inserting DNA fragment ADE1<sup>-825 to 653</sup>, which comprises a segment of the wild-type ADE1 locus of *Saccharomyces cerevisiae* that extends from nucleotide position -225 to position 653 and harbors a non-native internal *Xma*I restriction site between bases -226 and -225, into the TOPO TA pCR2.1 cloning vector. DNA fragments IDI1-P<sub>GAL</sub>-tHMGR and ADE1<sup>-825 to 653</sup> were generated by PCR amplification as outlined in Table 3. For the construction of pAM493, 400 ng of pAM473 and 100 ng of pAM468 were digested to completion using *Xma*I restriction enzyme, DNA fragments corresponding to the IDI1-P<sub>GAL</sub>-tHMGR insert and the linearized pAM468 vector were gel purified, and 4 molar equivalents of the purified insert was ligated with 1 molar equivalent of the purified linearized vector, yielding vector pAM493. Figure 7C shows a map of the IDI1-P<sub>GAL</sub>-tHMGR insert, and SEQ ID NO: 11 shows the nucleotide sequence of the DNA fragment and the flanking ADE1 sequences.

PCR Round	Template	Primer 1	Primer 2	PCR Product
1	100 ng of Y007 genomic DNA	61-67-CPK009-G (SEQ ID NO: 31)	61-67-CPK010-G (SEQ ID NO: 32)	ADE1 <sup>-825 to -226</sup>
		61-67-CPK011-G (SEQ ID NO: 33)	61-67-CPK012-G (SEQ ID NO: 34)	ADE1 <sup>-225 to 653</sup>
	100 ng of Y002 genomic DNA	61-67-CPK047-G (SEQ ID NO: 54)	61-67-CPK064-G (SEQ ID NO: 69)	IDI1
		61-67-CPK052-G (SEQ ID NO: 57)	61-67-CPK065-G (SEQ ID NO: 70)	P <sub>GAL</sub>
		61-67-CPK031-G (SEQ ID NO: 48)	61-67-CPK053-G (SEQ ID NO: 58)	tHMGR
2	100 ng each of ADE1 <sup>-825 to -226</sup> and ADE1 <sup>-225 to 653</sup> purified PCR products	61-67-CPK009-G (SEQ ID NO: 31)	61-67-CPK012-G (SEQ ID NO: 34)	ADE1 <sup>-825 to 653</sup>
	100 ng each of IDI1 and P <sub>GAL</sub> purified PCR products	61-67-CPK047-G (SEQ ID NO: 54)	61-67-CPK052-G (SEQ ID NO: 57)	IDI1-P <sub>GAL</sub>
3	100 ng each of IDI1-P <sub>GAL</sub> and tHMGR purified PCR products	61-67-CPK031-G (SEQ ID NO: 48)	61-67-CPK047-G (SEQ ID NO: 54)	IDI1-P <sub>GAL</sub> - tHMGR

**[00163]** Plasmid pAM495 was generated by inserting the ERG10-P<sub>GAL</sub>-ERG12 insert of pAM474 into vector pAM469. Vector pAM474 was generated by inserting DNA fragment ERG10-P<sub>GAL</sub>-ERG12, which comprises the ORF of the ERG10 gene of *Saccharomyces cerevisiae* (ERG10 nucleotide position 1 to 1347) (ERG10), the genomic locus containing the divergent GAL1 and GAL10 promoter of *Saccharomyces cerevisiae* (GAL1 nucleotide position -1 to -668) (P<sub>GAL</sub>), and the ORF of the ERG12 gene of *Saccharomyces cerevisiae* (ERG12 nucleotide position 1 to 1482) (ERG12), into the TOPO Zero Blunt II cloning vector. Vector pAM469 was generated by inserting DNA fragment HIS3<sup>-32 to -1000</sup>-HISMX- HIS3<sup>504 to -1103</sup>, which comprises two segments of the HIS locus of *Saccharomyces cerevisiae* that extend from nucleotide position -32 to position -1000 and from nucleotide position 504 to position 1103, a HISMX marker, and a non-native *Xma*I restriction site between the HIS3<sup>504 to -1103</sup> sequence and the HISMX marker, into the TOPO TA pCR2.1 cloning vector. DNA fragments ERG10-P<sub>GAL</sub>-ERG12 and HIS3<sup>-32 to -1000</sup>-HISMX- HIS3<sup>504 to -1103</sup> were generated by PCR amplification as outlined in Table 4. For construction of pAM495, 400 ng of pAM474 and 100 ng of pAM469 were digested to completion using *Xma*I restriction enzyme, DNA fragments corresponding to the ERG10-P<sub>GAL</sub>-ERG12 insert and the linearized pAM469 vector were gel purified, and 4 molar equivalents of the purified insert was ligated with 1 molar equivalent of the purified linearized vector, yielding vector pAM495. Figure 7D shows a map of the ERG10-P<sub>GAL</sub>-ERG12 insert, and SEQ ID NO: 12 shows the nucleotide sequence of the DNA fragment and the flanking HIS3 sequences.

PCR Round	Template	Primer 1	Primer 2	PCR Product
1	100 ng of Y007 genomic DNA	61-67-CPK013-G (SEQ ID NO: 35)	61-67-CPK014alt-G (SEQ ID NO: 36)	HIS3 <sup>-32 to -1000</sup>
		61-67-CPK017-G (SEQ ID NO: 39)	61-67-CPK018-G (SEQ ID NO: 40)	HIS3 <sup>504 to -1103</sup>
		61-67-CPK035-G (SEQ ID NO: 50)	61-67-CPK056-G (SEQ ID NO: 61)	ERG10
		61-67-CPK057-G (SEQ ID NO: 62)	61-67-CPK058-G (SEQ ID NO: 63)	P <sub>GAL</sub>
		61-67-CPK040-G (SEQ ID NO: 51)	61-67-CPK059-G (SEQ ID NO: 64)	ERG12
	10 ng of plasmid pAM330 DNA **	61-67-CPK015alt-G (SEQ ID NO: 37)	61-67-CPK016-G (SEQ ID NO: 38)	HISMX
2	100 ng each of HIS3 <sup>504 to -1103</sup> and HISMX PCR purified products	61-67-CPK015alt-G (SEQ ID NO: 37)	61-67-CPK018-G (SEQ ID NO: 40)	HISMX- HIS3 <sup>504 to -1103</sup>
	100 ng each of ERG10 and P <sub>GAL</sub> purified PCR products	61-67-CPK035-G (SEQ ID NO: 50)	61-67-CPK058-G (SEQ ID NO: 63)	ERG10-P <sub>GAL</sub>
3	100ng each of HIS3 <sup>-32 to -1000</sup> and HISMX- HIS3 <sup>504 to -1103</sup> purified PCR products	61-67-CPK013-G (SEQ ID NO: 35)	61-67-CPK018-G (SEQ ID NO: 40)	HIS3 <sup>-32 to -1000</sup> -HISMX- HIS3 <sup>504 to -1103</sup>
	100 ng each of ERG10-P <sub>GAL</sub> and ERG12 purified PCR products	61-67-CPK035-G (SEQ ID NO: 50)	61-67-CPK040-G (SEQ ID NO: 51)	ERG10-P <sub>GAL</sub> -ERG12

\*\* The HISMX marker in pAM330 originated from pFA6a-HISMX6-PGAL1 as described by van Dijken et al. ((2000) Enzyme Microb. Technol. 26(9-10):706-714).

[00164] Plasmid pAM497 was generated by inserting the ERG8-P<sub>GAL</sub>-ERG19 insert of pAM475 into vector pAM470. Vector pAM475 was generated by inserting DNA fragment ERG8-P<sub>GAL</sub>-ERG19, which comprises the ORF of the ERG8 gene of *Saccharomyces cerevisiae* (ERG8 nucleotide position 1 to 1512) (ERG8), the genomic locus containing the divergent GAL1 and GAL10 promoter of *Saccharomyces cerevisiae* (GAL1 nucleotide position -1 to -668) (P<sub>GAL</sub>), and the ORF of the ERG19 gene of *Saccharomyces cerevisiae* (ERG19 nucleotide position 1 to 1341) (ERG19), into the TOPO Zero Blunt II cloning vector. Vector pAM470 was generated by inserting DNA fragment LEU2<sup>-100 to 450</sup>-HISMX- LEU2<sup>1096 to 1770</sup>, which comprises two segments of the LEU2 locus of *Saccharomyces cerevisiae* that extend from nucleotide position -100 to position 450 and from nucleotide position 1096 to position 1770, a HISMX marker, and a non-native *Xma*I restriction site between the LEU2<sup>1096 to 1770</sup> sequence and the HISMX marker, into the TOPO TA pCR2.1 cloning vector. DNA fragments ERG8-P<sub>GAL</sub>-ERG19 and LEU2<sup>-100 to 450</sup>-HISMX- LEU2<sup>1096 to 1770</sup> were generated by PCR amplification as outlined in Table 5. For the construction of pAM497, 400 ng of pAM475 and 100 ng of

pAM470 were digested to completion using *Xma*I restriction enzyme, DNA fragments corresponding to the ERG8-P<sub>GAL</sub>-ERG19 insert and the linearized pAM470 vector were purified, and 4 molar equivalents of the purified insert was ligated with 1 molar equivalent of the purified linearized vector, yielding vector pAM497. Figure 7E for a map of the ERG8-P<sub>GAL</sub>-ERG19 insert, and SEQ ID NO: 13 shows the nucleotide sequence of the DNA fragment and the flanking LEU2 sequences.

Table 5 – PCR reactions performed to generate pAM497				
PCR Round	Template	Primer 1	Primer 2	PCR Product
1	100 ng of Y007 genomic DNA	61-67-CPK019-G (SEQ ID NO: 41)	61-67-CPK020-G (SEQ ID NO: 42)	LEU2 <sup>-100 to 450</sup>
		61-67-CPK023-G (SEQ ID NO: 45)	61-67-CPK024-G (SEQ ID NO: 46)	LEU2 <sup>1096 to 1770</sup>
	10ng of plasmid pAM330 DNA **	61-67-CPK021-G (SEQ ID NO: 43)	61-67-CPK022-G (SEQ ID NO: 44)	HISMX
	100 ng of Y002 genomic DNA	61-67-CPK041-G (SEQ ID NO: 52)	61-67-CPK060-G (SEQ ID NO: 65)	ERG8
		61-67-CPK061-G (SEQ ID NO: 66)	61-67-CPK062-G (SEQ ID NO: 67)	P <sub>GAL</sub>
		61-67-CPK046-G (SEQ ID NO: 53)	61-67-CPK063-G (SEQ ID NO: 68)	ERG19
2	100 ng each of LEU2 <sup>1096 to 1770</sup> and HISMX purified PCR products	61-67-CPK021-G (SEQ ID NO: 43)	61-67-CPK024-G (SEQ ID NO: 46)	HISMX-LEU2 <sup>1096 to 1770</sup>
	100 ng each of ERG8 and P <sub>GAL</sub> purified PCR products	61-67-CPK041-G (SEQ ID NO: 52)	61-67-CPK062-G (SEQ ID NO: 67)	ERG8-P <sub>GAL</sub>
3	100 ng of LEU2 <sup>-100 to 450</sup> and HISMX-LEU2 <sup>1096 to 1770</sup> purified PCR products	61-67-CPK019-G (SEQ ID NO: 41)	61-67-CPK024-G (SEQ ID NO: 46)	LEU2 <sup>-100 to 450</sup> -HISMX-LEU2 <sup>1096 to 1770</sup>
	100 ng each of ERG8-P <sub>GAL</sub> and ERG19 purified PCR products	61-67-CPK041-G (SEQ ID NO: 52)	61-67-CPK046-G (SEQ ID NO: 53)	ERG8-P <sub>GAL</sub> -ERG19
** The HISMX marker in pAM330 originated from pFA6a-HISMX6-PGAL1 as described by van Dijken et al. ((2000) Enzyme Microb. Technol. 26(9-10):706-714).				

[00165] Plasmid pAM584 was generated by inserting DNA fragment GAL7<sup>4 to 1021</sup>-HPH-GAL1<sup>1637 to 2587</sup> into the TOPO ZERO Blunt II cloning vector (Invitrogen, Carlsbad, CA). DNA fragment GAL7<sup>4 to 1021</sup>-HPH-GAL1<sup>1637 to 2587</sup> comprises a segment of the ORF of the GAL7 gene of *Saccharomyces cerevisiae* (GAL7 nucleotide positions 4 to 1021) (GAL7<sup>4 to 1021</sup>), the hygromycin resistance cassette (HPH), and a segment of the 3' untranslated region (UTR) of the GAL1 gene of *Saccharomyces cerevisiae* (GAL1

nucleotide positions 1637 to 2587). The DNA fragment was generated by PCR amplification as outlined in Table 6. Figure 7F shows a map and SEQ ID NO: 102 the nucleotide sequence of DNA fragment GAL7<sup>4 to 1021</sup>-HPH-GAL1<sup>1637 to 2587</sup>.

PCR Round	Template	Primer 1	Primer 2	PCR Product
1	100 ng of Y002 genomic DNA	91-014-CPK236-G (SEQ ID NO: 126)	91-014-CPK237-G (SEQ ID NO: 127)	GAL7 <sup>4 to 1021</sup>
		91-014-CPK232-G (SEQ ID NO: 124)	91-014-CPK233-G (SEQ ID NO: 125)	GAL1 <sup>1637 to 2587</sup>
	10 ng of plasmid pAM547 DNA **	91-014-CPK231-G (SEQ ID NO: 123)	91-014-CPK238-G (SEQ ID NO: 128)	HPH
2	100 ng each of GAL7 <sup>4 to 1021</sup> and HPH purified PCR products	91-014-CPK231-G (SEQ ID NO: 123)	91-014-CPK236-G (SEQ ID NO: 126)	GAL7 <sup>4 to 1021</sup> -HPH
3	100 ng of each GAL1 <sup>1637 to 2587</sup> and GAL7 <sup>4 to 1021</sup> -HPH purified PCR products	91-014-CPK233-G (SEQ ID NO: 125)	91-014-CPK236-G (SEQ ID NO: 126)	GAL7 <sup>4 to 1021</sup> -HPH-GAL1 <sup>1637 to 2587</sup>
** Plasmid pAM547 was generated synthetically, and comprises the HPH cassette, which consists of the coding sequence for the hygromycin B phosphotransferase of <i>Escherichia coli</i> flanked by the promoter and terminator of the <i>Tef1</i> gene of <i>Kluyveromyces lactis</i> .				

**[00166]** Integration cassette natA-P<sub>CTR3</sub><sup>-1 to -734</sup> was generated by PCR amplifying the *natA* marker using primers PW287-002-CPK1217 (SEQ ID NO: 104) and DE\_PW91-027-CPK262-G (SEQ ID NO: 99) and using plasmid DNA comprising the TEF1 promoter and terminator of *Kluyveromyces lactis* (GenBank accession CR382122 REGIONS:788874..789380 and 787141..787496, respectively) and the nat resistance marker. In addition, the promoter of the CTR3 gene of *Saccharomyces cerevisiae* was PCR amplified from Y002 genomic DNA from positions -1 to -734 using primers PW287-002-CPK1232 (SEQ ID NO: 100) and DE\_PW91-027-CPK263-G (SEQ ID NO: 101). The 2 PCR products were stitched together in a secondary PCR reaction using 25 ng of each of the gel purified PCR fragments and primers PW287-002-CPK1217 and PW287-002-CPK1232, yielding integration cassette natA-P<sub>CTR3</sub><sup>-1 to -734</sup>.

**[00167]** Additional recombinant integration cassettes were generated by stitching RABits. RABits were generated by inserting DNA fragments of interest (MULEs) into the pMULE Entry vector.

**[00168]** The pMULE Entry vector was PCR amplified using primers K162 (SEQ ID NO: 73) and K163 (SEQ ID NO: 74) and pRYSE Entry vector 8 (SEQ ID NO: 14) as template. The reaction mixture was resolved by gel electrophoresis, and the approximately

2.2 kb vector backbone was gel purified. A DNA fragment comprising the *lacZ* coding sequence was generated by digesting to completion pRYSE Entry vector 8 using *SchI* restriction enzyme, heat inactivating the enzyme (20 min at 65°C), resolving the reaction mixture by gel electrophoresis, and gel purifying the approximately 0.5 kb DNA fragment. The purified DNA fragment comprising the *lacZ* coding sequence was ligated with the purified vector backbone, yielding the pMULE Entry vector (see Figure 8 for a plasmid map).

[00169] MULEs were PCR amplified using templates and primers as outlined in Table 7. PCR amplifications were done using the Phusion DNA polymerase (New England Biolabs, Ipswich, MA) as per manufacturer's suggested protocol.

Table 7 – Amplified MULEs			
MULE	Primers	Template	Size (bp)
5' ERG20-pGAL1/10	YD-198-75A (SEQ ID NO: 94) YD-198-75B (SEQ ID NO: 95)	pAM489	1,012
mIS2081	YD-198-75F (SEQ ID NO: 96) YD-198-75H (SEQ ID NO: 98)	Genetrix2081	1,836
mIS2081T	YD-198-75G (SEQ ID NO: 97) YD-198-75H (SEQ ID NO: 98)	Genetrix2081	1,668
tTDH3	RYSE 4 (SEQ ID NO: 77) RYSE 7 (SEQ ID NO: 78)	RABit63 *	311
Hyg	YD-198-75L (SEQ ID NO: 105) YD-198-75M (SEQ ID NO: 106)	RABit21 *	1,962
TRP1	YD-198-75N (SEQ ID NO: 107) YD-198-75O (SEQ ID NO: 108)	pAM489	586

\* RABit21 comprises SEQ ID NO: 15, and RABit63 comprises SEQ ID NO: 16.

[00170] RABits were generated by inserting the MULEs into the pMULE Entry vector. The PCR reactions were resolved by gel electrophoresis, the MULEs were gel purified, the purified MULEs were treated with T4 polynucleotide kinase (PNK) (New England Biolabs, Ipswich, MA) as per manufacturer's suggested protocol, and the PNK was heat inactivated at 65°C for 20 minutes. The pMULE Entry vector was digested to completion using *SchI* restriction enzyme, the approximately 2.2 kb pMULE Entry vector backbones (lacking *lacZ*) was gel purified, the purified pMULE Entry vector backbone was treated with Antarctic Phosphatase (New England Biolabs, Ipswich, MA), and the phosphatase was heat inactivated at 65°C for 20 minutes. The pMULE Entry vector backbone was ligated with each of the amplified MULEs, yielding RABits.

[00171] RABits to be stitched (Table 8) were placed together in one tube (333 fmole of each RABit) and digested to completion using *LguI* restriction enzyme (Fermentas, Glen Burnie, MD). The restriction enzyme was heat inactivated for 20

minutes at 65°C. The RABit digestion reactions were split into three 30 uL reactions; water, buffer, dNTPs, and DNA polymerase were added to each reaction mixture, and a first round of PCR amplification was initiated. Samples were placed on ice, 0.5 uM of each terminal primer (Table 8) were added to the reaction mixtures, and a second round of PCR amplification was performed. The three PCR reaction mixtures were combined in one tube, the reaction mixtures were resolved by gel electrophoresis, and the PCR products were gel purified. Figure 7G shows a map of the integration cassettes.

Integration Cassette	RABits to be combined	Terminal Primers for 2 <sup>nd</sup> Round PCR amplification
i00280	5' ERG20-pGAL1/10 - mIS2081 - tTDH3 – Hyg - TRP1	YD-198-75A (SEQ ID NO: 94)
i00281	5' ERG20-pGAL1/10 - mIS2081T - tTDH3 – Hyg - TRP1	YD-198-75O (SEQ ID NO: 108)

The first round of PCR amplification was performed as follows: one cycle of denature at 98°C for 2 minutes; 5 cycles of denature at 98°C for 30 seconds and anneal/extend at 72°C for 30 seconds per kilobase PCR product. The second round of PCR amplification was performed as follows: one cycle of denature at 98°C for 2 minutes; 35 rounds of denature at 98°C for 12 seconds and anneal/extend at 72°C for 20 seconds per kilobase PCR product; one cycle of final extend at 72°C for 7 minutes; and a final hold at 4°C.

### Example 3

**[00172]** This example describes methods for generating *Saccharomyces cerevisiae* strains expressing heterologous isoprene synthases.

**[00173]** *Saccharomyces cerevisiae* strains CEN.PK2-1C (Y002) (MATA; ura3-52; trp1-289; leu2-3,112; his3Δ1; MAL2-8C; SUC2) and CEN.PK2-1D (Y003) (MATalpha; ura3-52; trp1-289; leu2-3,112; his3Δ1; MAL2-8C; SUC2) (van Dijken et al. (2000) Enzyme Microb. Technol. 26(9-10):706-714) were prepared for introduction of inducible MEV pathway genes by replacing the *ERG9* promoter with the *Saccharomyces cerevisiae* *MET3* promoter, and the *ADE1* ORF with the *Candida glabrata* *LEU2* gene (*CgLEU2*). This was done by PCR amplifying the KanMX-P<sub>MET3</sub> region of vector pAM328 (SEQ ID NO: 17) using primers 50-56-pw100-G (SEQ ID NO: 19) and 50-56-pw101-G (SEQ ID NO: 20), which include 45 base pairs of homology to the native *ERG9* promoter, transforming 10 μg of the resulting PCR product into exponentially growing Y002 and Y003 cells using 40% w/w Polyethelene Glycol 3350 (Sigma-Aldrich, St. Louis, MO), 100 mM Lithium Acetate (Sigma-Aldrich, St. Louis, MO), and 10 μg Salmon Sperm DNA (Invitrogen Corp., Carlsbad, CA), and incubating the cells at 30°C for 30 minutes followed by heat shocking them at 42°C for 30 minutes (Schiestl and Gietz. (1989) *Curr. Genet.* 16, 339-346). Positive recombinants were identified by their ability to grow on rich medium containing 0.5 μg/ml Geneticin (Invitrogen Corp., Carlsbad, CA), and selected colonies

were confirmed by diagnostic PCR. The resultant clones were given the designation Y93 (MAT A) and Y94 (MAT alpha). The 3.5 kb *CgLEU2* genomic locus was then amplified from *Candida glabrata* genomic DNA (ATCC, Manassas, VA) using primers 61-67-CPK066-G (SEQ ID NO: 71) and 61-67-CPK067-G (SEQ ID NO: 72), which contain 50 base pairs of flanking homology to the *ADE1* ORF, and 10 µg of the resulting PCR product were transformed into exponentially growing Y93 and Y94 cells, positive recombinants were selected for growth in the absence of leucine supplementation, and selected clones were confirmed by diagnostic PCR. The resultant clones were given the designation Y176 (MAT A) and Y177 (MAT alpha).

[00174] Strain Y188 was generated by digesting 2 µg of pAM491 and pAM495 plasmid DNA to completion using *PmeI* restriction endonuclease (New England Biolabs, Beverly, MA), and introducing the purified DNA inserts into exponentially growing Y176 cells. Positive recombinants were selected for by growth on medium lacking uracil and histidine, and integration into the correct genomic locus was confirmed by diagnostic PCR.

[00175] Strain Y189 was generated by digesting 2 µg of pAM489 and pAM497 plasmid DNA to completion using *PmeI* restriction endonuclease, and introducing the purified DNA inserts into exponentially growing Y177 cells. Positive recombinants were selected for by growth on medium lacking tryptophan and histidine, and integration into the correct genomic locus was confirmed by diagnostic PCR.

[00176] Strain Y238 was generated by mixing approximately  $1 \times 10^7$  cells from strains Y188 and Y189 on a YPD medium plate for 6 hours at room temperature to allow for mating, plating the mixed cell culture to medium lacking histidine, uracil, and tryptophan to select for growth of diploid cells, digesting 2 µg of pAM493 plasmid DNA to completion using *PmeI* restriction endonuclease, and introducing the purified DNA insert into the exponentially growing diploid cells. Positive recombinants were selected for by growth on medium lacking adenine, and integration into the correct genomic locus was confirmed by diagnostic PCR.

[00177] Strains Y210 (Mat A) and Y211 (MAT alpha) were generated by sporulating strain Y238 in 2% Potassium Acetate and 0.02% Raffinose liquid medium, isolating approximately 200 genetic tetrads using a Singer Instruments MSM300 series micromanipulator (Singer Instrument LTD, Somerset, UK), identifying independent genetic isolates containing the appropriate complement of introduced genetic material by

their ability to grow in the absence of adenine, histidine, uracil, and tryptophan, and confirming the integration of all introduced DNA by diagnostic PCR.

**[00178]** Strain Y258 was generated by transforming strain Y211 with pAM404 plasmid DNA. Host cell transformants were selected on synthetic defined media, containing 2% glucose and all amino acids except leucine (SM-glu). Single colonies were transferred to culture vials containing 5 mL of liquid SM-glu lacking leucine, and the cultures were incubated by shaking at 30°C until growth reached stationary phase. The cells were stored at -80°C in cryo-vials in 1 mL frozen aliquots made up of 400 uL 50% sterile glycerol and 600 uL liquid culture.

**[00179]** Strains Y225 (MAT A) and Y227 (MAT alpha) were generated by transforming exponentially growing Y210 and Y211 cells, respectively, with 2 µg of pAM426 (SEQ ID NO: 18), which comprises a GAL1 promoter operably linked to the coding sequence of an amorpho-4,11-diene synthase gene that is codon-optimized for expression in *Saccharomyces cerevisiae* (Merke et al. (2000) *Ach. Biochem. Biophys.* 381:173-180). Host cell transformants were selected on complete synthetic defined media lacking leucine.

**[00180]** Strain Y337 was generated from strain Y227 by rendering the strain unable to catabolize galactose. To this end, pAM584 plasmid DNA was digested to completion using *PmeI* restriction endonuclease, and the purified DNA insert GAL7<sup>4 to 1021</sup>-HPH-GAL1<sup>1637 to 2587</sup> was introduced into exponentially growing Y227 cells. Positive recombinants were selected for by growth on solid medium lacking adenine, leucine, lysine, histidine, methionine, uracil, and tryptophan, and containing 900 µg/mL hygromycin B (Sigma, St. Louis, MO). Integration into the correct genomic locus was confirmed by diagnostic PCR and by testing the strain for inability to use galactose as a carbon source.

**[00181]** Strain Y615 was generated from strain Y337 by replacing the URA3 open reading frame with the hisG open reading frame from *Salmonella sp.*. A DNA fragment comprising the hisG open reading frame was PCR amplified from pAM840 using primers 100-150-KB034-G (SEQ ID NO: 109) and 100-150-KB039-G (SEQ ID NO: 110), and the purified DNA fragment was introduced into exponentially growing Y337 cells. Positive transformants were selected for their ability to grow on medium containing 5-fluoroorotic acid and for their inability to grow on medium lacking uracil. Integration into the correct genomic locus was confirmed by diagnostic PCR.

**[00182]** Strain Y1775 was generated from strain Y615 by replacing the kanMX marker with the URA3 marker. A DNA fragment encoding the *S. cerevisiae* URA3 auxotrophic marker was PCR amplified from pAM64 (SEQ ID NO: 103) using primers PW-191-046-CPK1212-G (SEQ ID NO: 111) and PW-191-046-CPK1213-G (SEQ ID NO: 112), and the purified DNA fragment was introduced into exponentially growing Y615 cells. Positive recombinants were selected for by growth on medium lacking adenine, leucine, lysine, histidine, methionine, uracil, and tryptophan. Integration into the correct genomic locus was confirmed by diagnostic PCR.

**[00183]** Strain Y1791 was generated from strain Y1775 by restoring the ERG9 locus. A DNA fragment comprising the ERG9 open reading frame was PCR amplified from Y002 genomic DNA using primers PW-191-015-CPK947-G (SEQ ID NO: 113) and PW-191-015-CPK950-G (SEQ ID NO: 114), and the purified DNA fragment was introduced into exponentially growing Y1775 cells. Positive transformants were selected for their ability to grow on medium containing 5-fluoroorotic acid and for their inability to grow on medium lacking uracil. Integration into the correct genomic locus was confirmed by diagnostic PCR.

**[00184]** Strain Y1856 was generated from strain Y1791 by restoring the GAL1, GAL10, and GAL7 locus. A DNA fragment comprising the GAL1, GAL10, and GAL7 genomic region was PCR amplified from Y002 genomic DNA using primers PW-91-093-CPK453-G (SEQ ID NO: 115) and PW-091-144-CPK689-G (SEQ ID NO: 116), and the purified DNA fragment was introduced into exponentially growing Y1791 cells. Positive recombinants were selected for by growth on medium containing 20 g/L galactose and their inability to grow on medium containing 900 µg/mL hygromycin B.

**[00185]** Strain Y1857 was generated from strain Y1856 by disrupting the P<sub>GAL10</sub>-ERG20 locus. A DNA fragment encoding the *S. cerevisiae* URA3 auxotrophic marker was PCR amplified from pAM64 (SEQ ID NO: 130) using primers PW-287-002-CPK1215-G (SEQ ID NO: 117) and PW-287-002-CPK1216-G (SEQ ID NO: 118), and the purified DNA fragment was introduced into exponentially growing Y1856 cells. Positive recombinants were selected for by growth on medium lacking adenine, leucine, lysine, histidine, methionine, uracil, and tryptophan. Integration into the correct genomic locus was confirmed by diagnostic PCR.

**[00186]** Strain Y1895 was generated from strain Y1857 by curing the strain from pAM426. Strain Y1857 was propagated in rich Yeast Extract Peptone Dextrose (YPD) medium containing 0.5% leucine (w/v) for 5 days. Every 12 hours, fresh YPD 0.5% LEU was

inoculated to an OD<sub>600</sub> of 0.05 using the previous 12 hour growth. After 5 days, the cells were plated on YPD 0.5% leucine agar medium and incubated at 30°C for 2 days. Cured cells were identified by their ability to grow on minimal medium containing leucine and their inability to grow on medium lacking leucine.

**[00187]** Strain Y736 was generated from strain Y227 by replacing the URA3 marker with a hisG marker. To this end, the hisG marker was PCR amplified using primers KB34 (SEQ ID NO: 75) and KB39 (SEQ ID NO: 76) and plasmid pAM840 as template. Exponentially growing Y211 cells were transformed with the PCR mixture and were then plated on YPD overnight. Host cell transformants were selected by replica plating cells from the YPD plates onto Complete Synthetic Medium (CSM) solid media lacking methionine and leucine and containing 0.1% 5-FOA and 0.1 mg/ml uracil.

**[00188]** Strain Y737 was generated from strain Y736 by transforming exponentially growing cells with pAM940, and selecting host cell transformants on CSM solid media lacking leucine and uracil.

**[00189]** Strain Y846 was generated from strain Y737 by curing the strain of pAM426. To this end, strain Y737 was grown for 3 successive nights in rich media supplemented with 6x the usual concentration of leucine, being diluted each morning 100x. The cells were then plated out to well-separated single colonies on rich media and replica plated onto minimal media lacking leucine. Colonies that grew on rich media but did not grow in the absence of leucine were picked, grown, and tested by PCR to verify that the plasmid was no longer present. One such positive colony was stocked as Y846.

**[00190]** Strain Y1858 was generated from strain Y1895 by heterologous expression of an isoprene synthase. To this end, exponentially growing Y1895 cells were transformed with expression plasmid pAM1547. Host cell transformants were selected on CSM agar lacking methionine and leucine and containing 2% glucose.

**[00191]** Strain Y1859 was generated from strain Y1895 by heterologous expression of an isoprene synthase. To this end, exponentially growing Y1895 cells were transformed with expression plasmid pAM1548. Host cell transformants were selected on CSM agar lacking methionine and leucine and containing 2% glucose.

**[00192]** Strain Y1860 was generated from strain Y1895 by heterologous expression of an isoprene synthase. To this end, exponentially growing Y1895 cells were transformed with expression plasmid pAM1549. Host cell transformants were selected on CSM agar lacking methionine and leucine and containing 2% glucose.

[00193] Strain Y1861 was generated from strain Y1895 by heterologous expression of an isoprene synthase. To this end, exponentially growing Y1895 cells were transformed with expression plasmid pAM1550. Host cell transformants were selected on CSM agar lacking methionine and leucine and containing 2% glucose.

[00194] Strain Y1713 was generated from strain Y846 by replacing the ERG20 gene with the coding sequence for an isoprene synthase. To this end, exponentially growing Y846 cells were transformed with integration cassette i00280. Host cell transformants were selected on YPD agar containing 2% glucose and 300 µg/mL hygromycin B (A.G. Scientific, San Diego, CA).

[00195] Strain Y1714 was generated from strain Y846 by replacing the ERG20 gene with a coding sequence for a truncated isoprene synthase. To this end, exponentially growing Y846 cells were transformed with integration cassette i00281. Host cell transformants were selected on YPD agar containing 2% glucose and 300 µg/mL hygromycin B (A.G. Scientific, San Diego, CA).

[00196] Strain Y1732 was generated from strain Y846 by heterologous expression of an isoprene synthase. To this end, exponentially growing Y846 cells were transformed with expression plasmid pAM1549. Host cell transformants were selected on CSM agar lacking methionine and leucine and containing 2% glucose.

[00197] Strain Y1733 was generated from strain Y846 by heterologous expression of a truncated isoprene synthase. To this end, exponentially growing Y846 cells were transformed with expression plasmid pAM1550. Host cell transformants were selected on CSM agar lacking methionine and leucine and containing 2% glucose.

[00198] Strain Y1837 was generated by transforming exponentially growing Y1713 cells with expression plasmid pAM1549. Host cell transformants were selected on CSM agar lacking methionine and leucine and containing 2% glucose.

[00199] Strain Y1838 was generated by transforming exponentially growing Y1714 cells with expression plasmid pAM1550. Host cell transformants were selected on CSM agar lacking methionine and leucine and containing 2% glucose.

[00200] Strain 1907 was generated from strain Y1860 by replacing the ERG20 promoter with the nourseothricin resistance marker (*natA*) and the copper repressible promoter of the *CTR3* gene of *Saccharomyces cerevisiae*. To this end, exponentially growing Y1860 cells were transformed with 200 µg of the integration cassette *natA-P<sub>CTR3</sub>*<sup>1 to -734</sup>. Host cell transformants were selected for by growth on rich YPD medium containing 300 µg/mL nourseothricin (Werner BioAgents, Jena, Germany).

Example 4

[00201] This example describes methods for producing isoprene in *Saccharomyces cerevisiae* host strains.

[00202] Single colonies of host cell transformants were transferred to culture vials containing 5 mL of Bird Seed Medium containing 0.25 uM CuSO<sub>4</sub>. The following day, 20 mL of Bird Production Medium containing 1.8% galactose, 0.2% glucose, and 32 uM CuSO<sub>4</sub>, with 4 mL isopropylmyristate, was inoculated with host cell transformant Y1858, Y1859, Y1860, or Y1861 to an OD<sub>600</sub> of 0.05. Similarly, 20 mL of Bird Production Medium containing 1.8% galactose and 0.2% glucose, with 4 mL isopropylmyristate, was inoculated with isolates #3, 6, or 9 of host cell transformant Y1907 to an OD<sub>600</sub> of 0.05. To the Y1907 culture, 0.25 uM CuSO<sub>4</sub>, 50 uM CuSO<sub>4</sub>, or 150 uM CuSO<sub>4</sub> was added. The shake flasks were sealed for anaerobic growth and incubated at 30°C on a rotary shaker at 200 rpm.

After 72 hours of growth, the cultures were assayed for cell growth. At the same time, 200 uL of isopropylmyristate was removed from each flask and were injected directly on an Agilent 7980 gas chromatograph equipped with a flame ionization detector. To expedite run times, the temperature program and column matrix were modified to achieve optimal resolution and the shortest overall runtime (15.0 min). Each 2 µL sample was split 10:1 and was separated using a Varian fused silica CP-PoraBond U PLOT (25 m x 0.32 mm x 7 um; length x width x film thickness) column with hydrogen as the carrier gas. The temperature program for the analysis was as follows: the column was initially held at 100°C for 1 minute, followed by a temperature gradient of 10°C/min to a temperature of 140°C, followed by a temperature gradient of 40°C/min to a temperature of 250°C, followed by holding the column at 250°C for 6.5 min. Under these conditions, isoprene elutes at 5.8 minutes.

**What is claimed is:**

1. A method of purifying isoprene comprising:
  - a. obtaining a first gaseous composition comprising isoprene and water, wherein the gaseous composition comprises 1 part per million or less of C<sub>2</sub>-C<sub>5</sub> alkyne;
  - b. flowing the first gaseous composition through a first chiller wherein the first chiller has a temperature of between about 10 °C and about -15 °C thereby resulting in a second gaseous composition and wherein the second gaseous composition comprises less water than the first gaseous composition;
  - c. flowing the second gaseous composition through a second chiller wherein the second chiller has a temperature below -35 °C; and
  - d. collecting the resulting liquid isoprene composition.
2. The method of claim 1, wherein the water is present in the first gaseous composition in an amount that is greater than 70% of its saturation amount.
3. The method of claim 1, wherein the first gaseous isoprene composition further comprise carbon dioxide in an amount between about 0.1% and about 35% by volume.
4. The method of claim 1, wherein the first gaseous composition further comprises 1 part per million or less of cyclopentadiene, piperylene and 1,4-pentadiene.
5. The method of claim 1, wherein the first chiller is cooled using a propylene refrigeration system.
6. The method of claim 1, wherein the first chiller is cooled using an ammonium refrigeration system.
7. The method of claim 1, wherein the gaseous composition is flowed through a drier prior to flowing through the first chiller.
8. The method of claim 1, wherein the gaseous composition is flowed through a drier after flowing through the first chiller.

9. The method of claim 1, wherein the second chiller has a temperature of about -60 °C to about -85 °C.
10. The method of claim 1, wherein the second chiller has a temperature of less than about -65 °C.
11. The method of claim 1, wherein the second chiller is cooled using an ethylene refrigeration system.
12. The method of claim 1, further comprising nitrogen stripping the liquid isoprene composition.
13. The method of claim 1, further comprising passing the first gaseous composition through a modified zeolite membrane to separate hydrocarbon impurities from the isoprene.
14. The method of claim 1, further comprising passing the second gaseous composition through a modified zeolite membrane to separate hydrocarbon impurities from the isoprene.
15. The method of claim 1, further comprising passing the liquid isoprene composition through a modified zeolite membrane to separate hydrocarbon impurities from the isoprene.
16. A method of making isoprene comprising:
  - a. culturing a plurality of host cells capable of making isoprene;
  - b. forming a first gaseous composition comprising isoprene and water, wherein the water is present in an amount greater than about 70% of its saturation amount;
  - c. subjecting the first gaseous composition to a first cooling step whereby substantially all of the water is removed from the first gaseous composition resulting a second gaseous composition; and
  - d. subjecting the second gaseous composition to a second cooling step whereby a liquid isoprene composition is collected.

17. The method of claim 16, further comprising nitrogen stripping the liquid isoprene composition.
18. The method of claim 16, wherein the isoprene is present in an amount that is about 0.1% and about 15% by volume in the first gaseous composition.
19. The method of claim 16, wherein the first gaseous composition further comprises carbon dioxide in an amount between about 1% and about 35% by volume.
20. The method of claim 16, wherein the first cooling step cools the first gaseous composition to a temperature between about 10 °C and about -15 °C.
21. The method of claim 16, wherein the first cooling step is cooled using a propylene refrigeration system.
22. The method of claim 16, wherein the first cooling step is cooled using an ammonium refrigeration system.
23. The method of claim 16, wherein the second cooling step cools the second gaseous composition to a temperature between about -60 °C and about -85 °C.
24. The method of claim 16, wherein the second cooling step is cooled using an ethylene refrigeration system.
25. The method of claim 16, wherein the host cells are selected from the genus *Bacillus*, *Escherichia* or *Acinetobacter*.
26. The method of claim 25, wherein the host cells are *Escherichia coli*.
27. The method of claim 16, wherein the host cells are yeast.
28. The method of claim 26, wherein the host cells are *Saccharomyces cerevisie*.

29. A gaseous isoprene composition comprising isoprene and water wherein the water is present in an amount that is greater than about 70% of its saturation amount and wherein the gaseous isoprene composition comprises 1 part per million or less of C<sub>2</sub>-C<sub>5</sub> alkynes.
30. The composition of claim 29, wherein the isoprene is present in an amount between about 0.1% and about 15% by volume.
31. The composition of claim 29, further comprising carbon dioxide in an amount between about 1% and about 35% by volume.
32. The gaseous isoprene composition of claim 29, wherein the isoprene is present in an amount between about 0.1% and about 15% by volume and the water is present in an amount that is greater than about 90% of its saturation amount and wherein the gaseous isoprene composition further comprises carbon dioxide in an amount between about 1% and about 35% by volume and nitrogen in an amount between about 50% and about 75% by volume.
33. A liquid isoprene composition comprising at least 65% isoprene by weight and wherein the isoprene composition comprises 1 part per million or less of C<sub>2</sub>-C<sub>5</sub> alkynes, cyclopentadiene, piperylene, and 1,4-pentadiene.
34. The composition of claim 33, wherein the composition comprises at least 95% isoprene by weight.
35. The composition of claim 33, wherein the composition comprises at least 99% isoprene by weight.
36. The composition of claim 33, wherein the composition comprises at least 99.5% isoprene by weight.
37. The composition of claim 33, wherein the liquid isoprene composition further comprises dissolved carbon dioxide that is present in an amount greater than about 0.01% by weight.

38. The composition of claim 33, wherein the liquid isoprene composition further comprises dissolved carbon dioxide that is present in an amount greater than about 0.1% by weight.
39. A method of making isoprene comprising:
- a. contacting a plurality of host cells capable of making isoprene in an aqueous medium wherein the aqueous medium is in contact with an immiscible organic liquid and the aqueous medium, the host cells, and the immiscible organic liquid is in a closed vessel; and
  - b. culturing the host cells in the aqueous medium whereby the host cells make isoprene and the isoprene is captured in the immiscible organic liquid.
40. The method of claim 39, further comprising quantiating the amount of isoprene in the immiscible organic liquid.
41. The method of claim 39, further comprising separating the immiscible organic liquid from the aqueous medium and separating the isoprene from the immiscible organic liquid.
42. The method of claim 39, wherein the isoprene is separated from the organic liquid by heating the organic liquid to a temperature above above 34 °C.
43. The method of claim 39, wherein the host cells are selected from the genus *Bacillus*, *Escherichia* or *Acinetobacter*.
44. The method of claim 43, wherein the host cells are *Escherichia coli*.
45. The method of claim 39, wherein the host cells are yeast.
46. The method of claim 45, wherein the host cells are *Saccharomyces cerevisie*.
47. An isoprene production system comprising:
- a. a closed vessel;
  - b. an aqueous medium, within the vessel, forming a first phase;

- c. a plurality of host cells, within the aqueous medium, capable of making isoprene; and
  - d. a liquid organic second phase, capable of capturing the isoprene made by the host cells, in contact with the first phase.
48. An isoprene production system comprising:
- a. a bioreactor capable of culturing a plurality of host cells;
  - b. a first chiller and flash drum operably connected to the overhead stream of the bioreactor, the first chiller capable of operating in a temperature range of between 10°C and -15°C; and
  - c. a second chiller and flash drum operably connected to the overhead stream exiting from the first chiller and flash drum, the second chiller capable of operating in a temperature below -35°C.
49. The isoprene production system of claim 48, wherein the bioreactor has a capacity of greater than 100 liters.
50. The isoprene production system of claim 48, wherein the exiting overhead stream from the second chiller and flash drum is operably connected to the cooling stream inlet of the first chiller.
51. The isoprene production system of claim 48, wherein the system further comprises a nitrogen stripper operably connected to the bottom stream exiting from the second chiller and flash drum.
52. The isoprene production system of claim 48, wherein the second chiller is capable of operating at between about -65°C and about -85°C.
53. A method of purifying isoprene comprising:
- a. obtaining a first gaseous composition comprising:
    - i) isoprene in an amount between about 0.1% and about 15% by volume;
    - ii) carbon dioxide in an amount between about 0.04% and about 35% by volume;

- iii) oxygen in an amount between about 1% and about 20% by volume;
  - iv) nitrogen in an amount greater than about 50% by volume;
  - v) argon in an amount less than about 0.9% by volume;
  - vi) water in an amount greater than about 70% of its saturation amount;
  - vii) 1 part per million or less of C<sub>2</sub>-C<sub>5</sub> alkyne, cyclopentadiene, piperylene, and 1,4-pentadiene; and
  - viii) ethanol;
- b. flowing the first gaseous composition through a first chiller and an operably connected flash drum, wherein the first chiller has a temperature of between about 10 °C and about -15 °C thereby resulting in a second gaseous composition and wherein the second gaseous composition comprises less water than the first gaseous composition;
  - c. flowing the second gaseous composition through a second chiller and an operably connected flash drum, wherein the second chiller has a temperature between about -35°C and about -85°C; and
  - d. collecting the resulting liquid isoprene composition.
54. The method of claim 53, wherein the first gaseous composition is obtained by culturing a plurality of host cells capable of making isoprene.
55. The method of claim 54, wherein the host cells are yeast.
56. The method of claim 54, wherein the host cells are *Saccharomyces cerevisie*.
57. The method of claim 53, wherein the resulting second gaseous composition comprises less than about 3% by weight of water.
58. The method of claim 53, wherein the resulting liquid isoprene composition comprises less than about 1% by weight of water.
59. The method of claim 53, wherein the resulting liquid isoprene composition comprises less than about 1% by weight of carbon dioxide.

60. The method of claim 53, wherein the resulting liquid isoprene composition comprises less than about 1% by weight of nitrogen.
61. The method of claim 53, wherein the resulting liquid isoprene composition comprises:
- i) at least 65% isoprene by weight; and
  - ii) less than 1% water by weight.
62. The method of claim 53, wherein the resulting liquid isoprene composition comprises less than about 1% by weight of ethanol.
63. The method of claim 53, further comprising nitrogen stripping the liquid isoprene composition.
64. The method of claim 63, wherein the liquid isoprene composition comprises at least 70% isoprene by weight and less than 1% by weight of dissolved carbon dioxide.
65. The method of claim 63, wherein the liquid isoprene composition comprises at least 90% isoprene by weight and less than 1% by weight of dissolved carbon dioxide.
66. The method of claim 63, wherein the liquid isoprene composition comprises at least 95% isoprene by weight and less than 1% by weight of dissolved carbon dioxide.
67. The method of claim 63, wherein the liquid isoprene composition comprises at least 99% isoprene by weight and less than 0.05% by weight of dissolved carbon dioxide.

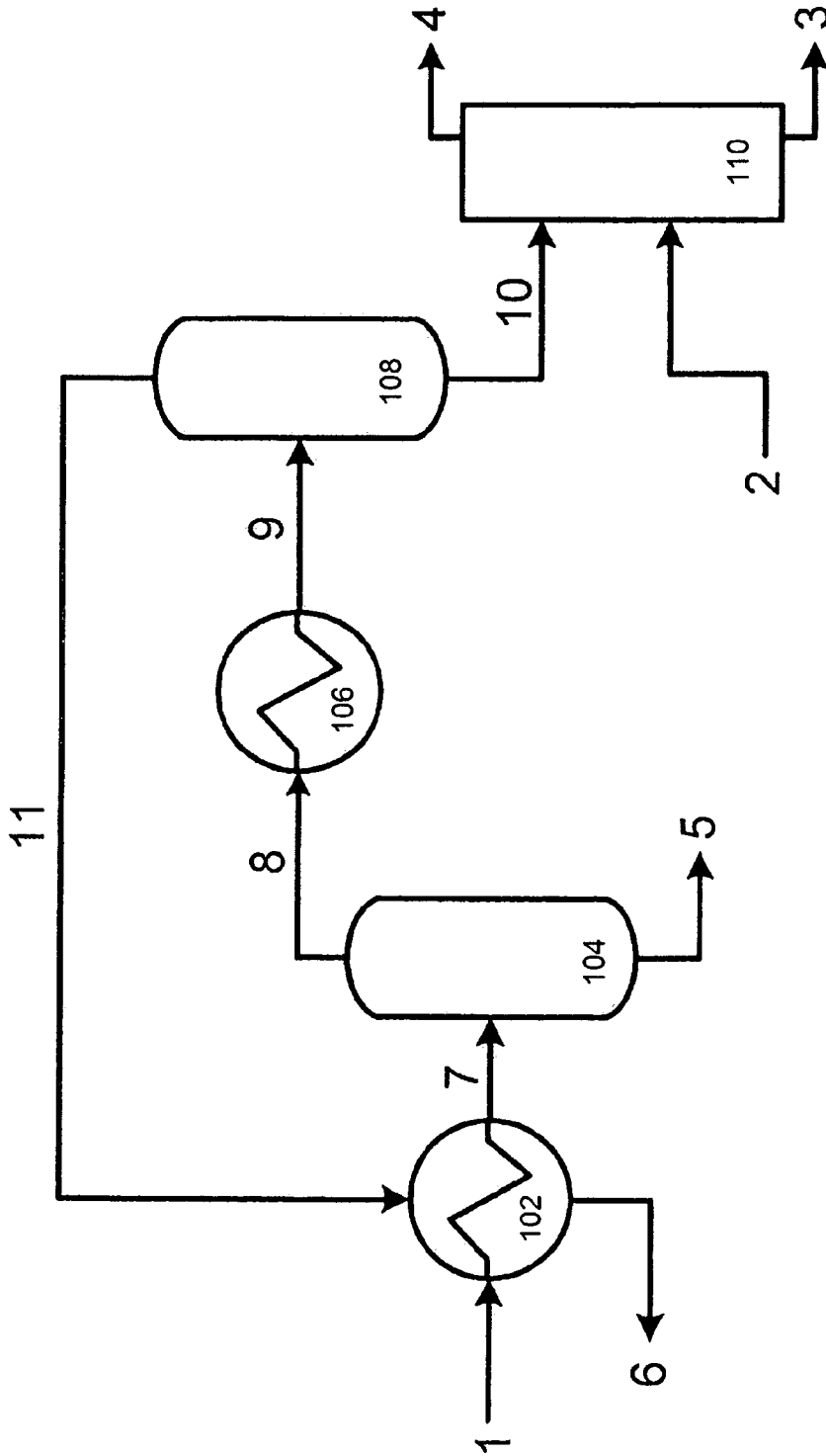

FIG. 1

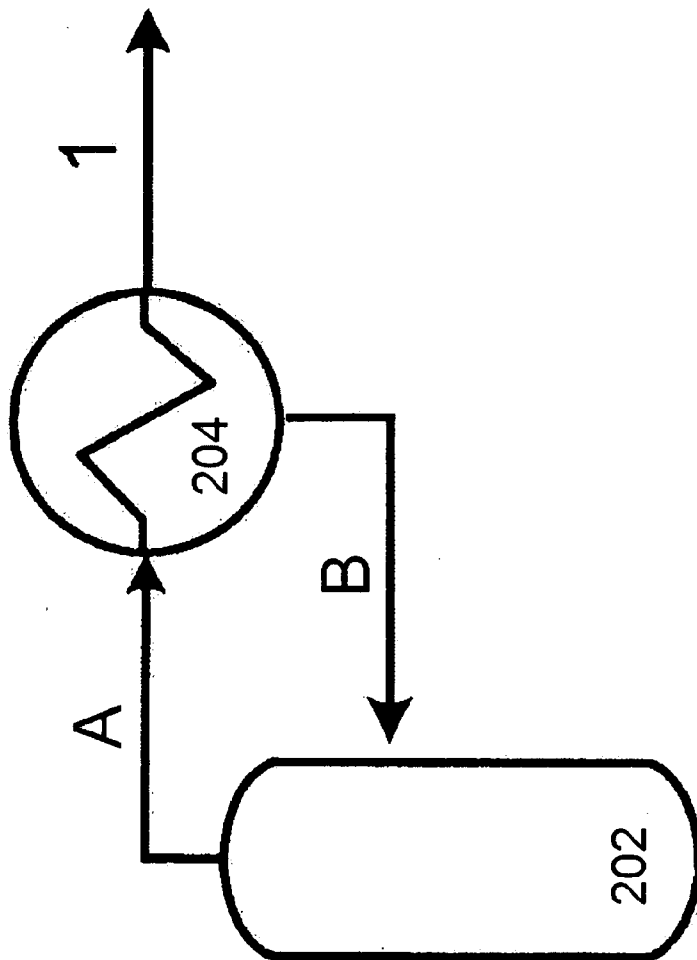
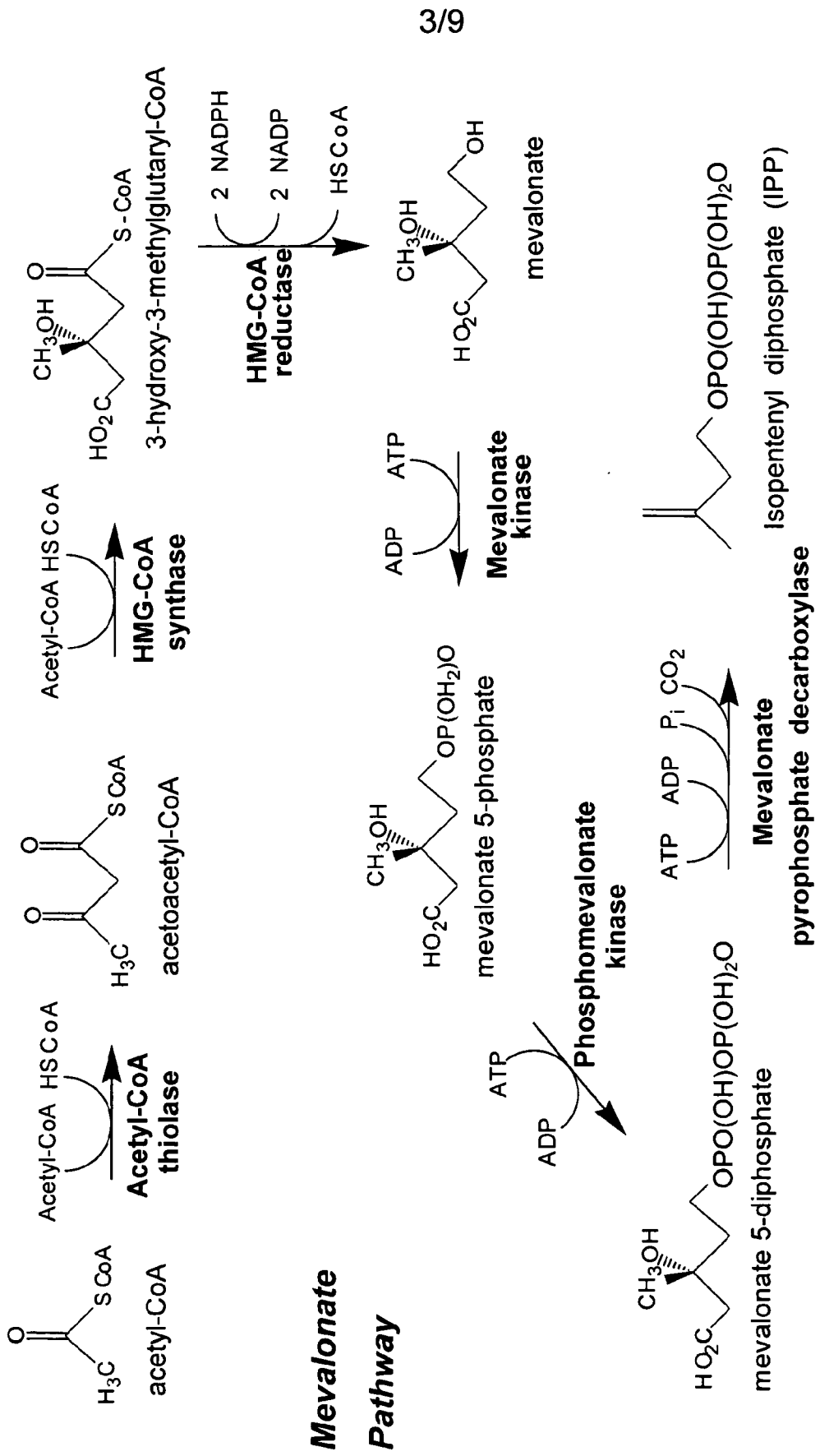
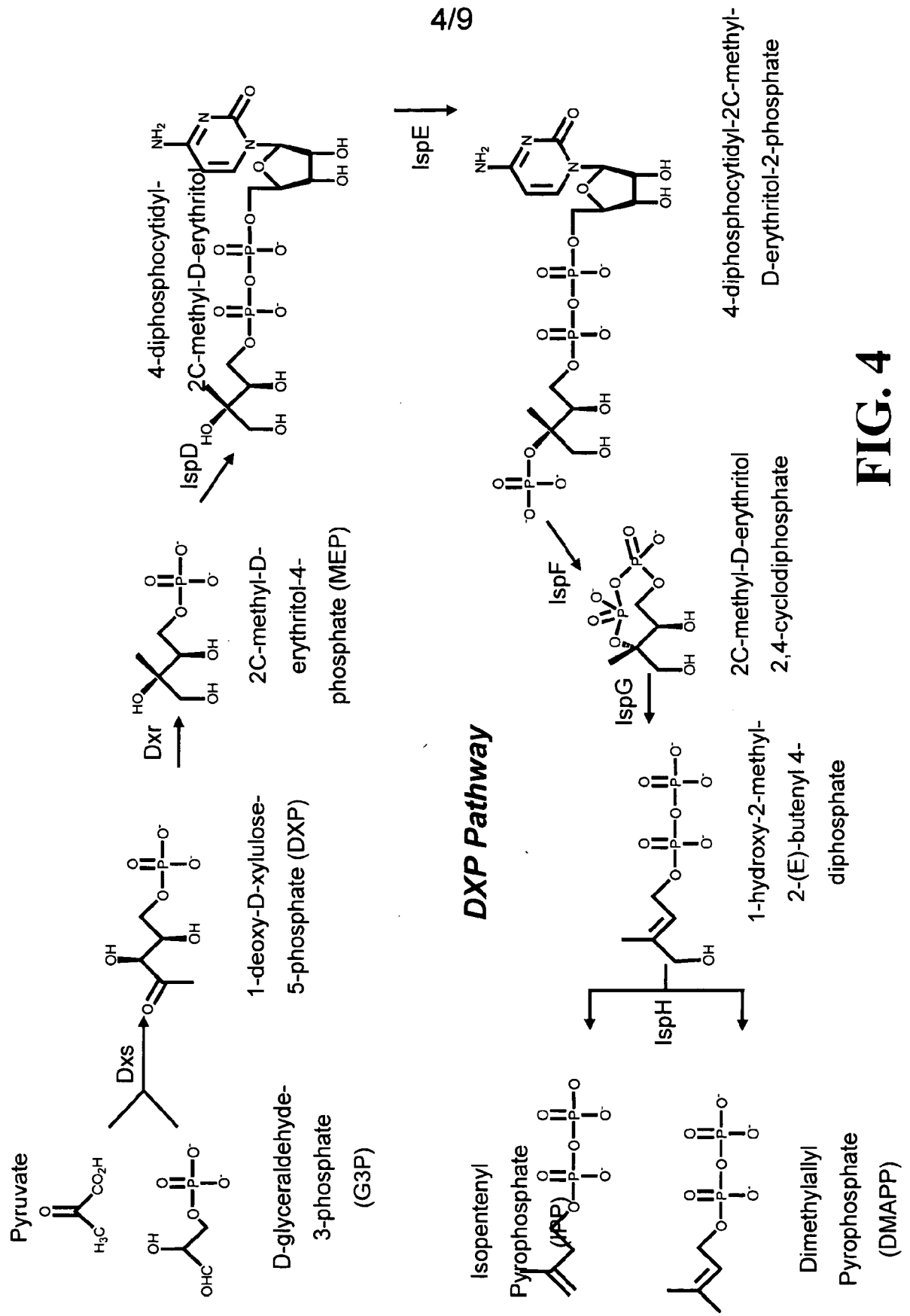

FIG. 2



**FIG. 3**



**FIG. 4**

FIG. 5

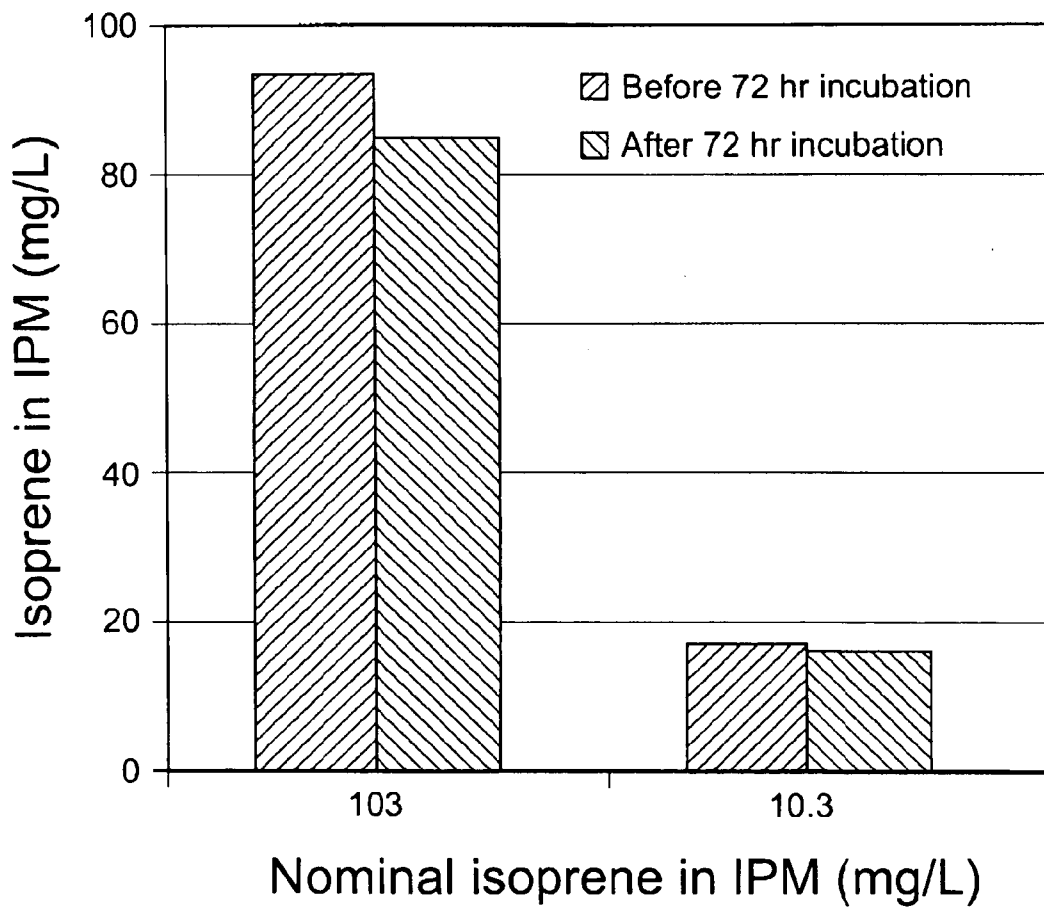

FIG. 6

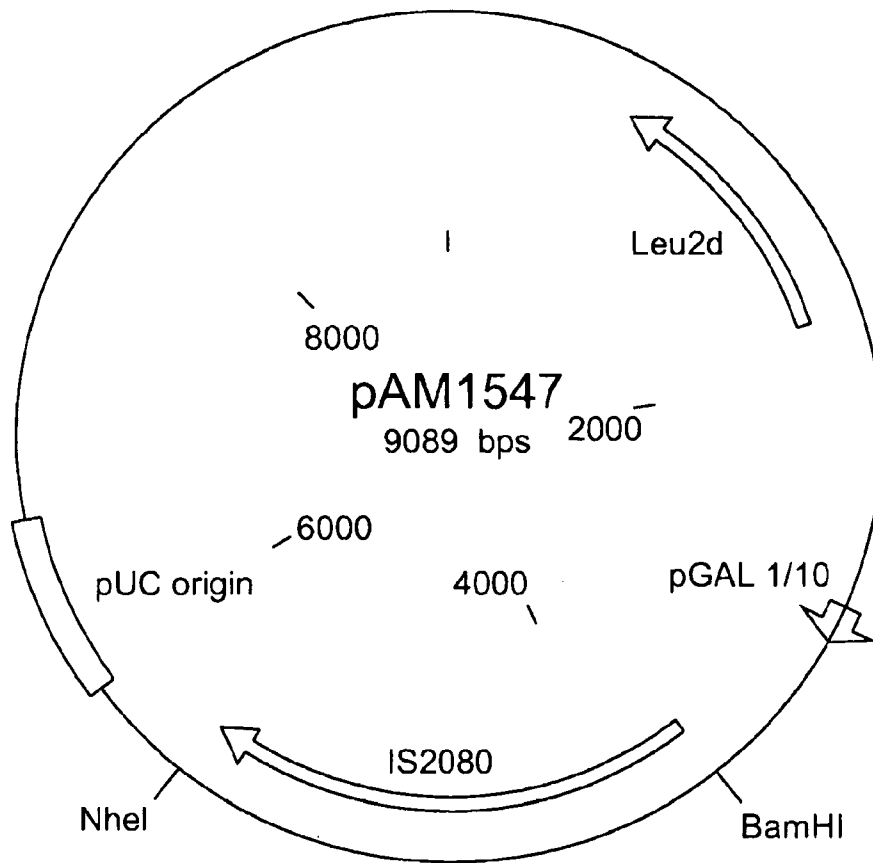

FIG. 7A

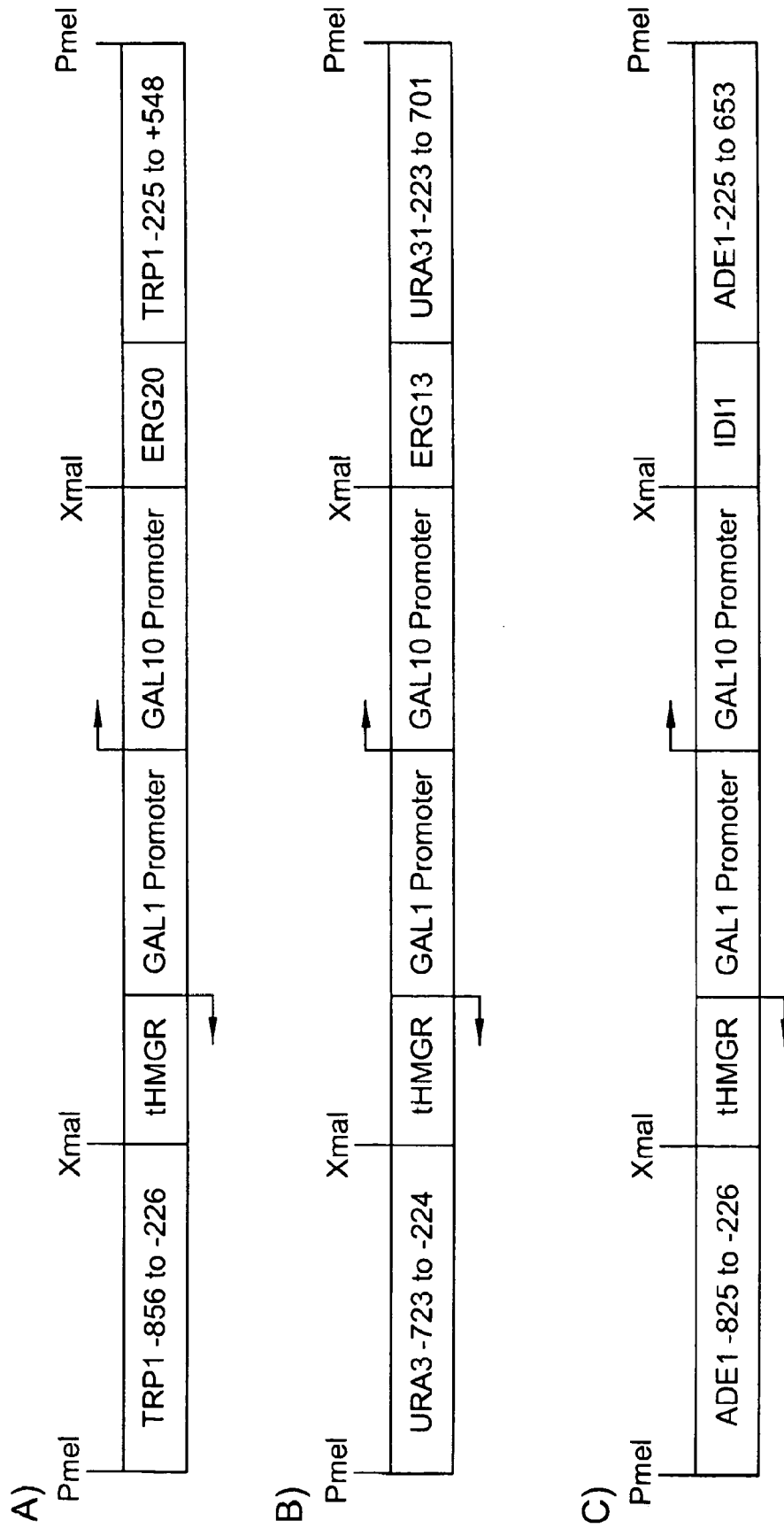

FIG. 7B

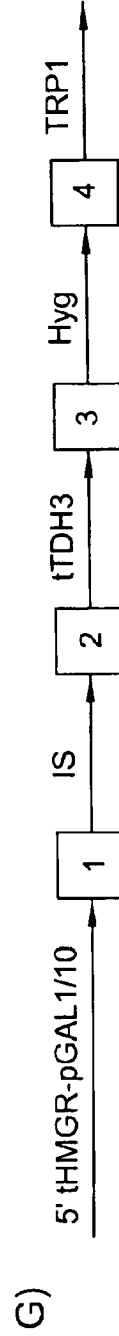
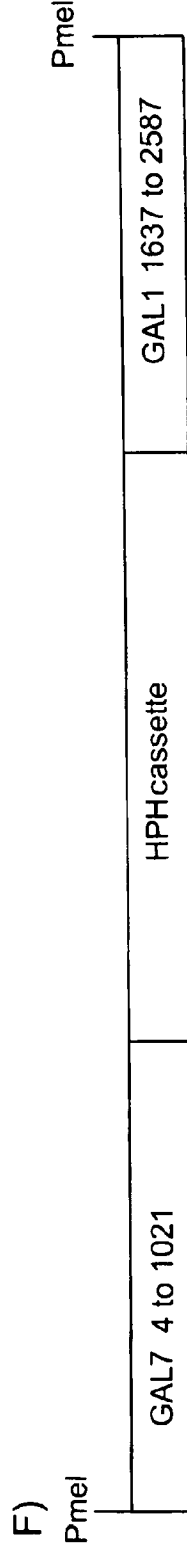
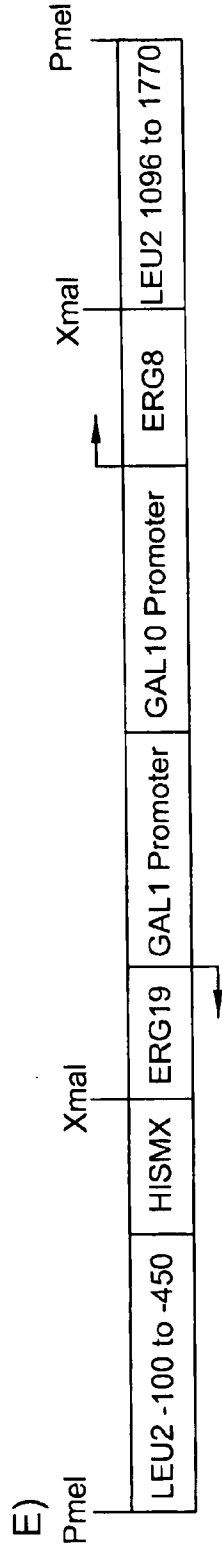
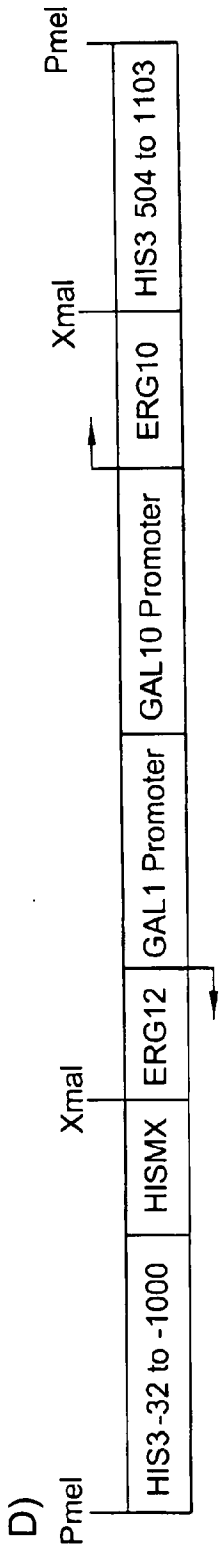

FIG. 8

