

(19) World Intellectual Property Organization
International Bureau



(43) International Publication Date
25 January 2001 (25.01.2001)

PCT

(10) International Publication Number
WO 01/06594 A1

- (51) International Patent Classification⁷: H01Q 1/24, 5/00, 9/04
- (21) International Application Number: PCT/SE00/01486
- (22) International Filing Date: 13 July 2000 (13.07.2000)
- (25) Filing Language: English
- (26) Publication Language: English
- (30) Priority Data: 9902728-6 16 July 1999 (16.07.1999) SE
- (71) Applicant (for all designated States except US): SMARTEQ WIRELESS AB [SE/SE]; Box 4064, S-182 04 Enebyberg (SE).
- (72) Inventor; and
- (75) Inventor/Applicant (for US only): GUSTAFS, Roger [SE/SE]; Norrgårdsvägen 27, S-184 36 Åkersberga (SE).
- (74) Agents: KARLSSON, Leif et al.; L.A. Groth & Co. KB, Västmannagatan 43, S-102 32 Stockholm (SE).
- (81) Designated States (national): AE, AG, AL, AM, AT, AT (utility model), AU, AZ, BA, BB, BG, BR, BY, BZ, CA, CH, CN, CR, CU, CZ, CZ (utility model), DE, DE (utility model), DK, DK (utility model), DM, DZ, EE, EE (utility model), ES, FI, FI (utility model), GB, GD, GE, GH, GM, HR, HU, ID, IL, IN, IS, JP, KE, KG, KP, KR, KZ, LC, LK, LR, LS, LT, LU, LV, MA, MD, MG, MK, MN, MW, MX, MZ, NO, NZ, PL, PT, RO, RU, SD, SE, SG, SI, SK, SK (utility model), SL, TJ, TM, TR, TT, TZ, UA, UG, US, UZ, VN, YU, ZA, ZW.
- (84) Designated States (regional): ARIPO patent (GH, GM, KE, LS, MW, MZ, SD, SL, SZ, TZ, UG, ZW), Eurasian patent (AM, AZ, BY, KG, KZ, MD, RU, TJ, TM), European patent (AT, BE, CH, CY, DE, DK, ES, FI, FR, GB, GR, IE, IT, LU, MC, NL, PT, SE), OAPI patent (BF, BJ, CF, CG, CI, CM, GA, GN, GW, ML, MR, NE, SN, TD, TG).
- Published:
— With international search report.
- For two-letter codes and other abbreviations, refer to the "Guidance Notes on Codes and Abbreviations" appearing at the beginning of each regular issue of the PCT Gazette.

(54) Title: A DUAL BAND ANTENNA DEVICE AND AN ANTENNA ASSEMBLY

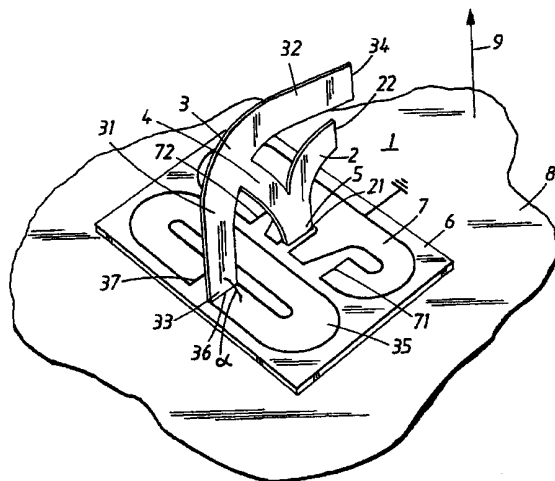

(57) Abstract: The present invention relates to a multiple frequency band antenna means for transmitting and/or receiving RF signals. The antenna means comprising a ground plane means arranged to be connected to ground of a circuitry of a radio communication device and a conductive radiating structure (2, 3 and 4) having a first arm (2) and a second arm (3). Said second arm (3) having a length different from that of the first arm (2). Said first arm (2) and said second arm (3) being electrically connected by a bridge (4), where said bridge (4) being means for matched feeding of said second arm (3) at a second frequency. A dielectric is separating said radiating structure (2, 3 and 4) and said ground plane means. A first end (21) of said first arm (2) being a feed portion (5) and a second end (22) of said first arm (2) being a free end. A first end (33) of said second arm (3) being electrically connected to a frequency tuning arm (35) for said second frequency in said second arm (3) and a second end (34) of said second arm (3) being a free end, where said first and second arms (2 and 3) are forming an angle with said frequency tuning arm (35).



WO 01/06594 A1

A DUAL BAND ANTENNA DEVICE AND AN ANTENNA ASSEMBLY**FIELD OF THE INVENTION**

The present invention relates to an antenna means according to the preamble in claim 1.

5 DESCRIPTION OF THE RELATED ART

With the recent rapid progress of electronic communication technique, communication apparatuses having a higher function and smaller size have been developed and utilized for various kinds of mobile communication apparatuses.

10 Antenna means transmitting and receiving RF-signals on multiple separate frequency bands are known. Dual band antennas according to the state of the art demands generally a quite large amount of space, which make them unpractical for use where there is a need for small and efficient antenna means. A further
15 disadvantage with dual band antennas according to the state of the art is that its manufacture is rather complicated due to its construction.

For example, WO 98/44587 discloses an dual frequency band antenna. Said antenna comprising a first and second arm each
20 excited with separate frequency bands. The first and second arms are coplanar and parallell with a ground plane and a dielectric substrate in between said ground plane and said first and second arm of the antenna means.

This kind of antenna has the disadvantage of not having full
25 omnidirectional radiation pattern which will limit its field of application.

SUMMARY OF THE INVENTION

It is an object of the present invention to provide an antenna means which overcomes or at least reduces some of the above mentioned disadvantages.

5 According to the present invention there is provided an antenna means as claimed in claim 1.

One advantage with the present invention is that the antenna means can be easily implemented because of its simple construction.

10 Another advantage with the present invention is that independent trimming of both bands can be performed in a simple manner.

A further advantage with the invention is that the antenna is having relatively small dimension.

15 Yet another advantage with the present invention is that the different parts of the antenna can easily be stored.

Yet another advantage with the present invention is that a ground plane structure is having a small physical volume.

Yet another advantage with the present invention is that the antenna is relatively simple to manufacture.

20 Yet another advantage with the present invention is that the antenna is relatively simple to assemble.

The invention will now be described in more detail with reference to preferred embodiments thereof and also with reference to the accompanying drawings.

25

BRIEF DESCRIPTION OF THE DRAWINGS

Figure 1 shows an antenna device according to the invention.

Figure 2 shows schematically the current flows of the antenna device of figure 1.

Figure 3 shows an antenna assembly including an antenna device
5 according to the invention.

DESCRIPTION OF A PREFERRED EMBODIMENT

In this disclosure it is to be understood that the antenna
10 system of the invention is operable to receive and/or transmit radio signals. Even if a term is used herein that suggests one specific signal direction it is to be appreciated that such a situation can cover that signal direction and/or its reverse.

15 With reference to Figure 1, an embodiment of an antenna device 1 according to the invention is shown. The antenna device is arranged for transmission/reception of RF waves in two frequency bands, e.g. in the 900 MHz and 1800 MHz bands. The antenna device 1 is to be connected to a radio communication
20 device (not shown), preferably portable, and/or arranged on (in) a vehicle. As shown in the figure, the antenna device 1 is arranged on a conductive part 8, such as a vehicle body. This conductive part 8 will act as a ground plane. The conductive part 8 can be omitted or replaced by conductive portions of a
25 radio communication device, e.g. a PCB (printed circuit board). In those cases the antenna device 1 can be attached to a radio communication device, such as a radio telephone or a computer.

The antenna device 1 comprises a radiating structure 2, 3, 4
30 including a radiating first arm 2 for transmission/reception of RF waves in a first, higher frequency band, and a radiating second arm 3 for transmission/reception of RF waves in a second, lower frequency band. The first 2 and second 3 arms are conductively connected with a bridge 4. The radiating structure
35 2, 3, 4 is to be connected to a transmission line at a feed

portion 5. The feed line is connected to transceiver circuits of a radio communication device. The first arm 2 has a first end 21, in the vicinity of which the feed portion 5 is arranged. A second end 22 of the first arm 2 is a free end. The distance between the first 21 and the second 22 ends along the arm is about $\lambda_1/4$, where λ_1 is the wavelength of the first frequency band. The first arm 2 can easily be tuned to its frequency by adjusting said distance between the ends 21 and 22, e.g. by cutting at the second end 22.

The second arm 3 comprises a first portion 31 and a second portion 32. The bridge 4 connects the second arm 3, between the first portion 31 and the second portion 32, to the first arm 2 in connection with the feed portion 5. The second arm 3 is fed from the feed portion 5 via the bridge 4. The second arm 3 has a first end 33 at an end of the first portion 31. A second end 34, which is a free end of the second arm 3, is arranged at the second portion 32. The distance between the first 33 and the second 34 ends, along the second arm 3, is preferably about $\lambda_2/4$, where λ_2 is the wavelength of the second frequency band. The second arm 3 can easily be tuned to its frequency by adjusting the distance between the ends 33 and 34, e.g. by cutting at the second end 34.

The radiating structure 2, 3, 4 is arranged on a dielectric substrate 6. The dielectric substrate carries a C-shaped, or meandering conductive pattern 35 having a first end 36 and a second end 37. The first end 36 of the conductive pattern 35 is conductively connected with the first end 33 of the second radiating arm 3. In the figure, the conductive pattern 35 is arranged on the same side of the dielectric substrate 6 as the radiating structure 2, 3, 4. The conductive pattern 35 can however be arranged on the opposite side of the dielectric substrate 6. In that case the second radiating arm 3 can be provided with connection pins passing through holes in the

substrate 6 and the pattern 35. The pins are then preferably soldered to the pattern 35. Such pins can be present even if the conductive pattern 35 is arranged on the same side of the dielectric substrate 6 as the radiating structure 2, 3, 4, in order to facilitate the mounting of the radiating structure 2, 3, 4. The length of the conductive pattern 35, i.e. the distance between the first end 36 and the second end 37 along the arm, is selected or adjusted for tuning of the second radiating arm 3 to a desired frequency. This distance is preferably about $\lambda_2/4$, where λ_2 is the wavelength of the second frequency band.

The dielectric substrate 6 is further provided with a ground plane 7 in the form of a generally C-shaped conductive pattern 7, preferably having portions at least partially surrounding a region of the dielectric substrate 6 supporting the radiating structure 2, 3, 4, in the vicinity of the feed portion 5, making the pattern more E-shaped. The C-shaped conductive pattern 7 is connected to ground of the transceiver circuits of the radio communication device, preferably by connection to the ground of the transmission line. The generally C-shaped conductive pattern 7 has a first 71 and a second 72 end. Preferably the length of the C-shaped conductive pattern 7 i.e. the distance between the first 71 and second 72 ends along the pattern is essentially $\lambda_1/2$, where λ_1 is the wavelength of the first (higher) frequency band. This ground plane 7 is sufficient for the antenna function, and the antenna device 1 can be mounted to a portable radio communication device. However, if the antenna device 1 is mounted on a vehicle roof or body, conductive portions 8 of the vehicle are coupled, preferably capacitively, to the ground plane 7. In this case the conductive portions 8 also act as ground plane. If mounted on (in) a portable radio communication device, such as a hand portable radio telephone, conductive portions e.g. a PCB of the radio communication device can be coupled, preferably

capacitively, to the ground plane 7, whereby those conductive portions also are acting as ground plane.

5 Since the conductive pattern 35 for the frequency tuning in the second (lower) frequency band and the ground plane 7 in the form of a generally C-shaped conductive pattern 7 are located adjacent to each other there will be a capacitive coupling between the two patterns. This coupling can be adjusted for achieving the desired antenna performance. Preferably the
10 coupling can be made stronger if the conductive portions 8 or their equivalence is omitted.

The radiating structure 2, 3, 4 is shown to be arranged in a plane perpendicular to the dielectric substrate 6 and its
15 conductive patterns 7, 35. However the radiating structure 2, 3, 4 can be arranged in a plane intersecting the plane of the dielectric substrate 6 at another angle α , depending on the application and the available space. This could also be expressed as where a tangent to a direction of extension of the
20 second arm at the first end forms an angle α with a tangent of a direction of extension of the tuning arm at the connection portion, which also is applicable if the radiation structure is not planar. The angle α can e.g. be in the range 45° - 135° , preferably 90° .

25 The radiating structure 2, 3, 4 is preferably manufactured by stamping or cutting out the structure from a conductive plate e.g. metal plate. The arms 2 and 3 and the bridge are preferably given band shapes, i.e. the width of the arms and
30 bridge in the plane of the structure is essentially larger than the thickness (perpendicular to the plane of the structure). The conductive pattern 35 for the frequency tuning in the second (lower) frequency band and the ground plane 7 in the form of a generally C-shaped conductive pattern 7 are formed on

the dielectric substrate by printing, etching, depositing or similar. Preferably the radiating structure 2, 3, 4 is formed with guiding and possibly connections pins at the end 21 and connecting and guiding pins at the end 33. The dielectric
5 substrate 6 and the conductive pattern 35 are then provided with holes for reception of said pins. The pins and/or the ends 21 and 33 are glued or soldered to the dielectric substrate 6 and the conductive pattern 35.

10 In Figure 2 the current flows in the antenna device of figure 1 is shown schematically by arrows. As seen, the currents in the bridge 4 and the first portion 31 of the second arm 3 flows in the same direction. The first portion 31 is the part of the antenna device that radiates most in the second (lower)
15 frequency band, and the bridge 4 radiates less but substantially. The currents in the conductive pattern 35 for the frequency tuning in the second (lower) frequency band are directed in opposite directions resulting in almost no radiating from this pattern 35. For the first frequency band
20 (higher) the arm 2 will perform the essential radiation. Arrow 9 indicates the direction of polarization for the RF waves radiated from the radiating structure 2, 3 and 4.

Figure 3 shows an antenna assembly 10 especially adapted for
25 mounting on a vehicle body, e.g. on the roof. The antenna device 1, which includes the radiating structure 2, 3, 4, the conductive pattern 35 for the frequency tuning in the second (lower) frequency band and the ground plane 7 in the form of a generally C-shaped conductive pattern 7, is mounted on a base
30 11. A GPS antenna 12 is also mounted on the base 11. In the center portion of the base 11 is a hole arranged for feeding through cables. A clamp 13 is arranged on the PCB for clamping a coaxial antenna cable 14, making electrical contact with the outer conductor of said cable, and being connected to the
35 generally C-shaped conductive pattern 7 on the back side (not

shown). The center conductor of the coaxial cable is connected to the PCB 6. The PCB 6 is, on the back side (not shown), provided with a pattern interconnecting the center conductor of the coaxial cable 14 and the feed portion 5 of the radiating structure 2, 3, 4, via guiding and connection pins arranged on the first end 21 of the first arm. Also the conductive pattern 35 for the frequency tuning in the second (lower) frequency band is arranged on the back side of the PCB and is connected to the second arm by means of guiding and connection pins, as described above. The assembly is covered and protected by a housing 15. For supporting the radiating structure 2, 3, 4, a strut 16 is attached to the radiating structure 2, 3, 4 and the PCB 6. The strut 16 is preferably made of dielectric material.

Said first and second arms of the antenna means can be substantially band shaped. Said band shaped first and second arms of the antenna means can have substantially the same thickness. Said band shaped first and second arm of the antenna means can have substantially the same width. Said width of the band shaped first and second arm of the antenna means can be smaller than the length of respective section.

Alternatively the radiating structure 2, 3 and 4 can be arranged on or in a dielectric substrate. The frequency tuning arm 35 and the ground plane structure 7 can alternatively be manufactured by stamping or cutting out the structure from a metal plate. Said frequency tuning arm and ground plane structure can be glued to a dielectric substrate.

Alternatively the thickness and/or width can be different for different portions of the radiating structure 2, 3, 4.

CLAIMS

1. An antenna means for transmitting and/or receiving RF signals in at least a first and a second frequency band, comprising:
- 5
- a ground plane means arranged to be connected to ground of a circuitry of a radio communication device,
 - a conductive radiating structure (2, 3 and 4) having a first arm (2) and a second arm (3),
 - 10 - said second arm (3) having a length different from that of the first arm (2),
 - said first arm (2) and said second arm (3) being electrically connected by a bridge (4), where said bridge (4) being means for matched feeding of said second arm (3) at the second frequency band,
 - 15 - a dielectric separating said radiating structure (2, 3, and 4) and said ground plane means, characterized in that a first end (21) of said first arm (2) being a feed portion (5) and a second end (22) of said first arm (2) being a free end, a first end (33) of said second arm (3) being electrically connected to a connection portion of a frequency tuning arm (35) for said second frequency in said second arm (3) and a second end (34) of said second arm (3) being a free end, where a tangent to a direction of extension of the second arm (3) at the first end (33) forms an angle (α) with a tangent of a direction of extension of the frequency tuning arm (35) at the connection portion.
 - 20
 - 25
2. The antenna means according to claim 1, characterized in that said free end (22) of said first arm (2) being means for tuning a first frequency.
- 30

3. The antenna means according to claim 1 or 2, characterized in that said free end (34) of said second arm (3) and a free end (37) of said frequency tuning arm (35) being means for tuning said second frequency.
- 5 4. The antenna means according to any of the claims 1-3, characterized in that said ground plane means being a ground plane structure (7) having a length of essentially $\lambda/2$ at said first frequency.
- 10 5. The antenna means according to any of the claims 1-4, characterized in that said first arm (2) having a length of essentially $\lambda/4$ at said first frequency.
6. The antenna means according to any of the claims 1-5, characterized in that said second arm (3) having a length of essentially $\lambda/4$ at said second frequency.
- 15 7. The antenna means according to any of the claims 1-6, characterized in that said frequency tuning arm (35) having a length of essentially $\lambda/4$ at said second frequency.
- 20 8. The antenna means according to any of the claims 4-7, characterized in that a capacitive coupling is established between said frequency tuning arm (35) and said ground plane structure (7) for stabilizing said second frequency.
- 25 9. The antenna means according to any of the preceding claims, characterized in that said angle (α) between the tangent to a direction of extension of the second arm (3) at the first end (33) and a tangent of a direction of extension of the frequency tuning arm (35) at the connection portion is an angle in the interval of 45°-
30 135°.

10. The antenna means according to any of the claims 1-9, characterized in that at least one of the arms (2 or 3) in the conductive radiating structure and/or the frequency tuning arm (35) is meander shaped.
- 5 11. The antenna means according to any of the claims 4-10, characterized in that said frequency tuning arm (35) and said ground plane structure (7) are conductive patterns arranged on a dielectric substrate (6).
- 10 12. The antenna means according to claim 11, characterized in that said conductive patterns are arranged on one side of the dielectric substrate (6).
13. The antenna means according to claim 11, characterized in that the conductive patterns are arranged inside the dielectric substrate (6).
- 15 14. The antenna means according to any of the preceding claims, characterized in that the frequency tuning arm (35) is essentially C-shaped and where the first end (33) of said second arm (3) is connected to one end of said essentially C-shaped frequency tuning arm (35).
- 20 15. The antenna means according to any of the preceding claims, characterized in that the ground plane structure (7) is essentially E-shaped with said connection to ground of said circuitry of said radio communication device in the middle of said E-shaped structure.
- 25 16. The antenna means according to any of the preceding claims, characterized in that said bridge (4) connecting said first arm (2) electrically to said second arm (3) is arranged between said first and second end on said first and second arm respectively.
- 30 17. The antenna means according to claim 16, characterized in that the bridge (4) is arranged substantially at the same distance from said first and second ends of the second arm and arranged closer to the feed portion than the free end of the first arm.

18. The antenna means according to any of the preceding claims, characterized in that said first and second arms (2 and 3) are substantially band shaped.
- 5 19. The antenna means according to claim 18, characterized in that said band shaped first and second arms (2 and 3) having substantially the same thickness.
20. The antenna means according to claim 18, characterized in that said band shaped first and second arm (2 and 3) having substantially the same width.
- 10 21. The antenna means according to claim 18, characterized in that said band shaped first arm (2) having a different thickness compared to said second arm (3).
22. The antenna means according to claim 18, characterized in that said band shaped first arm (2) having a
15 different width compared to said second arm (3).
23. The antenna means according to any of the claims 18-22, characterized in that the width of the band in each arm (2, 3 and 35) is smaller than the length of respective section.
- 20 24. The antenna means according to any of the preceding claims, characterized in that the radiating structure (2, 3 and 4) and/or the tuning arm and/or the ground plane structure are arranged on or in a dielectric substrate (6).
- 25 25. The antenna means according to any of the preceding claims, characterized in that the radiating structure and/or the tuning arm (35) and/or the ground plane structure (7) are made out of a conductive plate.
- 30 26. The antenna means according to any of the claims 9-25, characterized in that said angle (α) being an angle of 90° .
27. An antenna assembly (10) including an antenna means (1) according to any preceding claim, wherein the assembly (10) comprises at least one further radiating structure

(12) for at least receiving circularly polarized radio frequency signals, for instance, a GPS antenna.

Fig. 3

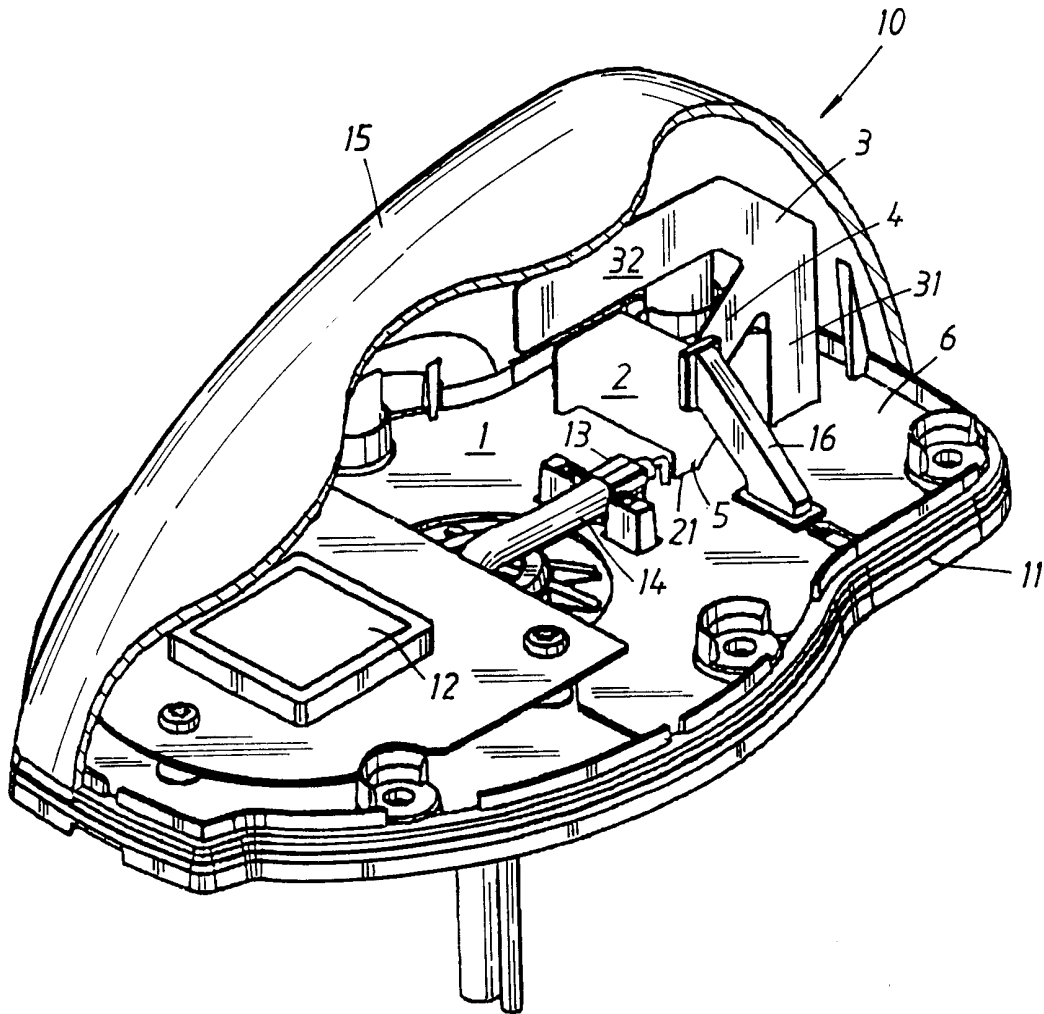

INTERNATIONAL SEARCH REPORT

International application No.
PCT/SE 00/01486

A. CLASSIFICATION OF SUBJECT MATTER

IPC7: H01Q 1/24, H01Q 5/00, H01Q 9/04

According to International Patent Classification (IPC) or to both national classification and IPC

B. FIELDS SEARCHED

Minimum documentation searched (classification system followed by classification symbols)

IPC7: H01Q

Documentation searched other than minimum documentation to the extent that such documents are included in the fields searched

SE,DK,FI,NO classes as above

Electronic data base consulted during the international search (name of data base and, where practicable, search terms used)

C. DOCUMENTS CONSIDERED TO BE RELEVANT

Category*	Citation of document, with indication, where appropriate, of the relevant passages	Relevant to claim No.
A	WO 9844587 A1 (QUALCOMM INCORPORATED), 8 October 1998 (08.10.98) --	1-27
A	WO 9844588 A1 (QUALCOMM INCORPORATED), 8 October 1998 (08.10.98) -- -----	1-27

Further documents are listed in the continuation of Box C.

See patent family annex.

* Special categories of cited documents:

"A" document defining the general state of the art which is not considered to be of particular relevance

"E" earlier document but published on or after the international filing date

"L" document which may throw doubts on priority claim(s) or which is cited to establish the publication date of another citation or other special reason (as specified)

"O" document referring to an oral disclosure, use, exhibition or other means

"P" document published prior to the international filing date but later than the priority date claimed

"T" later document published after the international filing date or priority date and not in conflict with the application but cited to understand the principle or theory underlying the invention

"X" document of particular relevance: the claimed invention cannot be considered novel or cannot be considered to involve an inventive step when the document is taken alone

"Y" document of particular relevance: the claimed invention cannot be considered to involve an inventive step when the document is combined with one or more other such documents, such combination being obvious to a person skilled in the art

"&" document member of the same patent family

Date of the actual completion of the international search

5 October 2000

Date of mailing of the international search report

27 -10- 2000

Name and mailing address of the ISA/

Swedish Patent Office

Box 5055, S-102 42 STOCKHOLM

Facsimile No. +46 8 666 02 86

Authorized officer

Rune Bengtsson/AE

Telephone No. +46 8 782 25 00

INTERNATIONAL SEARCH REPORT
Information on patent family members

International application No.
PCT/SE 00/01486

Patent document cited in search report			Publication date	Patent family member(s)		Publication date
WO	9844587	A1	08/10/98	AU	6869898 A	22/10/98

WO	9844588	A1	08/10/98	AU	6584698 A	22/10/98
