



INTERNATIONAL APPLICATION PUBLISHED UNDER THE PATENT COOPERATION TREATY (PCT)

<p>(51) International Patent Classification ⁵ : F04F 05/44</p>	<p>A1</p>	<p>(11) International Publication Number: WO 93/11362</p> <p>(43) International Publication Date: 10 June 1993 (10.06.93)</p>
<p>(21) International Application Number: PCT/US91/08839</p> <p>(22) International Filing Date: 27 November 1991 (27.11.91)</p> <p>(71)(72) Applicant and Inventor: COSSAIRT, Keith, R. [US/US]; 150 Oak Ridge Place, Apartment 7B, Greenville, SC 29615 (US).</p> <p>(74) Agent: HARDAWAY, John, B., III; Bailey & Hardaway, 125 Broadus Ave., Greenville, SC 29601 (US).</p> <p>(81) Designated States: AU, BR, CA, JP, SU, European patent (AT, BE, CH, DE, DK, ES, FR, GB, GR, IT, LU, NL, SE), OAPI patent (BF, BJ, CF, CG, CI, CM, GA, GN, ML, MR, SN, TD, TG).</p>		<p>Published <i>With international search report.</i> <i>With amended claims.</i></p>
<p>(54) Title: FLUID DYNAMIC PUMP</p> <div data-bbox="383 1187 1244 1814" style="text-align: center;"> </div> <p>(57) Abstract</p> <p>The invention relates to a pumping apparatus and a process for pumping a fluid media. The apparatus includes a conduit having an entrance for pumped fluid (24) and an exit for the pumped fluid (26). The conduit is formed by an outer shell (32) and an inner shell (34) which is connected to the outer shell. A throat (36) is attached to the outer shell (32) and forms the exit portion of the conduit. One end of the throat portion defines an annular surface (30) which is spaced from the inner shell (34) to define a primary exhaust orifice (37) of thickness "t". The process includes forcing a primary fluid through the primary exhaust orifice (37) to induce a flow of pumped fluid through the conduit.</p>		

FOR THE PURPOSES OF INFORMATION ONLY

Codes used to identify States party to the PCT on the front pages of pamphlets publishing international applications under the PCT.

AT	Austria	FR	France	MR	Mauritania
AU	Australia	GA	Gabon	MW	Malawi
BB	Barbados	GB	United Kingdom	NL	Netherlands
BE	Belgium	GN	Guinea	NO	Norway
BF	Burkina Faso	GR	Greece	NZ	New Zealand
BG	Bulgaria	HU	Hungary	PL	Poland
BJ	Benin	IE	Ireland	PT	Portugal
BR	Brazil	IT	Italy	RO	Romania
CA	Canada	JP	Japan	RU	Russian Federation
CF	Central African Republic	KP	Democratic People's Republic of Korea	SD	Sudan
CG	Congo	KR	Republic of Korea	SE	Sweden
CH	Switzerland	KZ	Kazakhstan	SK	Slovak Republic
CI	Côte d'Ivoire	LJ	Liechtenstein	SN	Senegal
CM	Cameroon	LK	Sri Lanka	SU	Soviet Union
CS	Czechoslovakia	LU	Luxembourg	TD	Chad
CZ	Czech Republic	MC	Monaco	TG	Togo
DE	Germany	MG	Madagascar	UA	Ukraine
DK	Denmark	ML	Mali	US	United States of America
ES	Spain	MN	Mongolia	VN	Viet Nam
FI	Finland				

5

FLUID DYNAMIC PUMP

BACKGROUND OF THE INVENTION

This invention generally relates to pumps, and more particularly, to a new concept in pumps where the principle of operation is based upon the change in momentum of a fluid jet
10 curtain.

Inasmuch as this invention encompasses a broad range of art, reference is made to six (6) specific fields in order to review some prior-art areas where this invention has impact:

a. Fans and blowers; Characterized by high volume flow at
15 low static pressures. Fans and blowers typically contain a rotating member which imparts velocity (momentum) to a media. The media must be relatively clean or this rotating member will become damaged or out of balance. The range of operation is limited and the media is essentially limited
20 to atmospheric air.

b. Centrifugal Pumps; Characterized by high static pressures and relatively low flow rates.

Centrifugal pumps typically contain a rotating member which imparts velocity (momentum) to the media via the
25 action of a centrifugal force. The media must be relatively clean or the rotating member will become clogged or damaged. The range of operation is limited, although hybrid and/or compound devices (mixed flow) can increase the operating range for a significant cost.

- 2 -

c. Suction Pumps; Characterized by moderate flow rates and low static pressures at the pump inlet (negative gage pressure).

5 Suction pumps typically contain an enclosed rotating member which is designed to ingest moderate amounts of foreign matter. Suction pumps are designed to be disassembled and the worn parts replaced and/or rebuilt periodically. This constitutes an added cost to the operation of this unit.

10 d. Ejectors; Characterized by a high pressure source of primary fluid for power and a specially designed shroud.

15 Ejectors are inexpensive, durable, maintenance free and lightweight. Ejectors, however, have a small operating range, are the least efficient of all pumps, and are very sensitive to back pressure (static head that it can pump against). Additionally, since ejectors depend on viscous entrainment and turbulent mixing to accomplish the momentum exchange between the primary driving fluid and the secondary media, the amount and type of foreign matter ingested is

20 very important.

e. Jet Propulsion; Characterized by devices such as ram jets, pulse jets and under-water jets (specifically excluding axial flow, multi-stage gas turbines as exemplified in modern jet aircraft).

25 Jet propulsion devices, as listed herein, have received considerable attention primarily because of their inherent

- 3 -

simplicity. However, in spite of the considerable research and development efforts made with regard to these concepts, significant room for improvement exists.

5 Consider first the ram jet: Ram jets exhibit deficiencies in their ability to develop static thrust and consume excessive quantities of fuel. Limited use of the ram jet has occurred in very specialized military applications.

10 Consider next the pulse jet: While the pulse jet is capable of generating static thrust, the low efficiency, short lived valves (reeds) and extremely high noise levels has prevented any known use. This is the jet engine of the notorious V1 Buzz Bomb of World War II.

15 Finally, consider other devices such as the an underwater jet propulsion engine which uses compressed air through a porous wall to simulate combustion; thereby expelling the water through an exhaust nozzle and generating thrust. This engine has the same deficiencies as the ramjet, with regard to static thrust and efficiency plus
20 other negative characteristics.

f. Combustion Burners; Such devices are of a very mature engineering design, being the recipient of over 100 years of design, development and use. In spite of this fact, no know effort has been successful in increasing the pressure
25 ratio of combustion (increasing the static pressure of combustion).

While many areas of application of this invention have been reviewed above, it is apparent that a need exists within the prior art for improvement.

SUMMARY OF THE INVENTION

5 It is thus an object of this invention to provide a novel method and apparatus for pumping fluids.

It is a further and more particular objects of this invention to provide such a novel method and apparatus which is applicable to a wide field of endeavor.

10 It is thus a further and yet more particular object of this invention to provide a novel pumping method and apparatus which has application to fans and blowers, centrifugal pumps, suction pumps, ejectors, jet propulsions, combustion burners, robotics, fluidics and other fields of endeavor.

15 These, as well as other objects, are accomplished by conduit means having an entrance and an exit, a first annular opening defined within the conduit means for exhausting a fluid media, and a second annular opening about the conduit means for
intaking fluid media. The process is carried out by expelling
20 a fluid medium from the exhaust annular opening, and intaking fluid media into the intaking annular opening thereby causing fluid media to be pumped from the conduit entrance to the conduit exit as a result of a change in momentum of the fluid media transported from the exhaust annular opening to the
25 intake annular opening.

BRIEF DESCRIPTION OF THE DRAWINGS

Figure 1 of the drawings is a partial cutaway view of an apparatus in accordance with this invention.

Figure 2 is a perspective partial cutaway view of the
5 apparatus illustrated in figure 1.

Figures 3A and 3B are schematic illustrations showing flow parameters in accordance with this invention.

Figure 4 is a view similar to figure 1 illustrating an embodiment of this invention.

10 Figure 5 is a view similar to figure 1 identifying physical variables which variables are discussed within the specification.

Figure 6 is a view similar to figure 1 illustrating an embodiment obtaining maximum mass flow rate.

15 Figure 6A is a schematic illustration of an embodiment having multiple staging.

Figure 7 is a view similar to figure 1 illustrating an embodiment suitable for obtaining maximum pressure.

20 Figure 7A is a schematic illustration of an embodiment optimized to obtain high discharge static pressure by multiple staging of the apparatus.

Figure 8 is a view similar to figure 1 illustrating an embodiment for obtaining maximum thrust.

- 6 -

Figure 8A is a schematic illustration of an embodiment integrated into a missile or rocket to provide propulsive thrust.

Figure 9 is a view similar to figure 1 illustrating an embodiment suitable for obtaining maximum suction at the inlet of the apparatus.

Figure 10 is a view similar to figure 1 illustrating an embodiment suitable for obtaining maximum heat of the discharged media at the exit of the apparatus.

Figure 11 is a schematic illustration of an embodiment as it applies to the field of robotics.

Figure 12 is a schematic illustration of an embodiment of the invention as it applies to the field of fluidics.

DETAILED DESCRIPTION

This invention, in its' purest form, creates and sustains a static pressure gradient between two stations in a closed system. The consequence of this is the ability to do work on a fluid by causing it to move (to accelerate a mass in motion), or to compress a static media (increase the static pressure of a fluid at rest). This results in a multitude of potential uses such as: transporting fluids (in conduits); ejecting fluids at a high velocity to create thrust (with or without combustion); compressing the products of combustion thereby increasing the efficiency of combustion and yielding more heat energy; and generating unique features such as a constant

- 7 -

force-vs-position device which has applications in the field of Robotics and as a pneumatic/hydraulic "rectifier" or "gate", which has application in the field of Fluidics.

While this invention may be described herein at different times in terms of aerodynamics and at other times in terms of hydraulics, it should be understood that as herein disclosed, it is equally applicable to all fluids (liquids and gases or mixtures of liquids, gases, various selected solid particles and "fluidized" solids). Further, this invention has virtually no physical size restrictions and even through subsonic velocities are assumed in the preferred embodiment, this invention may also be used where supersonic velocities are encountered.

Accordingly, several objects and advantages of this invention are:

a. Fans and Blowers - This invention, designed specifically for optimum performance in the media and over the operating range of fans and blowers, will operate over a much broader range, is very light weight, and contains no moving parts to wear out or to become damaged or out of balance. It can operate in extreme conditions of temperature, humidity, contamination, mechanical shock, and vibration; and with no moving parts it is safe to use anywhere, especially in hazardous areas and volatile atmospheres.

- 8 -

b. Centrifugal Pumps - This invention, designed specifically for optimum performance in the media and over the operating range of centrifugal pumps, will operate over a much broader range, is very light weight and contains no moving parts to wear out or to become damaged or out of balance. It can operate in extreme conditions of temperature, humidity, contamination, mechanical shock, and vibration; and with no moving parts it is safe to use anywhere, especially in hazardous areas and volatile atmospheres.

c. Suction pumps - Being fundamental to the operation of a suction pump, this invention will be able to ingest large quantities of foreign matter, whether the matter be oil floating on the open sea, debris from the streets of a city, or dredged sand and gravel from the bottom of navigable waterways. The embodiment of this invention as a suction pump will result in a pump of superior performance and lower cost than any known suction pump. Furthermore, it will operate over a wide range of operating conditions and has no moving parts to wear out.

d. Ejectors - The invention provides for optimum performance in the media and over the operating range of an ejector, and operates over a much broader range, is more efficient and will pump against a much larger static head than any known ejector. Additionally, the apparatus of this

- 9 -

invention is smaller in size and is relatively insensitive to the size and character of the foreign matter ingested.

The prior art of ejectors teach that in order for an ejector to function, the primary flow must interact with the secondary flow through viscous entrainment and turbulent mixing, followed by an expansion of the tertiary flow and subsequent exhaust at the design static pressure. The principle of operation of the invention is quite different from that of an ejector. So much so that it makes no difference if the media is viscous or not, in order to pump against a static head. This difference is further apparent in the comparison of the magnitude of static pressures which the ejector and this invention can pump against. Theory and test data indicate that for comparable devices, this invention will pump against a total head which is an order of magnitude higher than that possible with an ejector.

e. Jet Propulsion - The embodiment of the invention results in an engine unlike any other known jet engine. As a "cold" jet engine (without combustion) it has the capability of developing static thrust and a propulsive force while emersed in either air or water. With combustion, the operating range and overall performance in both of these media is considerably extended. Having no moving parts, being extremely durable and reliable, inexpensive and light weight, this device has no known counterpart.

- 10 -

f. Combustion Burners - The embodiment of this invention in the form of a combustion burner results in a burner unlike any other known burner. In this embodiment combustion occurs at a static pressure greater than ambient, thereby increasing the efficiency of combustion and the heat released, thereof.

g. Robotics - This invention contains a unique characteristic in that it is able to generate a constant force, which has application in robotics. No known single device is able to accomplish this without the use of a multiplicity of devices such as pressure sensing/relief valves, accumulators and switches.

h. Fluidics - This invention also contains an additional unique characteristic in that it restricts the flow of a fluid in one direction while allowing free passage or amplifying the flow in the other direction. This is sometimes referred to as a rectifier or gate.

Various other advantages and features will become apparent from the following description given with reference to the various figures and drawings.

Figures 1 and 2 of the drawings illustrate a preferred embodiment of the apparatus and the process carried out by this invention. Figures 3A and 3B schematically illustrate the invention in its simplest form. The apparatus 20 comprises means defining a conduit 22 having an entrance end 24 and an exit end 26. Conduit means 22 has two annular openings defined

- 11 -

and communicating with the interior of the conduit means for controlling flow of fluid media therethrough. A first annular ring 28 permits introduction of a fluid media into the interior of the conduit means 22. A second annular ring 30 which is
5 disposed from the first annular ring toward the exit end 26 of conduit means 22 is for the intake of fluid media. The operation of the fluid media will be further described below.

Figures 1 and 2 illustrate an apparatus in accordance with this invention. The apparatus comprises a hollow bell-like
10 assembly comprising of four parts defining the conduit means 22 and its associated annular rings. An outer shell 32 encompassing most of the entire apparatus is attached to an inner shell 34 on one end. An adjustable throat 36 is provided by way of a threaded fitting on the opposite end. The primary
15 power fluid is constrained in a cavity (plenum) 38 between the outer shell 32, the inner shell 34 and the throat 36. An inlet supply tube 40 communicates with the plenum 38. The attachment between outer shell 32 and inner shell 34 must be with a permanent pressure tight bond or a sealed, leak proof fitting.
20 Likewise, the same is true for the fitting between outer shell 32 and adjustable throat 36. Except for the supply tube 40, the apparatus is axially symmetrical about the longitudinal centerline.

By rotating the adjustable throat 36 with respect to outer
25 shell 32, the annular opening 37 (primary exhaust orifice) between adjustable throat 36 and inner shell 34 is adjusted.

- 12 -

The desired adjustment depends on the media, design considerations and operational factors. In some embodiments this adjustment may be fixed instead of variable. Under this condition, it is possible to construct this embodiment of only
5 one integral part, instead of the four parts referenced.

An added feature such as a locking nut may be threaded on adjustable throat 36 and tightened against the aft end of the said outer shell 32 thereby preventing any accidental movement. This assures that the final adjustment of the throat remains
10 fixed during operation. Other design features such as an inlet grill/screen, rub and chaff guards, the material of construction, and the size and weight may be determined by engineering analysis by one skilled in the art.

Having generally described the apparatus of this invention,
15 the method and parameter of operation will now be described.

Figures 3A and 3B are simplified schematic illustrations jointly showing two extremes of operation - no flow figure 3A and full flow figure 3B. Considering first figure 3A, the fluid media is exhausted from an annular port 28 at station A
20 at an inward angle such that the jet curtain joins together at station B. The flow pattern between A and B is similar to a fluid flowing over the outside of a cone, flowing from a base A to the apex B. Though this invention can perform in a two dimensional configuration, the preferred embodiment is of a
25 three dimensional configuration. Accordingly, visualize the configuration shown in figure 3A and Figure 3B as being axially

- 13 -

symmetrical about the shown centerline. The flow continues on to station C in the form of a cylindrical jet. It is not essential that stations B and C be separated by any given distance. In some embodiments or operating conditions this distance (B to C) may be equal to zero. However, it is important for best efficiency that the fluid curtain reach station C as a uniform, symmetrically shaped jet. At station C the jet parts and forms a shape similar to the conical shape between A and B, except that the jet curtain is curved. The jet curtain subsequently enters the annular port 30 at station D. The reason the jet curtain is curved is because of the static pressure (P_B). The reason for this static pressure comes from the laws of physics. To paraphrase this law for this specific application the pressure-force must be equal and opposite to the change in momentum of the jet, or, the change in momentum of the jet curtain (between stations C and D) must be equal to the pressure gradient across this curved jet curtain multiplied by the cross sectional area; therefore,

$$\frac{\dot{m}V(1+\cos\theta_i)}{g} = (P_B - P_C)\pi(r_i)^2,$$

For a close approximation, this equation reduces to

$$P_B = \frac{(\dot{t})}{r_o} \frac{\delta(V_o + V_i)^2}{2g} (1 + \cos\theta_i)$$

If it is desired that P_C will always be equal to zero, this may be accomplished by segmenting the annular exhaust jet at station A. This provides a vent between the inner and outer

surfaces of the exiting jet curtain and assures that the static pressure will be the same on both sides. The jet curtain will coalesce and by the time it reaches station C it will function as if there were no segmentation.

5 Energy, in the form of momentum must be added to the jet curtain between stations D and A. This may occur in many different forms, as one skilled in the art may choose their own preference. Several different methods will subsequently be described.

10 Referring to Figure 3B, the flow dynamics are exactly the same as we described for Figure 3A, with the exception that outside ambient fluid is being ingested by the reduced inlet pressure and by viscous entrainment. Dependent variables such as the amount of ambient fluid being ingested (ie., the mass
15 augmentation ratio) cannot be estimated precisely by analytical methods. However, empirical results, along with good design practice and built-in adjustment features in a prototype model will provide an optimized configuration for a given application.

20 The preferred embodiment of this invention is shown in figures 1 and 2 and can be described as an ejector powered recirculating oblate toroidal jet momentum pump. Each term of this description has meaning and will be explained in the following. With reference to figure 1, the preferred
25 embodiment is shown for a general purpose air/water pump. The choice of the words "air/water pump" mean precisely that - the

- 15 -

exact same physical pump can pump a gas such as air or pump a liquid such as water. This is a unique innovation in pump design, not known to exist in any other pump. The only modification required is an adjustment to the opening 37, in 5 Figure 1. Additionally, if the ambient fluid is a liquid such as water, it is not mandatory that the primary driving fluid also be of the same liquid. The primary driving fluid may be another liquid or even a gas, such as air.

As shown in figure 1, the primary driving fluid enters 10 through the inlet supply tube 40 to a plenum chamber 38. This plenum chamber is sized and shaped for particular applications. In some designs it may take the form of a donut shaped header. The essential design requirement here is to efficiently conduct the primary driving fluid from its' source to the primary 15 exhaust orifice 37. The internal cross sectional area, as viewed from the source of the primary power to the plenum must be greater than the annular throat area or there will be choking of the primary fluid upstream of the throat (for pressures greater than the critical pressure ratio of the 20 primary fluid). Losses such as those due to inlet design, velocity head, turbulence, heat, viscosity and exit design all need to be considered for particular applications. The primary driving fluid is discharged from primary exhaust orifice and by way of viscous entrainment and turbulent mixing, momentum 25 is added to the recirculating flow 44. In continuous steady state operational conditions, this added momentum replenishes

- 16 -

the expended energy in the recirculating curtain. This recirculating curtain normally contains more energy than the primary driving fluid which is only required to make up the deficit due to friction, turbulence, heat and other such losses.

Two questions require explanation at this juncture. One, there appears to be only one half of a conventional ejector shown in figure 1. Two, the recirculation flow field appears deceptively like a vortex. First, it has been surprisingly found through experimentation that for recirculating flow, an inner wall, which would be placed where a phantom void is illustrated and would form the missing side of a conventional annular ejector is not necessary. In some situations, it has been found that an inner wall improved the overall performance. However, the added complexity, cost and the possibility of clogging the recirculating flow inlet were offset by the simplicity and reliability shown in the preferred embodiment. Secondly, the recirculating flow field does possess a limited amount of similarity to free vortex flow, it does so only between stations C and D shown in figures 3A and 3B. Except for the suction embodiment shown in figure 9, nowhere else in the path of the recirculating flow is there any other similarity to vortex flow. This is imperative in understanding the mechanics involved in the operation of this invention.

- 17 -

With this understanding, the analysis of the flow field and the preliminary performance estimates may be derived from the teachings set forth in this disclosure.

In summary, the recirculating flow field of the preferred 5 embodiment of this invention is in the shape of a distorted torus, having the unique characteristics previously described between stations A, B, C and D. The preferred embodiment, therefore, consists of the following characteristics;

- a. ejector powered,
- 10 b. recirculating flow field,
- c. oblate toroidal in shape,
- d. curved jet of liquid or gas, which experiences a momentum change.

Figure 4 shows an additional embodiment. The apparatus 15 shown in figure 4 is identical to the apparatus shown in figures 1 and 2 except that it is constructed of a single piece and contains additional parts 46, 47 48, 49, 50, 51 and 52. It is apparent in figure 4 that there is no adjustable throat 36 as was shown in figures 1 and 2. A toroidal center-body 46 20 is included in this embodiment and forms the inner wall of the ejector and helps direct the recirculating flow around the turn and to the annular exhaust. The purpose of center-body 46 is to improve the efficiency by improving the turbulent mixing process of the ejector and to minimize the internal turning 25 losses. The underside of the center-body 46 is undercut at 47, containing a sharp lip 49 at the exit of the annular opening

28. In some configurations this has been found to be necessary in order to prevent the flow from attaching to the bottom of the center-body - this is called the Coanda effect. When this occurs, it totally disrupts the operation of the invention, however this will not occur with a properly designed center-body. An annular inlet plug 48 is included in this embodiment and is shaped and positioned so as to cause the radius of curvature of the recirculating flow to be decreased, thereby increasing the apparatus discharge static pressure.

10 It should be understood that the static pressure, or head that the pump will pump against is inversely proportional to the turning radius of the curved jet - all else being equal. A similar result to that of the inlet plug 48 occurs by the use of a centerline plug 50, which also reduces the value of the turning radius of the recirculating jet. The centerline plug 15 50 may have various sizes and shapes and be adjustable along the longitudinal centerline of the invention. The effect of centerline plug 50 is to cause the pump discharge pressure and flow rate to vary without changing any other of the independent 20 variables (such as the pressure/flow rate of the primary driving fluid.) Exit flaps 52 may be installed to redirect the angle of the exhausting jet flow in order to influence the performance of the invention. The center body 46, inlet plug 48 and centerline plug 50 may be incorporated separately or 25 jointly with the basic apparatus of this invention and may be adjustable or detachable.

- 19 -

The physical variables effecting the operation and performance are shown in figure 5. The significance of these variables - independent variables - is further shown in Table I. The combination of figure 5 and Table I is herein used to
5 expand on the relationship of these variables as they relate to various applications. Referring to figure 5 and Table I, the dimensions of these variables are given for the general purpose pump and by comparison, the relationship of these variables is shown for the other embodiments. These dimensions
10 may be scaled up or down as the application may require and other embodiments may have a completely different set of dimensions.

- 20 -

TABLE I								
INDEPENDENT VARIABLES								
FIG	CONFIGURATION	θ_o	θ_i	r	ri	ro	t	l
1-2	GENERAL PURPOSE	30	45	0.75	1	0.9	0.1	1.5
6	MASS FLOW (M)	LESS	MORE	MORE	MORE	MORE	EQUAL	EQUAL
7	PRESSURE (P)	EQUAL	LESS	EQUAL	LESS	LESS	EQUAL	EQUAL
8	THRUST (T)	EQUAL	LESS	EQUAL	LESS	EQUAL	LESS	EQUAL
9	SUCTION (S)	LESS	EQUAL	EQUAL	EQUAL	EQUAL	EQUAL	LESS
10	HEAT (Q)	EQUAL	LESS	EQUAL	LESS	LESS	EQUAL	EQUAL
11	ROBOTICS	EQUAL	LESS	EQUAL	LESS	LESS	EQUAL	EQUAL
12	FLUIDICS	EQUAL	EQUAL	M.LESS	M.LESS	M.LESS	M.LESS	M.LESS

NOTES:

1. Dimensions of θ_o and θ_i are in degrees.
2. Dimensions of r, ri, ro, t and l are in inches.
3. t is determined by the primary driving fluid used and the total pressure.

SUBSTITUTE SHEET

Tables I and II are organized to show a comparison of the relative design variables and consequential performance characteristics for other apparatuses which have been designed with emphasis on specific performance parameters. These parameters shown in Table II are referred to as dependent variables and each apparatus (which has been optimized for a specific performance characteristic) is compared to the general purpose apparatus.

TABLE II DEPENDENT VARIABLES						
FIG	RAMIFICATION	M	P	T	S	Q
1-2	GENERAL PURPOSE	MED	MED	MED	MED	MED
6	MASS FLOW (M)	HIGH	LOW	LOW	LOW	LOW
7	PRESSURE (P)	LOW	HIGH	MED	LOW	LOW
8	THRUST (T)	HIGH	HIGH	HIGH	MED	HIGH
9	SUCTION (S)	MED	MED	LOW	HIGH	NA
10	HEAT (Q)	HIGH	LOW	LOW	LOW	HIGH
11	ROBOTICS	LOW	MED	VARIES	LOW	NA
12	FLUIDICS	V.LOW	MED	LOW	MED	NA

- 22 -

TABLE III
SYMBOLS & ABBREVIATIONS

θ_o	Angle of discharge of recirculating jet at station A, ref. longitudinal centerline, degrees
θ_i	Angle of intake of recirculating jet at station D, ref. longitudinal centerline, degrees
δ	Density of the media, lb/cu.ft.
π	Pi
l	Length of mixing section of recirculating ejector, inches
m	Mass flow of recirculating jet between stations C and D, lbs/cubic ft
r	Turning radius of recirculating ejector jet, inches
r_i	Radius of opening of apparatus at the entrance end, inches
r_o	Radius of opening of apparatus at the exit end, inches
r	Average turning radius of the curved jet between stations C and D, inches
t	Adjustable throat of apparatus, inches
$\frac{t}{r}$	Average thickness of curved jet between stations C and D, inches
M	Apparatus optimized for maximum MASS FLOW
P	Apparatus optimized for maximum PRESSURE
P_a	Ambient pressure, lb/sq in
P_b	Discharge static pressure, lb/sq in
P_c	Cavity pressure sensed by the inside streamlines of the curved jet between stations C & D
Q	Apparatus optimized for maximum HEAT TRANSFER
S	Apparatus optimized for maximum SUCTION
T	Apparatus optimized for maximum THRUST
$\frac{V}{r}$	Average velocity of curved jet between stations C & D, ft/sec
V_i	Velocity of the media at station D, ft/sec
V_o	Velocity of the media at station A, ft/sec

SUBSTITUTE SHEET

- 23 -

For optimum mass flow (M), refer to figure 6. If the objective is to induce the maximum possible through-flow, then this invention has application in such areas as: ventilation, cooling, heating, drying, and dehumidifying, and with the injector nozzle 56, further applications include spraying fluids such as insecticides, fertilizer, paints, protective coatings, cleaning solutions, blowing foam for insulation and artificial snow.

Figure 6A is a schematic illustration showing how multiple stages of the concept may be arranged to obtain even higher mass flow through the apparatus.

For optimum static pressure (P) increase, refer to Figure 7. If the objective is to increase the static pressure of the tertiary flow as much as possible, then the invention has application in such areas as: well/sump pump; pipeline booster pump; dewatering at construction sites; pumping fluidized solids; conveying grain; aeration/agitation and blending of slurries, liquids and gases; pumping sewage; conveying sawdust, chips, cement, pulverized coal and ash; as an agriculture pump, trash pump; pumping underground fluids to the surface such as oil, water and sulfur and with the injection nozzle as a sand blasting device.

Figure 7A is a schematic illustration showing how multiple stages of concept may be arranged to obtain even higher static pressures.

- 24 -

For optimum thrust (T), refer to figure 8. If the objective is to maximize the momentum imparted to the tertiary flow, the invention has application in such areas as: jet propulsion engine for operation in the air (atmosphere) or underwater, 5 (either with or without internal combustion) as marine maneuvering side thrusters, tip jets to power the rotor of a helicopter and first stage boosters for rockets and missiles. The apparatus, as shown in figure 8, indicates that the critical pressure ratio of the media has been exceeded and the 10 exhausting Gas is traveling at a speed greater than sonic velocity from the supersonic nozzle 80. Fuel is introduced through an injector nozzle 60 and flame holders are located in the combustion chamber 76. Various type of fuels may be used, with or without an oxidizer, including liquid monopropellants.

15 Figure 8A illustrates schematically how the invention may be integrated into the body of missile which may be operated in the atmosphere or under water. Other embodiments may include "strap on" configurations for such as first stage boosters.

20 For optimum suction (S), refer to figure 9. If the objective is to obtain the lowest (negative) static pressure at the inlet of the device, then the invention has application in such areas as: the suction head for cleaning an oil spill, dredging from the sea floor, sea harvesting, snow removal, 25 street/plant floor vacuum, harvesting grove/orchard produce, aquaculture (esp. conveying live creatures), brush fire

- 25 -

fighting by inundating the brush with dirt/soil, and for exhaust gas scavenging for internal combustion engines.

Notice in figure 9 that the curvature of the recirculating jet Heat the apparatus entrance 24 has negative curvature 62. Even though the total pressure gradient between the entrance and exit of this configuration is approximately the same as that for the general purpose configuration, the apparatus of figure 9 is capable of generating relatively high values of suction at the entrance. This is a result of the
10 aforementioned negative curvature of the jet.

For optimum heat transfer (Q), refer to figure 10. If the objective is to optimize heat obtainable (as measured in BTU/hr), then the invention has application in such areas as: a furnace or boiler burner, grove and orchard heater and fog
15 dispersal at airports.

This apparatus, which is shown in figure 10, has several features which can also be incorporated in previous apparatuses referred to above. These features are:

- a. A secondary stage, as shown by the secondary
20 supply tube 64, secondary plenum 66 and secondary annular opening 68. This secondary stage may contain the same media as the primary, or it may consist of a gaseous fuel;
 - b. Fuel injectors 70;
 - c. Combustion chamber 76;
 - d. Flame holders 74;
 - e. Igniter, spark plug or glow plug 72; and
- 25

- 26 -

f. Nozzle 78.

For a robotic apparatus which provides a constant force, regardless of position or angle, refer to figure 11. A recirculating ejector 82, a cylinder 84, a piston 86 and a rod 5 88 are illustrated. This embodiment creates and sustains a pressure P_b confined by the recirculating jet curtain, the walls of the cylinder 84 and the head of the piston 86. The pressure P_b remains constant, since it is a function of the primary driving fluid pressure, therefore, the pressure force 10 on the piston and the reactive force against the rod is also constant. This will be true regardless of the position of the piston (and rod) or angular orientation of the apparatus.

For a fluidic apparatus which provides free flow, or amplified flow in one direction but greatly restricts the flow 15 in the opposite direction, refer to figure 12. A recirculating ejector 82, an inlet tube 90 and an exhaust tube 92 are illustrated. When the apparatus is operating, a positive pressure is created and sustained downstream and a negative gage pressure is created and sustained upstream. Pressure 20 gages are shown schematically at upstream and downstream positions and show a positive pressure gradient in a downstream direction.

Having thus described a preferred embodiment of the invention, it will be understood that this invention may be in 25 other forms than that described as being the preferred embodiment and without departing from the scope of the

- 27 -

invention as defined by the appended claims. Additionally,
while the best mode for carrying out this invention has been
described in detail, those familiar with the art to which this
invention relates will recognize various alternative designs
5 and embodiments for carrying out this invention as defined by
the following claims.

PART NUMBERS

#	DESCRIPTION
20	THE APPARATUS
22	CONDUIT
24	ENTRANCE END
26	EXIT END
28	FIRST ANNULAR RING (EXIT)
30	SECOND ANNULAR RING (ENTRANCE)
32	OUTER SHELL
34	INNER SHELL
36	ADJUSTABLE THROAT
38	PLENUM
40	INLET SUPPLY TUBE
42	THROAT DIMENSION
44	RECIRCULATING FLOW
46	TOROIDAL CENTER-BODY
48	ANNULAR INLET PLUG
50	CENTERLINE PLUG
52	EXIT FLAPS
54	VOID (TOROIDAL CENTER-BODY REMOVED)
56	INJECTOR OR EJECTOR
58	INJECTOR, ANNULAR
60	INJECTOR, FUEL
62	NEGATIVE CURVATURE (SUCTION)
64	SECONDARY SUPPLY TUBE
66	SECONDARY PLENUM
68	SECONDARY THROAT
70	FUEL INJECTORS
72	SPARK PLUG OR GLOW PLUG
74	FLAME HOLDERS
76	COMBUSTION CHAMBER
78	NOZZLE
80	SUPERSONIC NOZZLE
82	RECIRCULATING EJECTOR EMBODIMENT, SCHEMATIC
84	CYLINDER
86	PISTON
88	ROD
90	INTAKE TUBE
92	EXHAUST TUBE

THAT WHICH IS CLAIMED IS:

1. A pumping apparatus comprising:
conduit means having an entrance and exit
two annular openings axially symmetrical about a
5 centerline of said conduit means said annular openings being
linearly displaced in relationship to said centerline, one of
said annular openings nearer said entrance being an exhaust for
fluid media, and, the other said annular opening being intake
for said fluid media;
- 10 2. The apparatus according to claim 1 wherein said conduit
means comprises;
an outer shell;
an inner shell connected to said outer shell and
defining said entrance;
15 a throat attached to said outer shell and defining on
one end thereof said exit and on the other end thereof said
other annular opening.
- 20 3. The apparatus according to claim 2 wherein said end of
said throat defining said other annular opening is spaced from
said outer shell to define a primary exhaust orifice of
thickness t ;
said outer shell defining between said inner shell and
said throat a plenum for forcing a driving fluid through said
primary exhaust orifice.
- 25 4. The apparatus according to claim 3 including a supply
tube in communication with said plenum.

5. A process for comprising the steps of:

providing,

conduit means having an entrance and an exit
and having therein two annular axially symmetrical
openings about a centerline of said conduit means,
said annular openings being linearly displaced in
relationship to said centerline,

one of said annular openings near said
entrance being an exhaust for a fluid media, and

the other said annular opening being an
intake for said fluid media;

forcing a primary fluid medium from said exhaust;

causing said primary fluid medium to enter said intake
to effect a change of momentum causing the drawing in of a
secondary fluid into said entrance and forcing said fluid
toward said exit.

AMENDED CLAIMS

[received by the International Bureau on 22 April 1992 (22.04.92);
original claims 1-5 replaced by amended claims 1-3 (3 pages)]

1. A pumping apparatus comprising:

a conduit having an entrance for a pumped fluid and an exit for said pumped fluid;

5 said conduit being formed by an outer shell and an inner shell connected to said outer shell, said inner shell defining said entrance;

two annular surfaces symmetrical about a centerline of said conduit, said annular surfaces being linearly displaced
10 in relationship to said centerline, one of said annular surfaces nearer said entrance forming an exhaust for a primary fluid, and the other said annular surface being an intake for said primary fluid;

a throat attached to said outer shell forming a portion
15 of said conduit and defining on one end thereof said exit and on the other end thereof said other annular surface;

said end of said throat defining said other annular surface being spaced from said inner shell to define a primary exhaust orifice of thickness "t";

20 said outer shell defining between said inner shell and said throat a plenum for said primary fluid so that said primary fluid can be forced through said primary exhaust orifice;

said throat curving radially outwardly opposite the
25 direction of pumped fluid flow;

said inner shell having an interior surface having a radially outward curvature followed by a radially inward curvature followed by a curvature in the axial direction of pumped fluid and forming said one annular surface at its
5 termination whereby exhausting of said primary fluid at said one annular surface and intaking of said primary fluid at said other annular surface cause said pumped fluid to move from said entrance toward said exit.

2. The apparatus according to claim 1 further including
10 a supply tube in communication with said plenum.

3. A process for pumping a fluid media comprising steps of:

a conduit having an entrance for a pumped fluid and an exit for said pumped fluid; said conduit being formed by an
15 outer shell and

an inner shell connected to said outer shell, said inner shell defining said entrance;

two annular surfaces symmetrically about a center line of said conduit, said annular surfaces being linearly displaced
20 in relationship to said center line, one of said annular surfaces nearer said entrance forming an exhaust for a primary fluid, and the other said annular surface being an intake for said primary fluid;

a throat attached to said outer shell forming a portion
25 of said conduit and defining on one end thereof said exit and on the other end thereof said other annular surface;

said end of said throat dehinging said other annular surface being spaced from said inner shell to define a primary exhaust orifice of thickness "t";

said outer shell defining between said inner shell and
5 said throat a plenum for said primary fluid so that said primary fluid can be forced through said primary exhaust orifice;

said throat curving radially outwardly opposite the direction of pumped fluid flow;

10 said inner shell having an interior surface having a radially outward curvature followed by a curvature in the axial direction of pumped fluid and forming said one annular surface at its termination;

forcing a primary fluid medium from said primary
15 exhaust orifice, said primary fluid medium passing over said one annular surface to affect a change of momentum of said primary fluid thereby causing the drawing in of a said pumped fluid into said entrance and forcing said pumped fluid toward exit.

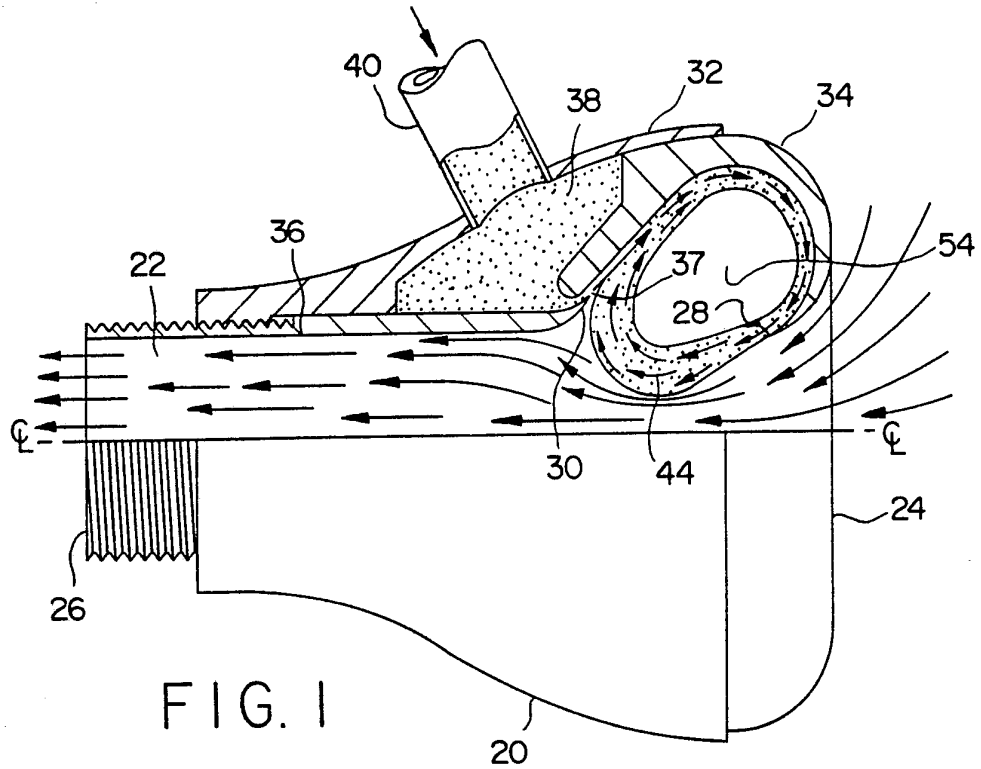

FIG. 1

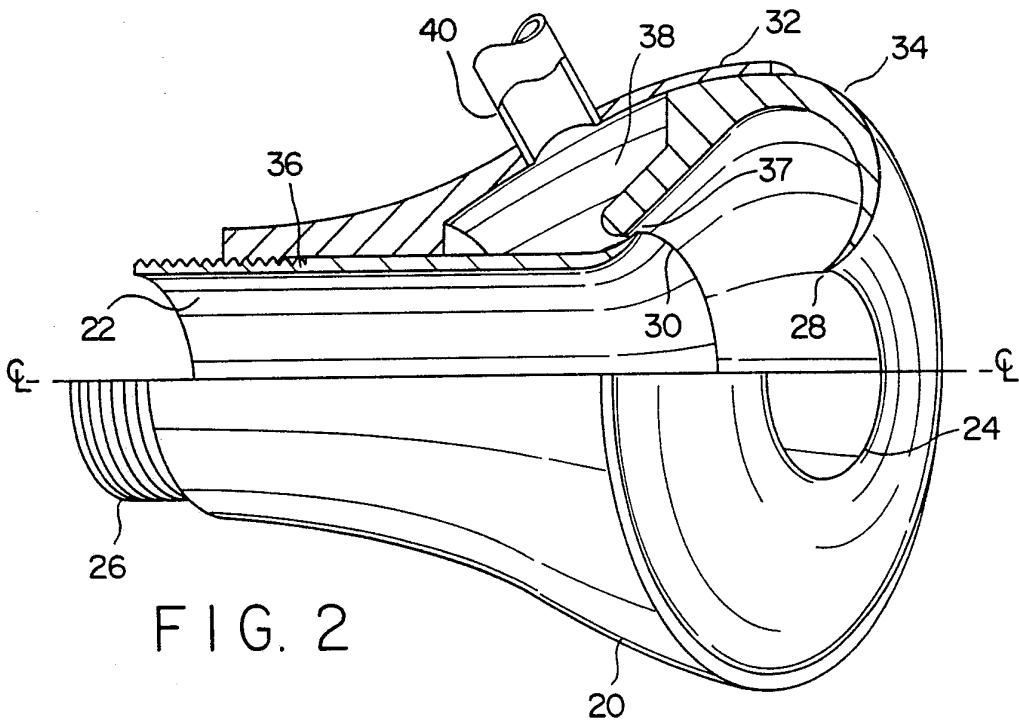

FIG. 2

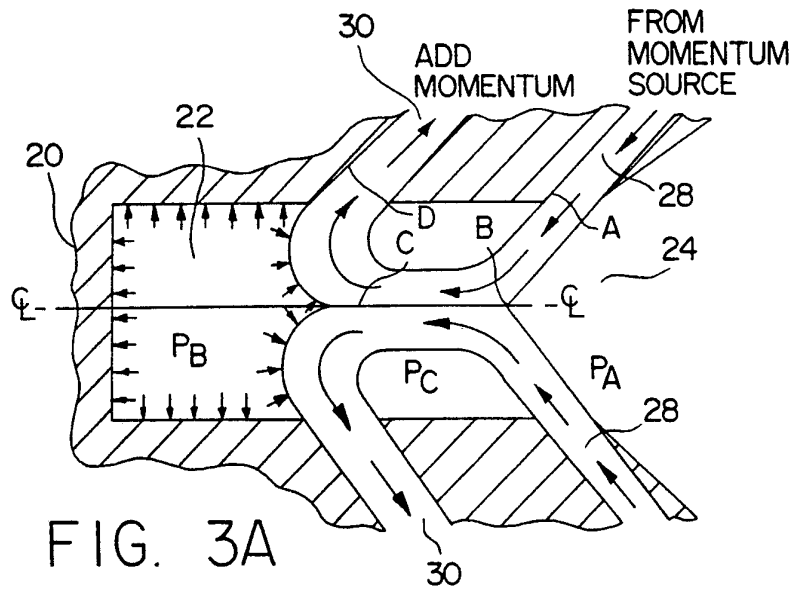

FIG. 3A

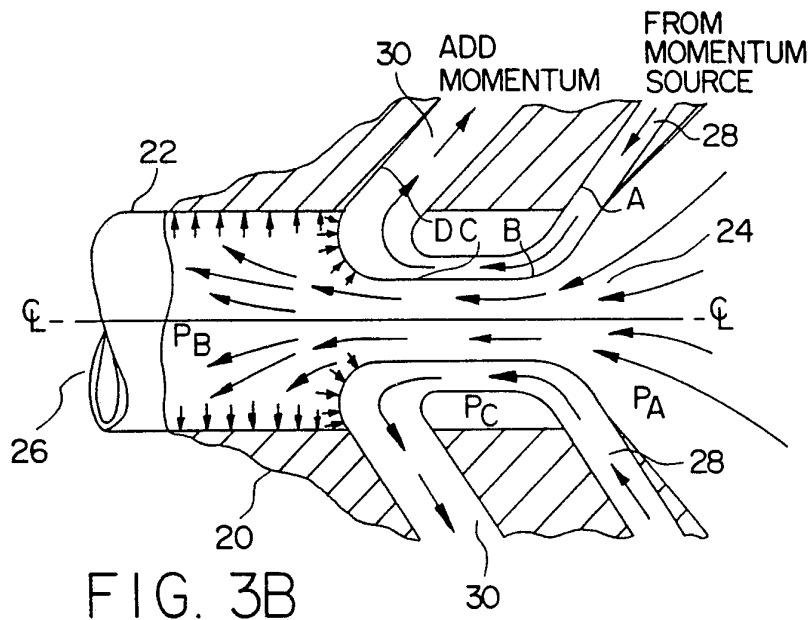

FIG. 3B

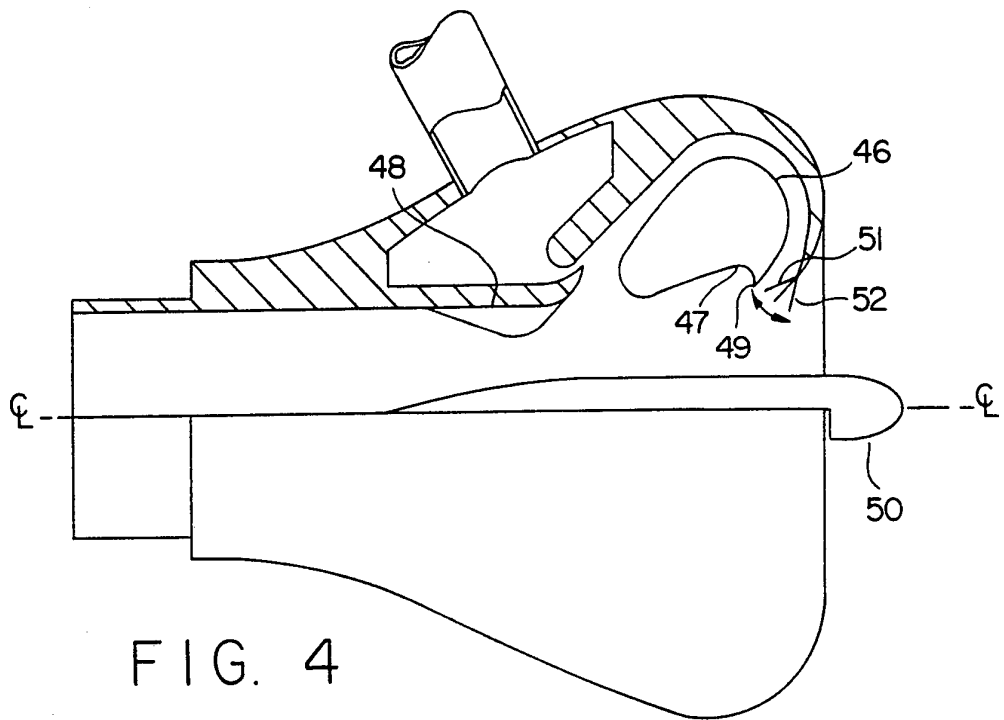

FIG. 4

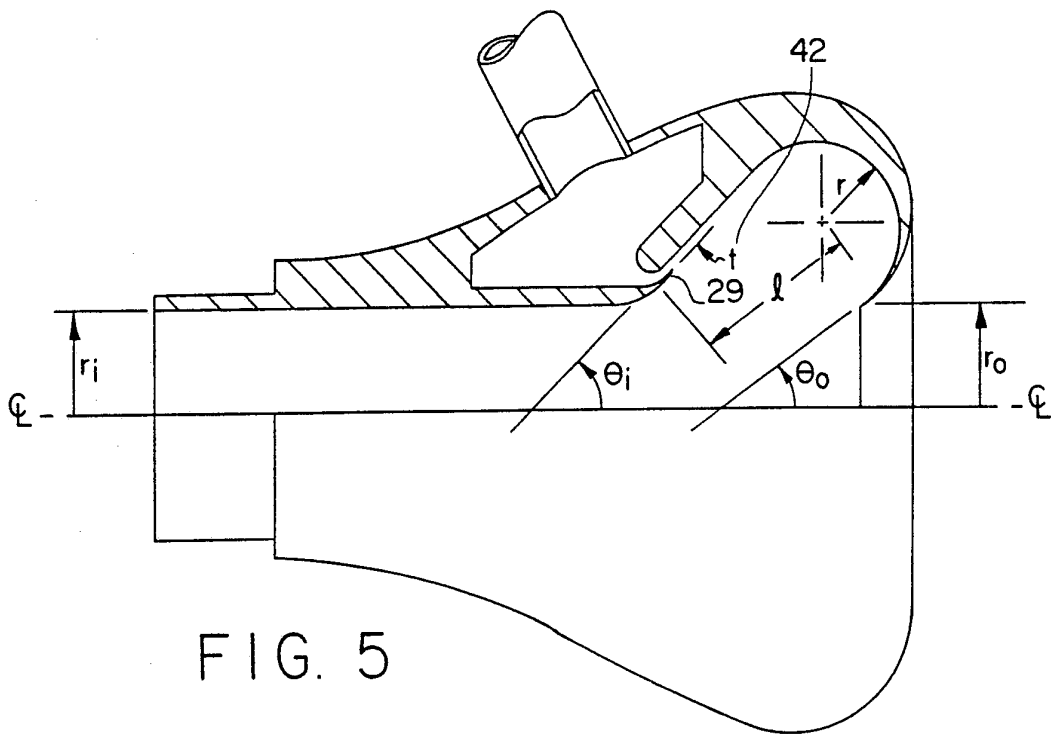

FIG. 5

4 / 7

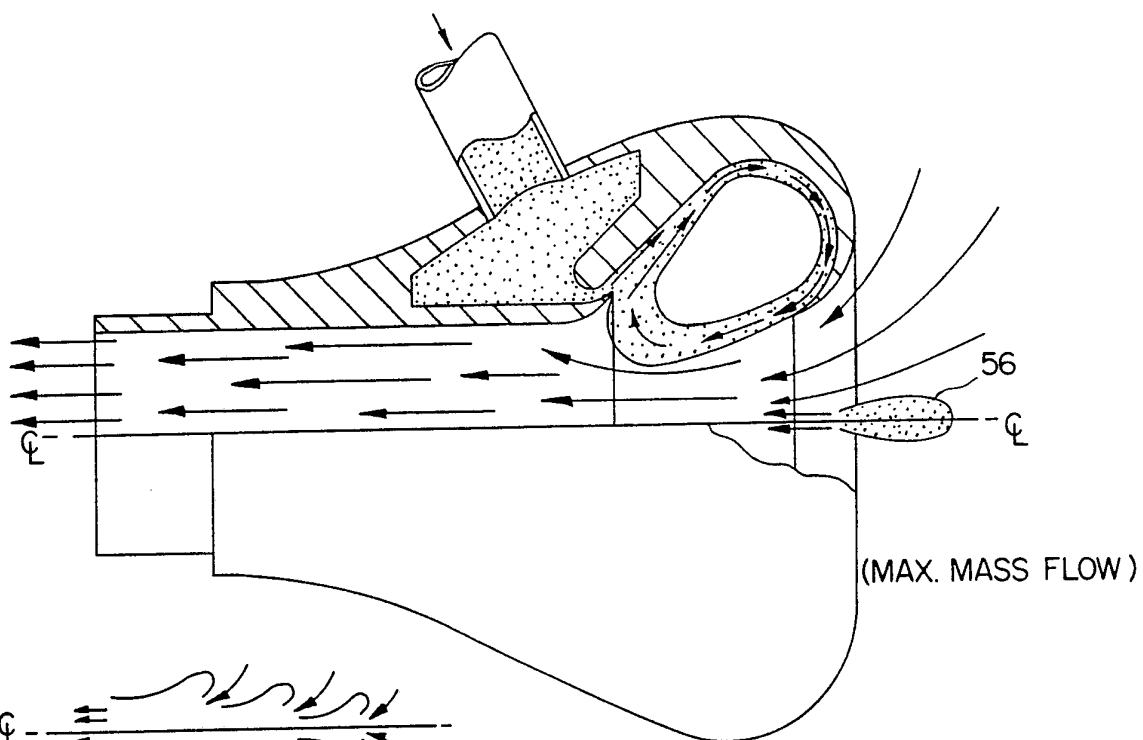

FIG. 6A

FIG. 6

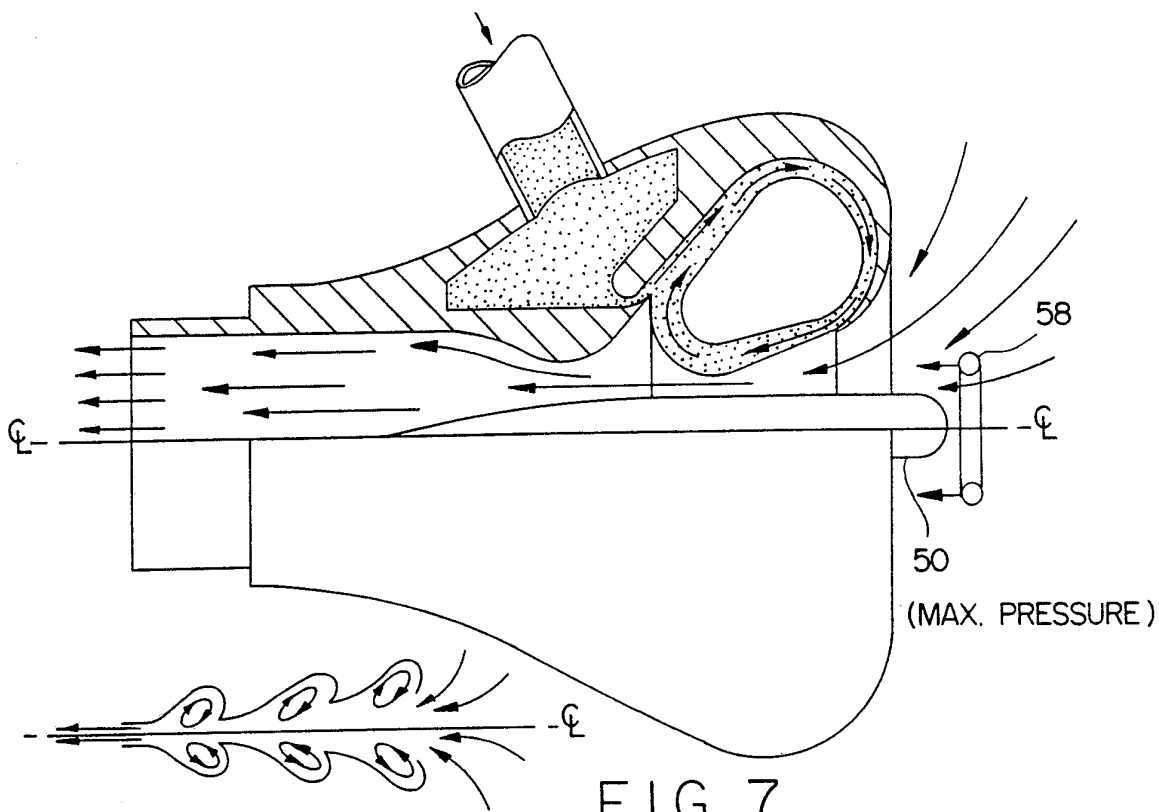

FIG. 7A

FIG. 7

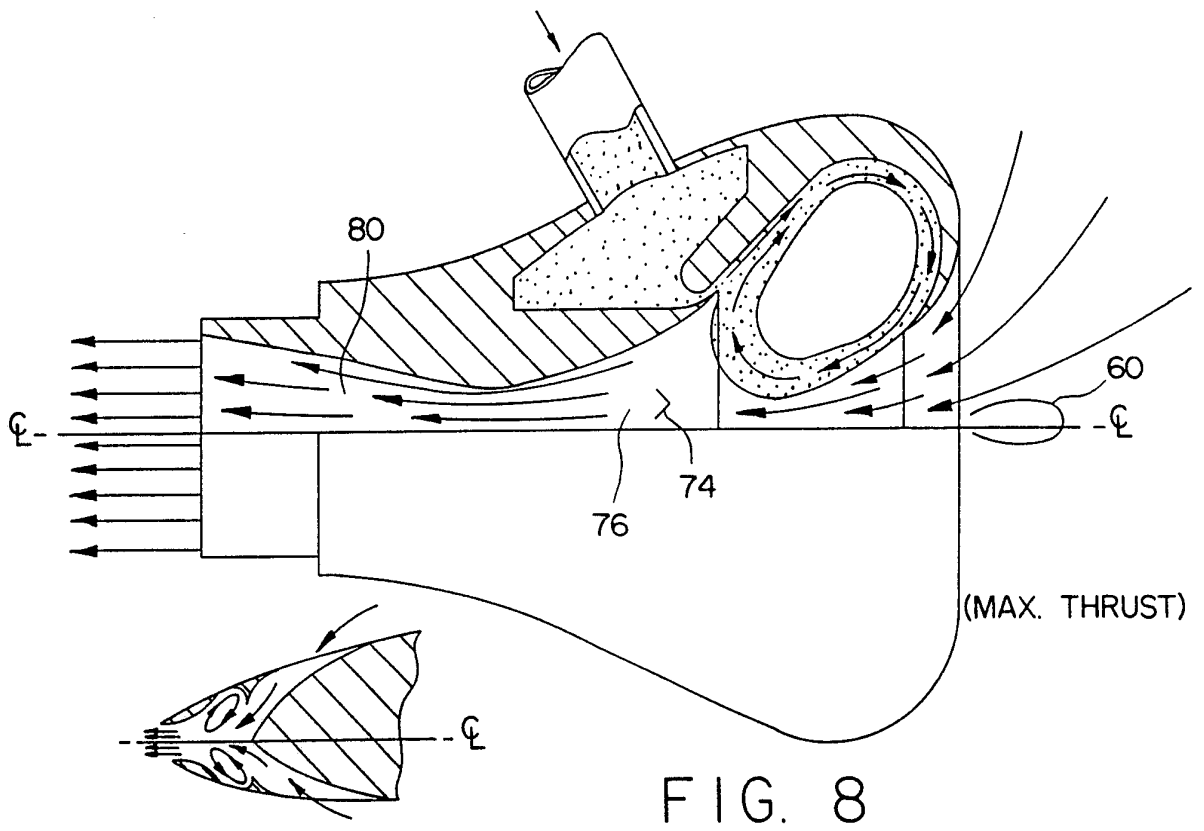
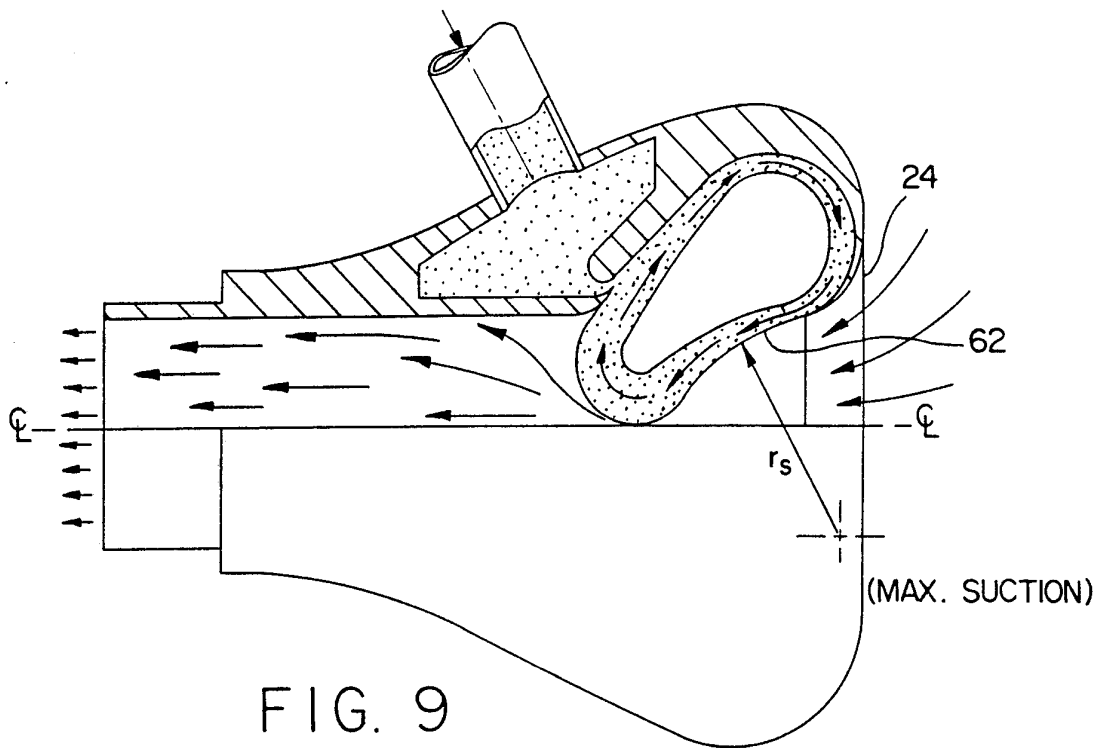

FIG. 8A



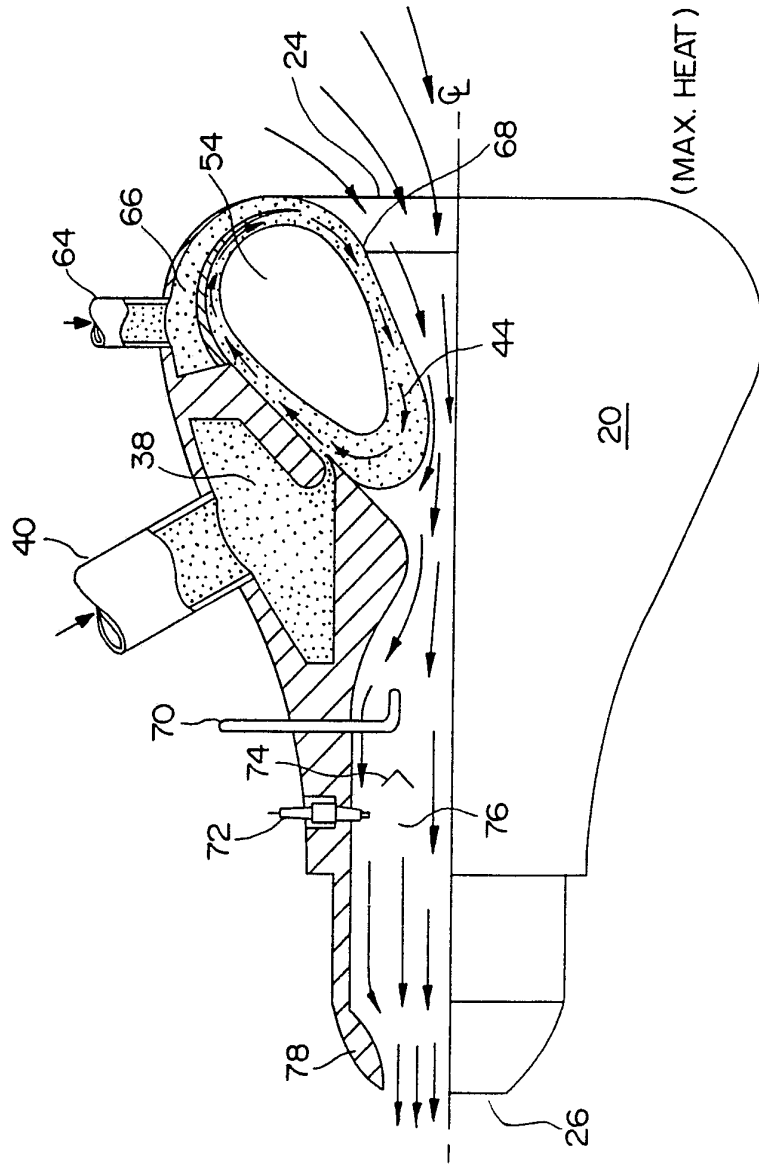

FIG. 10

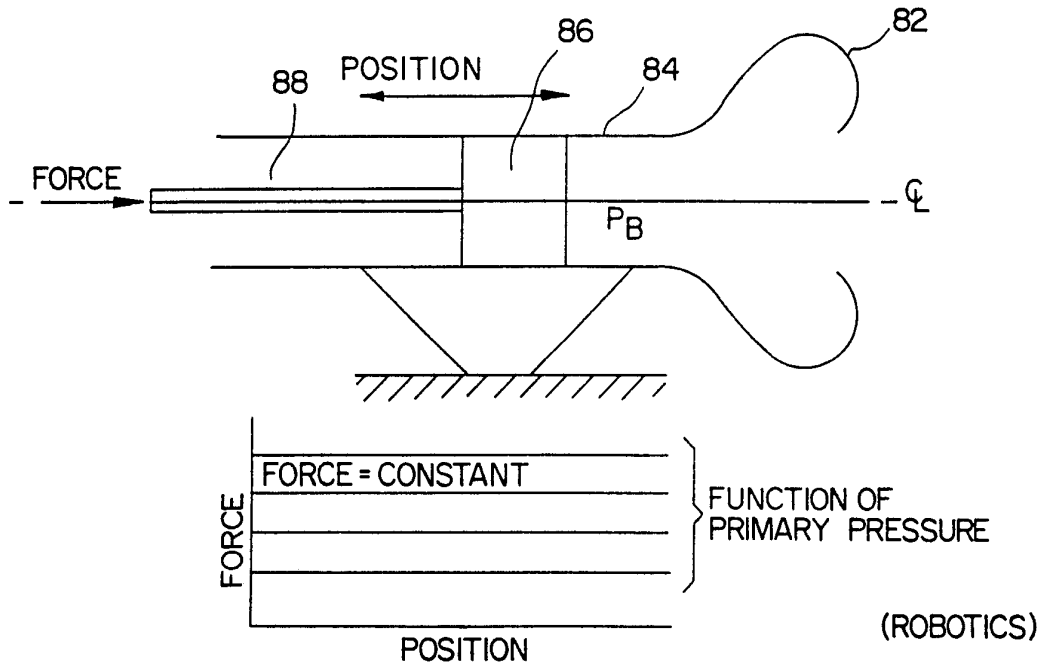

FIG. 11

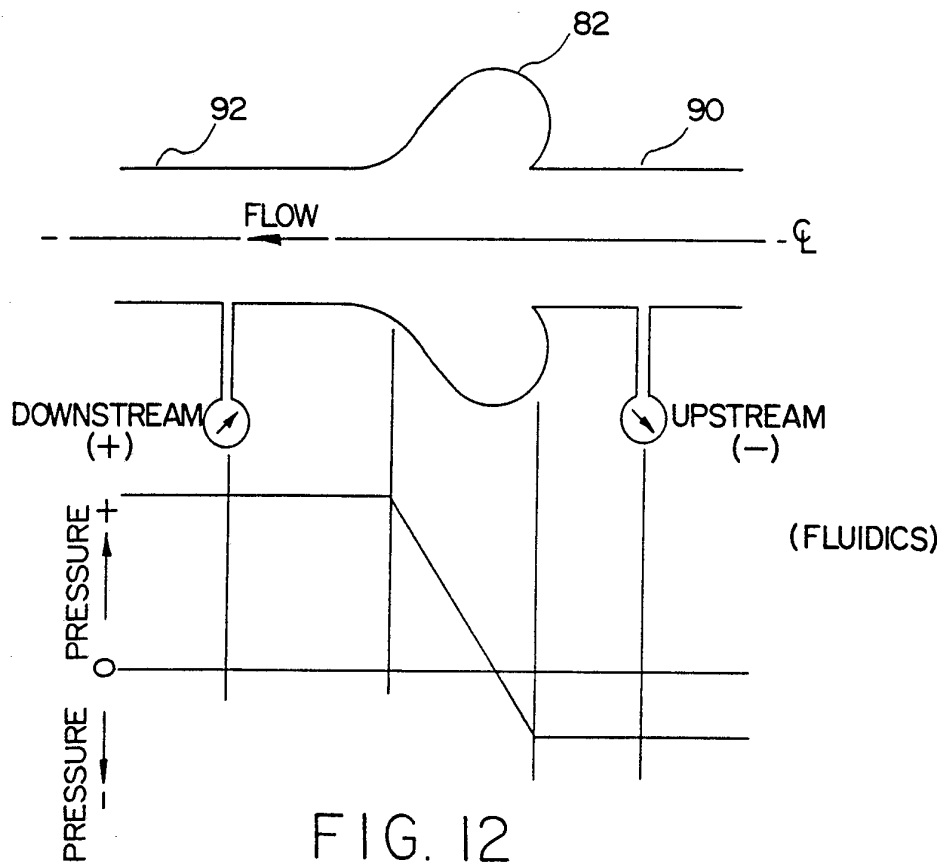

FIG. 12

INTERNATIONAL SEARCH REPORT

International Application No. PCT/US91/08839

I. CLASSIFICATION OF SUBJECT MATTER (if several classification symbols apply, indicate all) ⁶		
According to International Patent Classification (IPC) or to both National Classification and IPC		
IPC(5): F04F 05/44		
US Cl: 417/198,163,171,183,197		
II. FIELDS SEARCHED		
Minimum Documentation Searched ⁷		
Classification System	Classification Symbols	
	417/198,163,171,183,197,170,151,182	
US	137/888,896	
Documentation Searched other than Minimum Documentation to the Extent that such Documents are Included in the Fields Searched ⁸		
III. DOCUMENTS CONSIDERED TO BE RELEVANT ⁹		
Category [*]	Citation of Document, ¹¹ with indication, where appropriate, of the relevant passages ¹²	Relevant to Claim No. ¹³
X	US,A, 2,444,615 (Reinhardt) 06 July 1948, see entire document	1-5
X	US,A, 2,293,115, (Child) 18 August 1942, See entire document	1
A	US, A, 4,046,492 (Inglis) 06 September 1977, see figures 2-4 and column 3, line 63 - column 5, line 2.	1-5
A	US,A, 4,192,461 (Arborg) 11 March 1980, see figure 5.	1-5
<p>[*] Special categories of cited documents: ¹⁰</p> <p>"A" document defining the general state of the art which is not considered to be of particular relevance</p> <p>"E" earlier document but published on or after the international filing date</p> <p>"L" document which may throw doubts on priority claim(s) or which is cited to establish the publication date of another citation or other special reason (as specified)</p> <p>"O" document referring to an oral disclosure, use, exhibition or other means</p> <p>"P" document published prior to the international filing date but later than the priority date claimed</p> <p>"T" later document published after the international filing date or priority date and not in conflict with the application but cited to understand the principle or theory underlying the invention</p> <p>"X" document of particular relevance; the claimed invention cannot be considered novel or cannot be considered to involve an inventive step</p> <p>"Y" document of particular relevance; the claimed invention cannot be considered to involve an inventive step when the document is combined with one or more other such documents, such combination being obvious to a person skilled in the art.</p> <p>"&" document member of the same patent family</p>		
IV. CERTIFICATION		
Date of the Actual Completion of the International Search	Date of Mailing of this International Search Report	
24 January 1992	21 FEB 1992	
International Searching Authority	Signature of Authorized Officer	