

(No Model.)

2 Sheets—Sheet 1.

W. WHITE.  
WOOL DRIER.

No. 523,875.

Patented July 31, 1894.

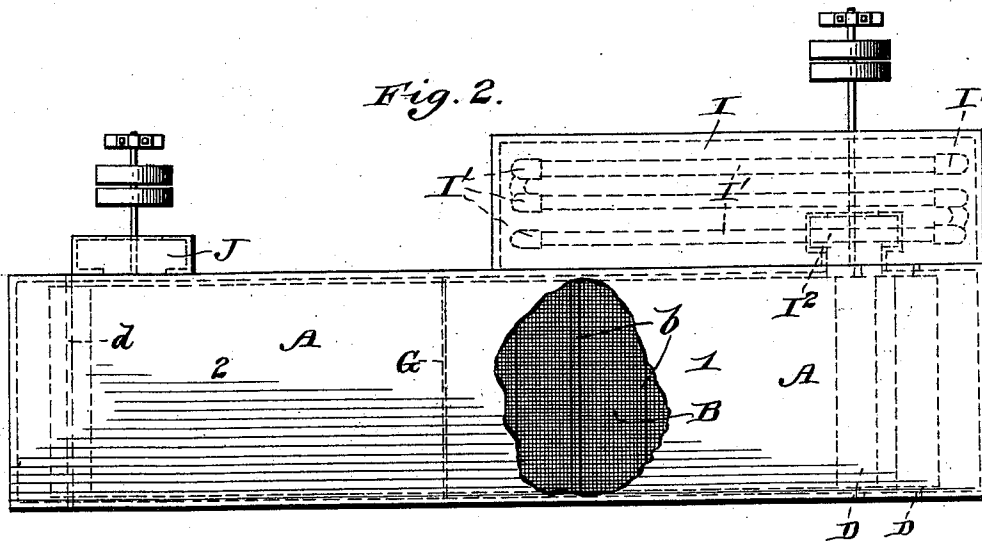
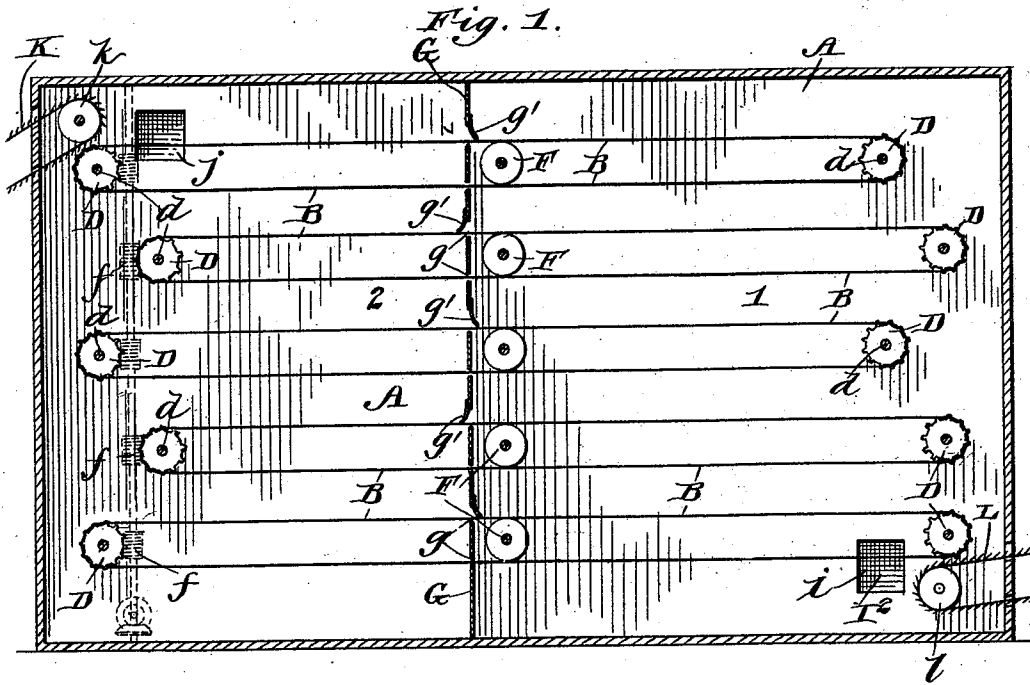

Witnesses

*Everance*  
*W. Harry Muzzy*

Inventor  
*William White*  
by  
*Maxon Fenwick Lumsden*  
his Attorneys

(No Model.)

2 Sheets—Sheet 2.

W. WHITE.  
WOOL DRIER.

No. 523,875.

Patented July 31, 1894.

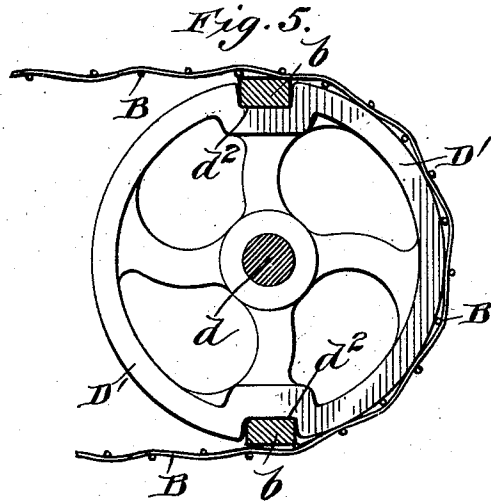
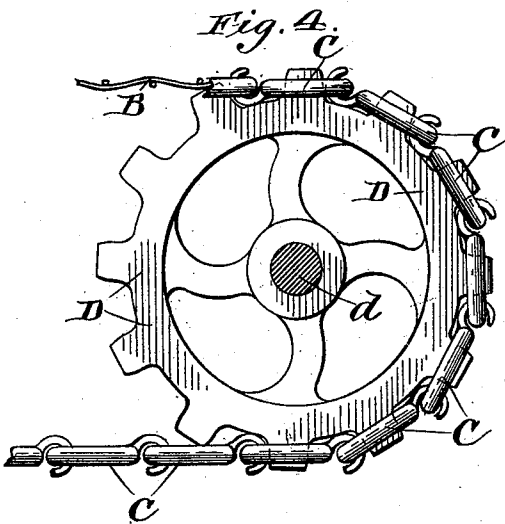
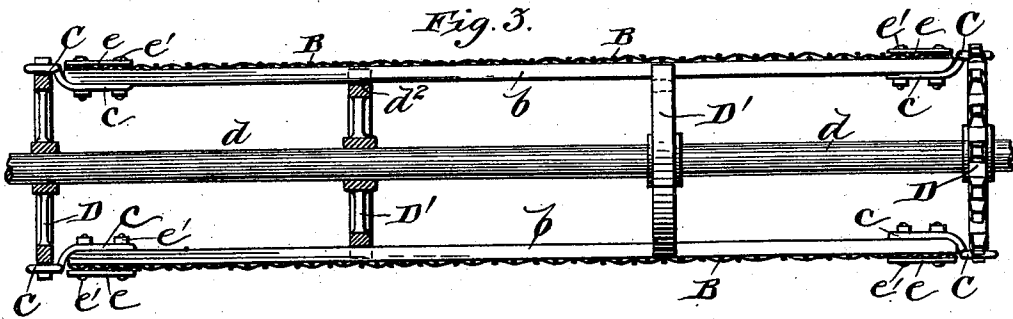
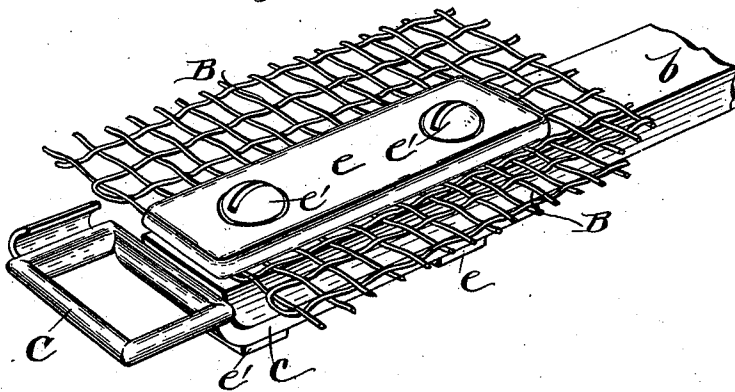

Fig. 6.



Witnesses

*Geverance.*  
*W. Harry Muzzey.*

Inventor  
*William White*  
by  
*Maxim Smith Lawrence.*  
Attorneys

# UNITED STATES PATENT OFFICE.

WILLIAM WHITE, OF NASHUA, NEW HAMPSHIRE.

## WOOL-DRIER.

SPECIFICATION forming part of Letters Patent No. 523,875, dated July 31, 1894.

Application filed March 8, 1894. Serial No. 502,905. (No model.)

*To all whom it may concern:*

Be it known that I, WILLIAM WHITE, a citizen of the United States, residing at Nashua, in the county of Hillsborough and State of New Hampshire, have invented certain new and useful Improvements in Wool-Driers; and I do hereby declare the following to be a full, clear, and exact description of the invention, such as will enable others skilled in the art to which it appertains to make and use the same.

My invention relates to improvements in drying machines and has more especially to do with apparatus for drying wool and the invention consists in certain novel construction, combinations and arrangement of parts as will be hereinafter described and claimed.

The invention is set forth in the following specification and illustrated in the accompanying drawings, in which latter—

Figure 1. represents a central vertical section of the devices embodying my invention. Fig. 2. represents a top plan view of the same, the outer casing being partially broken away to expose the wire belt or apron within. Fig. 3. represents a central vertical section through the shaft and pulleys which support and operate one of the endless wire belts. Fig. 4. represents a detail side elevation of one of the sprocket wheels which operate the sprocket chains carrying the endless wire belts. Fig. 5. represents a side elevation of one of the wire belt supporting wheels showing its notched periphery for receiving the supporting bars of the wire belt, and Fig. 6. represents a detail perspective view of one of the chain links, a portion of the wire belt and the belt supporting bar attached to said link.

A in the drawings represents the casing of the drying chamber which contains the endless traveling wire aprons B which convey the wet or damp wool back and forth through said drying chamber and thereby repeatedly bring said wool in contact with the hot air in said drying chamber whereby it is thoroughly dried.

The wire belts or aprons B are each composed of an endless open work wire belt which is supported on cross bars *b* having their ends attached to brackets *c* of the links C which form part of the sprocket chains on each side

of the aprons. These sprocket chains are endless and pass over sprocket wheels D mounted on shafts *d* in each end of the drying chamber. The chains are composed of links similar to C and others similar in all respects except that the brackets *c* are omitted. The links C are placed about every twelve inches in the chain as it is only necessary to have the cross supporting bars *b* at that distance apart. The ends of the cross bars *b* are placed on the brackets *c* of the links C, and the belt B and said bracket and cross bar are all secured together by attaching plate *e* and securing bolts *e'*. It will thus be seen that the wire belts are supported every twelve inches by the cross bars *b* and thus kept from sagging, and the belt when it reaches the sprocket wheels may bend and pass about them on their pitch line as the peculiar formation of the bracket *c* with its step connection with the link C, so support the belts that they are flush with the tops of the links and are thus capable of this action. The shafts *d* also carry wheels D' which are provided with notches *d<sup>2</sup>* into which the bars *b* fit as the wire belts pass about said wheels. These wheels are intended to support the center of the belt as it makes the turn and to keep it from twisting in making said turn. The shafts *d* at the forward end of the machine are each provided with a gear wheel which is engaged and operated by a worm *f* on a vertical powershaft. The center of the sprocket chains are supported on each side by wheels or rollers F upon which they rest.

A partition G divides the drying chamber into two compartments 1 and 2 and is provided with horizontal apertures *g* through which the endless aprons pass. The apertures are closed by flexible strips or aprons *g'* which rest lightly on the aprons B and thus keep the heat from passing too freely from one chamber to the other but at the same time allow the wool on said aprons B to readily pass them.

The heating device as shown in Fig. 2 consists of an auxiliary chamber I placed beside the main chamber A and provided with a steam heating coil I' and a blower I<sup>2</sup> by which the heated air in said chamber I is forced through an aperture *i* into the main chamber. The moisture laden air is drawn from the

main chamber through an aperture *j* by a suction blower *J*. Both of the blowers are operated from the main source of power.

The belts *B* are so placed that the wool falling from one belt will be caught on the end of the belt immediately beneath it.

The wool is fed into the chamber and onto the top belt by a spur belt *K* which passes about a belt wheel *k*. It is then carried the length of the said chamber and dropped upon the next belt and so on until it reaches the bottom belt from which it is dropped onto a discharge spur belt *L* similar to the belt *K* and supported by a belt wheel *l*; said discharging belt conveying the dried wool from the chamber and to any convenient receptacle outside of the same.

It will be seen from the foregoing that when the heated air is forced into compartment 1 of the chamber *A*, it cannot pass the partition *G* into the compartment 2 until a sufficient pressure is reached, when the air will force its way beneath the flexible flaps and be drawn out through the suction opening *j*.

The peculiar formation of the open work wire aprons permits the heated air to pass freely through said aprons and the wool carried thereby and said heated air thus takes up or absorbs the moisture in said wool and carries it from the chamber, the partition *G* preventing the air from escaping until it is fully laden with moisture at which time it is allowed to freely pass out.

The belts or aprons are so operated that every other one travels in an opposite direction and thereby the wool is carried back and forth from end to end of the chamber.

By my invention the wool is thoroughly dried after it has passed through the drying chamber as the partition that divides said chamber keeps the hot air in actual contact with said wool all the time and the peculiar formation of the wire belts permits the hot air to pass through the wool as well as over and under it.

It will be observed that the supporting wheels *D'* are so placed on the axle between the sprocket wheels as to keep the wire belt from sagging in the middle and keep it well up to the pitch line of the sprocket wheels. The brackets which support the wire belt supporting bars are so placed it will be noted that the belt is caused to travel on the pitch line of the sprocket wheels. If the belt did not travel on the pitch line of the sprocket wheels it would travel either faster or slower according to whether it was below or above the pitch line and therefore the supporting wheels which are on the pitch line of the sprocket wheels, could not be used.

What I claim as my invention is—

1. In a drying apparatus, the combination of an inclosing chamber having two commu-

nicating compartments, a partition between said compartments provided with slits or apertures, flexible flaps covering said apertures, a series of endless reticulated conveying aprons provided with supporting bars on their under sides and operating in said compartments in opposite directions and passing through said slits or apertures beneath the said flexible flaps, shafts carrying sprocket wheels for operating said aprons, supporting wheels carried by said shafts and provided with notches for receiving the supporting bars of the aprons so as to allow said aprons to rest directly upon the peripheries of said wheels, a heating device discharging into one compartment and a suction blower located in the other compartment for drawing the air from the same; the air in the first compartment being kept under pressure and compelled by the flexible flaps to come in contact with the contents of the aprons and means for operating the aprons, substantially as described.

2. In a drying apparatus, the combination with a casing of an endless, reticulated, movable drying apron provided on its under side with supporting cross bars, a sprocket link attached to each end of each bar, outside the apron, sprocket chains connecting said links, shafts carrying sprocket wheels adapted to receive and actuate said chains, apron supporting wheels mounted on said shafts and provided with notches which are adapted to receive said supporting bars and thereby permit the apron to rest directly upon the peripheries of said supporting wheels and means for operating the apron, substantially as described.

3. In a drying apparatus, the combination with an inclosing casing of an endless reticulated, movable drying apron provided on its under side with supporting bars, operating sprocket chains, the connecting links of which, at the ends of the bars are provided with depressed attaching brackets in which the ends of the bars are seated and secured so that the upper surface of the apron will be on the pitch line of the sprocket wheels, a shaft carrying sprocket wheels adapted to receive and actuate said chains, apron supporting wheels mounted on said shaft and provided with notches which are adapted to receive said supporting bars and thereby permit the apron to rest directly upon the periphery of said supporting wheels and means for operating the apron substantially as described.

In testimony whereof I hereunto affix my signature in presence of two witnesses.

WILLIAM WHITE.

Witnesses:

R. T. SMITH,  
JOSEPH L. CLOUGH.