



INTERNATIONAL APPLICATION PUBLISHED UNDER THE PATENT COOPERATION TREATY (PCT)

<p>(51) International Patent Classification ⁷ : B01D 33/04, 33/46, 33/50, 33/80</p>	<p>A1</p>	<p>(11) International Publication Number: WO 00/62896 (43) International Publication Date: 26 October 2000 (26.10.00)</p>
<p>(21) International Application Number: PCT/GB00/01400 (22) International Filing Date: 20 April 2000 (20.04.00) (30) Priority Data: 9908898.1 20 April 1999 (20.04.99) GB (71) Applicant (for all designated States except US): ROBBINS & MYERS LTD. [GB/GB]; School Lane, Chandlers Ford, Hampshire SO53 3DG (GB). (72) Inventors; and (75) Inventors/Applicants (for US only): RAY, David [GB/GB]; School Lane, Chandlers Ford, Hampshire SO53 3DG (GB). BROOKWELL, Richard [GB/GB]; School Lane, Chandlers Ford, Hampshire SO53 3DG (GB). BAYLEY, Geoffrey [GB/GB]; School Lane, Chandlers Ford, Hampshire SO53 3DG (GB). SNOW, Martin [GB/GB]; School Lane, Chandlers Ford, Hampshire SO53 3DG (GB). WEBB, Andrew [GB/GB]; School Lane, Chandlers Ford, Hampshire SO53 3DG (GB). (74) Agent: BAILEY WALSH & CO; 5 York Place, Leeds LS1 2SD (GB).</p>		<p>(81) Designated States: AE, AL, AM, AT, AU, AZ, BA, BB, BG, BR, BY, CA, CH, CN, CU, CZ, DE, DK, EE, ES, FI, GB, GD, GE, GH, GM, HR, HU, ID, IL, IN, IS, JP, KE, KG, KP, KR, KZ, LC, LK, LR, LS, LT, LU, LV, MA, MD, MG, MK, MN, MW, MX, NO, NZ, PL, PT, RO, RU, SD, SE, SG, SI, SK, SL, TJ, TM, TR, TT, UA, UG, US, UZ, VN, YU, ZA, ZW, ARIPO patent (GH, GM, KE, LS, MW, SD, SL, SZ, TZ, UG, ZW), Eurasian patent (AM, AZ, BY, KG, KZ, MD, RU, TJ, TM), European patent (AT, BE, CH, CY, DE, DK, ES, FI, FR, GB, GR, IE, IT, LU, MC, NL, PT, SE), OAPI patent (BF, BJ, CF, CG, CI, CM, GA, GN, GW, ML, MR, NE, SN, TD, TG).</p> <p>Published <i>With international search report.</i></p>
<p>(54) Title: SEPARATION SCREENING APPARATUS</p>		
<p>(57) Abstract</p>		
<p>Screening apparatus for a liquid containing solids comprising a screen with a series of perforations to allow liquid to pass therethrough and at least some solid matter to be collected on the screen. The screening apparatus includes means for movement of the screen and the screen is formed of sheet material in contact with drive means, which moves the sheet material in a direction which may in one embodiment be substantially in line with the flow of the liquid containing solids or, in another embodiment, lies perpendicular to the direction of flow.</p>		

FOR THE PURPOSES OF INFORMATION ONLY

Codes used to identify States party to the PCT on the front pages of pamphlets publishing international applications under the PCT.

AL	Albania	ES	Spain	LS	Lesotho	SI	Slovenia
AM	Armenia	FI	Finland	LT	Lithuania	SK	Slovakia
AT	Austria	FR	France	LU	Luxembourg	SN	Senegal
AU	Australia	GA	Gabon	LV	Latvia	SZ	Swaziland
AZ	Azerbaijan	GB	United Kingdom	MC	Monaco	TD	Chad
BA	Bosnia and Herzegovina	GE	Georgia	MD	Republic of Moldova	TG	Togo
BB	Barbados	GH	Ghana	MG	Madagascar	TJ	Tajikistan
BE	Belgium	GN	Guinea	MK	The former Yugoslav Republic of Macedonia	TM	Turkmenistan
BF	Burkina Faso	GR	Greece	ML	Mali	TR	Turkey
BG	Bulgaria	HU	Hungary	MN	Mongolia	TT	Trinidad and Tobago
BJ	Benin	IE	Ireland	MR	Mauritania	UA	Ukraine
BR	Brazil	IL	Israel	MW	Malawi	UG	Uganda
BY	Belarus	IS	Iceland	MX	Mexico	US	United States of America
CA	Canada	IT	Italy	NE	Niger	UZ	Uzbekistan
CF	Central African Republic	JP	Japan	NL	Netherlands	VN	Viet Nam
CG	Congo	KE	Kenya	NO	Norway	YU	Yugoslavia
CH	Switzerland	KG	Kyrgyzstan	NZ	New Zealand	ZW	Zimbabwe
CI	Côte d'Ivoire	KP	Democratic People's Republic of Korea	PL	Poland		
CM	Cameroon	KR	Republic of Korea	PT	Portugal		
CN	China	KZ	Kazakstan	RO	Romania		
CU	Cuba	LC	Saint Lucia	RU	Russian Federation		
CZ	Czech Republic	LI	Liechtenstein	SD	Sudan		
DE	Germany	LK	Sri Lanka	SE	Sweden		
DK	Denmark	LR	Liberia	SG	Singapore		
EE	Estonia						

Separation Screening Apparatus

The invention to which this application relates is a screening apparatus which allows solid and/or other waste material to be separated from a liquid containing solids which impacts onto the screen. The use of screens is relatively well known in sewage, food processing and any form of industry where a solid matter is collected in liquids and required to be separated therefrom.

There are many different types of solid separation plants which are designed for specific purposes and, in this invention, the apparatus is for screening solid matter from a liquid and moving said solid matter to a point for collection or passage into another flow of liquid, to another solids transfer device or subsequent return to the existing flow.

The aim of the present invention is to provide a screening apparatus which allows for the screening of the solid material from liquid and movement in an efficient manner of the material to a point for collection and/or movement into another flow of liquid, to another solids transfer device or subsequent return to the existing flow..

In a first aspect of the invention there is provided screening apparatus for a liquid containing solids comprising a screen with a series of perforations to allow liquid to pass therethrough and at least some of the solid matter to be collected on the screen, means for movement of the screen and wherein the screen is formed of sheet material in contact with drive means which move the sheet material in a direction to allow the flow of the liquid therethrough and on which at least some of the solid matter is trapped.

Typically the perforations are circular but may alternatively be slotted or any other desirable aperture shape. The size of the

apertures can be selected to suit particular screening and solids trapping requirements.

In one embodiment the screen is arranged with respect to the flow of liquid and solid matter so that the direction of flow of the liquid with solids is substantially in line with the movement of the screen.

In one embodiment the direction of movement of the screen is the same as the direction movement of the liquid containing solids.

In an alternative embodiment the direction of movement of the screen is the opposite to the direction of movement of the liquid containing solids. However preferably said movement of the screen in an opposite direction occurs during pre-determined intervals of the time that the screen is in operation

Typically the solids are screened in this embodiment by the liquid component passing through the perforations to the side due to the differential in pressure on the facing and reverse faces of the sheet material which makes up the screen which encourages the passage of the liquid component through the perforations. The solid matter is prevented from passing through the screen and is trapped on the surface of the screen and prevents passage of the solids through the screen.

It should be noted that in many potential uses of the screen it is not necessary for all of the liquid which passes the screen to pass through the perforation but rather for the screen to act as a means for removing liquid from a channel which is excess to the normal flow perhaps, if the liquid is water, due to storm or flood conditions and to allow the removal of the liquid without the solids matter accompanying the same.

As the screen, in one embodiment of use, is provided for use in dealing with exceptionally high volumes of liquid, it is undesirable for the screen to be operating in normal conditions and so the same can be controlled by liquid level sensors which operate the screen for movement when the level of the liquid and solid matter reaches a certain height and stops the screen when the level falls below a specified height. In one embodiment the screen forms at least a portion of a side wall of a channel or passage along which the liquid and solid flows.

Typically, the screen is arranged for use so that the face of the screen lies in a substantially vertical plane as it moves substantially in line with the flow of the liquid and solid matter. The screen may also be moved in the opposite direction to the flow of liquid, either during the whole of the time that the screen is in operation or for pre-determined intervals during the period of operation.

In an alternative embodiment the screen apparatus may be arranged so that the screen is substantially perpendicular to the direction of the liquid flow. The liquid passes through the perforations and the solid matter is trapped on the surface of the screen. The screen moves in an upward direction to transfer solids out of the liquid flow to a discharge point.

The screen may also be arranged so that its face is at an inclined angle to the vertical plane, projecting into the flow.

In one embodiment, the screen is in the form of a belt which is moved along the area or channel along which the liquid and solid matter moves, and the belt is moved by rollers mounted at each end of the belt. In one preferred embodiment the belt is a continuous belt inasmuch that there are no gaps in the belt. In one form the belt is formed by a length of material whose ends are joined to form

the continuous function, or alternatively the belt is formed from a series of panels held in a position so that respective adjacent ends of the panels are joined or abut one another. The screen may be fitted with raised 'flights' regularly spaced along the length of the screen, the purpose of which is to assist the transfer of solids to the discharge point.

In one form the belt is formed from plastics material with a series of perforations formed therein or alternatively can be formed from stainless steel sheet or yet further can be provided from a composite material again with perforations formed therein. Typically the perforation size and pattern of location will be dependant upon the screening efficiency required and the materials to be screened. In one embodiment the composite material can include a layer of KEVLAR (RTM).

In one embodiment the screen is provided with two or more drive and/or guide belts which can be provided to act as means for engagement with the drive rollers to impart a driving force and/or a guiding means for the screen. The drive and/or guide belts can be laminated or otherwise joined to the screen and, if used as drive belts, provided with teeth to engage the drive. Alternatively, chains may be fitted to the screen to act as means for engagement with the drive rollers or sprockets that are fitted with teeth to engage with the chains.

In one embodiment tensioning means are provided to allow the screen to be kept and held to the required tension so as to maintain screening efficiency during operation.

Specific embodiments of the invention will now be described with reference to the accompanying drawings, wherein:-

Fig. 1 illustrates a plan of the screening apparatus according to one embodiment of the invention;

Fig. 2 illustrates an elevation of the apparatus of Fig. 1;

Fig. 3 illustrates a detailed view of a drive arrangement for the screen; and

Figure 4A-4C – illustrate a side view, elevation and plan respectively of a further embodiment of the invention.

Referring firstly to Figs. 1 and 2 there is illustrated screening apparatus 2 for the separation of solid matter from a liquid for use for Combined sewage overflow applications and/or storm water discharge channels where the liquid and solid matter moves along a channel substantially in line with the movement of the screen 6 in the direction of arrow 4.

Referring to Fig.3 this shows one embodiment of the screening apparatus when used in combined sewage overflow applications and/or storm water discharge channels 28. The apparatus is mounted in a weir 27.

The screening apparatus comprises a screen 6 formed as a continuous belt and passing round rollers 8 and 10 both or either of which can be provided to drive the belt. The screen is provided to move in the direction of arrow 12 so that it moves substantially in line with the direction of flow 4 of the liquid to be separated. The screen can be formed of plastics material or a composite plastics material or stainless steel and in whichever embodiment may include drive and/or guide belts 16 and/or chains at spaced intervals.

The screen is provided with a series of apertures 18, shown for illustration purposes in the top left hand corner of the screen in Fig. 2, but which will in practice be spaced all over the screen and it has been found that although the size of the perforated apertures can be of any size to suit particular requirements, the provision of 6mm diameter circular perforations meets the standard requirements for use in storm water applications. The perforations are provided to allow the liquid to pass through the screen with the solids material being retained on the surface of the screen and moved, along with movement of the screen to a collection point at one side of the apparatus and/or for placement in another flow of liquid. The screen may be fitted with raised flights 26 regularly spaced along the length of the screen, the purpose of which is to assist the transfer to the discharge point. The screen can be provided with scraper bars, rotating cleaning brush 24 or other means for discharging the solids material from the screen into a collection means or back into the main flow downstream of the screen so that it will be appreciated that in the use described the screen is provided to allow for the removal of excess water without solids matter.

In a further embodiment an air diffuser pipe 25 may be fitted and orientated so that the air is blown through the screen from the liquid discharge side of the screen. The purpose of the air diffusion is to aid the cleaning of solids from the surface of the belt.

The apparatus further comprises a frame which can be used to support the screen and improve the general apparatus and upon which are mounted the rollers for providing drive to the screen and a drive motor 22 for controlling the speed of the rollers.

Another embodiment of the screening apparatus is shown in Figures 4a, 4b and 4c where the plane of the screen 6 is substantially perpendicular to the direction of flow 4. The direction of travel 12

of the screen 6 is such that separated solids are elevated out of the liquid flow to the solids discharge point 29. The screen 6 may be cleaned by either a wash water spray bar 30 or a rotating cleaning brush 24 or a combination of both.

The screening apparatus may be fitted at varying angles to the base of the channel to optimise the efficiency of the screen in respect of the particular application in this embodiment.

In whichever embodiment, the drive arrangement can be by a number of means and two particularly attractive means are the use of tensioned rollers which can be used to particular advantage with plastics/composite belts and/or stainless steel belts which can be provided on the screen as hereinbefore described and engage with the drive rollers to drive the screen. A further alternative is to use chains to engage with the drive means.

Thus it has been found that the apparatus of the present invention is advantageous in terms of efficiency in removal of solid matter from liquid and the movement of the solid matter from the separation point to collection point.

Claims:-

1. Screening apparatus for a liquid containing solids comprising a screen with a series of perforations to allow liquid to pass therethrough and at least some of the solid matter to be collected on the screen, means for movement of the screen and wherein the screen is formed of sheet material in contact with drive means which move the sheet material in a direction to allow the flow of the liquid therethrough and on which at least some of the solid matter is trapped.
- 2 Screening apparatus according to claim 1 wherein the perforations can be circular, slotted or any suitable shape of aperture.
3. Screening apparatus according to claim 1 wherein the movement of the screen is substantially in line with the flow of the liquid containing solids.
4. Screening apparatus according to claim 3 wherein the direction of movement is the same as that of the liquid containing solids.
- 5 Screening apparatus according to claim 3 wherein the direction of movement is opposite to the direction of movement of the liquid containing solids.
6. Screening apparatus according to claim 5 wherein movement of the screen in an opposite direction occurs during pre-determined intervals of the time that the screen is in operation
7. Screening apparatus according to claim 3 wherein the screen lies in a substantially vertical plane.

8 Screening apparatus according to claim 3 wherein the screen forms at least a portion of a side wall of a channel along which the liquid with solids flows.

9 Screening apparatus according to claim 1 wherein the screen is substantially perpendicular to the direction of flow of the liquid containing solids.

10. Screening apparatus according to claim 9 wherein the screen moves in an upward direction to transfer solids out of the liquid flow to a discharge point.

11 Screening apparatus according to claim 1 wherein the screen is in the form of a belt and is moved along the area or channel in which the liquid and solid matter moves.

12 Screening apparatus according to claim 11 wherein rollers are provided at each end of the belt to move the same.

13 Screening apparatus according to claim 11 wherein the belt is a continuous belt.

14 Screening apparatus according to claim 1 wherein the screen is fitted with scraper bars, rotating cleaning brushes and/or the like to assist in the transfer of solid matter to a discharge point.

15 Screening apparatus according to claim 1 wherein the screen is fitted with raised flights spaced along the length thereof.

16 Screening apparatus according to claim 1 wherein two or more drive and/or guide belts are provided to act as means for engagement with the drive rollers to impart a driving force and/or guide means for the screen.

17 Screening apparatus according to claim 1 wherein tensioning means are provided to allow the screen to be kept and held to the required tension.

18 Screening apparatus according to claim 1 wherein the screen face is at an inclined angle to the vertical plane and projects into the liquid with solid matter.

19 Screening apparatus according to any preceding claim wherein at least one liquid level sensor is provided to enable actuation of the screen when the level of the liquid with solids reaches a pre-determined height and stopped when the same falls below a pre-determined height.

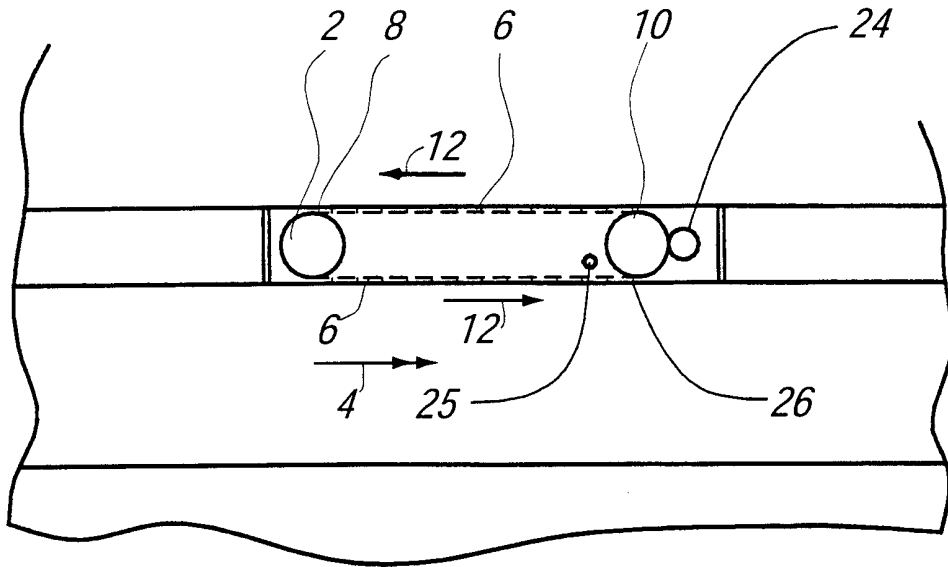

FIG. 1

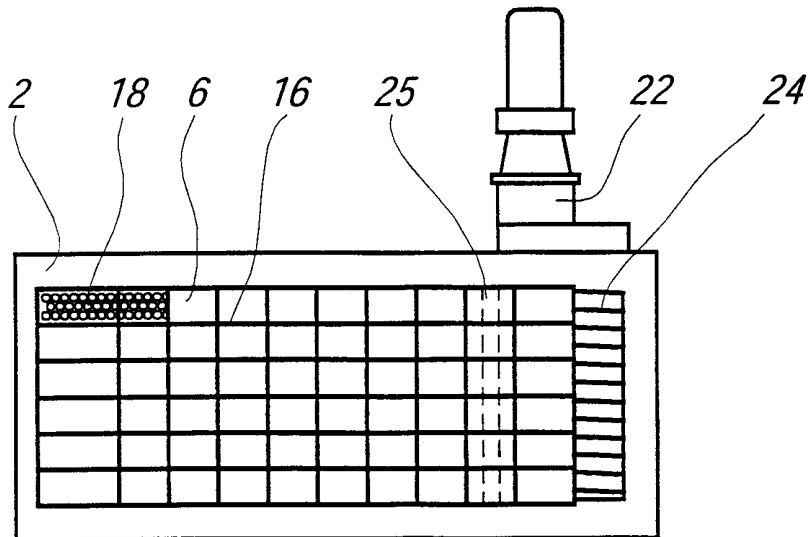

FIG. 2

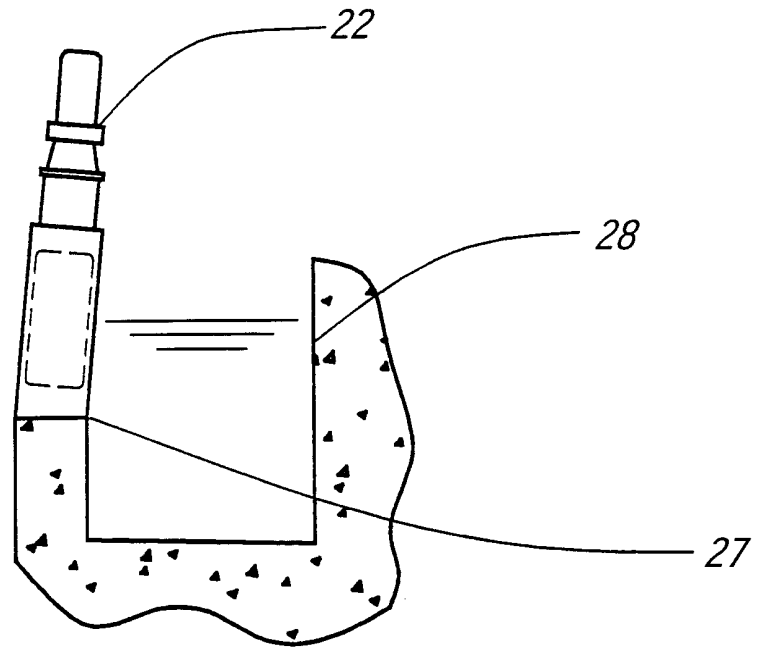

FIG. 3

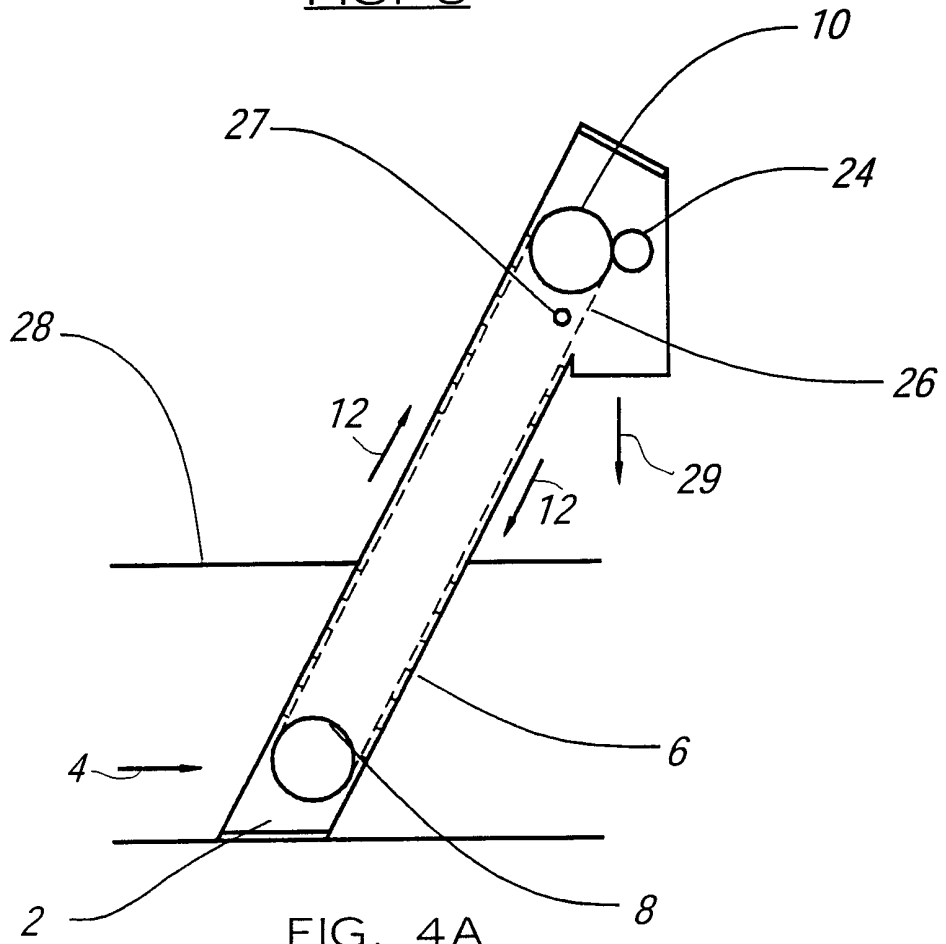

FIG. 4A

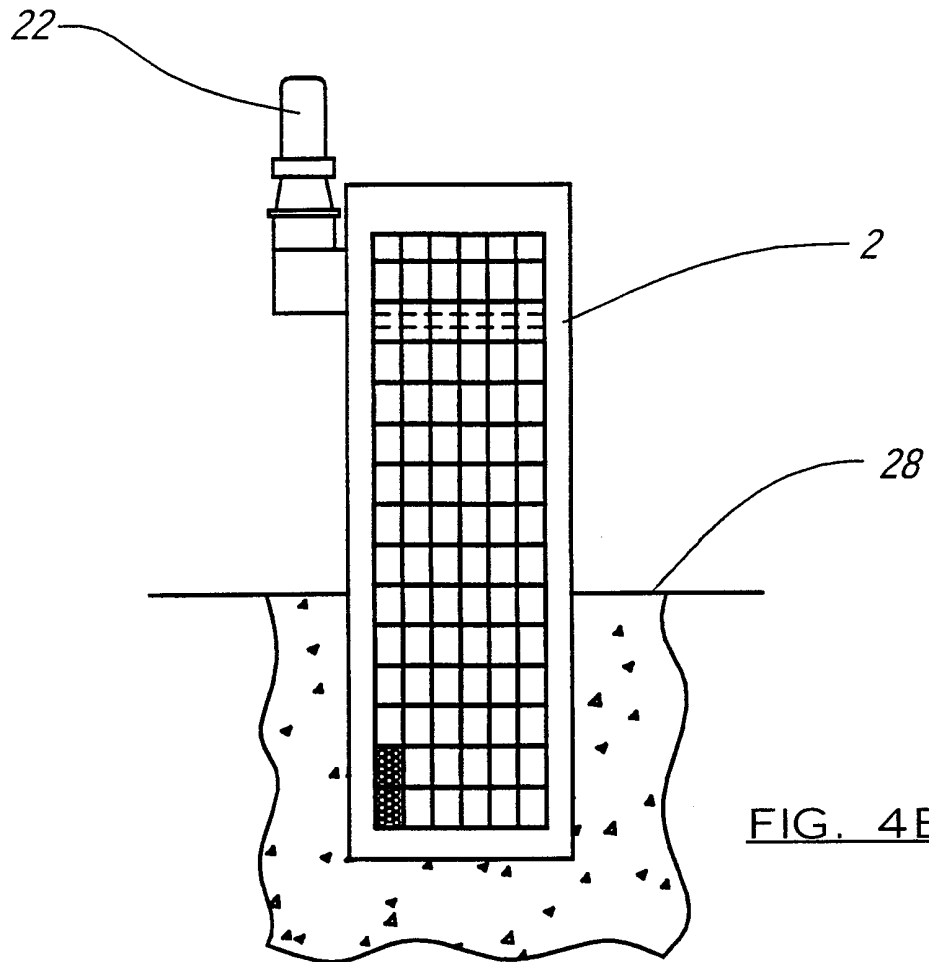

FIG. 4B

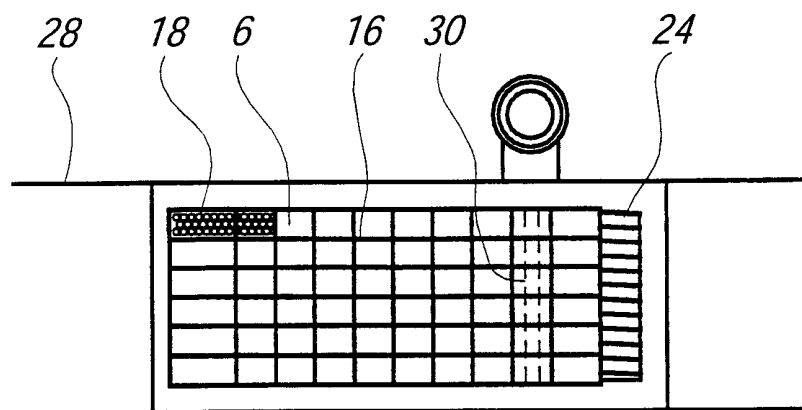

FIG. 4C

INTERNATIONAL SEARCH REPORT

International Application No

PCT/GB 00/01400

A. CLASSIFICATION OF SUBJECT MATTER

IPC 7 B01D33/04 B01D33/46 B01D33/50 B01D33/80

According to International Patent Classification (IPC) or to both national classification and IPC

B. FIELDS SEARCHED

Minimum documentation searched (classification system followed by classification symbols)

IPC 7 B01D

Documentation searched other than minimum documentation to the extent that such documents are included in the fields searched

Electronic data base consulted during the international search (name of data base and, where practical, search terms used)

EPO-Internal

C. DOCUMENTS CONSIDERED TO BE RELEVANT

Category °	Citation of document, with indication, where appropriate, of the relevant passages	Relevant to claim No.
X	DE 30 03 827 A (PASTOORS EDUARD ING GRAD) 13 August 1981 (1981-08-13) the whole document ---	1,2, 9-14, 16-19
X	FR 2 255 802 A (CHARD HUTCHINSON ABEL) 18 July 1975 (1975-07-18) the whole document ---	1,2, 9-14,18
X	US 5 618 415 A (JOHNSON JR RONALD L) 8 April 1997 (1997-04-08) abstract column 2, line 8 - line 23 column 3, line 7 -column 6, line 30 column 12, line 21 -column 13, line 53 claims figures ---	1,2, 9-16,18

Further documents are listed in the continuation of box C.

Patent family members are listed in annex.

° Special categories of cited documents :

- "A" document defining the general state of the art which is not considered to be of particular relevance
- "E" earlier document but published on or after the international filing date
- "L" document which may throw doubts on priority claim(s) or which is cited to establish the publication date of another citation or other special reason (as specified)
- "O" document referring to an oral disclosure, use, exhibition or other means
- "P" document published prior to the international filing date but later than the priority date claimed

- "T" later document published after the international filing date or priority date and not in conflict with the application but cited to understand the principle or theory underlying the invention
- "X" document of particular relevance; the claimed invention cannot be considered novel or cannot be considered to involve an inventive step when the document is taken alone
- "Y" document of particular relevance; the claimed invention cannot be considered to involve an inventive step when the document is combined with one or more other such documents, such combination being obvious to a person skilled in the art.
- "&" document member of the same patent family

Date of the actual completion of the international search

21 July 2000

Date of mailing of the international search report

31/07/2000

Name and mailing address of the ISA

European Patent Office, P.B. 5818 Patentlaan 2
NL - 2280 HV Rijswijk
Tel. (+31-70) 340-2040, Tx. 31 651 epo nl,
Fax: (+31-70) 340-3016

Authorized officer

Hilt, D

INTERNATIONAL SEARCH REPORT

International Application No
PCT/GB 00/01400

C.(Continuation) DOCUMENTS CONSIDERED TO BE RELEVANT		
Category *	Citation of document, with indication, where appropriate, of the relevant passages	Relevant to claim No.
X	EP 0 728 512 A (JONES & ATTWOOD LTD) 28 August 1996 (1996-08-28) the whole document ---	1,2,9-18
X	US 5 593 579 A (REYNOLDS MICHAEL L) 14 January 1997 (1997-01-14) abstract column 2, line 53 -column 3, line 21 column 4, line 7 - line 29 column 4, line 48 - line 57 column 5, line 60 -column 6, line 44 claims figures 1A,1B,2 ---	1-4, 11-14, 16,17
A	US 5 480 544 A (COTTAM ALAN) 2 January 1996 (1996-01-02) the whole document -----	1,3-5, 11-14,17

INTERNATIONAL SEARCH REPORT

Information on patent family members

International Application No

PCT/GB 00/01400

Patent document cited in search report	A	Publication date	Patent family member(s)	Publication date
DE 3003827	A	13-08-1981	NONE	

FR 2255802	A	18-07-1975	NONE	

US 5618415	A	08-04-1997	US 5573659 A	12-11-1996

EP 0728512	A	28-08-1996	AT 192667 T	15-05-2000
			AU 708448 B	05-08-1999
			AU 4564496 A	29-08-1996
			US 5676829 A	14-10-1997

US 5593579	A	14-01-1997	NONE	

US 5480544	A	02-01-1996	AT 141820 T	15-09-1996
			AU 3089492 A	19-07-1993
			BR 9206872 A	28-11-1995
			CA 2125163 A	24-06-1993
			DE 69213258 D	02-10-1996
			DE 69213258 T	23-01-1997
			DK 625066 T	09-12-1996
			EP 0625066 A	23-11-1994
			ES 2093859 T	01-01-1997
			FI 942578 A	30-06-1994
			WO 9311850 A	24-06-1993
			GB 2262244 A,B	16-06-1993
			GR 3021622 T	28-02-1997
			JP 7504842 T	01-06-1995
			NO 942077 A	03-08-1994
