

A. S. HOYT.
Grain Binder.

No. 110,138.

Patented Dec. 13, 1870.

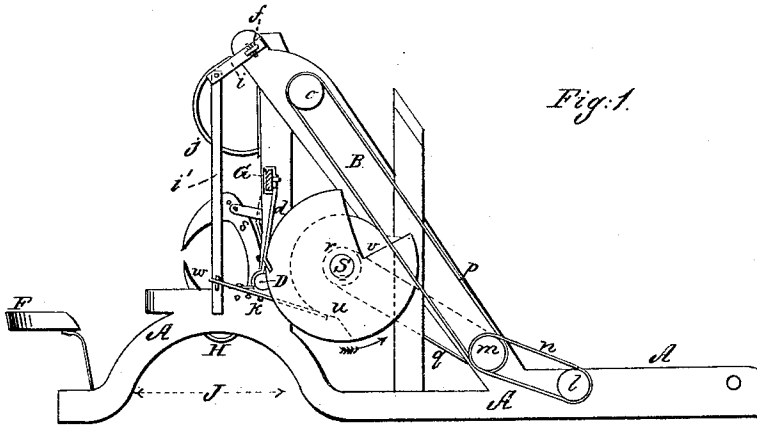

Fig. 1.

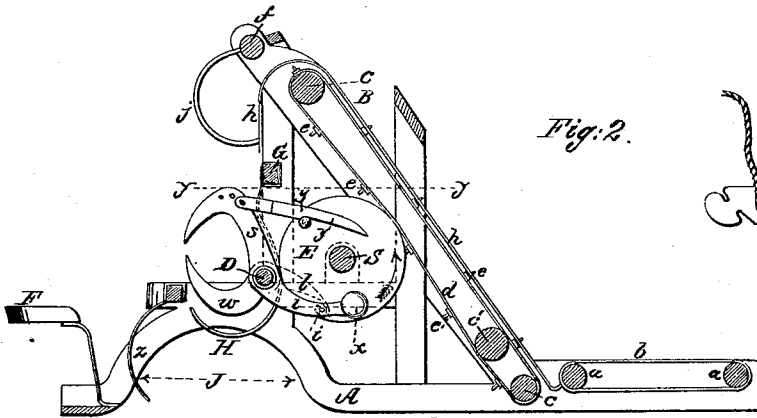

Fig. 2.

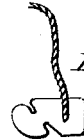

Fig. 4.

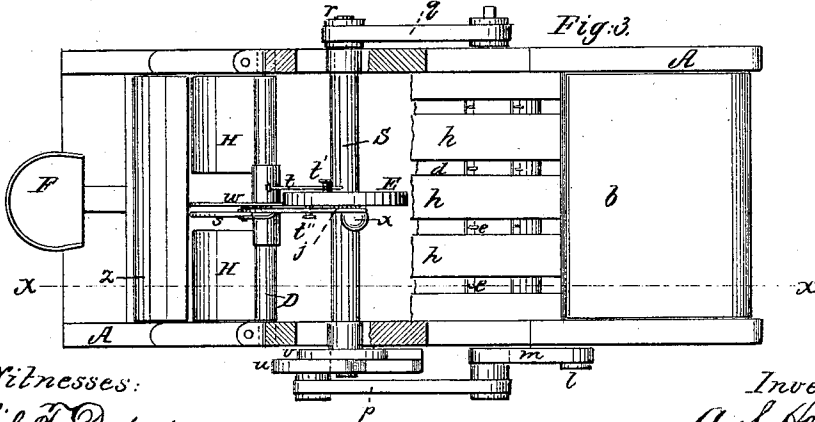

Fig. 3.

Witnesses:
Phil. T. Dodge
Thomas Taylor Jr.

Inventor:
A. S. Hoyt
by Dodge & Munn
his attys.

UNITED STATES PATENT OFFICE.

ALBERT S. HOYT, OF WINONA, MINNESOTA.

IMPROVEMENT IN GRAIN-BINDERS.

Specification forming part of Letters Patent No. **110,138**, dated December 13, 1870; antedated December 3, 1870.

To all whom it may concern:

Be it known that I, ALBERT S. HOYT, of Winona, in the county of Winona and State of Minnesota, have invented certain Improvements in Grain-Binders, of which the following is a specification, reference being had to the accompanying drawing.

My invention consists in a novel arrangement of automatic devices for compressing the grain into sheaves, holding the sheaves in a convenient position while being bound by an attendant riding upon the machine, and the delivering of the sheaves when bound from the machine, as hereinafter more fully described.

Figure 1 is a side elevation of my apparatus; Fig. 2, a longitudinal vertical section of the same, taken on the line *xx* of Fig. 3; and Fig. 3 is a top plan view of the same.

A is the frame of my binder and dropper, made of a shape to adapt it for supporting the mechanism, and of such form and size that it can be readily connected to a mowing-machine. Across the frame, at some distance apart, are mounted two parallel rollers, *a*, carrying an endless apron, *b*, onto which the grain is delivered from the cutters, which latter are arranged along or parallel with the side frame of A. Upon the frame A is mounted an inclined frame B, in each end of which is mounted a horizontal roll, *c*, and upon these rolls *c* is mounted an endless apron, *d*, provided with transverse slats *e*, having projecting pins or teeth upon them, as shown in Figs. 2 and 3. Above and parallel with the apron *d* is arranged a series of stationary strips or slats, *h*, having their lower ends secured to a transverse bar under the rear end of apron *b*, and having their upper ends carried over the upper end of apron *d*, as shown in Fig. 2, these strips *h* being so arranged that as the apron *d* revolves its teeth pass up between and project out beyond the face of the strips, as shown in Figs. 2 and 3, so that as the apron revolves the teeth take the grain as it is delivered from the apron *b* and carry it upward and over the ends of the strips *h*.

In the upper end of frame B is mounted a rock-shaft, *f*, provided with a series of wire arms, *j*, which are so curved as to form a receiver for the grain as carried over by the

teeth of apron *d*. The rock-shaft *f* has connected with it suitable mechanism, hereinafter described, by which it is at stated intervals turned so as to throw up the teeth *j* and discharge the accumulated grain therein.

Across the rear side of frame B is mounted another rock-shaft, G, having suspended from it a sheet-metal concave or hopper, H, into which the grain is delivered from the arms *j* in proper quantities to form sheaves. The natural position of this concave, when hanging free, is back of the line of arms *j*, so that the grain from the arms *j* would fall past it onto the ground, but it is held forward to receive the grain by means of an arm on shaft G, hereinafter described, which arm is released at proper times to let the concave swing back and discharge the sheaf upon the ground. The upper roll *c* is provided on its outer end with a pulley, *o*, which is connected by a driving-belt, *p*, with a pulley, *m*, on the end of a cross-shaft, *c'*, and this latter pulley is also connected by a belt, *n*, with the rear shaft *a*, as shown in Figs. 1 and 3, so that the aprons *b* and *d* shall move in unison.

Across the frame B is mounted a fixed rod or shaft, D, having mounted at its middle two independent curved arms, *s* and *w*, the former having a weight, *x*, on its rear end, which serves to keep it turned upward, while the latter is allowed to hang down through an opening in the concave H, made for the purpose, these arms being for the purpose of compressing the grain in the concave, as hereinafter described. Behind and parallel with the shaft D is mounted a rotating shaft, S, provided at one end with a pulley, *r*, and operated by a belt connecting said pulley with a pulley on the end of the cross-shaft *c'*, as shown, and on the middle of shaft S is mounted a fixed pulley, E, having on one side a pin, *t'*, and on the opposite side a similar pin, *t''*. (Shown in Figs. 2 and 3.)

The lower compressing-arm *w* is provided with a rear extension, *t*, and the upper arm *s* with a pivoted arm, *y*, having a notch or shoulder, *y'*, on its under side. As the wheel E revolves, the pin *t'*, striking the arm *t*, throws up the lower compressor-arm *w*, while at the same time the pin *t''*, engaging under the shoulder of arm *y*, forces down the upper

arm *s*, and thus the two arms *s* and *w* compress the grain in the concave between them.

When the stud *t'* has passed the arm *t*, the arm *w* falls back to its original position, and as soon as the end of arm *y* strikes upon the shaft *S*, the pin *t''* disengages from the arm, and the weight *x* throws up the arm *s* to its former position.

To the end of shaft *f* is attached an arm, *i*, connected by a rod, *i'*, with a lever, *k*, pivoted at its middle to frame *A*, and to the end of shaft *S* are attached two cam-wheels, *u* and *v*, the latter of which serves to trip the lever *k* once in each revolution, and thereby throws up the arms *j* and discharges their contents into the concave *H*. To the end of rock-shaft *G* is attached an arm, *a'*, which bears against the face of cam *u*, which latter holds it in a proper position to keep the concave *H* forward, except for a short time during each revolution of the cam, when the arm is released and the concave is permitted to swing back and discharge its contents.

Motion is imparted to the devices described from the mechanism of the mower in any convenient and suitable manner, this forming no part of my present invention.

Upon the end of the frame is mounted a binder's seat, *F*, and in front of this seat is secured a shield, *z*, which prevents the sheaves from falling in such position from the concave as to be caught by the frame in its passage over them, the frame being curved or cut away on one side, as shown at *J*, to insure its clearance of the sheaves.

The various parts are so arranged and timed that when a proper amount of grain has accumulated in the arms *j* to form a sheaf, the arms are thrown up and the grain discharged into the concave *H*, and then the

arms fall back to be again filled. As soon as the grain is discharged into the concave, the arms *s* and *w* compress and hold it, while the attendant occupying seat *F* binds. When sufficient time has elapsed for binding the sheaf, the arms open and leave the bound sheaf lying in the concave. The concave then drops back and discharges the sheaf onto the ground and is immediately brought up again to receive another supply from the arms *j*, which have been filled in the mean time, and so on continuously.

In binding the grain, I prefer to use a slotted block with a cord attached thereto, similar to that shown in Fig. 4, as I find this to be the most expeditious plan; but it is obvious that, if desired, straw, cord, or wire or other styles of binders may be used, these constituting no part of my invention.

Having thus described my invention, what I claim as new, and desire to secure by Letters Patent, is—

1. The combination of the compressor-arm *s*, provided with the counter-weight *x* and hinged arm *y*, with the arm *w*, provided with the lever *t*, and the wheel *E*, provided with the pins *t'* and *t''*, when said parts are arranged to operate substantially as set forth.

2. The hinged concave or grain-receiver *H* and arm *a'*, in combination with the cam-wheel *u*, when arranged to operate substantially as and for the purpose set forth.

3. The shield *z*, in combination with the curved frame *A*, to permit the machine to pass over the bundles without injury, substantially as described.

ALBERT S. HOYT.

Witnesses:

F. BELFOY,
J. B. ATKINSON.