

ORGANISATION AFRICAINE DE LA PROPRIETE INTELLECTUELLE  
(O.A.P.I.)



19

11 N°

11668

51 Inter. Cl. 7

A01G 13/02

BREVET D'INVENTION

21 Numéro de dépôt : 1200100099

22 Date de dépôt : 18.10.1999

30 Priorité(s) : NL  
21.10.1998 N° 1010368

24 Délivré le : 27.12.2001

45 Publié le : 05 JAN 2005

73 Titulaire(s) :

LAC Holding B.V.  
Meerpaal 5  
NL-4904 SK OOSTERHOUT (NL)

72 Inventeur(s) :

ADRIAANSE Cornelis Theodorus Jozef Maria  
Burg. den Oudenstraat 9  
NL-5076 GS HAAREN (NL)

74 Mandataire : CABINET J. EKEME  
B.P. 6370  
YAOUNDE - Cameroun

54 Titre : Agent for covering a soil surface.

57 Abrégé : The invention relates to an agent for covering a soil surface, containing water, coal-black, a binding agent, a strengthening agent and fibres, wherein the agent contains a copolymer of at least one alkene and at least one ester of an alkenoic acid as strengthening agent. Further, the invention relates to a process for preventing the growth of weeds by using the agent. Finally, the invention relates to a spraying installation for spraying a fluid agent for covering a soil surface.

Title: Agent for covering a soil surface.

Description.

5 The present invention relates to an agent for covering a soil surface, containing water, coal-black, a binding agent, a strengthening agent and fibres.

10 Such an agent is known from Netherlands Patent No. 1002374, and is used for preventing the growth of weeds. For this purpose, the known agent is applied in a fluid form on a soil from which weeds have been essentially removed and in which desirable ornamental plants or crop plants are already growing. A binding agent, for instance water glass, is present in order to keep the fluid form of the agent in a homogeneous state. By evaporation on the soil, the agent becomes solid, and prevents the growth of weeds, in that it, among other things, prevents the passage of light by the presence of coal-black, thereby inhibiting the photo-  
15 synthesis of any germinating weeds. A strenghtening agent provides firmness to the dried form of the agent. The solid form of the agent is permeable to air and water. Such an agent is biodegradable and does not lead to environmental pollution.

20 Research by applicant has shown that the effectivity of the known agent is not fully satisfactory, as the known agent, applied to the soil, is too weak, particularly in a wet condition. As it is also insufficiently light-proof, it offers insufficient resistance to any germinating weeds. As in the known agent protein products are present for strengthening purposes, its storage life is limited and it furthermore  
25 causes inconvenience by its smell when it is being applied on the soil.

An agent which, in an evaporated condition, leads to a better covering layer with a higher firmness and flexibility can be obtained through the invention, which is characterised in that the agent contains a copolymer of at least one alkene and at least one ester of an alkenoic acid as strengthening agent.  
30

U.S. Patent 4.705.816 relates to an agent containing a polymer, which forms a friable crust which is not continuous and which is readily broken by mechanical action. It generally provides a means for enhancing crop production. The agent can contain herbicides if the growth  
35 of weeds is to be prevented. If the agent has a dark colour, it helps the

seeds to germinate faster by increasing the soil temperature. The agent does not contain any fibres. U.S. Patent 4.297.810 relates to an agent which is effective in reclaiming land, and which is particularly useful in planting seed. The agent does not contain a copolymer. Any coloring agents are used chiefly for esthetic purposes, in that they serve no mechanical or organic purpose in the composition. FR 1.576.858 relates to an agent which is pulverised on plants. The agent does not contain coal-black or fibres. It forms a mesh around plants, thereby protecting them against insects and other pests.

According to the invention, particularly good results were obtained when using an agent in which the copolymer is a copolymer of ethylene and vinyl acetate.

It was shown that the agent according to the invention when applied to the soil and dried, is more firm and flexible by the presence of the copolymer of ethylene and vinyl acetate, which results in the fact that it can be better walked upon. Obviously, an increased walkability is desirable, as it is then for instance easier to walk on the treated soil, in order to take care of the aforementioned ornamental plants or crop plants. The agent according to the invention is also effective for a longer time. An additional advantage of the copolymer of ethylene and vinyl acetate is that it promotes the wet strenght.

Research carried out by applicant shows that it is preferable that the copolymer is present in an amount of 1-20 % by weight of the agent.

In order to maintain the agent during transport to the place of use, or in otherwise physically straining circumstances, it was shown that the presence of xanthane gum is preferable. Additional advantages of xanthane gum are that it has a thixotropic action and that it is a natural product. Particularly good results are obtained if xanthane gum is present as an auxiliary agent in an amount of 0.02-2 % by weight of the agent.

Cotton fibres are particularly convenient as fibres. Not only are they natural, biodegradable fibres, but they also have a good wet strength. Natural fibres such as cotton fibres are preferably present in the agent in an amount of 0.2-6 % by weight of the agent.

Not only do coconut fibres have the same favourable properties as do cotton fibres, but they also provide the advantage of providing a better binding of coal-black, so that the dried agent with coconut fibres is even less permeable to light. It is preferred that the agent also contains coconut fibres in an amount of 0.1-5 % by weight of the agent.

In order to further improve the wet strength of cotton fibres, which as such as already good, it is preferable that a product for improving the wet strength is present in an amount of 0.01-1 % by weight of the agent. An example of such an agent is a polyamidoamine/-epichlorhydrin resin such as Cartabond(trademark).

A possible coagulation of the fibres in the agent can be countered by the presence of 0.05-5 % by weight of a surface active compound, for instance a polysorbate such as Tween 80(trademark).

The growth of any germinating weeds can be inhibited even more effectively by incorporation in the agent of a substance which makes the trace elements which are necessary for germination unavailable by chelation. For this purpose, it is preferable that the agent contains a chelating substance in an amount of 0.01-1 % by weight of the agent. An example of a chelating substance is EDTA or a salt form thereof.

It is preferable that the agent, applied to the soil and dried, has the lowest possible susceptibility to fire. Research from applicant surprisingly shows that a clear fire-resistant effect is provided by using potassium water glass as binding agent. The potassium water glass, which provides the fire-resistant properties, is preferably present in an amount of 0.3-30 % by weight of the agent.

In order to better ensure the necessary density of the agent, it is preferable that a filler is present in the agent, for instance a (potassium, magnesium, iron, aluminum)-silicate such as Mica 200(trademark). As a carrier for the pigment coal-black, and also as a filler, potato starch can be present. By the presence of a vegetable oil, such as for instance soy oil, the good wet strength of the cotton fibres can be further enhanced, and the color of the agent can also be intensified.

The present invention also relates to a process for preventing the growth of weeds, by covering a soil surface which contains practically no weeds, but in which desirable ornamental plants or crop

plants are growing, with a fluid agent according to the invention, and then bringing the agent into a solid state by evaporation.

Preferably, the agent is applied to the soil using a spraying installation having a spraying pipe with at least two spraying nozzles with separate supply lines.

The present invention also relates to a spraying installation for spraying a fluid agent for covering a soil surface comprising a pump, an air compressor and a spraying pipe.

Such a spraying installation is also known from Netherlands Patent No. 1002374. Research by applicant shows that using the known spraying installation a spraying pattern is obtained which is insufficient to cover the soil with the agent.

The spraying installation according to the present invention is characterised in that the spraying pipe ends with a branching with at least two spray nozzles, which are separately connected with the pump and the air compressor.

In order to protect the spray nozzles against mechanical damage while applying the agent, it is preferable that the spray nozzles are protected by a device in the form of a cap which is connected to the spraying pipe. An additional advantage of this organ in the form of a cap is that, using said device, it is made possible to more or less push aside the existing planting of ornamental and/or crop plants while applying the agent, in order to apply the agent at the base of the plants without the agent noticeably ending up on, for instance, the leaves of existing plants.

In the accompanying drawing, an example of an embodiment of the spraying installation according to the present invention is illustrated. In a container (1) a fluid agent is present, which is fed in spraying pipe (4) using a pump (2) and an air compressor (3) in a manner which is known as such. The air is sucked in along the arrow (11a) and is fed to spray nozzles (6, 7) using the compressor (3). The air line indicated by arrow (11a) ends with a branching (5), the ends of which open into two spraying nozzles (6, 7). The agent is fed through spray nozzles (6, 7) via separate lines according to arrow (11b), using pump (2). The spray nozzles (6, 7) are each separately provided with feeding lines (9) for feeding air, and feeding lines (12) for feeding the agent. The spray nozzles can be protected by a device in the form of a cap (8), which for

instance consists of aluminium. When applying the agent on the soil, spraying pipe (4) can be moved with handles (10).

The present invention is further illustrated using the following examples.

5                    Examples.

Example 1.

                  The following constituents were thoroughly mixed in the given order: water (90.8 % by weight), cotton fibres (2 % by weight), potassium water glass (3.4 % by weight), coal-black (0.2 % by weight) and copolymer of ethylene and vinyl acetate (3.6 % by weight).

                  Using a spraying installation, the darkly coloured agent was applied on a soil in which ornamental plants were growing, and from which weeds were practically removed. The agent was hardened by evaporation, and inhibited the growth of weeds during one year. The walkability of the agent was good, so that the ornamental plants could be treated during the course of the year.

Example 2.

                  A fluid agent and contained the same constituents, was prepared as described in Example 1, except that the amount of water was 90.6 % by weight and that, prior to adding the copolymer, an amount of 0.2 % by weight of xanthene gum was mixed into the agent.

                  The thereby obtained agent could be maintained for a longer time, and also proved to be resistant to the mechanical influences of a lengthy transport to the place of use of the agent.

Example 3.

                  A fluid agent was prepared by thoroughly mixing the following constituents: water (76.2 % by weight), coal-black (0.2 % by weight), cotton fibres (2.5 % by weight), xanthane gum (0.2 % by weight), EDTA-2 Na (0.1 % by weight), potassium water glass (3.4 % by weight), Tween 80(trademark) (0.5 % by weight), potato starch (2.4 % by weight), vegetable oil (0.9 % by weight) and finally a copolymer of ethylene and vinyl acetate (3.6 % by weight).

                  The thereby obtained agent was much darker than the agents according to Examples 1 and 2.

Example 4.

A fluid agent was prepared by thoroughly mixing the following constituents: water (76.2 % by weight), coal-black (0.2 % by weight), cotton fibres (2.0 % by weight), coconut fibres (1.5 % by weight), xanthane gum (0.2 % by weight), EDTA-2 Na (0.1 % by weight), potassium water glass (3.4 % by weight), Mica-200(trademark) (0.2 % by weight) and finally copolymer of ethylene and vinyl acetate (3.6 % by weight).

The thereby obtained agent was much darker than the agents according to Examples 1 and 2.

Example 5.

A fluid agent was prepared by thoroughly mixing the following constituents: water (78.9 % by weight), coal-black (0.2 % by weight), cotton fibres (2.0 % by weight), coconut fibres (1.5 % by weight), xanthane gum (0.2 % by weight), EDTA-2 Na (0.1 % by weight), potassium water glass (3.4 % by weight), Mica-200(trademark) (0.2 % by weight), Cartabound(trademark) (0.1 % by weight) and finally copolymer of ethylene and vinyl acetate (3.6 % by weight).

By the presence of the latter constituent, the natural fibres had a clearly higher wet strength.

## Claims.

1. Agent for covering a soil surface, containing water, coal-black, a binding agent, a strengthening agent and fibres, characterised in that it contains a copolymer of at least one alkene and at least one ester of an alkenoic acid as strengthening agent.  
5
2. Agent according to claim 1, characterised in that the copolymer is a copolymer of ethylene and vinyl acetate.
3. Agent according to claim 1 or claim 2, characterised in that the copolymer is present in an amount of 1-20 % by weight of the agent.  
10
4. Agent according to any one of claims 1-3, characterised in that xanthane gum is present as an auxiliary agent, in an amount of 0.02-2 % by weight of the agent.
5. Agent according to any one of claims 1-4, characterised in that natural fibres, such as cotton fibres are present in the agent in an amount of 0.2-6 % by weight of the agent.  
15
6. Agent according to any one of claims 1-5, characterised in that coconut fibres also present in an amount of 0.1-5 % by weight of the agent.
7. Agent according to any one of claims 1-6, characterised in that it contains a compound for enhancing the wet strength of the fibres in an amount of 0.01-1 % by weight of the agent.  
20
8. Agent according to any one of claims 1-7, characterised in that it contains a surface active compound in an amount of 0.05-5 % by weight of the agent.  
25
9. Agent according to any one of claims 1-8, characterised in that it contains a chelating compound in an amount of 0.01-1 % by weight of the agent.
10. Agent according to any one of claims 1-9, characterised in that potassium water glass is present as binding agent in an amount of 0.03-30 % by weight of the agent.  
30
11. Agent according to any one of claims 1-8, characterised in that an auxiliary agent, belonging to the group consisting of potato starch, a vegetable oil, and/or a filling agent, is also present.

12. Process for preventing the growth of weeds, by covering a soil surface which contains practically no weeds, but in which desirable ornamental plants or crop plants are growing, with a fluid agent containing water, coal-black, a binding agent and fibres, and then bringing the agent into a solid state by evaporation, characterised in that the agent according to any one of claims 1-10 is used.

13. Process according to claim 12, characterised in that the agent is applied on the soil using a spraying installation having a spraying pipe with at least two spray nozzles with separated supply lines.

14. Spraying installation for spraying a fluid agent for covering a soil surface, comprising a pump, an air compressor and a spraying pipe, characterised in that the spraying pipe ends with a branching with at least two spray nozzles, which are separately connected with the pump and the air compressor.

15. Spraying installation according to claim 14, characterised in that the spray nozzles are protected by a device in the form of a cap which is connected to the spraying pipe.

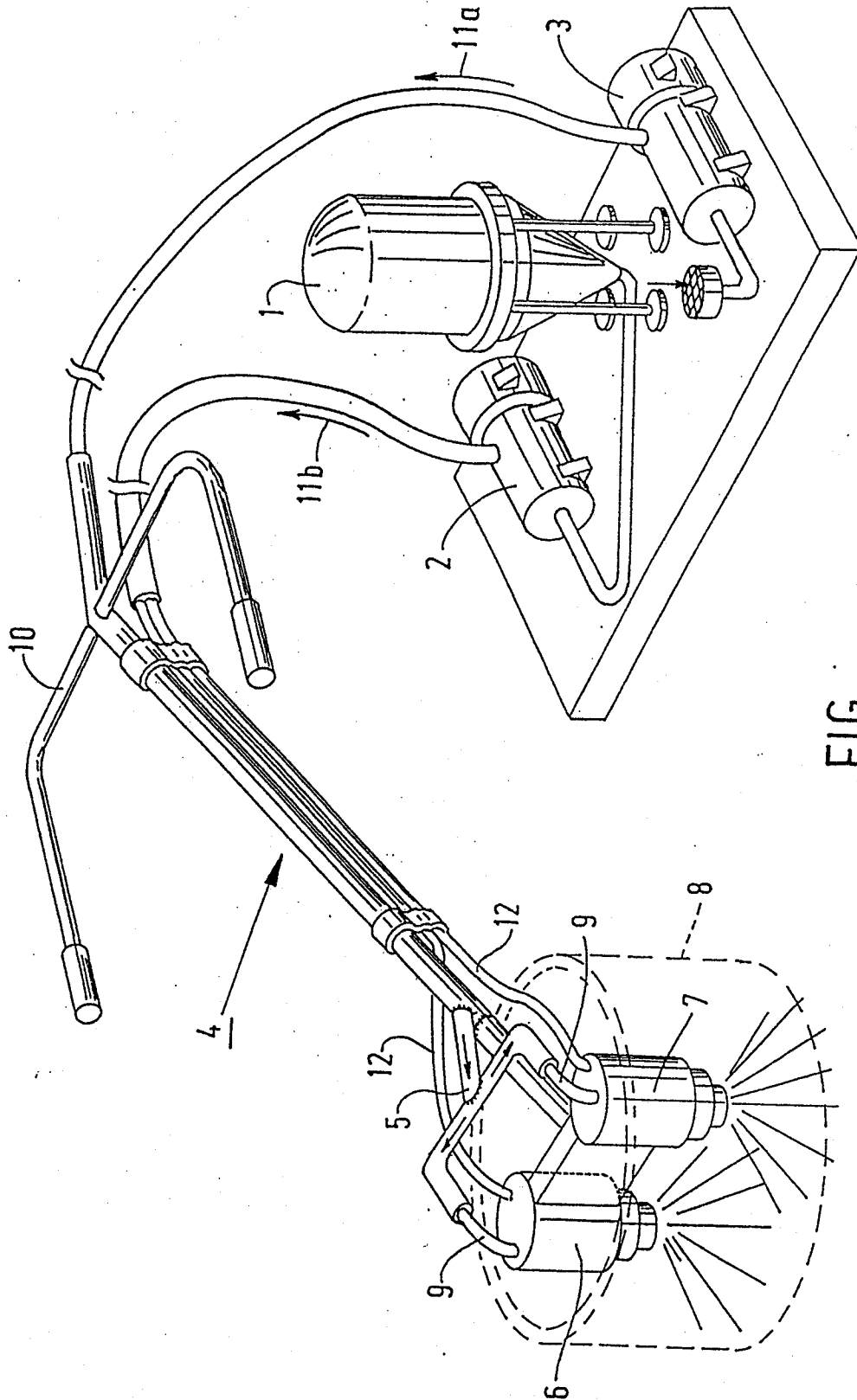

FIG.