

(19) World Intellectual Property Organization
International Bureau



(43) International Publication Date
8 March 2001 (08.03.2001)

PCT

(10) International Publication Number
WO 01/15638 A1

- (51) International Patent Classification⁷: **A61F 2/44**
- (21) International Application Number: PCT/US00/22939
- (22) International Filing Date: 21 August 2000 (21.08.2000)
- (25) Filing Language: English
- (26) Publication Language: English
- (30) Priority Data:
09/389,758 2 September 1999 (02.09.1999) US
- (71) Applicant: **CAUTHEN RESEARCH GROUP, INC.** [US/US]; Suite One, 6510 N.W. 9th Boulevard, Gainesville, FL 32605 (US).
- (72) Inventor: **CAUTHEN, Joseph, C.**; 8224 S.W. 28th Place, Gainesville, FL 32607 (US).
- (74) Agents: **BLUM, Seth et al.**; Saliwanchik, Lloyd & Saliwanchik, Suite A-1, 2421 N.W. 41st Street, Gainesville, FL 32626 (US).
- (81) Designated States (*national*): AU, BR, CA, CN, CR, HU, IL, IN, IS, JP, KP, KR, MX, NO, NZ, SG, TR, ZA.
- (84) Designated States (*regional*): European patent (AT, BE, CH, CY, DE, DK, ES, FI, FR, GB, GR, IE, IT, LU, MC, NL, PT, SE).

Published:
— *With international search report.*

For two-letter codes and other abbreviations, refer to the "Guidance Notes on Codes and Abbreviations" appearing at the beginning of each regular issue of the PCT Gazette.

(54) Title: ARTICULATING SPINAL IMPLANT

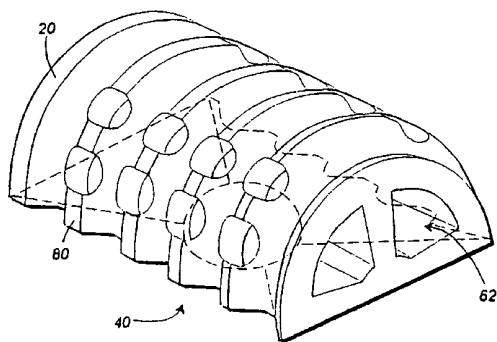

A

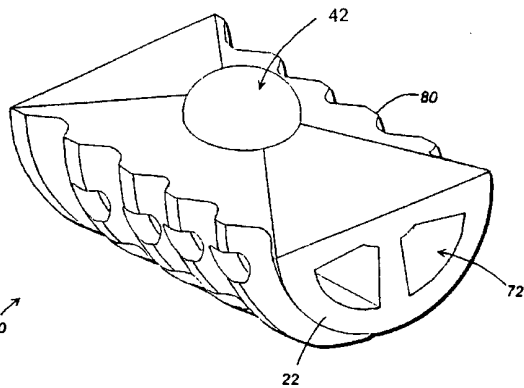

B

(57) Abstract: A spinal implant (10) for intervertebral disc replacement. The implant is formed from two hemicylindrical elements (20, 22), each engaging one of an adjacent pair of vertebrae (12, 14). An articulating ball-and-socket joint and/or rocker and channel between the two elements resists compression and lateral movement between the vertebra, but allows pivotal movement, thereby preserving mobility. Fusion chambers (30, 34) are provided for allowing bone ingrowth to fuse the elements to the vertebrae. Biocompatible, bioreabsorbable struts, shims (82), fillers and/or end caps (90) are provided for temporary stabilization of the first (20) and second (22) hemicylindrical elements. Bone chips removed from the vertebrae during implantation or bone growth stimulators can be inserted into the fusion chamber or otherwise applied to the implant to enhance bone ingrowth.

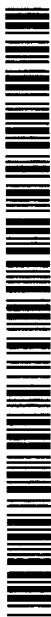

WO 01/15638 A1

DESCRIPTIONARTICULATING SPINAL IMPLANTCross-Reference to a Related Application

5 This application is a continuation-in-part of co-pending patent application Serial No. 09/298,524, filed 23 April 1999, which is a continuation-in-part of co-pending patent application Serial No. 09/065,816, filed 23 April 1998.

Background of the InventionField of the Invention:

10 The invention relates generally to a spinal implant for use in intervertebral disc replacement; and more specifically relates to an articulating implant that fuses to adjacent vertebrae by bone ingrowth, thus restoring proper intervertebral spacing, and eliminating nerve root and/or spinal cord compression, while preserving spinal flexibility.

Description of Related Art:

15 The spinal column is formed from a number of vertebrae, which in their normal state are separated from one another by cartilaginous intervertebral discs. These discs form a cushion between adjacent vertebrae, resisting compression along the support axis of the spinal column, but permitting limited movement between the vertebrae to provide the characteristic flexibility of the healthy spine. Injury, disease or other degenerative disorders may cause one or more intervertebral discs to shrink, collapse, deteriorate or become displaced, herniated or otherwise damaged. This can lead to compression of adjacent nerve root(s) or the spinal cord causing chronic and often disabling pain, and in advanced circumstances, irreversible paralysis of upper and/or lower limbs.

20 A number of devices and methods have been suggested for the replacement of damaged or dislocated intervertebral discs. One common approach is to permanently stabilize or "fuse" the adjacent vertebrae to maintain the proper intervertebral spacing and eliminate relative movement between the vertebrae. Various methods of vertebral stabilization have been developed. For example, autogenous grafts of dowel-shaped sections of bone have been implanted between the vertebrae to cause bone growth across the intervertebral space, thereby fusing the adjacent vertebrae into one bone mass. This procedure disadvantageously requires the harvest of donor bone for the graft from other parts of the patient's body, typically requiring

25
30

a separate surgical procedure and resultant increases in complications and expense. An alternative source is cadaver bone, with potential complications of transmissible diseases, impaired graft incorporation, collapse or displacement. A further development to this method of vertebral stabilization involves the implantation of a perforated cylindrical bone basket between adjacent vertebrae. Bone fragments produced in preparing the vertebrae for the implantation are inserted into the bone basket to promote bone growth into, through and around the basket.

Vertebral stabilization by fusion of adjacent vertebrae has proven successful in permanently preserving intervertebral spacing, but has been found to present a number of disadvantages. Fusion of adjacent vertebrae necessarily eliminates a portion of the spine's normal range of motion, thereby reducing the subject's spinal flexibility. Additionally, fusion of the vertebrae increases the stresses imposed on adjacent mobile portions of the spinal column, often hastening the subsequent breakdown of normal joint surfaces above and below the fused vertebrae.

It has also been proposed to replace an injured intervertebral disc with a prosthesis which is "jointed" to permit relative movement between vertebrae. Previously-known devices of this type generally have been found to suffer from inadequate attachment between the prosthesis and the vertebrae. The intended movement between the components of previously-known jointed prostheses can cause relative motion between the prosthesis and adjacent bone surface(s). Because such motion would disrupt bone ingrowth, jointed prostheses have generally been considered incompatible with attachment by bone ingrowth. In addition, because the joint elements of these devices typically must occupy a substantial vertical extent in order to achieve the desired range of motion, and yet must fit within the intervertebral space, attachment of such devices generally has been by use of flat plates or surfaces provided on either side of the joint elements as points of fixation to the vertebrae. This attachment may be accomplished by compressive or friction fits, spiked projections, screws or pins, complemented in some instances with tissue ingrowth into porous surfaces. These mechanisms of attachment, however, may lack the degree and strength of fixation desired. Moreover, several such devices have used attachment flanges which extend beyond the surfaces of the vertebrae to which the device is attached. This has been found undesirable, as the extending flanges may interfere with or injure adjacent tissue. For example, it has been reported that flanges extending into immediately adjacent delicate esophageal area may interfere with swallowing and speech, or cause perforation and potentially fatal infection. An additional drawback to the use of screw and pin connections is the potential for such connectors to dislodge and cause injury.

Thus, it can be seen that a need yet exists for a spinal implant effective in permanently maintaining intervertebral spacing to prevent nerve or spinal cord compression while preserving as much of the natural range of motion between the affected vertebrae as possible. A need further exists for such a device which is capable of forming a permanent, strong attachment to the vertebrae and yet does not protrude beyond the external surfaces to which it is attached. Still another need exists for a method of replacing a damaged or displaced disc, which method maintains intervertebral spacing to prevent nerve and spinal cord compression, while preserving the natural relative motion between the vertebrae. It is to the provision of a device and method meeting these and other needs that the present invention is primarily directed.

Brief Summary of the Invention

Briefly described, in a preferred form, the present invention comprises a spinal implant including a first element having first connection means for engaging a first vertebra. The first connection means includes a first fusion chamber having at least one opening therein for facilitating bone ingrowth into the first fusion chamber to fuse the first element to the first vertebra. The implant also includes a second element having second connection means for engaging a second vertebra. The second connection means includes a second fusion chamber having at least one opening therein for facilitating bone ingrowth into the second fusion chamber to fuse the second element to the second vertebra. The implant also includes internal articulation means, coupling the first element to the second element, for allowing relative movement between the first element and the second element. The term "internal articulation means," is intended to mean a device that permits relative motion between components of the device, rather than between the device and an external structure such as adjacent bone or other tissue.

In specific embodiments of the subject invention, the first and second element may have either hemicylindrical or hemielliptical shaped outer surfaces. The first and second elements each having an outer wall perforated with one or more openings provided therein to allow bone ingrowth into the fusion chambers, and having abutting joint surfaces forming the internal articulation means. In a further preferred embodiment, the joint surfaces are formed as engaging concave and convex surfaces to create a ball-and-socket type joint (or groove and channel, or other such joint), which allows relative pivotal motion between the vertebrae, but resists compression therebetween.

The first and second elements can join to form a single element which can be implanted using methods similar to those followed in the implantation of previously-known non-articulating vertebral fusion implants. Temporary stabilizing means can be provided for rigidly

coupling the first and second elements by interposition of bioreabsorbable elements to permit implantation and enable bone ingrowth into the fusion chambers and fusion of the first and second elements to adjacent bone during an initial stabilization period, after which said temporary means biodegrades permitting articulation between the first and second elements.

5 The present invention can be further described as comprising a spinal implant having a first articulation surface, a second articulation surface engaging at least a portion of the first articulation surface along a support axis generally parallel to the spinal column, first connection means for connecting the first articulation surface to a first vertebra, and second connection means for connecting the second articulation surface to a second vertebra. The first and second articulation surfaces resist axial compression between the first and second elements in the direction of the support axis, but allow relative pivotal motion between the first and second elements. At least one, and preferably both, of the first connection means and the second connection means comprise a fusion chamber having at least one opening therein for facilitating bone ingrowth, thereby permanently and securely affixing the implant in place.

10 In another preferred form, the present invention comprises a method of maintaining an intervertebral space between a first vertebra and a second vertebra. The method includes the steps of removing a section of the first vertebra to form a cavity therein, mounting a first element of a spinal implant within the cavity formed in the first vertebra, and connecting a second element of the spinal implant to the second vertebra. The first element includes a first articulation surface and a first fusion chamber having at least one opening therein for facilitating bone ingrowth from the first vertebra. The second element includes a second articulation surface, wherein the first and second articulation surfaces adjoin to form a joint allowing relative pivotal movement between the first and second elements but preventing relative compression between the first and second elements. In a further preferred embodiment, the method may also include the removal of a section of the second vertebra to form a cavity for receiving the second element. The second element may also include a second fusion chamber for facilitating bone ingrowth from the second vertebra. Bone fragments formed by the removal of vertebral sections to accommodate implantation or bone growth stimulating compounds or devices may be inserted into the fusion chamber(s) to enhance bone ingrowth.

25 These and other objects, features and advantages of the present invention will be more readily understood with reference to the following detailed description, read in conjunction with the accompanying drawing figures.

Brief Description of the Drawings

Figure 1 shows a perspective view of a spinal implant according to one cylindrical form of the present invention.

Figure 2 shows a cross-sectional side view of the spinal implant of Figure 1.

Figure 3 shows a cross-sectional end view of the spinal implant of Figure 1.

Figure 4a is an end view of a spinal implant *in situ* according to the cylindrical form of the present invention.

Figure 4b is a side view of a spinal implant *in-situ* according to the cylindrical form of the present invention.

Figure 5 is a cross-sectional end view of another embodiment of the present invention.

Figure 6a shows a cross-sectional end view of an elliptically shaped spinal implant of the subject invention.

Figure 6b shows a cross-sectional end view of an alternative elliptically shaped spinal implant of the subject invention.

Figure 7 shows a cross-sectional side view of the tapered spinal implant.

Figure 8 shows a cross-sectional end view of a spinal implant with a rocker and channel articulating means.

Figure 9 shows a cross-sectional end view of a spinal implant with a rocker and hour-glass channel articulating means.

Figures 10a & 10b show a perspective view of a spinal implant with a rocker and alternative hour-glass channel articulating means.

Figures 11a & 11b show a perspective view of a spinal implant with a rocker and alternative hour-glass channel articulating means.

Figure 12 is an end view of a spinal implant *in-situ* according to the elliptical form of the present invention.

Figure 13 is a side view of a spinal implant *in-situ* according to the tapered form of the present invention.

Figure 14 shows a surgical instrument for cutting an elliptical section in between spinal vertebra.

Figures 15a & 15b show a perspective view of a spinal implant with an alternative diamond channel and corresponding diamond rocker articulating means.

Detailed Disclosure of the Invention

Referring now in detail to the figures wherein like reference numbers represent like parts throughout, preferred forms of the present invention will now be described. As seen in Figs. 1-3, one embodiment of the present invention comprises a spinal implant **10**, generally comprising a first element **20** and a second element **22**. The first element **20** is coupled to the second element **22** by an internal articulation means **24** for allowing relative pivotal movement between the first and second elements.

Figures 4A and 4B show the spinal implant **10** of the present invention installed *in situ*, between a first vertebra **12** and a second vertebra **14**. The implant **10** is shown implanted into an anterior aspect of the vertebral body, between the fifth cervical and sixth cervical vertebra. The device and method of the present invention, however, are applicable to anterior, lateral, and posterior approaches to the vertebrae.

As seen best in Figs. 2-3, the first element **20** of the implant **10** comprises first connection means, in the form of a first fusion chamber **30**, for engaging the first vertebra **12**. At least one opening **32** is formed in the first fusion chamber **30**, to facilitate bone growth into, through and around the first fusion chamber **30** from the first vertebra **12**, to fuse the first element to the first vertebra **12**. Preferably, a plurality of openings **32** are provided to further promote bone ingrowth. Fusion by bone ingrowth has been found to provide a more permanent, rigid connection between the implant **10** and the skeletal structure than provided by other known connection means.

The second element **22** of the implant **10** comprises a second connection means for engaging the second vertebra **14**. The second connection means preferably comprises a second fusion chamber **34**, substantially similar in construction to the above-described first fusion chamber **30**, and comprising at least one opening **36** formed therein for facilitating bone growth into, through and around the second fusion chamber **34** from the second vertebra **14**. Alternatively, the second connection means can comprise an adhesive connection, screw connection, pin connection, or any other effective alternative connection means. However, the provision of a second fusion chamber **30** is preferred, as it provides a more permanent and secure coupling than other known attachment means. Although the first element **20** and first vertebra **12** are depicted in the figures as above the second element **22** and second vertebra **14**, it will be understood that the present invention equally comprehends the reverse configuration wherein the first element, as described herein, is attached to a first vertebra lower on the spinal column than the second vertebra to which is attached the second element. The first and second elements can be fabricated from biocompatible materials including, without limitation, titanium, surgical

alloys, stainless steel, chrome-molybdenum alloy, cobalt chromium alloy, zirconium oxide ceramic, nonabsorbable polymers and other anticipated biocompatible metallic or polymeric materials.

Referring now to Figs. 2-3, the articulation means **24** of the present invention preferably comprises a first articulation surface **40** provided on the first element **20**, and an abutting second articulation surface **42** provided on the second element **22**. The first and second articulation surfaces **40,42** are preferably fabricated from or coated with low-friction, wear and impact-resistant, biocompatible materials, such as, for example, titanium, stainless steel, surgical alloys, chrome molybdenum alloys, cobalt chromium alloy, zirconium oxide ceramic, non-absorbable polymers and other biocompatible metallic or polymeric materials. The articulation means **24** resists axial compression between the first and second elements **20, 22**, but allows relative pivotal movement therebetween. Thus, when implanted, as shown in Figure 4, the articulation means **24** resists axial compression between first and second vertebra **12, 14** along a support axis **44** extending generally along the spinal column, as shown, for example, in Figure 4, but permits pivotal movement between vertebrae. The term "pivotal," is intended to comprehend either or both of a rotational or twisting motion about the support axis **44** (for example, rotation between cervical vertebrae by turning the head to the right or left), and/or a tilting motion angularly inclined in any direction relative to the support axis **44** (for example, nodding the head forward or backward and/or tilting the head downward to the right or left).

Axial compression, as well as lateral translation normal to the support axis **44**, is resisted between the first and second vertebra **12, 14**, by providing the first internal articulation surface **40** with a void, such as a concave surface **46**, which receives a protuberance, such as a convex surface **48**, projecting from the second internal articulation surface **42**. This "ball-and-socket" arrangement allows relative rotation about the support axis **44** between the first and second vertebra **12, 14**. The articulation means **24** can be provided with one or more stops to limit the range of rotational movement allowed.

In addition to the "ball-and socket" arrangement for the articulating means **24** other configurations are possible. In an alternative embodiment, as shown in Figures 8 and 10, the articulating means comprises a rocker **100** and channel **101**. The second articulation surface **42** can comprise a substantially U-shaped channel **101** extending along the length of the second element **22**. The first articulation surface **40** comprises a correspondingly- shaped rocker **100** which can be, for example, hemielliptical in shape along the length of the first element **20**. Such an arrangement permits only a tilting motion in one plane. In an alternative to this embodiment, as shown in Figure 9, a second range of motion can be added to the articulating means **24** by

modifying the shape of the channel 102. The modified channel 102 can be, for example, substantially hour-glass in shape through the depth of the channel 102. The channel width at the channel's base 103 and mouth 104 are greater than the channel width at the channel's midpoint 105. The hour-glass shaped channel 102 permits a tilting motion along two perpendicular linear planes.

5 In an second alternative to this embodiment, as shown in Figures 11a and 11b, an alternative second range of motion can be added to the articulating means 24 by modifying the shape of the channel 106. The modified channel 106 can be, for example substantially hour-glass in shape through the length of the second element 22. The channel width at the channel's longitudinal midpoint 107 is less than the channel width at the channel leading end 108 and tail end 109. Those skilled in the art, having the benefit of the instant disclosure, will appreciate that the "hour-glass" shape as described herein includes various curves or straight edges so long as the width at, or near, the end points of the channel (or the top and bottom of the channel) is wider than the width at some point between the end points. The hour-glass shaped channel 106 permits two ranges of motion, a tilting motion and a pivoting motion about the central axis. These motions may be desirable for some patients.

10 In an third alternative to this embodiment, as shown in Figures 15a and 15b, an alternative second range of motion can be added to the articulating means 24 by modifying the shape of the channel 110. The modified channel 110 can be, for example substantially diamond in shape through the length of the second element 22. The channel width at the channel's longitudinal midpoint 111 is greater than the channel width at the channel leading end 112 and tail end 113. Additionally, the first articulation surface 40 comprises a correspondingly- shaped rocker 113 which can be, for example, diamond in shape along the length of the first element 20. Those skilled in the art, having the benefit of the instant disclosure, will appreciate that the "diamond" shape as described herein includes various curves or straight edges so long as the width at some point between the end points of the channel (or the top and bottom of the channel) is wider than the width at, or near, the end points. The diamond shaped channel 110 permits three ranges of motion, a tilting motion and a pivoting motion about the central axis. These motions may be desirable for some patients.

20 The articulation means 24 preferably further comprises one or more angularly offset bevels 50 formed in the first internal articulation surface 40 and/or the second internal articulation surface 42, to allow relative tilting movement between the first and second vertebra 12, 14 in one or more directions. According to the embodiment shown in the figures, the first and second internal articulation surfaces 40,42 are each provided with an angularly offset bevel

50, in a generally pyramidal configuration, as seen best in Figure 9, thereby enabling tilting movement in all directions (360°). A generally conical configuration is also possible and, likewise, would permit both rotational movement and 360° tilting movement. Additionally, as shown in Figures 10 and 11, the first and second articulating surfaces 40, 42 can each be provided with a general arc configuration, which provide a greater range of motion.

5 The natural range of motion of the spine may be approximated by providing bevels 50 of approximately 5° around the periphery of each of the first and second articulation surfaces 40,42, thereby allowing approximately 10° of tilt in all directions between adjacent vertebrae. As depicted in the figures, the pivot point or axis of the articulation means 24 is generally centrally located on the first and second articulation surfaces 40, 42, and will be aligned with the spine's normal axis of rotation when implanted as shown in Figure 4. This location, however, can be selectively varied to position the center of rotation of the articulation means 24 centrally, anteriorly, posteriorly, to the left, to the right, or eccentrically (off-center in both the anterior/posterior direction and the left/right direction) of the spine's normal axis of rotation, in order to achieve proper alignment of the spine, thereby restoring optimal sagittal and coronal spinal balance and alignment.

10 In one embodiment as shown best by Figure 1, the first and second elements 20, 22 of the implant 10 of the present invention preferably comprise generally hemicylindrical outer walls 60, 70 adjoining to form a generally cylindrical body. When in their assembled configuration, the first element 20 and the second element 22 abut one another with their respective first and second articulating surfaces 40,42 adjacent and engaging one another, as described above. The first element 20 preferably further comprises a first radiused outer wall 60. The one or more openings 32 for facilitating bone ingrowth are provided in this first radiused outer wall 60, and communicate with a first fusion chamber 62 formed between the first radiused outer wall 60 and the first articulating surface 40. Similarly, the second element 22 preferably comprises a second radiused outer wall 70, defining one or more openings 36 for facilitating bone ingrowth. The openings 36 communicate with a second fusion chamber 72 formed between the second radiused outer wall 70 and the second articulating surface 34. The first and second radiused outer walls 60,70 can be provided with threads 80 to facilitate advancing the implant 10 into the intervertebral space during implantation and to help secure the implant 10 in position once implanted. The threads 80 on each of the first and second radiused outer walls 60, 70 are preferably aligned to form continuous threads when the first and second elements 20, 22 are engaged. In some instances, it may be desirable to provide self-tapping threads 80, and/or to configure the threads 80 to direct bone fragments generated by implantation

into the openings **32**, as taught by U.S. Patent No. 5,489,308 to Kuslich *et al.* In other less preferred embodiments, the threads **80** can be replaced with a contoured outer surface comprising smooth, splined, flanged, spiked or beaded surface features. The implant **10** can further comprise one or more support flanges **85** in the first and/or second elements **20, 22**, for additional strength.

5 In a second embodiment as shown best by Figures 6a, 6b and 12, the first and second elements **20,22** of the implant **10** of the present invention preferably comprise generally hemielliptical outer walls **97, 99** adjoining to form a generally elliptical body. When in their assembled configuration, the first element **20** and the second element **22** abut one another with their respective first and second articulating surfaces **40,42** adjacent and engaging one another, as described above. The first element **20** preferably further comprises a first radiused outer wall **97**. The one or more openings **32** for facilitating bone ingrowth are provided in this first radiused outer wall **97**, and communicate with a first fusion chamber **62** formed between the first radiused outer wall **97** and the first articulating surface **40**. Similarly, the second element **22** preferably comprises a second radiused outer wall **99**, defining one or more openings **36** for facilitating bone ingrowth. The openings **36** communicate with a second fusion chamber **72** formed between the second radiused outer wall **99** and the second articulating surface **42**. In alternative embodiments the contoured outer surfaces of the first **20** and **22** second elements can comprise smooth, splined, flanged, spiked or beaded surface features to secure the element in position once implanted. The implant **10** can further comprise one or more support flanges **85** in the first and/or second elements **20, 22**, for additional strength.

10 In a another embodiment, as shown in Figures 7 and 12, the element **10** may be tapered along the horizontal axis. The tailing end **92** having a vertical radius greater than the vertical radius of the leading end **93**. The tapered shape decreases the amount of material required to be removed and increases the ease of insertion of the implant **10** in between the first and second vertebra.

15 In a further preferred embodiment, the present invention may further comprise the provision of one or more stabilizing means for temporarily rigidly coupling the first element **20** to the second element **22** to prevent relative movement therebetween. For example, it is preferred that the first and second elements **20, 22** be held rigidly in place during installation of the implant **10** into the intervertebral space. In addition, the first and second elements **20, 22** should remain rigidly coupled for a sufficient length of time after implantation to permit sufficient bone ingrowth into the fusion chambers to prevent relative motion between the implant **10** and the vertebrae **12, 14** during normal activities of the patient. Typically, approximately

eight to twenty weeks of bone ingrowth will be sufficient, before the first and second elements **20**, **22** are uncoupled and permitted to articulate relative to one another. This temporary stabilization of the first and second elements is accomplished by the present invention, without the requirement of a second surgical procedure, through the use of medium-term stabilizing means formed from bioreabsorbable material. Examples of bioreabsorbable materials include polyglycolate polymers or analogues, lactides, polydioxanone, polyglyconate, lactide/glycolide copolymers. By appropriate selection of the material(s) of construction, the length of time required to biodegrade the stabilizing means can be effectively controlled. After the stabilizing means are dissolved and absorbed by the body, the first and second elements of the implant **10** are uncoupled, allowing articulation. In one example embodiment, depicted in Figure 3, the stabilizing means can comprise one or more biodegradable shims **82** wedged between the first element **20** and the second element **22**, to prevent relative motion therebetween. In another example embodiment, the first and second elements **20**, **22** are placed in their coupled configuration, as shown in Figs. 2-3, with the spaces between the articulating surfaces **40**, **42** then being injected or filled with a biodegradable polymer, which provides the medium term temporary stabilizing means to couple the elements in position. Care will be taken to avoid filling the fusion chambers **30**, **34** and the openings **32**, **36** to the fusion chambers with the polymer, which could inhibit bone ingrowth. The threads **82** will also remain exposed to assist in implantation of the device. In another example embodiment, depicted in Figure 2, the stabilizing means comprise a removable and/or bioreabsorbable endcap **90**, which releasably engages the tailing end **92** of the implant **10** to couple the first and second elements **20**, **22**. The endcap can comprise one or more clips **94** for engaging the implant **10**, and one or more keyways **96** for engaging a wrench, driver or other actuation device used to advance the implant **10** into the intervertebral space. A second removable and/or absorbable endcap can be installed on the leading end **93** of the implant **10**. The endcaps may additionally function to retain the bone fragments within the chambers **62**, **72** of the fusion chambers **30**, **34**, as will be described in greater detail below, until sufficient bone ingrowth and fusion has occurred.

Another embodiment of the present invention is depicted by Figure 5, which shows an implant **10**, generally comprising first and second elements **20**, **22**, substantially as described above, and further comprising an intermediate articulation element, which in the depicted embodiment comprises a generally hemispherical bowl-shaped cap **90** interposed between the concave surface **46** of the first element **20** and the convex surface **48** of the second element **22**. The cap **90** is preferably fabricated from a wear-resistant, low friction material of construction, which may be somewhat resilient to absorb impact loading. The provision of the cap **90** allows

articulation at the interface between the top surface of the cap and the concave surface **46** of the first element **20**, and between the bottom surface of the cap and the convex surface **48** of the second element **22**, resulting in a bipolar articulation. This arrangement reduces frictional wear on the articulation surfaces by distributing wear over two articulation interfaces. The engagement of the concave lower surface of the cap **90** with the convex surface **48** of the second element **22**, and the engagement of the convex upper surface of the cap **90** with the concave surface **46** of the first element **20**, prevents the cap **90** from becoming dislodged when the implant **10** is installed.

The present invention further comprises a method of maintaining a desired intervertebral space between a first vertebra **12** and a second vertebra **14**. The method preferably comprises removing a section of the first vertebra to form a cavity therein, mounting a first element of an articulating spinal implant into the cavity, and connecting a second element of the implant to the second vertebra. The articulating spinal implant used to carry out this method is preferably substantially similar to the example embodiment described above, having first and second internal articulation surfaces which adjoin to form a joint allowing relative pivotal movement between the first and second elements, but preventing relative axial compression therebetween. At least one of the elements preferably further comprises a fusion chamber, including a chamber and at least one opening communicating with the chamber, for facilitating bone ingrowth into, through and around the fusion chamber from the respective vertebra. In a preferred form, the method of the present invention comprises attachment of both the first and second elements of the implant to the respective vertebra using fusion chambers for bone ingrowth. In this embodiment, a section of the second vertebra is preferably removed to form a cavity therein for receiving the second element of the implant. The method of the present invention can further comprise the insertion of bone fragments, which may be the fragments formed in the above-described removal of vertebral sections, into the fusion chamber(s) of the implant. The presence of these bone fragments has been shown to stimulate and enhance bone ingrowth into the fusion chamber. In another embodiment, the method of the present invention anticipates the application of means for stimulating bone growth into, through, and/or around the fusion chamber(s). The means for stimulating bone growth can comprise, for example, electrical or magnetic bone growth stimulators, bone morphogenetic protein (BMP), hydroxyl apatite compounds, demineralized bone compound, and/or other bone growth stimulating devices or compounds. It is also anticipated that the introduction of a cyanoacrylate material, commonly referred to as surgical glue, onto the outer surface of the fusion chamber(s) may be used to fix the implant in optimal position awaiting bone ingrowth.

Implantation of the articulating spinal implant according to the present invention may be carried out in a manner generally similar to previously-known methods for the implantation of non-articulating, rigid-fusion implants, with exceptions as set out herein. For example, the method of the present invention may utilize standard surgical approaches to the spine from either an anterior approach for the cervical and thoracic spinal segments, or from an anterior or posterior lateral approach to the lumbar spinal segments. The removal of vertebral sections may be accomplished by drilling or chipping a generally circular bore having a diameter and depth adapted to generally match the implant to be utilized, bridging the first and second vertebra. Additionally, the circular bore may be tapered with the leading end diameter being smaller than the tail end diameter. The bore is preferably centered over the intervertebral space, approximately midway between the first and second vertebra. Threads may then be tapped into the bore to facilitate insertion of the implant.

In an alternative method, the removal of vertebral sections may be accomplished by using a unique surgical instrument, as shown in Figure 14, for drilling an elliptical bore having a major and minor diameter and depth adapted to generally match the implant to be utilized, bridging the first and second vertebra. Preferably, the surgical instrument is affixed to a drill to provide rotational power to the cutting portion. The cutting portion of the surgical instrument consists of a circular flute drill bit sheathed within cutting blades formed in an elliptical shape. The flute drill bit extends out beyond cutting blades to cut a circular section between the first and second vertebra. As the drill bit cuts into the vertebra the cutting blades then remove the remaining material to form an elliptical bore having a major and minor diameter and depth adapted to generally match the implant to be utilized, bridging the first and second vertebra.

Alternatively, the implant can be provided with self-tapping threads. The implant is assembled with the first and second articulating surfaces engaged, and the first and second elements of the implant are rigidly coupled by stabilizing means substantially as described above. The stabilized implant is advanced into the bore to the desired depth. Preferably, the implant is advanced until the tailing end **92** is flush or slightly recessed relative to the outer surface of the vertebrae, thereby eliminating the possibility that outwardly projecting portions of the implant may interfere with or injure adjacent or regional vascular, neural or visceral structures.

In the lumbar area, where greater load bearing is required, two articulating implants can be placed in parallel positions with the lengthwise axis of each adjacent one to the other, in a generally parallel arrangement, allowing flexion/extension movement alone. This arrangement will typically require removal of vertebral material to form two openings, or an extended

opening to accommodate both implants. Alternatively, a single, appropriately sized implant could be placed in the interspace utilizing the transabdominal open surgical approach, the transabdominal laparoscopic approach, or the retroperitoneal open anterior approach allowing pivotal motion around the single point of articulation as described above for use in cervical and thoracic intervertebral disc spaces.

5 Post-operatively, bone ingrowth will occur, fusing the first and/or second elements of the implant to the respective vertebra. After sufficient passage of time, the stabilizing means is dissolved and absorbed into the body, uncoupling the articulation means to permit relative motion between the first and second elements, thus preserving spinal flexibility and minimizing destructive stress upon adjacent intervertebral joints. The implant resists axial compression
10 between the first and second elements, and thereby prevents relative compression between the first and second vertebra, thus maintaining the desired intervertebral space. Further, the implant is recessed into the recipient vertebral site, eliminating impingement on next adjacent vascular, neural or visceral structures.

15 While the invention has been disclosed in its preferred forms, it will be apparent to those skilled in the art that many modifications, additions, and deletions can be made therein without departing from the spirit and scope of the invention and its equivalents as set forth in the following claims.

Claims

1. A spinal implant comprising:

- 1 (a) a first element comprising a first articulating surface, a first outer surface, and
2 a first connection means for engaging a first vertebra;
- 3 (b) a second element comprising a second articulating surface, a second outer
4 surface, and a second connection means for engaging a second vertebra;
- 5 (c) a tail wall and a leading wall; and
- 6 (d) an articulation means, coupling said first articulating surface to said second
7 articulating surface, for allowing relative movement between said first element
8 and said second element, wherein said articulating means resist axial
9 compression in the direction of said support axis.

1 2. The spinal implant of claim 1, wherein said first articulation surface abuts said
2 second articulation surface to form said articulation means.

1 3. The spinal implant of claim 2, wherein said articulation means comprises a concave
2 surface in said first element and a convex surface from said second element, wherein at least a
3 portion of said convex surface is engaged within said concave surface.

1 4. The spinal implant of claim 2, wherein said articulation means comprises a channel
2 along the length of said second element and a rocker along the length of said first element,
3 wherein at least a portion of said rocker is engaged within said channel.

1 5. The spinal implant of claim 4, wherein said channel along the length of said second
2 element has a width at the top and bottom of said channel which is greater than the width at
3 some point, between said top and said bottom.

1 6. The spinal implant of claim 4, wherein said channel along the length of said second
2 element has a channel width at each end which is greater than the channel width at some point
3 between each end.

1 7. The spinal implant of claim 4, wherein said channel along the length of said second
2 element has a channel width at each end which is less than the channel width at some point
3 between each end.

1 8. The spinal implant of claim 7, wherein said rocker along the length of said first
2 element has a rocker width at each end which is less than the rocker width at some point between
3 each end.

1 9. The spinal implant of claim 1, wherein said first connection means comprises a first
2 fusion chamber located between said first articulation surface and said first outer surface, and
3 said first outer surface comprises at least one opening for facilitating bone ingrowth into said
4 first fusion chamber.

1 10. The spinal implant of claim 1, wherein said second connection means comprises a
2 second fusion chamber located between said second articulation surface and said second outer
3 surface, and said second outer surface comprise at least one opening for facilitating bone
4 ingrowth into said second fusion chamber.

1 11. The spinal implant of claim 1, wherein said first outer surface comprises a first
2 radiused outer wall, and said second outer surface comprises a second radiused outer wall.

1 12. The spinal implant of claim 11, wherein said first radiused outer wall and said
2 second radiused outer wall comprise a securing means for securing said spinal implant within
3 a cavity between said first vertebra and said second vertebra.

1 13. The spinal implant of claim 12, wherein said securing means comprises a threaded
2 surface on said first and second radiused outer surface.

1 14. The spinal implant of claim 11, wherein said first radiused outer wall and said
2 second radiused outer wall comprise a hemicylindrical outer surface.

1 15. The spinal implant of claim 11, wherein said first radiused outer wall and said
2 second radiused outer wall comprise a hemielliptical outer surface.

1 16. The spinal implant of claim 1, wherein a first vertical radius of said tail wall is
2 greater then a second vertical radius of said end wall.

1 17. The spinal implant of claim 1, further comprising a stabilizing means for
2 temporarily rigidly coupling said first element to said second element.

1 18. The spinal implant of claim 17, wherein said stabilizing means comprises an endcap
2 adapted to releasably engage a portion of said first element and a portion of said second element.

1 19. The spinal implant of claim 17, wherein said stabilizing means comprises at least
2 one bioreabsorbable element adapted to be absorbed after implantation.

1 20. The spinal implant of claim 1, wherein a intermediate articulation element is
2 positioned between said first and second articulation surfaces.

1 21. The spinal implant of claim 20, wherein said first articulation surface comprises a
2 concave surface, and said second articulation surface comprises a convex surface, and said
3 intermediate articulation element comprises a generally hemispherical cap.

1 22. A method of maintaining an intervertebral space between a first vertebra and a
2 second vertebra, said method comprising the steps of

- 3 (a) removing a section of the first vertebra to form a cavity therein;
- 4 (b) mounting a first element of a spinal implant within the cavity formed in the first
5 vertebra, said first element comprising a first articulation surface and a first
6 fusion chamber having at least one opening therein for facilitating bone
7 ingrowth;
- 8 (c) connecting a second element of the spinal implant to said second vertebra, said
9 second element comprising a second articulation surface, wherein said first and
10 second articulation surfaces adjoin to form a joint allowing relative pivotal
11 movement between said first and second elements but preventing relative
12 compression between said first and second elements.

1 23. The method of claim 22, further comprising inserting at least a portion of said
2 removed section of said first vertebra into the external fusion chamber.

3 24. The method of claim 23, wherein said second element further comprises a second
4 fusion chamber having at least one opening therein for facilitating bone ingrowth, and wherein
5 said method further comprises removing a section of said second vertebra to form a cavity
6 therein, and mounting said second element of the spinal implant within said cavity formed in
7 said second vertebra.

1 25. The method of claim 24, further comprising applying means for stimulating bone
2 growth to each of said first and second fusion chambers.

1 26. The method of claim 22, further comprising temporarily rigidly coupling said first
2 element to said second element with at least one bioreabsorbable stabilizing means prior to
3 mounting said first element within said cavity in said first vertebra.

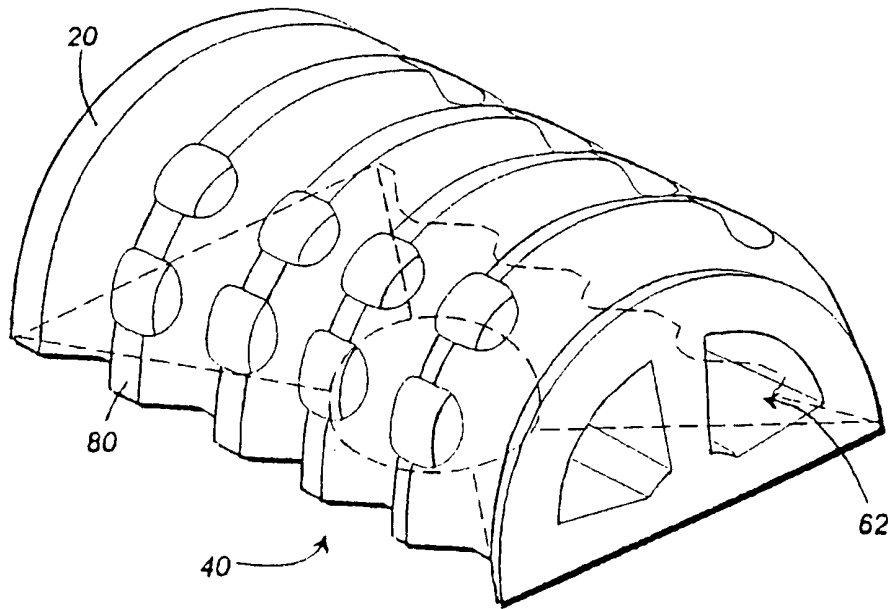

FIG. 1A

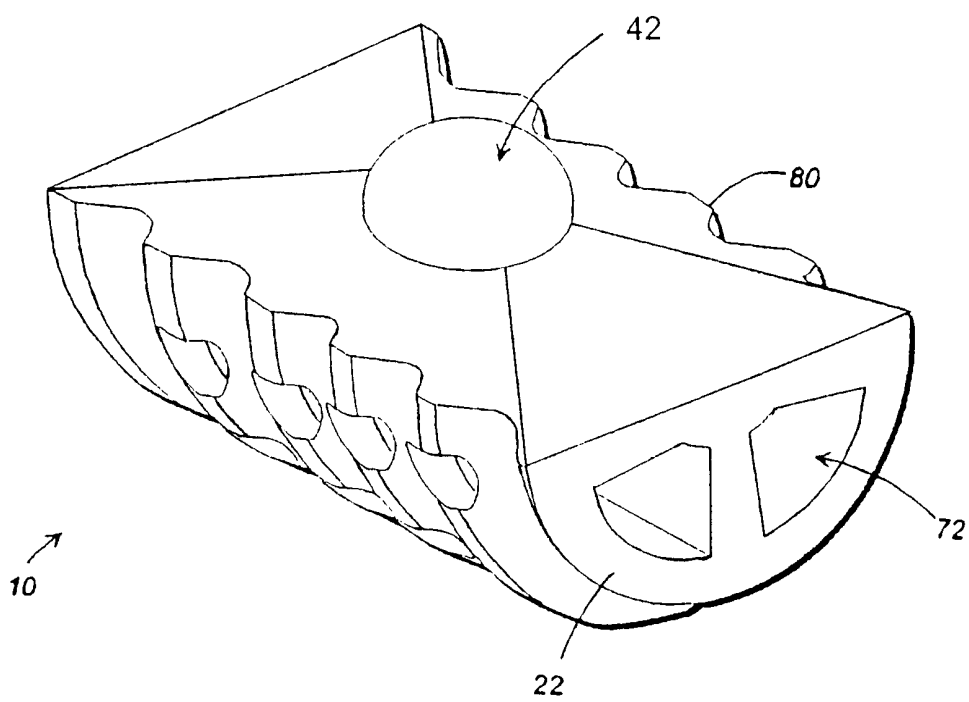

FIG. 1B

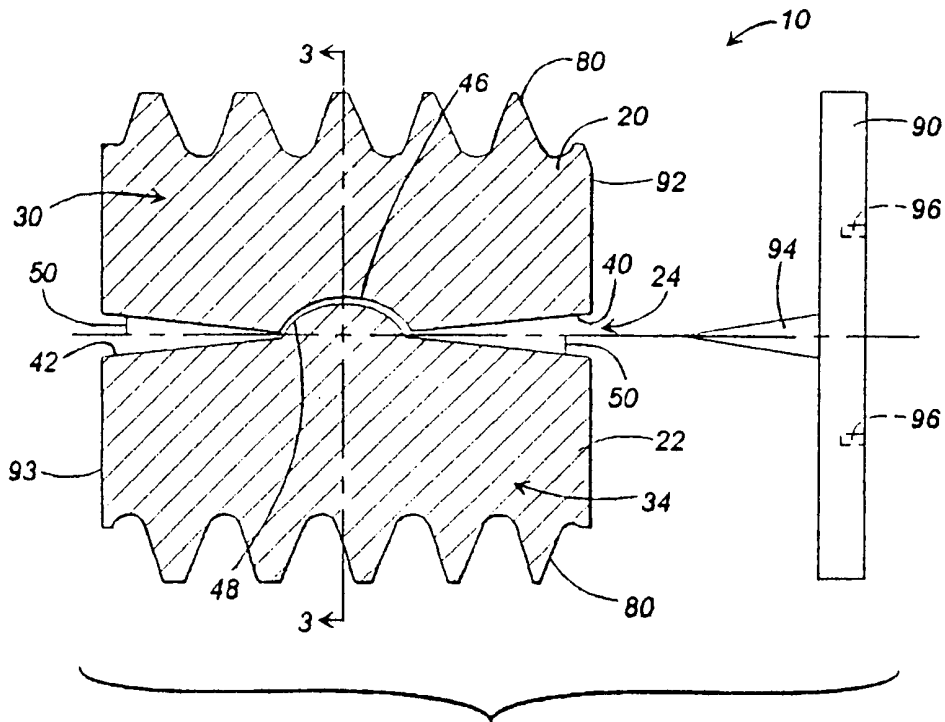

FIG. 2

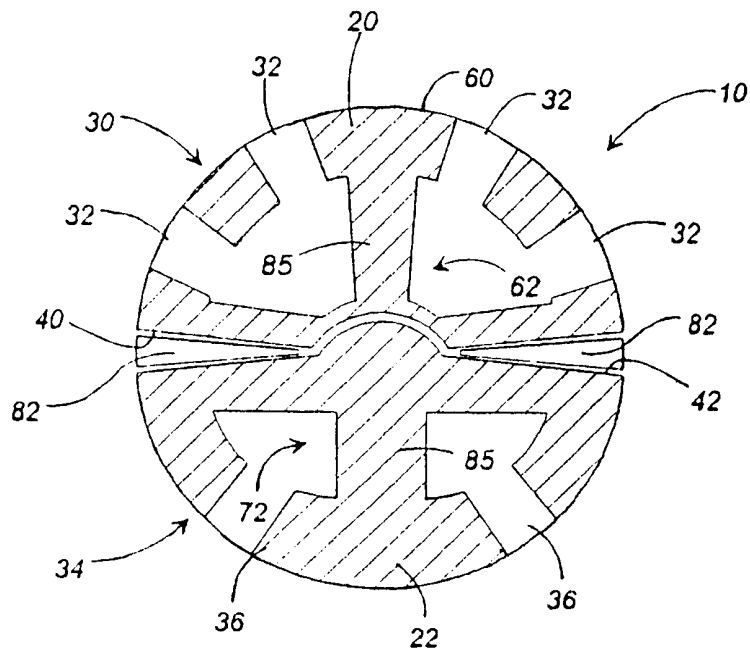

FIG. 3

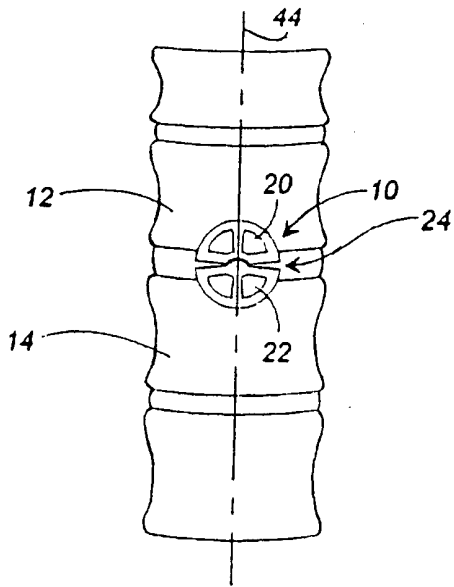

FIG. 4A

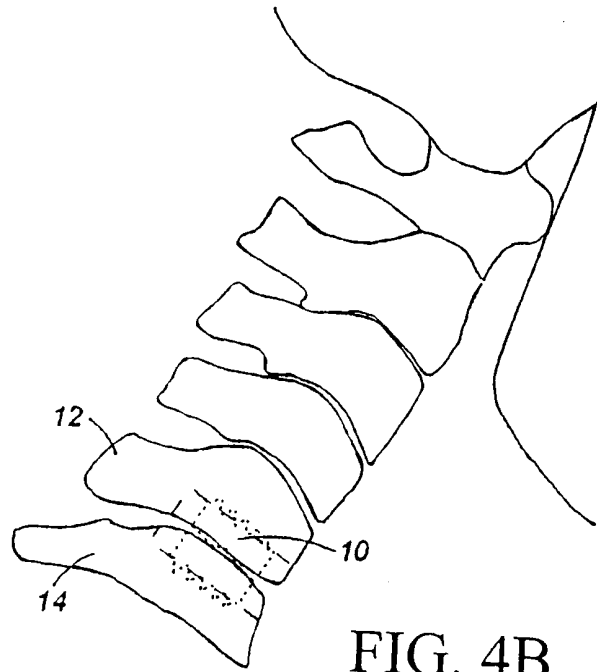

FIG. 4B

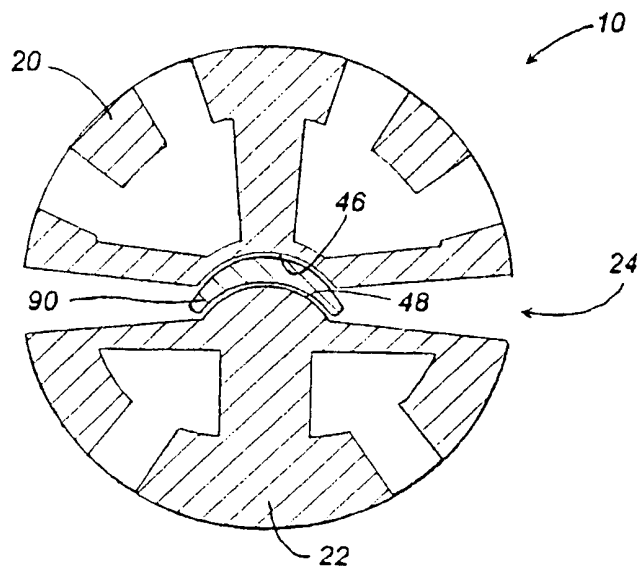

FIG. 5

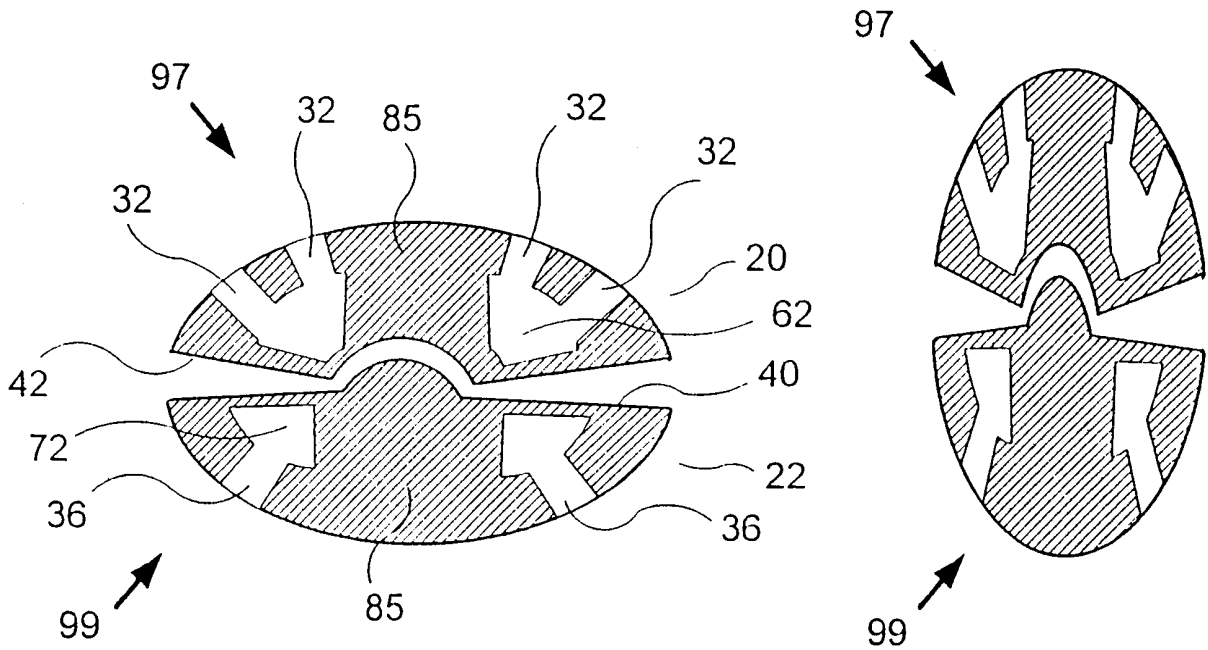

FIG. 6A

FIG. 6B

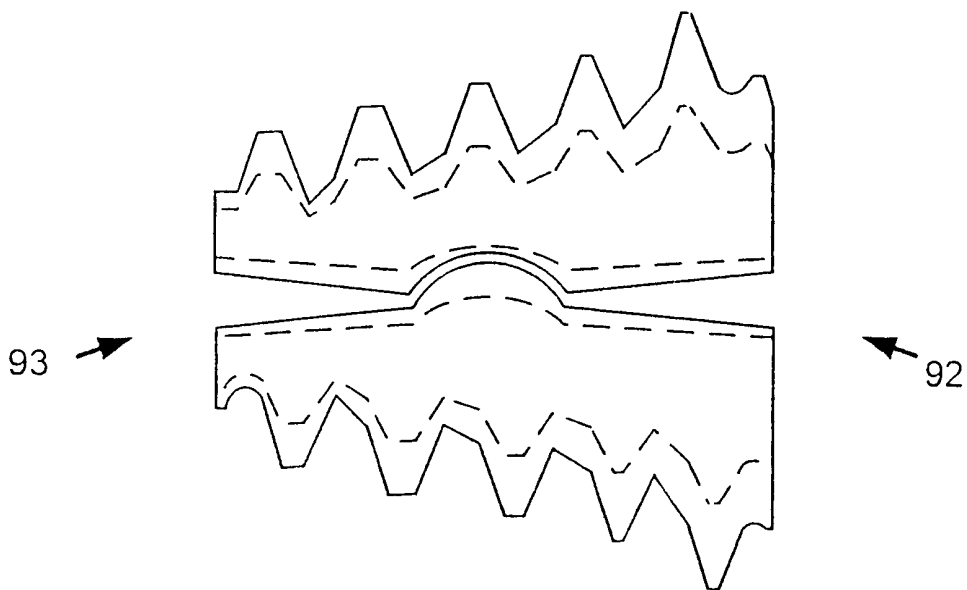

FIG. 7

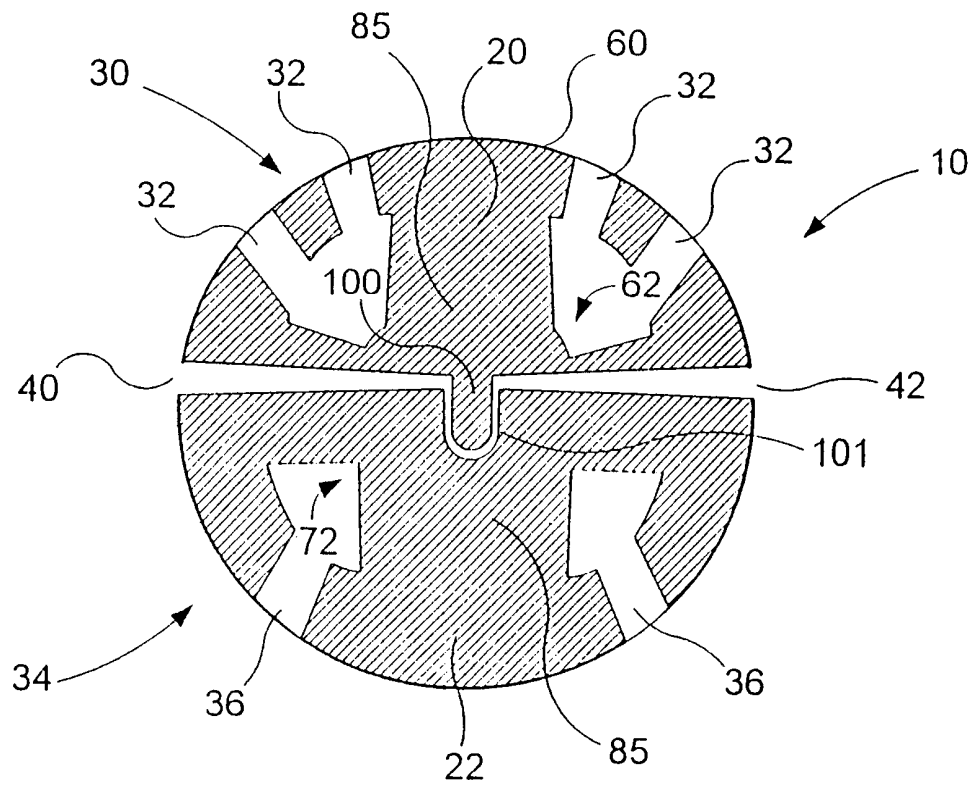

FIG. 8

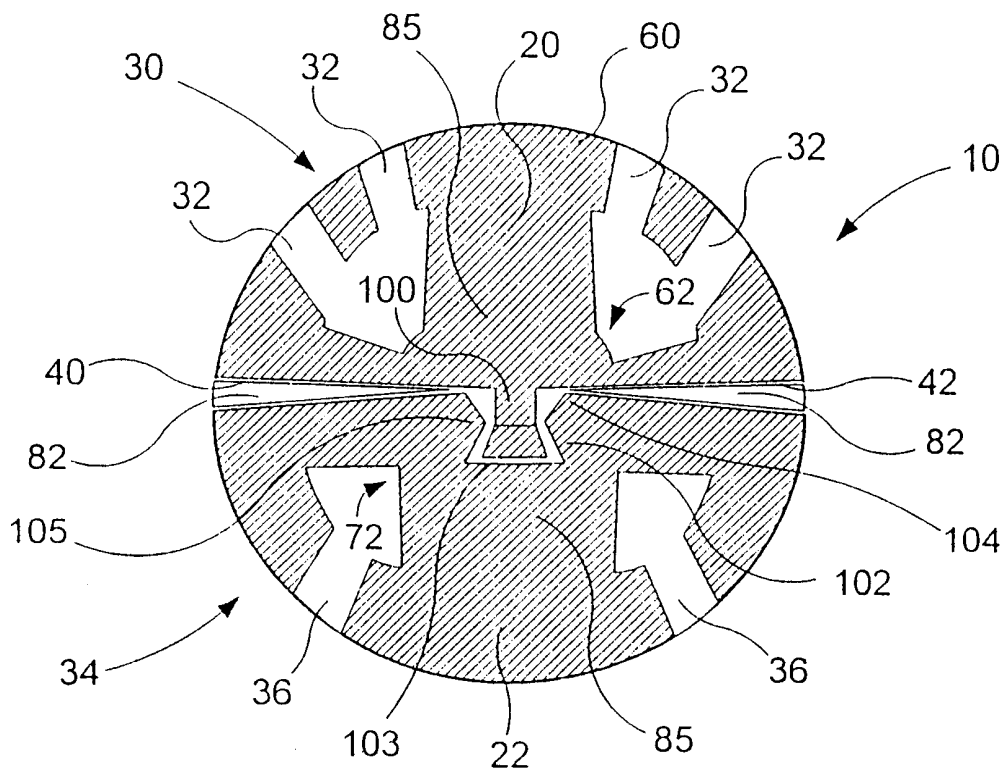
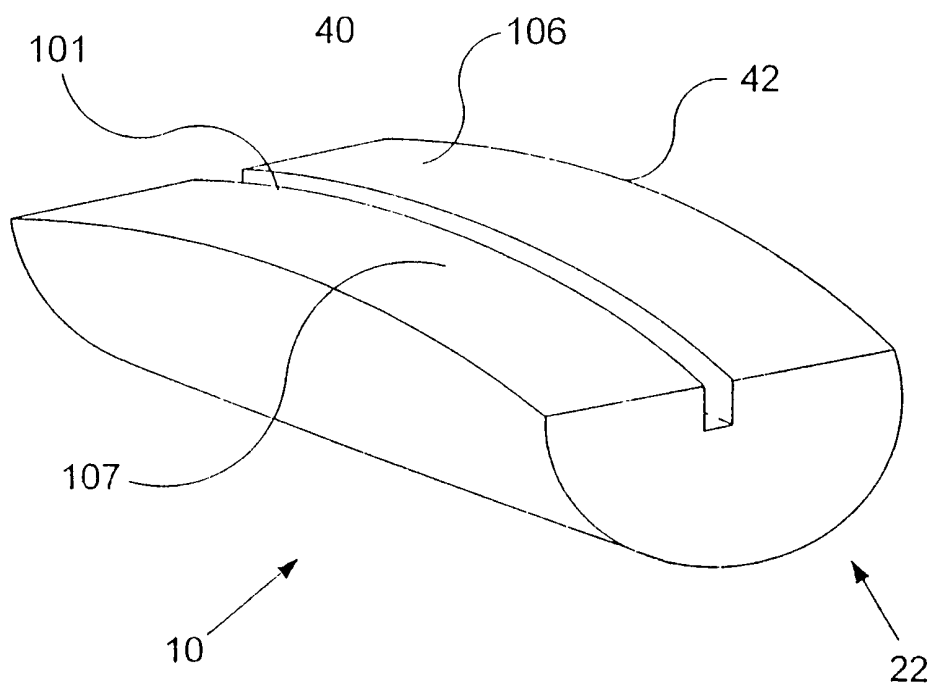
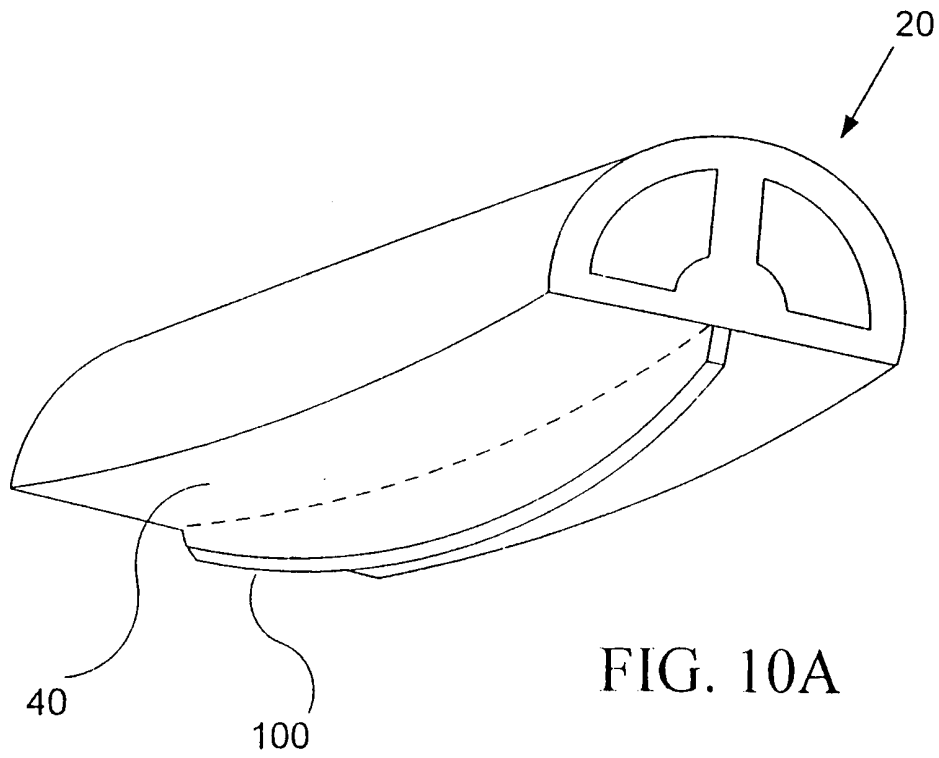

FIG. 9



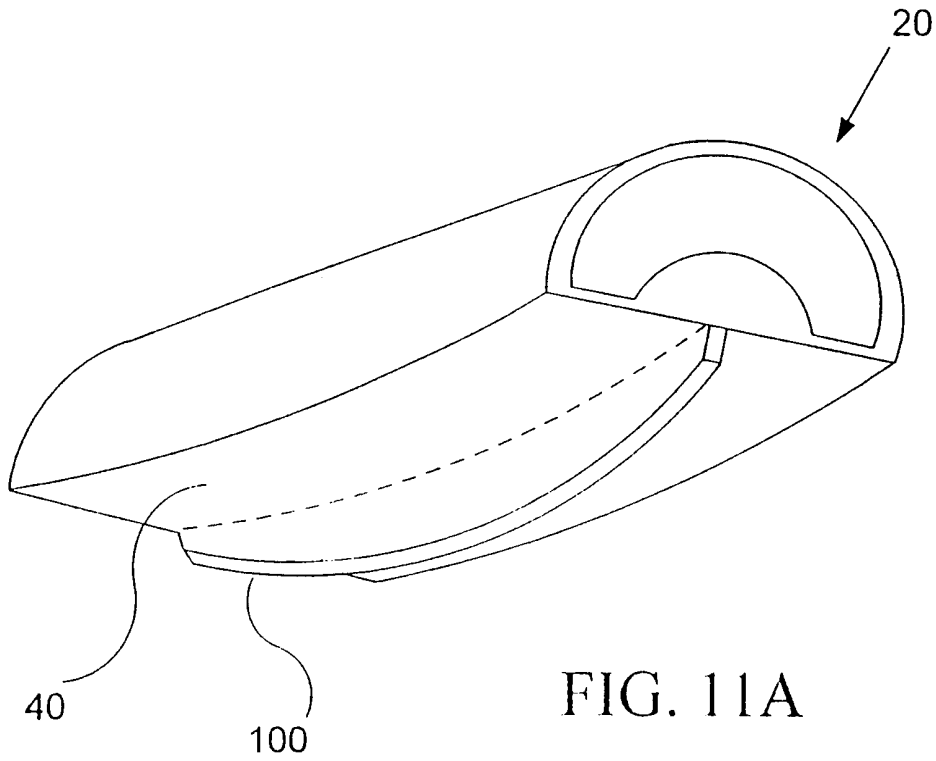

FIG. 11A

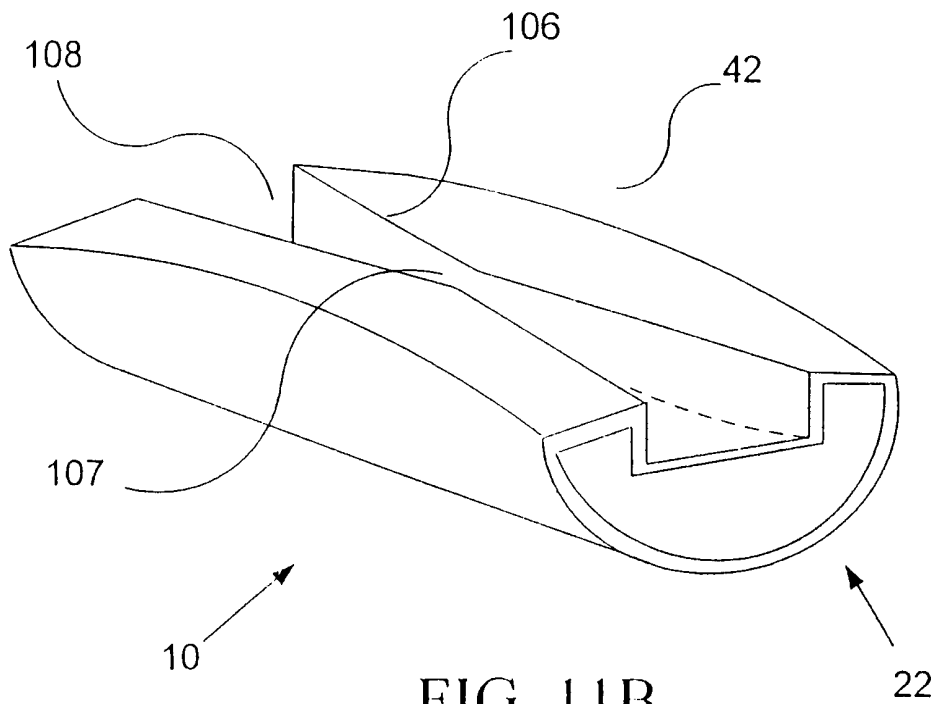

FIG. 11B

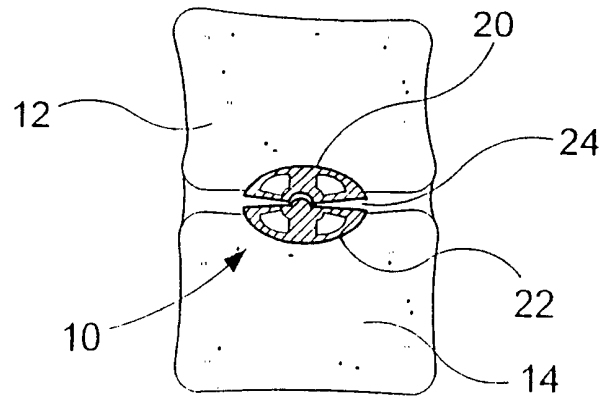

FIG. 12

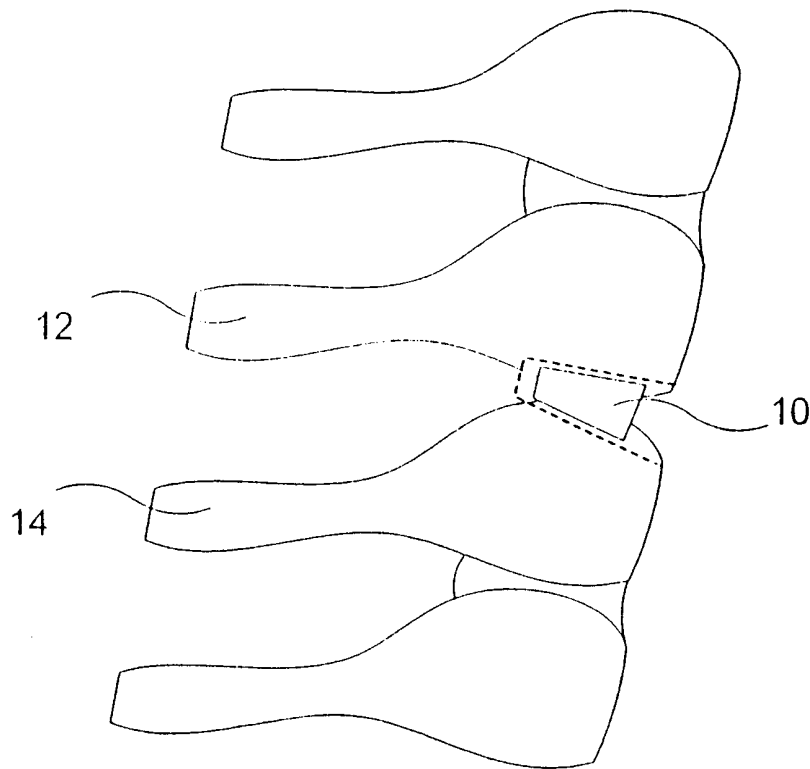

FIG. 13

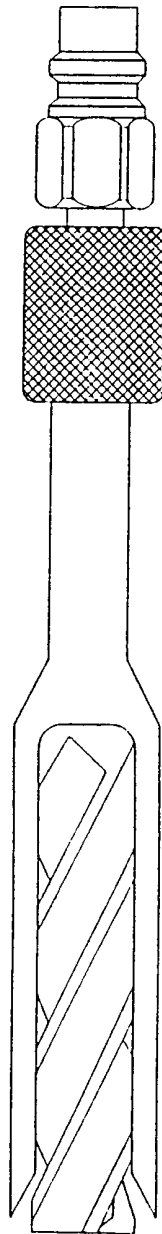

FIG. 14A



FIG. 14B

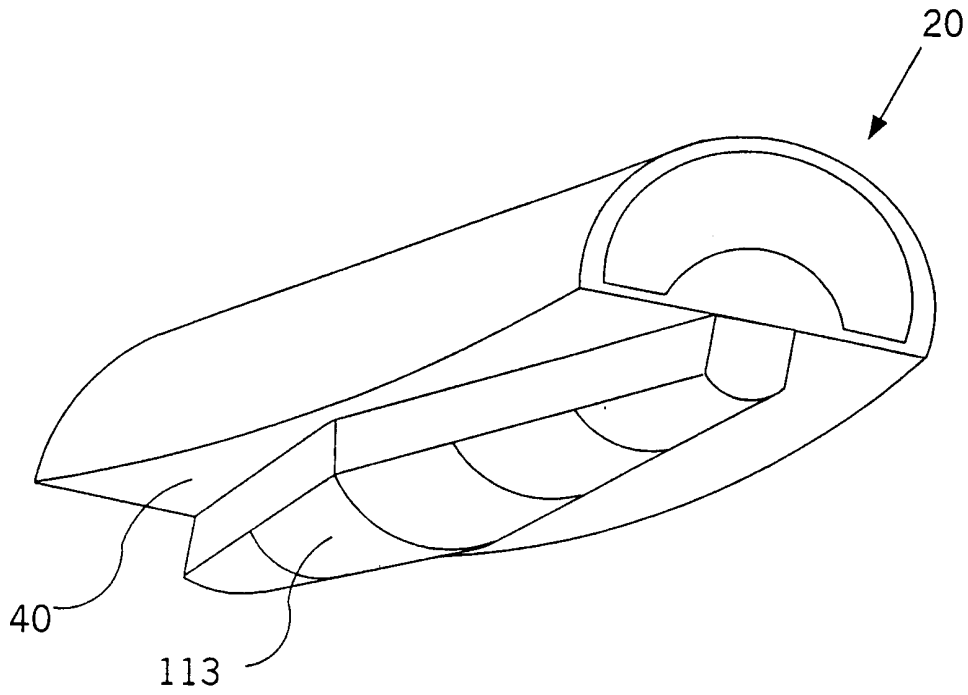

FIG. 15A

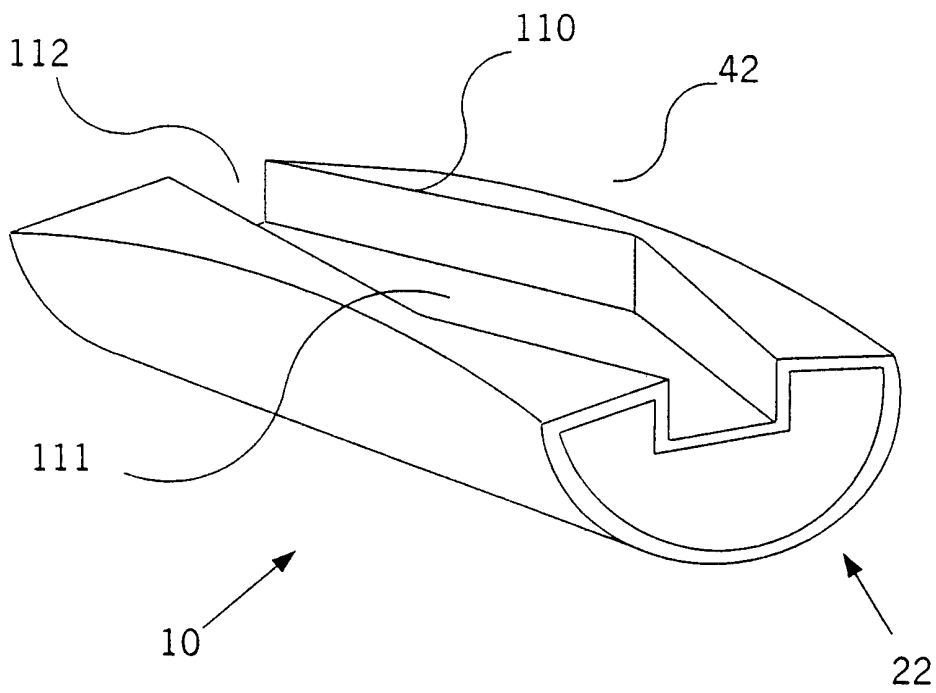

FIG. 15B

INTERNATIONAL SEARCH REPORT

Inte. .onal Application No
PCT/US 00/22939

A. CLASSIFICATION OF SUBJECT MATTER IPC 7 A61F2/44				
According to International Patent Classification (IPC) or to both national classification and IPC				
B. FIELDS SEARCHED				
Minimum documentation searched (classification system followed by classification symbols) IPC 7 A61F				
Documentation searched other than minimum documentation to the extent that such documents are included in the fields searched				
Electronic data base consulted during the international search (name of data base and, where practical, search terms used) EPO-Internal				
C. DOCUMENTS CONSIDERED TO BE RELEVANT				
Category °	Citation of document, with indication, where appropriate, of the relevant passages	Relevant to claim No.		
P, X	WO 99 53871 A (CAUTHEN RESEARCH GROUP INC) 28 October 1999 (1999-10-28) the whole document ---	1-6, 9-21		
X	EP 0 042 271 A (KUNTZ DAVID J) 23 December 1981 (1981-12-23) claim 8; figures 12-14 ---	1-3, 11, 12, 14, 15 13, 16		
Y	---	---		
X	WO 98 14142 A (SURGICAL DYNAMICS INC) 9 April 1998 (1998-04-09)	1-3, 9, 10		
Y	page 12, line 15 -page 14, line 7; figures 13-15 ---	17, 19		
X	WO 93 10725 A (CUSTOMFLEX LIMITED) 10 June 1993 (1993-06-10) claims 1-9; figure 1 ---	1-3, 20		
--- -/--				
<input checked="" type="checkbox"/> Further documents are listed in the continuation of box C. <input checked="" type="checkbox"/> Patent family members are listed in annex.				
° Special categories of cited documents :				
<table style="width: 100%; border: none;"> <tr> <td style="width: 50%; border: none; vertical-align: top;"> <ul style="list-style-type: none"> *A* document defining the general state of the art which is not considered to be of particular relevance *E* earlier document but published on or after the international filing date *L* document which may throw doubts on priority claim(s) or which is cited to establish the publication date of another citation or other special reason (as specified) *O* document referring to an oral disclosure, use, exhibition or other means *P* document published prior to the international filing date but later than the priority date claimed </td> <td style="width: 50%; border: none; vertical-align: top;"> <ul style="list-style-type: none"> *T* later document published after the international filing date or priority date and not in conflict with the application but cited to understand the principle or theory underlying the invention *X* document of particular relevance; the claimed invention cannot be considered novel or cannot be considered to involve an inventive step when the document is taken alone *Y* document of particular relevance; the claimed invention cannot be considered to involve an inventive step when the document is combined with one or more other such documents, such combination being obvious to a person skilled in the art. *&* document member of the same patent family </td> </tr> </table>			<ul style="list-style-type: none"> *A* document defining the general state of the art which is not considered to be of particular relevance *E* earlier document but published on or after the international filing date *L* document which may throw doubts on priority claim(s) or which is cited to establish the publication date of another citation or other special reason (as specified) *O* document referring to an oral disclosure, use, exhibition or other means *P* document published prior to the international filing date but later than the priority date claimed 	<ul style="list-style-type: none"> *T* later document published after the international filing date or priority date and not in conflict with the application but cited to understand the principle or theory underlying the invention *X* document of particular relevance; the claimed invention cannot be considered novel or cannot be considered to involve an inventive step when the document is taken alone *Y* document of particular relevance; the claimed invention cannot be considered to involve an inventive step when the document is combined with one or more other such documents, such combination being obvious to a person skilled in the art. *&* document member of the same patent family
<ul style="list-style-type: none"> *A* document defining the general state of the art which is not considered to be of particular relevance *E* earlier document but published on or after the international filing date *L* document which may throw doubts on priority claim(s) or which is cited to establish the publication date of another citation or other special reason (as specified) *O* document referring to an oral disclosure, use, exhibition or other means *P* document published prior to the international filing date but later than the priority date claimed 	<ul style="list-style-type: none"> *T* later document published after the international filing date or priority date and not in conflict with the application but cited to understand the principle or theory underlying the invention *X* document of particular relevance; the claimed invention cannot be considered novel or cannot be considered to involve an inventive step when the document is taken alone *Y* document of particular relevance; the claimed invention cannot be considered to involve an inventive step when the document is combined with one or more other such documents, such combination being obvious to a person skilled in the art. *&* document member of the same patent family 			
Date of the actual completion of the international search <p style="text-align: center; font-weight: bold;">22 November 2000</p>		Date of mailing of the international search report <p style="text-align: center; font-weight: bold;">04/12/2000</p>		
Name and mailing address of the ISA European Patent Office, P.B. 5818 Patentlaan 2 NL - 2280 HV Rijswijk Tel. (+31-70) 340-2040, Tx. 31 651 epo nl, Fax: (+31-70) 340-3016		Authorized officer <p style="text-align: center; font-weight: bold;">Korth, C-F</p>		

INTERNATIONAL SEARCH REPORT

International Application No
PCT/US 00/22939

C.(Continuation) DOCUMENTS CONSIDERED TO BE RELEVANT		
Category °	Citation of document, with indication, where appropriate, of the relevant passages	Relevant to claim No.
Y	EP 0 716 840 A (SURGICAL DYNAMICS INC) 19 June 1996 (1996-06-19) abstract; figure 1 ---	13,16
Y	EP 0 640 326 A (SULZER MEDIZINALTECHNIK AG) 1 March 1995 (1995-03-01) claims 1-5,7; figures 1,2 ---	17,19
A	US 5 425 773 A (PETTINE KENNETH A ET AL) 20 June 1995 (1995-06-20) the whole document ---	7,8
A	US 5 593 445 A (WAITS C THOMAS) 14 January 1997 (1997-01-14) figure 9 -----	20,21

INTERNATIONAL SEARCH REPORT

Information on patent family members

International Application No

PCT/US 00/22939

Patent document cited in search report	Publication date	Patent family member(s)	Publication date
WO 9953871 A	28-10-1999	AU 3758799 A	08-11-1999
EP 0042271 A	23-12-1981	CA 1146301 A US 4349921 A AU 7169081 A BR 8103700 A DE 3165841 D JP 57029348 A MX 153795 A SU 1127522 A	17-05-1983 21-09-1982 17-12-1981 02-03-1982 11-10-1984 17-02-1982 12-01-1987 30-11-1984
WO 9814142 A	09-04-1998	US 5782832 A AU 4598797 A EP 1009336 A	21-07-1998 24-04-1998 21-06-2000
WO 9310725 A	10-06-1993	AU 2954192 A US 5507816 A	28-06-1993 16-04-1996
EP 0716840 A	19-06-1996	AU 3505395 A AU 708384 B AU 4035395 A CA 2164922 A CA 2199637 A EP 0781113 A JP 8215225 A US 6033405 A WO 9608205 A US 5885299 A US 5906616 A AU 696997 B JP 10508766 T	29-03-1996 05-08-1999 20-06-1996 12-06-1997 21-03-1996 02-07-1997 27-08-1996 07-03-2000 21-03-1996 23-03-1999 25-05-1999 24-09-1998 02-09-1998
EP 0640326 A	01-03-1995	AT 188605 T DE 59309928 D ES 2142340 T US 5735901 A US 5725590 A	15-01-2000 17-02-2000 16-04-2000 07-04-1998 10-03-1998
US 5425773 A	20-06-1995	US 5258031 A AU 7313394 A EP 0754018 A JP 10501705 T WO 9526697 A US 5562738 A ZA 9404507 A	02-11-1993 23-10-1995 22-01-1997 17-02-1998 12-10-1995 08-10-1996 14-02-1995
US 5593445 A	14-01-1997	NONE	