

(19) World Intellectual Property Organization  
International Bureau



(43) International Publication Date  
19 June 2008 (19.06.2008)

PCT

(10) International Publication Number  
**WO 2008/073472 A2**

(51) International Patent Classification:  
*H02J 13/00* (2006.01) *H04Q 9/00* (2006.01)  
*H01M 8/04* (2006.01)

(74) Agents: FARRELL, Mark et al; Lee & Hayes, PLLC,  
421 W Riverside Ave, Suite 500, Spokane, WA 99201  
(US).

(21) International Application Number:  
PCT/US2007/025436

(81) Designated States (unless otherwise indicated, for every kind of national protection available): AE, AG, AL, AM, AT, AU, AZ, BA, BB, BG, BH, BR, BW, BY, BZ, CA, CH, CN, CO, CR, CU, CZ, DE, DK, DM, DO, DZ, EC, EE, EG, ES, FI, GB, GD, GE, GH, GM, GT, HN, HR, HU, ID, IL, IN, IS, JP, KE, KG, KM, KN, KP, KR, KZ, LA, LC, LK, LR, LS, LT, LU, LY, MA, MD, ME, MG, MK, MN, MW, MX, MY, MZ, NA, NG, NI, NO, NZ, OM, PG, PH, PL, PT, RO, RS, RU, SC, SD, SE, SG, SK, SL, SM, SV, SY, TJ, TM, TN, TR, TT, TZ, UA, UG, US, UZ, VC, VN, ZA, ZM, ZW

(22) International Filing Date:  
11 December 2007 (11.12.2007)

(25) Filing Language: English

(26) Publication Language: English

(30) Priority Data:  
60/869,439 11 December 2006 (11.12.2006) US

(84) Designated States (unless otherwise indicated, for every kind of regional protection available): ARIPO (BW, GH, GM, KE, LS, MW, MZ, NA, SD, SL, SZ, TZ, UG, ZM, ZW), Eurasian (AM, AZ, BY, KG, KZ, MD, RU, TJ, TM), European (AT, BE, BG, CH, CY, CZ, DE, DK, EE, ES, FI, FR, GB, GR, HU, IE, IS, IT, LT, LU, LV, MC, MT, NL, PL, PT, RO, SE, SI, SK, TR), OAPI (BF, BJ, CF, CG, CI, CM, GA, GN, GQ, GW, ML, MR, NE, SN, TD, TG).

(71) Applicant (for all designated States except US):  
**V2GREEN, INC.** [US/US]; 1725 Westlake Ave N.,  
Seattle, WA 98109 (US).

(72) Inventors; and

(75) Inventors/Applicants (for US only): **BRIDGES, Seth, W.**  
[US/US]; 5432 Kirkwood Pl. N., Seattle, WA 98103 (US).  
**POLLACK, Seth, B.** [US/US]; 2920 Queen Ann Ave. N.,  
Seattle, WA 98109 (US). **KAPLAN, David, L.** [US/US];  
610 W Prospect St., Seattle, WA 98119 (US).

**Published:**

— without international search report and to be republished upon receipt of that report



WO 2008/073472 A2

(54) Title: ELECTRIC RESOURCE POWER METER IN A POWER AGGREGATION SYSTEM FOR DISTRIBUTED ELECTRIC RESOURCES

(57) Abstract: Systems and methods are described for a power aggregation system. In one implementation, a service establishes individual Internet connections to numerous electric resources intermittently connected to the power grid, such as electric vehicles. The Internet connection may be made over the same wire that connects the resource to the power grid. The service optimizes power flows to suit the needs of each resource and each resource owner, while aggregating flows across numerous resources to suit the needs of the power grid. The service can bring vast numbers of electric vehicle batteries online as a new, dynamically aggregated power resource for the power grid. Electric vehicle owners can participate in an electricity trading economy regardless of where they plug into the power grid.

## **ELECTRIC RESOURCE POWER METER IN A POWER AGGREGATION SYSTEM FOR DISTRIBUTED ELECTRIC RESOURCES**

### **RELATED APPLICATIONS**

[0001] This application claims priority to U.S. Provisional Patent Application No. 60/869,439 to Bridges et al., entitled, "A Distributed Energy Storage Management System," filed December 11, 2006 and incorporated herein by reference; U.S. Provisional Patent Application No. 60/915,347 to Bridges et al., entitled, "Plug-In-Vehicle Management System," filed May 1, 2007 and incorporated herein by reference; and U.S. Patent Application No. 11/836,745 to Bridges et al., entitled, "Electric Resource Power Meter in a Power Aggregation System for Distributed Electric Resources," filed August 9, 2007, and incorporated herein by reference.

### **BACKGROUND**

[0002] Transportation systems, with their high dependence on fossil fuels, are especially carbon-intensive. That is, physical units of work performed in the transportation system typically discharge a significantly larger amount of CO<sub>2</sub> into the atmosphere than the same units of work performed electrically.

[0003] The electric power grid contains limited inherent facility for storing electrical energy. Electricity must be generated constantly to meet uncertain demand, which often results in over-generation (and hence wasted energy) and sometimes results in under-generation (and hence power failures).

[0004] Distributed electric resources, en masse can, in principle, provide a significant resource for addressing the above problems. However, current power services infrastructure lacks provisioning and flexibility that are required for aggregating a large number of small-scale resources (e.g., electric vehicle batteries) to meet medium- and large-scale needs of power services. A single vehicle battery is insignificant when compared with the needs of the power grid. What is needed is a way to coordinate vast numbers of electric vehicle batteries, as electric vehicles become more popular and prevalent.

[0005] Low-level electrical and communication interfaces to enable charging and discharging of electric vehicles with respect to the grid are described in U.S. Patent No. 5,642,270 to Green et al., entitled, "Battery powered electric vehicle and

electrical supply system," incorporated herein by reference. The Green reference describes a bi-directional charging and communication system for grid-connected electric vehicles, but does not address the information processing requirements of dealing with large, mobile populations of electric vehicles, the complexities of billing (or compensating) vehicle owners, nor the complexities of assembling mobile pools of electric vehicles into aggregate power resources robust enough to support firm power service contracts with grid operators.

### **BRIEF DESCRIPTION OF THE DRAWINGS**

- [0006] Fig. 1 is a diagram of an exemplary power aggregation system.
- [0007] Fig. 2 is a diagram of exemplary connections between an electric vehicle, the power grid, and the Internet.
- [0008] Fig. 3 is a block diagram of exemplary connections between an electric resource and a flow control server of the power aggregation system.
- [0009] Fig. 4 is a diagram of an exemplary layout of the power aggregation system.
- [00010] Fig. 5 is a diagram of exemplary control areas in the power aggregation system.
- [00011] Fig. 6 is a diagram of multiple flow control centers in the power aggregation system.
- [00012] Fig. 7 is a block diagram of an exemplary flow control server.
- [00013] Fig. 8 is block diagram of an exemplary remote intelligent power flow module.
- [00014] Fig. 9 is a flow diagram of an exemplary method of power aggregation.
- [00015] Fig. 10 is a flow diagram of an exemplary method of communicatively controlling an electric resource for power aggregation.
- [00016] Fig. 11 is a flow diagram of an exemplary method of metering bidirectional power of an electric resource.
- [00017] Fig. 12 is a flow diagram of an exemplary method of extending a user interface for power aggregation.

## DETAILED DESCRIPTION

### Overview

**[00018]** Described herein is a power aggregation system for distributed electric resources, and associated methods. In one implementation, the exemplary system communicates over the Internet and/or some other public or private networks with numerous individual electric resources connected to a power grid (hereinafter, "grid"). By communicating, the exemplary system can dynamically aggregate these electric resources to provide power services to grid operators (e.g. utilities, Independent System Operators (ISO), etc). "Power services" as used herein, refers to energy delivery as well as other ancillary services including demand response, regulation, spinning reserves, non-spinning reserves, energy imbalance, and similar products. "Aggregation" as used herein refers to the ability to control power flows into and out of a set of spatially distributed electric resources with the purpose of providing a power service of larger magnitude. "Power grid operator" as used herein, refers to the entity that is responsible for maintaining the operation and stability of the power grid within or across an electric control area. The power grid operator may constitute some combination of manual/human action/intervention and automated processes controlling generation signals in response to system sensors. A "control area operator" is one example of a power grid operator. "Control area" as used herein, refers to a contained portion of the electrical grid with defined input and output ports. The net flow of power into this area must equal (within some error tolerance) the sum of the power consumption within the area and power outflow from the area.

**[00019]** "Power grid" as used herein means a power distribution system/network that connects producers of power with consumers of power. The network may include generators, transformers, interconnects, switching stations, substations, feeders, and safety equipment as part of either/both the transmission system (i.e., bulk power) or the distribution system (i.e. retail power). The exemplary power aggregation system is vertically scalable for use with a neighborhood, a city, a sector, a control area, or (for example) one of the eight large-scale Interconnects in the North American Electric Reliability Council (NERC). Moreover, the exemplary system is horizontally scalable for use in providing power services to multiple grid areas simultaneously.

[00020] "Grid conditions" as used herein, means the need for more or less power flowing in or out of a section of the electric power grid, in a response to one of a number of conditions, for example supply changes, demand changes, contingencies and failures, ramping events, etc. These grid conditions typically manifest themselves as power quality events such as under- or over-voltage events and under- or over-frequency events.

[00021] "Power quality events" as used herein typically refers to manifestations of power grid instability including voltage deviations and frequency deviations; additionally, power quality events as used herein also includes other disturbances in the quality of the power delivered by the power grid such as sub-cycle voltage spikes and harmonics.

[00022] "Electric resource" as used herein typically refers to electrical entities that can be commanded to do some or all of these three things: take power (act as load), provide power (act as power generation or source), and store energy. Examples may include battery/charger/inverter systems for electric or hybrid vehicles, repositories of used-but-serviceable electric vehicle batteries, fixed energy storage, fuel cell generators, emergency generators, controllable loads, etc.

[00023] "Electric vehicle" is used broadly herein to refer to pure electric and hybrid electric vehicles, such as plug-in hybrid electric vehicles (PHEVs), especially vehicles that have significant storage battery capacity and that connect to the power grid for recharging the battery. More specifically, electric vehicle means a vehicle that gets some or all of its energy for motion and other purposes from the power grid. Moreover, an electric vehicle has an energy storage system, which may consist of batteries, capacitors, etc., or some combination thereof. An electric vehicle may or may not have the capability to provide power back to the electric grid.

[00024] Electric vehicle "energy storage systems" (batteries, supercapacitors, and/or other energy storage devices) are used herein as a representative example of electric resources intermittently or permanently connected to the grid that can have dynamic input and output of power. Such batteries can function as a power source or a power load. A collection of aggregated electric vehicle batteries can become a statistically stable resource across numerous batteries, despite recognizable tidal connection trends (e.g., an increase in the total number of vehicles connected to the grid at night; a downswing in the collective number of connected

batteries as the morning commute begins, etc.) Across vast numbers of electric vehicle batteries, connection trends are predictable and such batteries become a stable and reliable resource to call upon, should the grid or a part of the grid (such as a person's home in a blackout) experience a need for increased or decreased power. Data collection and storage also enable the power aggregation system to predict connection behavior on a per-user basis.

### Exemplary System

[00025] **Fig. 1** shows an exemplary power aggregation system 100. A flow control center 102 is communicatively coupled with a network, such as a public/private mix that includes the Internet 104, and includes one or more servers 106 providing a centralized power aggregation service. "Internet" 104 will be used herein as representative of many different types of communicative networks and network mixtures. Via a network, such as the Internet 104, the flow control center 102 maintains communication 108 with operators of power grid(s), and communication 110 with remote resources, i.e., communication with peripheral electric resources 112 ("end" or "terminal" nodes /devices of a power network) that are connected to the power grid 114. In one implementation, powerline communicators (PLCs), such as those that include or consist of Ethernet-over-powerline bridges 120 are implemented at connection locations so that the "last mile" (in this case, last feet—e.g., in a residence 124) of Internet communication with remote resources is implemented over the same wire that connects each electric resource 112 to the power grid 114. Thus, each physical location of each electric resource 112 may be associated with a corresponding Ethernet-over-powerline bridge 120 (hereinafter, "bridge") at or near the same location as the electric resource 112. Each bridge 120 is typically connected to an Internet access point of a location owner, as will be described in greater detail below. The communication medium from flow control center 102 to the connection location, such as residence 124, can take many forms, such as cable modem, DSL, satellite, fiber, WiMax, etc. In a variation, electric resources 112 may connect with the Internet by a different medium than the same power wire that connects them to the power grid 114. For example, a given electric resource 112 may have its own wireless capability to connect directly with the Internet 104 and thereby with the flow control center 102.

[00026] Electric resources 112 of the exemplary power aggregation system 100 may include the batteries of electric vehicles connected to the power grid 114 at residences 124, parking lots 126 etc.; batteries in a repository 128, fuel cell generators, private dams, conventional power plants, and other resources that produce electricity and/or store electricity physically or electrically.

[00027] In one implementation, each participating electric resource 112 or group of local resources has a corresponding remote intelligent power flow (IPF) module 134 (hereinafter, "remote IPF module" 134). The centralized flow control center 102 administers the power aggregation system 100 by communicating with the remote IPF modules 134 distributed peripherally among the electric resources 112. The remote IPF modules 134 perform several different functions, including providing the flow control center 102 with the statuses of remote resources; controlling the amount, direction, and timing of power being transferred into or out of a remote electric resource 112; provide metering of power being transferred into or out of a remote electric resource 112; providing safety measures during power transfer and changes of conditions in the power grid 114; logging activities; and providing self-contained control of power transfer and safety measures when communication with the flow control center 102 is interrupted. The remote IPF modules 134 will be described in greater detail below.

[00028] **Fig. 2** shows another view of exemplary electrical and communicative connections to an electric resource 112. In this example, an electric vehicle 200 includes a battery bank 202 and an exemplary remote IPF module 134. The electric vehicle 200 may connect to a conventional wall receptacle (wall outlet) 204 of a residence 124, the wall receptacle 204 representing the peripheral edge of the power grid 114 connected via a residential powerline 206.

[00029] In one implementation, the power cord 208 between the electric vehicle 200 and the wall outlet 204 can be composed of only conventional wire and insulation for conducting alternating current (AC) power to and from the electric vehicle 200. In Fig. 2, a location-specific connection locality module 210 performs the function of network access point—in this case, the Internet access point. A bridge 120 intervenes between the receptacle 204 and the network access point so that the power cord 208 can also carry network communications between the electric vehicle 200 and the receptacle 204. With such a bridge 120 and connection

locality module 210 in place in a connection location, no other special wiring or physical medium is needed to communicate with the remote IPF module 134 of the electric vehicle 200 other than a conventional power cord 208 for providing residential line current at conventional voltage. Upstream of the connection locality module 210, power and communication with the electric vehicle 200 are resolved into the powerline 206 and an Internet cable 104.

[00030] Alternatively, the power cord 208 may include safety features not found in conventional power and extension cords. For example, an electrical plug 212 of the power cord 208 may include electrical and/or mechanical safeguard components to prevent the remote IPF module 134 from electrifying or exposing the male conductors of the power cord 208 when the conductors are exposed to a human user.

[00031] **Fig. 3** shows another implementation of the connection locality module 210 of Fig. 2, in greater detail. In Fig. 3, an electric resource 112 has an associated remote IPF module 134, including a bridge 120. The power cord 208 connects the electric resource 112 to the power grid 114 and also to the connection locality module 210 in order to communicate with the flow control server 106.

[00032] The connection locality module 210 includes another instance of a bridge 120', connected to a network access point 302, which may include such components as a router, switch, and/or modem, to establish a hardwired or wireless connection with, in this case, the Internet 104. In one implementation, the power cord 208 between the two bridges 120 and 120' is replaced by a wireless Internet link, such as a wireless transceiver in the remote IPF module 134 and a wireless router in the connection locality module 210.

#### Exemplary System Layouts

[00033] **Fig. 4** shows an exemplary layout 400 of the power aggregation system 100. The flow control center 102 can be connected to many different entities, e.g., via the Internet 104, for communicating and receiving information. The exemplary layout 400 includes electric resources 112, such as plug-in electric vehicles 200, physically connected to the grid within a single control area 402. The electric resources 112 become an energy resource for grid operators 404 to utilize.



[00034] The exemplary layout 400 also includes end users 406 classified into electric resource owners 408 and electrical connection location owners 410, who may or may not be one and the same. In fact, the stakeholders in an exemplary power aggregation system 100 include the system operator at the flow control center 102, the grid operator 404, the resource owner 408, and the owner of the location 410 at which the electric resource 112 is connected to the power grid 114.

[00035] Electrical connection location owners 410 can include:

[00036] • Rental car lots - rental car companies often have a large portion of their fleet parked in the lot. They can purchase fleets of electric vehicles 200 and, participating in a power aggregation system 100, generate revenue from idle fleet vehicles.

[00037] • Public parking lots - parking lot owners can participate in the power aggregation system 100 to generate revenue from parked electric vehicles 200. Vehicle owners can be offered free parking, or additional incentives, in exchange for providing power services.

[00038] • Workplace parking - employers can participate in a power aggregation system 100 to generate revenue from parked employee electric vehicles 200. Employees can be offered incentives in exchange for providing power services.

[00039] • Residences - a home garage can merely be equipped with a connection locality module 210 to enable the homeowner to participate in the power aggregation system 100 and generate revenue from a parked car. Also, the vehicle battery 202 and associated power electronics within the vehicle can provide local power backup power during times of peak load or power outages.

[00040] • Residential neighborhoods - neighborhoods can participate in a power aggregation system 100 and be equipped with power-delivery devices (deployed, for example, by homeowner cooperative groups) that generate revenue from parked electric vehicles 200.

[00041] • The grid operations 116 of Fig. 4 collectively include interactions with energy markets 412, the interactions of grid operators 404, and the interactions of automated grid controllers 118 that perform automatic physical control of the power grid 114.

[00042] The flow control center 102 may also be coupled with information sources 414 for input of weather reports, events, price feeds, etc., collectively called

acquired information. Other data sources 414 include the system stakeholders, public databases, and historical system data, which may be used to optimize system performance and to satisfy constraints on the exemplary power aggregation system 100.

[00043] Thus, an exemplary power aggregation system 100 may consist of components that:

[00044] • communicate with the electric resources 112 to gather data and actuate charging/discharging of the electric resources 112;

[00045] • gather real-time energy prices;

[00046] • gather real-time resource statistics;

[00047] • predict behavior of electric resources 112 (connectedness, location, state (such as battery State-Of-Charge) at time of connect/disconnect);

[00048] • predict behavior of the power grid 114/ load;

[00049] • encrypt communications for privacy and data security;

[00050] • actuate charging of electric vehicles 200 to optimize some figure(s) of merit;

[00051] • offer guidelines or guarantees about load availability for various points in the future, etc.

[00052] These components can be running on a single computing resource (computer, etc.), or on a distributed set of resources (either physically co-located or not).

[00053] Exemplary IPF systems 100 in such a layout 400 can provide many benefits: for example, lower-cost ancillary services (i.e., power services), fine-grained (both temporally and spatially) control over resource scheduling, guaranteed reliability and service levels, increased service levels via intelligent resource scheduling, firming of intermittent generation sources such as wind and solar power generation.

[00054] The exemplary power aggregation system 100 enables a grid operator 404 to control the aggregated electric resources 112 connected to the power grid 114. An electric resource 112 can act as a power source, load, or storage, and the resource 112 may exhibit combinations of these properties. Control of an electric resource 112 is the ability to actuate power consumption, generation, or energy storage from an aggregate of these electric resources 112.

[00055] **Fig. 5** shows the role of multiple control areas 402 in the exemplary power aggregation system 100. Each electric resource 112 can be connected to the power aggregation system 100 within a specific electrical control area. A single instance of the flow control center 102 can administer electric resources 112 from multiple distinct control areas 501 (e.g., control areas 502, 504, and 506). In one implementation, this functionality is achieved by logically partitioning resources within the power aggregation system 100. For example, when the control areas 402 include an arbitrary number of control areas, control area "A" 502, control area "B" 504, ..., control area "n" 506, then grid operations 116 can include corresponding control area operators 508, 510, ..., and 512. Further division into a control hierarchy that includes control division groupings above and below the illustrated control areas 402 allows the power aggregation system 100 to scale to power grids 114 of different magnitudes and/or to varying numbers of electric resources 112 connected with a power grid 114.

[00056] **Fig. 6** shows an exemplary layout 600 of an exemplary power aggregation system 100 that uses multiple centralized flow control centers 102 and 102'. Each flow control center 102 and 102' has its own respective end users 406 and 406'. Control areas 402 to be administered by each specific instance of a flow control center 102 can be assigned dynamically. For example, a first flow control center 102 may administer control area A 502 and control area B 504, while a second flow control center 102' administers control area n 506. Likewise, corresponding control area operators (508, 510, and 512) are served by the same flow control center 102 that serves their respective different control areas.

#### Exemplary Flow Control Server

[00057] **Fig. 7** shows an exemplary server 106 of the flow control center 102. The illustrated implementation in Fig. 7 is only one example configuration, for descriptive purposes. Many other arrangements of the illustrated components or even different components constituting an exemplary server 106 of the flow control center 102 are possible within the scope of the subject matter. Such an exemplary server 106 and flow control center 102 can be executed in hardware, software, or combinations of hardware, software, firmware, etc.

[00058] The exemplary flow control server 106 includes a connection manager 702 to communicate with electric resources 112, a prediction engine 704 that may include a learning engine 706 and a statistics engine 708, a constraint optimizer 710, and a grid interaction manager 712 to receive grid control signals 714. Grid control signals 714 may include generation control signals, such as automated generation control (AGC) signals. The flow control server 106 may further include a database / information warehouse 716, a web server 718 to present a user interface to electric resource owners 408, grid operators 404, and electrical connection location owners 410; a contract manager 720 to negotiate contract terms with energy markets 412, and an information acquisition engine 414 to track weather, relevant news events, etc., and download information from public and private databases 722 for predicting behavior of large groups of the electric resources 112, monitoring energy prices, negotiating contracts, etc.

#### Operation of an Exemplary Flow Control Server

[00059] The connection manager 702 maintains a communications channel with each electric resource 112 that is connected to the power aggregation system 100. That is, the connection manager 702 allows each electric resource 112 to log on and communicate, e.g., using Internet Protocol (IP) if the network is the Internet 104. In other words, the electric resources 112 call home. That is, in one implementation they always initiate the connection with the server 106. This facet enables the exemplary IPF modules 134 to work around problems with firewalls, IP addressing, reliability, etc.

[00060] For example, when an electric resource 112, such as an electric vehicle 200 plugs in at home 124, the IPF module 134 can connect to the home's router via the powerline connection. The router will assign the vehicle 200 an address (DHCP), and the vehicle 200 can connect to the server 106 (no holes in the firewall needed from this direction).

[00061] If the connection is terminated for any reason (including the server instance dies), then the IPF module 134 knows to call home again and connect to the next available server resource.

[00062] The grid interaction manager 712 receives and interprets signals from the interface of the automated grid controller 118 of a grid operator 404. In one

implementation, the grid interaction manager 712 also generates signals to send to automated grid controllers 118. The scope of the signals to be sent depends on agreements or contracts between grid operators 404 and the exemplary power aggregation system 100. In one scenario the grid interaction manager 712 sends information about the availability of aggregate electric resources 112 to receive power from the grid 114 or supply power to the grid 114. In another variation, a contract may allow the grid interaction manager 712 to send control signals to the automated grid controller 118—to control the grid 114, subject to the built-in constraints of the automated grid controller 118 and subject to the scope of control allowed by the contract.

[00063] The database 716 can store all of the data relevant to the power aggregation system 100 including electric resource logs, e.g., for electric vehicles 200, electrical connection information, per-vehicle energy metering data, resource owner preferences, account information, etc.

[00064] The web server 718 provides a user interface to the system stakeholders, as described above. Such a user interface serves primarily as a mechanism for conveying information to the users, but in some cases, the user interface serves to acquire data, such as preferences, from the users. In one implementation, the web server 718 can also initiate contact with participating electric resource owners 408 to advertise offers for exchanging electrical power.

[00065] The bidding/contract manager 720 interacts with the grid operators 404 and their associated energy markets 412 to determine system availability, pricing, service levels, etc.

[00066] The information acquisition engine 414 communicates with public and private databases 722, as mentioned above, to gather data that is relevant to the operation of the power aggregation system 100.

[00067] The prediction engine 704 may use data from the data warehouse 716 to make predictions about electric resource behavior, such as when electric resources 112 will connect and disconnect, global electric resource availability, electrical system load, real-time energy prices, etc. The predictions enable the power aggregation system 100 to utilize more fully the electric resources 112 connected to the power grid 114. The learning engine 706 may track, record, and process actual electric resource behavior, e.g., by learning behavior of a sample or cross-section of

a large population of electric resources 112. The statistics engine 708 may apply various probabilistic techniques to the resource behavior to note trends and make predictions.

[00068] In one implementation, the prediction engine 704 performs predictions via collaborative filtering. The prediction engine 704 can also perform per-user predictions of one or more parameters, including, for example, connect-time, connect duration, state-of-charge at connect time, and connection location. In order to perform per-user prediction, the prediction engine 704 may draw upon information, such as historical data, connect time (day of week, week of month, month of year, holidays, etc.), state-of-charge at connect, connection location, etc. In one implementation, a time series prediction can be computed via a recurrent neural network, a dynamic Bayesian network, or other directed graphical model.

[00069] In one scenario, for one user disconnected from the grid 114, the prediction engine 704 can predict the time of the next connection, the state-of-charge at connection time, the location of the connection (and may assign it a probability/likelihood). Once the resource 112 has connected, the time-of-connection, state-of-charge at-connection, and connection location become further inputs to refinements of the predictions of the connection duration. These predictions help to guide predictions of total system availability as well as to determine a more accurate cost function for resource allocation.

[00070] Building a parameterized prediction model for each unique user is not always scalable in time or space. Therefore, in one implementation, rather than use one model for each user in the system 100, the prediction engine 704 builds a reduced set of models where each model in the reduced set is used to predict the behavior of many users. To decide how to group similar users for model creation and assignment, the system 100 can identify features of each user, such as number of unique connections/disconnections per day, typical connection time(s), average connection duration, average state-of-charge at connection time, etc., and can create clusters of users in either a full feature space or in some reduced feature space that is computed via a dimensionality reduction algorithm such as Principal Components Analysis, Random Projection, etc. Once the prediction engine 704 has assigned users to a cluster, the collective data from all of the users in that cluster is used to create a predictive model that will be used for the predictions of each user in

the cluster. In one implementation, the cluster assignment procedure is varied to optimize the system 100 for speed (less clusters), for accuracy (more clusters), or some combination of the two.

[00071] This exemplary clustering technique has multiple benefits. First, it enables a reduced set of models, and therefore reduced model parameters, which reduces the computation time for making predictions. It also reduces the storage space of the model parameters. Second, by identifying traits (or features) of new users to the system 100, these new users can be assigned to an existing cluster of users with similar traits, and the cluster model, built from the extensive data of the existing users, can make more accurate predictions about the new user more quickly because it is leveraging the historical performance of similar users. Of course, over time, individual users may change their behaviors and may be reassigned to new clusters that fit their behavior better.

[00072] The constraint optimizer 710 combines information from the prediction engine 704, the data warehouse 716, and the contract manager 720 to generate resource control signals that will satisfy the system constraints. For example, the constraint optimizer 710 can signal an electric vehicle 200 to charge its battery bank 202 at a certain charging rate and later to discharge the battery bank 202 for uploading power to the power grid 114 at a certain upload rate: the power transfer rates and the timing schedules of the power transfers optimized to fit the tracked individual connect and disconnect behavior of the particular electric vehicle 200 and also optimized to fit a daily power supply and demand "breathing cycle" of the power grid 114.

[00073] In one implementation, the constraint optimizer 710 plays a key role in converting grid control signals 714 or information sources 414 into vehicle control signals, mediated by the connection manager 702. Mapping grid control signals 714 from a grid operator 404 or information sources 414 into control signals that are sent to each unique electrical resource 112 in the system 100 is an example of a specific constraint optimization problem.

[00074] Each resource 112 has associated constraints, either hard or soft. Examples of resource constraints may include: price sensitivity of the owner, vehicle state-of-charge (e.g., if the vehicle 200 is fully charged, it cannot participate in loading the grid 114), predicted amount of time until the resource 112 disconnects

from the system 100, owner sensitivity to revenue versus state-of-charge, electrical limits of the resource 114, manual charging overrides by resource owners 408, etc. The constraints on a particular resource 112 can be used to assign a cost for activating each of the resource's particular actions. For example, a resource whose storage system 202 has little energy stored in it will have a low cost associated with the charging operation, but a very high cost for the generation operation. A fully charged resource 112 that is predicted to be available for ten hours will have a lower cost generation operation than a fully charged resource 112 that is predicted to be disconnected within the next 15 minutes, representing the negative consequence of delivering a less-than-full resource to its owner.

[00075] The following is one example scenario of converting one generating signal 714 that comprises a system operating level (e.g. -10 megawatts to +10 megawatts, where + represents load, - represents generation) to a vehicle control signal. It is worth noting that because the system 100 can meter the actual power flows in each resource 112, the actual system operating level is known at all times.

[00076] In this example, assume the initial system operating level is 0 megawatts, no resources are active (taking or delivering power from the grid), and the negotiated aggregation service contract level for the next hour is +/- 5 megawatts.

[00077] In this implementation, the exemplary power aggregation system 100 maintains three lists of available resources 112. The first list contains resources 112 that can be activated for charging (load) in priority order. There is a second list of the resources 112 ordered by priority for discharging (generation). Each of the resources 112 in these lists (e.g., all resources 112 can have a position in both lists) have an associated cost. The priority order of the lists is directly related to the cost (i.e., the lists are sorted from lowest cost to highest cost). Assigning cost values to each resource 112 is important because it enables the comparison of two operations that achieve similar results with respect to system operation. For example, adding one unit of charging (load, taking power from the grid) to the system is equivalent to removing one unit of generation. To perform any operation that increases or decreases the system output, there may be multiple action choices and in one implementation the system 100 selects the lowest cost operation. The third list of resources 112 contains resources with hard constraints. For example,



resources whose owner's 408 have overridden the system 100 to force charging will be placed on the third list of static resources.

[00078] At time "1," the grid-operator-requested operating level changes to +2 megawatts. The system activates charging the first 'n' resources from the list, where 'n' is the number of resources whose additive load is predicted to equal 2 megawatts. After the resources are activated, the result of the activations are monitored to determine the actual result of the action. If more than 2 megawatts of load is active, the system will disable charging in reverse priority order to maintain system operation within the error tolerance specified by the contract.

[00079] From time "1" until time "2," the requested operating level remains constant at 2 megawatts. However, the behavior of some of the electrical resources may not be static. For example, some vehicles 200 that are part of the 2 megawatts system operation may become full (state-of-charge = 100%) or may disconnect from the system 100. Other vehicles 200 may connect to the system 100 and demand immediate charging. All of these actions will cause a change in the operating level of the power aggregation system 100. Therefore, the system 100 continuously monitors the system operating level and activates or deactivates resources 112 to maintain the operating level within the error tolerance specified by the contract.

[00080] At time "2," the grid-operator-requested operating level decreases to -1 megawatts. The system consults the lists of available resources and chooses the lowest cost set of resources to achieve a system operating level of -1 megawatts. Specifically, the system moves sequentially through the priority lists, comparing the cost of enabling generation versus disabling charging, and activating the lowest cost resource at each time step. Once the operating level reaches -1 megawatts, the system 100 continues to monitor the actual operating level, looking for deviations that would require the activation of an additional resource 112 to maintain the operating level within the error tolerance specified by the contract.

[00081] In one implementation, an exemplary costing mechanism is fed information on the real-time grid generation mix to determine the marginal consequences of charging or generation (vehicle 200 to grid 114) on a "carbon footprint," the impact on fossil fuel resources and the environment in general. The exemplary system 100 also enables optimizing for any cost metric, or a weighted combination of several. The system 100 can optimize figures of merit that may

include, for example, a combination of maximizing economic value and minimizing environmental impact, etc.

[00082] In one implementation, the system 100 also uses cost as a temporal variable. For example, if the system 100 schedules a discharged pack to charge during an upcoming time window, the system 100 can predict its look-ahead cost profile as it charges, allowing the system 100 to further optimize, adaptively. That is, in some circumstances the system 100 knows that it will have a high-capacity generation resource by a certain future time.

[00083] Multiple components of the flow control server 106 constitute a scheduling system that has multiple functions and components:

[00084] • data collection (gathers real-time data and stores historical data);

[00085] • projections via the prediction engine 704, which inputs real-time data, historical data, etc.; and outputs resource availability forecasts;

[00086] • optimizations built on resource availability forecasts, constraints, such as command signals from grid operators 404, user preferences, weather conditions, etc. The optimizations can take the form of resource control plans that optimize a desired metric.

[00087] The scheduling function can enable a number of useful energy services, including:

[00088] • ancillary services, such as rapid response services and fast regulation;

[00089] • energy to compensate for sudden, foreseeable, or unexpected grid imbalances;

[00090] • response to routine and unstable demands;

[00091] • firming of renewable energy sources (e.g. complementing wind-generated power).

[00092] An exemplary power aggregation system 100 aggregates and controls the load presented by many charging/uploading electric vehicles 200 to provide power services (ancillary energy services) such as regulation and spinning reserves. Thus, it is possible to meet call time requirements of grid operators 404 by summing multiple electric resources 112. For example, twelve operating loads of 5kW each can be disabled to provide 60kW of spinning reserves for one hour. However, if each load can be disabled for at most 30 minutes and the minimum call time is two hours, the loads can be disabled in series (three at a time) to provide 15kW of

reserves for two hours. Of course, more complex interleavings of individual electric resources by the power aggregation system 100 are possible.

[00093] For a utility (or electrical power distribution entity) to maximize distribution efficiency, the utility needs to minimize reactive power flows. Typically, there are a number of methods used to minimize reactive power flows including switching inductor or capacitor banks into the distribution system to modify the power factor in different parts of the system. To manage and control this dynamic Volt-Amperes Reactive (VAR) support effectively, it must be done in a location-aware manner. In one implementation, the power aggregation system 100 includes power-factor correction circuitry placed in electric vehicles 200 with the exemplary remote IPF module 134, thus enabling such a service. Specifically, the electric vehicles 200 can have capacitors (or inductors) that can be dynamically connected to the grid, independent of whether the electric vehicle 200 is charging, delivering power, or doing nothing. This service can then be sold to utilities for distribution level dynamic VAR support. The power aggregation system 100 can both sense the need for VAR support in a distributed manner and use the distributed remote IPF modules 134 to take actions that provide VAR support without grid operator 404 intervention.

#### Exemplary Remote IPF Module

[00094] **Fig. 8** shows the remote IPF module 134 of Figs. 1 and 2 in greater detail. The illustrated remote IPF module 134 is only one example configuration, for descriptive purposes. Many other arrangements of the illustrated components or even different components constituting an exemplary remote IPF module 134 are possible within the scope of the subject matter. Such an exemplary remote IPF module 134 has some hardware components and some components that can be executed in hardware, software, or combinations of hardware, software, firmware, etc.

[00095] The illustrated example of a remote IPF module 134 is represented by an implementation suited for an electric vehicle 200. Thus, some vehicle systems 800 are included as part of the exemplary remote IPF module 134 for the sake of description. However, in other implementations, the remote IPF module 134 may exclude some or all of the vehicles systems 800 from being counted as components of the remote IPF module 134.

[00096] The depicted vehicle systems 800 include a vehicle computer and data interface 802, an energy storage system, such as a battery bank 202, and an inverter / charger 804. Besides vehicle systems 800, the remote IPF module 134 also includes a communicative power flow controller 806. The communicative power flow controller 806 in turn includes some components that interface with AC power from the grid 114, such as a powerline communicator, for example an Ethernet-over-powerline bridge 120, and a current or current/voltage (power) sensor 808, such as a current sensing transformer.

[00097] The communicative power flow controller 806 also includes Ethernet and information processing components, such as a processor 810 or microcontroller and an associated Ethernet media access control (MAC) address 812; volatile random access memory 814, nonvolatile memory 816 or data storage, an interface such as an RS-232 interface 818 or a CANbus interface 820; an Ethernet physical layer interface 822, which enables wiring and signaling according to Ethernet standards for the physical layer through means of network access at the MAC / Data Link Layer and a common addressing format. The Ethernet physical layer interface 822 provides electrical, mechanical, and procedural interface to the transmission medium—i.e., in one implementation, using the Ethernet-over-powerline bridge 120. In a variation, wireless or other communication channels with the Internet 104 are used in place of the Ethernet-over-powerline bridge 120.

[00098] The communicative power flow controller 806 also includes a bidirectional power flow meter 824 that tracks power transfer to and from each electric resource 112, in this case the battery bank 202 of an electric vehicle 200.

[00099] The communicative power flow controller 806 operates either within, or connected to an electric vehicle 200 or other electric resource 112 to enable the aggregation of electric resources 112 introduced above (e.g., via a wired or wireless communication interface). These above-listed components may vary among different implementations of the communicative power flow controller 806, but implementations typically include:

[000100] • an intra-vehicle communications mechanism that enables communication with other vehicle components;

[000101] • a mechanism to communicate with the flow control center 102;

[000102] • a processing element;

[000103] • a data storage element;

[000104] • a power meter; and

[000105] • optionally, a user interface.

[000106] Implementations of the communicative power flow controller 806 can enable functionality including:

[000107] • executing pre-programmed or learned behaviors when the electric resource 112 is offline (not connected to Internet 104, or service is unavailable);

[000108] • storing locally-cached behavior profiles for "roaming" connectivity (what to do when charging on a foreign system or in disconnected operation, i.e., when there is no network connectivity);

[000109] • allowing the user to override current system behavior; and

[000110] • metering power-flow information and caching meter data during offline operation for later transaction.

[000111] Thus, the communicative power flow controller 806 includes a central processor 810, interfaces 818 and 820 for communication within the electric vehicle 200, a powerline communicator, such as an Ethernet-over-powerline bridge 120 for communication external to the electric vehicle 200, and a power flow meter 824 for measuring energy flow to and from the electric vehicle 200 via a connected AC powerline 208.

#### Operation of the Exemplary Remote IPF Module

[000112] Continuing with electric vehicles 200 as representative of electric resources 112, during periods when such an electric vehicle 200 is parked and connected to the grid 114, the remote IPF module 134 initiates a connection to the flow control server 106, registers itself, and waits for signals from the flow control server 106 that direct the remote IPF module 134 to adjust the flow of power into or out of the electric vehicle 200. These signals are communicated to the vehicle computer 802 via the data interface, which may be any suitable interface including the RS-232 interface 818 or the CANbus interface 820. The vehicle computer 802, following the signals received from the flow control server 106, controls the inverter / charger 804 to charge the vehicle's battery bank 202 or to discharge the battery bank 202 in upload to the grid 114.

[000113] Periodically, the remote IPF module 134 transmits information regarding energy flows to the flow control server 106. If, when the electric vehicle 200 is connected to the grid 114, there is no communications path to the flow control server 106 (i.e., the location is not equipped properly, or there is a network failure), the electric vehicle 200 can follow a preprogrammed or learned behavior of off-line operation, e.g., stored as a set of instructions in the nonvolatile memory 816. In such a case, energy transactions can also be cached in nonvolatile memory 816 for later transmission to the flow control server 106.

[000114] During periods when the electric vehicle 200 is in operation as transportation, the remote IPF module 134 listens passively, logging select vehicle operation data for later analysis and consumption. The remote IPF module 134 can transmit this data to the flow control server 106 when a communications channel becomes available.

#### Exemplary Power Flow Meter

[000115] Power is the rate of energy consumption per interval of time. Power indicates the quantity of energy transferred during a certain period of time, thus the units of power are quantities of energy per unit of time. The exemplary power flow meter 824 measures power for a given electric resource 112 across a bi-directional flow—e.g., power from grid 114 to electric vehicle 200 or from electric vehicle 200 to the grid 114. In one implementation, the remote IPF module 134 can locally cache readings from the power flow meter 824 to ensure accurate transactions with the central flow control server 106, even if the connection to the server is down temporarily, or if the server itself is unavailable.

[000116] The exemplary power flow meter 824, in conjunction with the other components of the remote IPF module 134 enables system-wide features in the exemplary power aggregation system 100 that include:

[000117] • tracking energy usage on an electric resource-specific basis;

[000118] • power-quality monitoring (checking if voltage, frequency, etc. deviate from their nominal operating points, and if so, notifying grid operators, and potentially modifying resource power flows to help correct the problem);

[000119] • vehicle-specific billing and transactions for energy usage;

[000120] • mobile billing (support for accurate billing when the electric resource owner 408 is not the electrical connection location owner 410 (i.e., not the meter account owner). Data from the power flow meter 824 can be captured at the electric vehicle 200 for billing;

[000121] • integration with a smart meter at the charging location (bi-directional information exchange); and

[000122] • tamper resistance (e.g., when the power flow meter 824 is protected within an electric resource 112 such as an electric vehicle 200).

### Exemplary Methods

[000123] **Fig. 9** shows an exemplary method 900 of power aggregation. In the flow diagram, the operations are summarized in individual blocks. The exemplary method 900 may be performed by hardware, software, or combinations of hardware, software, firmware, etc., for example, by components of the exemplary power aggregation system 100.

[000124] At block 902, communication is established with each of multiple electric resources connected to a power grid. For example, a central flow control service can manage numerous intermittent connections with mobile electric vehicles, each of which may connect to the power grid at various locations. An in-vehicle remote agent connects each vehicle to the Internet when the vehicle connects to the power grid.

[000125] At block 904, the electric resources are individually signaled to provide power to or take power from the power grid.

[000126] **Fig. 10** is a flow diagram of an exemplary method of communicatively controlling an electric resource for power aggregation. In the flow diagram, the operations are summarized in individual blocks. The exemplary method 1000 may be performed by hardware, software, or combinations of hardware, software, firmware, etc., for example, by components of the exemplary intelligent power flow (IPF) module 134.

[000127] At block 1002, communication is established between an electric resource and a service for aggregating power.

[000128] At block 1004, information associated with the electric resource is communicated to the service.

[000129] At block 1006, a control signal based in part upon the information is received from the service.

[000130] At block 1008, the resource is controlled, e.g., to provide power to the power grid or to take power from the grid, i.e., for storage.

[000131] At block 1010, bidirectional power flow of the electric device is measured, and used as part of the information associated with the electric resource that is communicated to the service at block 1004.

[000132] Fig. 11 is a flow diagram of an exemplary method of metering bidirectional power of an electric resource. In the flow diagram, the operations are summarized in individual blocks. The exemplary method 1100 may be performed by hardware, software, or combinations of hardware, software, firmware, etc., for example, by components of the exemplary power flow meter 824.

[000133] At block 1102, energy transfer between an electric resource and a power grid is measured bidirectionally.

[000134] At block 1104, the measurements are sent to a service that aggregates power based in part on the measurements.

[000135] Fig. 12 is a flow diagram of an exemplary method of extending a user interface for power aggregation. In the flow diagram, the operations are summarized in individual blocks. The exemplary method 1200 may be performed by hardware, software, or combinations of hardware, software, firmware, etc., for example, by components of the exemplary power aggregation system 100.

[000136] At block 1202, a user interface is associated with an electric resource. The user interface may be displayed in, on, or near an electric resource, such as an electric vehicle that includes an energy storage system, or the user interface may be displayed on a device associated with the owner of the electric resource, such as a cell phone or portable computer.

[000137] At block 1204, power aggregation preferences and constraints are input via the user interface. In other words, a user may control a degree of participation of the electric resource in a power aggregation scenario via the user interface. Or, the user may control the characteristics of such participation.



Conclusion

[000138] Although exemplary systems and methods have been described in language specific to structural features and/or methodological acts, it is to be understood that the subject matter defined in the appended claims is not necessarily limited to the specific features or acts described. Rather, the specific features and acts are disclosed as exemplary forms of implementing the claimed methods, devices, systems, etc.

CLAIMS

1. An apparatus, comprising:  
a meter to measure bidirectional energy transfer between an electric resource and a power grid; and  
an interface to send the measurements to a service that aggregates power based in part upon the measurements.
2. The apparatus as recited in claim 1, wherein the service aggregates a capability of distributed electric resources to take power, provide power, or store energy based on the measurements.
3. The apparatus as recited in claim 1, wherein the electric resource comprises an electric vehicle, a hybrid electric vehicle, or a vehicle that obtains at least some power for motion from an electric storage resource.
4. The apparatus as recited in claim 1, wherein the meter continuously calculates an instantaneous electrical power integrated over time to determine energy used and sends the calculated instantaneous electrical power and/or the energy used to the power aggregation service.
5. The apparatus as recited in claim 4, wherein the meter caches at least some of the measurements and/or at least some of the calculations in a local data store for future transactions with the service.
6. The apparatus as recited in claim 5, wherein the meter caches the measurements or calculations in the local data store when the service is offline or when communication with the service is disconnected, and uploads the measurements or calculations to the service when the service is online and connected.

7. The apparatus as recited in claim 1, further comprising a power quality monitor to detect power quality problems, including deviations from nominal voltage (such as voltage sags or swells), voltage harmonics, sub-cycle impulses, fast impulses, deviations from nominal frequency, deviations from unity power factor, and high frequency noise and to transmit detected quality problems to the power aggregation service.

8. The apparatus as recited in claim 1, wherein the meter measures parameters of a load and supply including maximum demand, power factor, and reactive power used.

9. The apparatus as recited in claim 1, wherein the meter computes a value of electricity consumed and/or provided, the value of the electricity varying by a time of day, a day of week, and a seasonality.

10. The apparatus as recited in claim 1, further comprising:  
a transaction engine;  
a user interface; and  
wherein the transaction engine provides a user a power transfer timing option or a power transfer pricing option.

11. The apparatus as recited in claim 10, wherein the transaction engine provides electric resource-specific billing of energy usage and crediting of energy supply based on input from the meter.

12. The apparatus as recited in claim 11, wherein the transaction engine and meter provide mobile billing, wherein an owner of the electric resource is not the same as an owner of an account associated with the power grid connection location.

13. The apparatus as recited in claim 12, further comprising an interface for bidirectional information exchange with a permanently-installed meter

associated with a location where the electric resource is connected to the power grid.

14. The apparatus as recited in claim 1, wherein information from the meter is encrypted for transmission to the service or storage in the local data store and decrypted at the service.

15. The apparatus as recited in claim 1, further comprising a tamper-proof meter.

16. The apparatus as recited in claim 1, further comprising multiple instances of the apparatus associated with respective distributed electric resources for tracking energy usage on a resource-specific basis.

17. A method, comprising:  
measuring bidirectional energy transfer between an electric resource and a power grid; and  
sending the bidirectional energy transfer measurements to a service that aggregates power based in part on the measurements.

18. The method as recited in claim 17, wherein the service aggregates a capability of distributed electric resources to take power, provide power, or store energy based on the measurements.

19. The method as recited in claim 17, wherein a component associated with the electric resource performs the measuring.

20. The method as recited in claim 17, wherein the electric resource comprises a vehicle energy storage system.

21. A system, comprising:  
means for measuring bidirectional energy transfer between an electric resource and a power grid; and

means for sending the energy transfer measurements to a service that aggregates a capability of distributed electric resources to take power, provide power, or store energy .

22. The system as recited in claim 21, further comprising means for billing or crediting a user based on the energy transfer measurements.

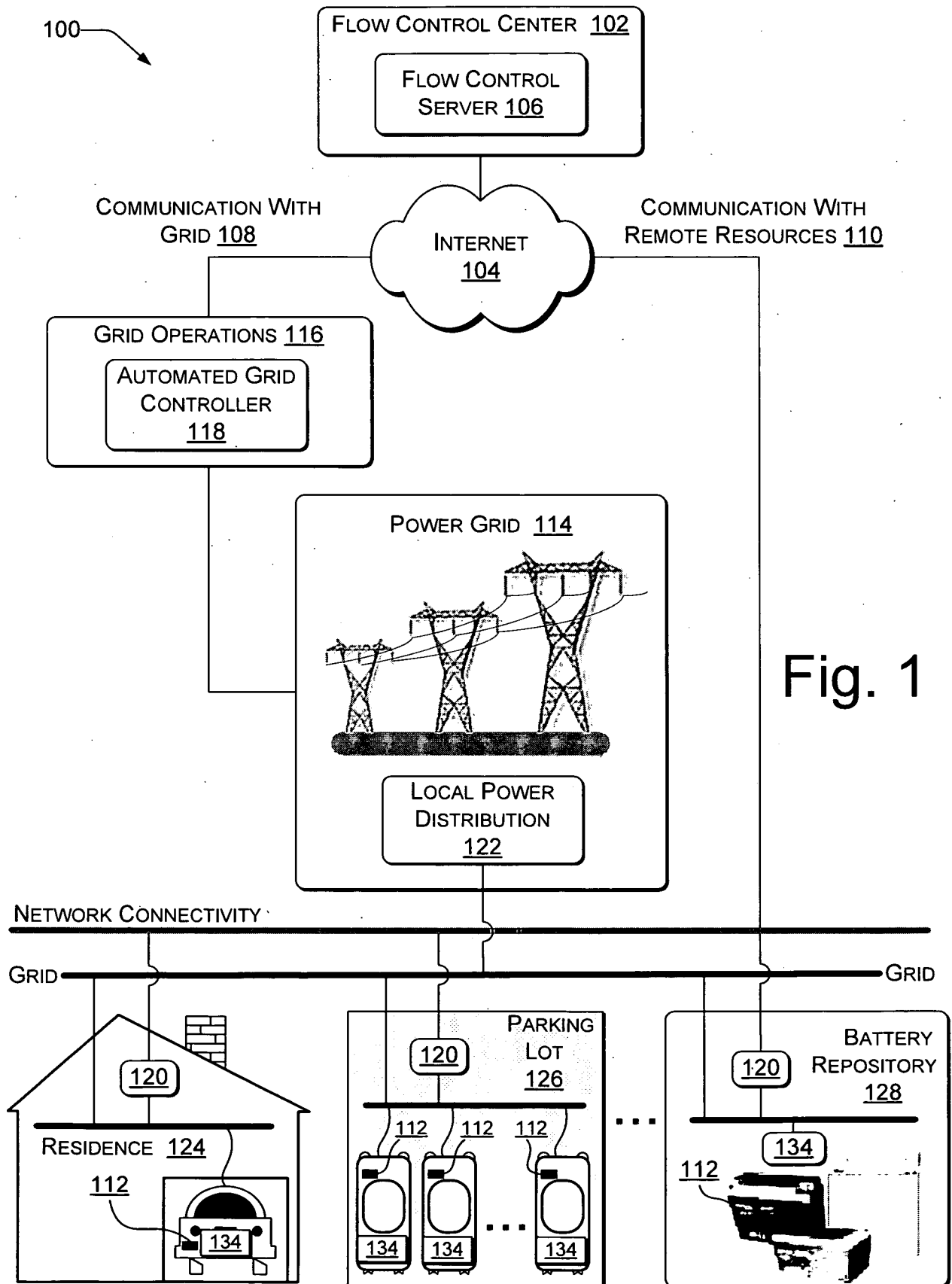

Fig. 1

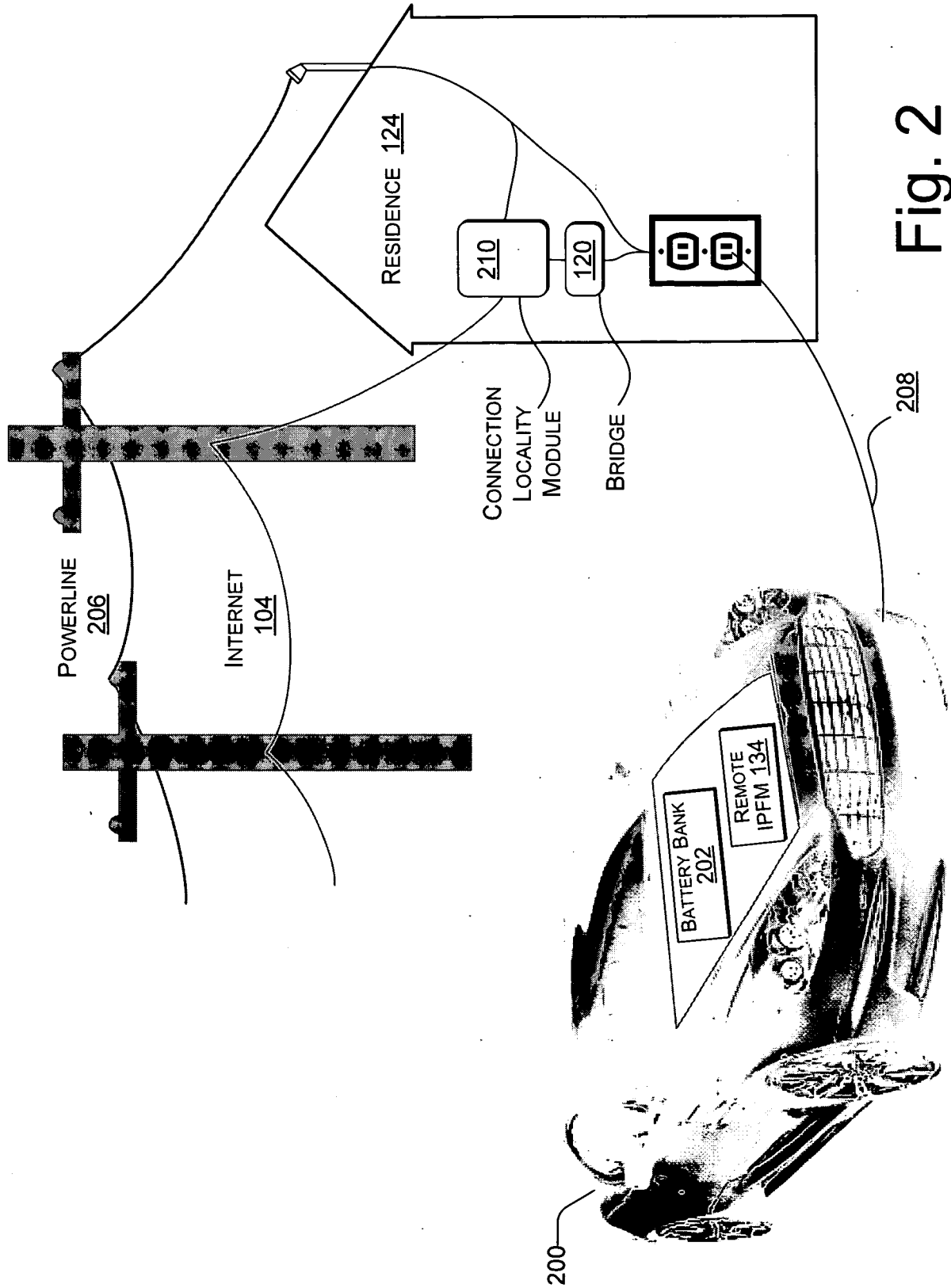

Fig. 2

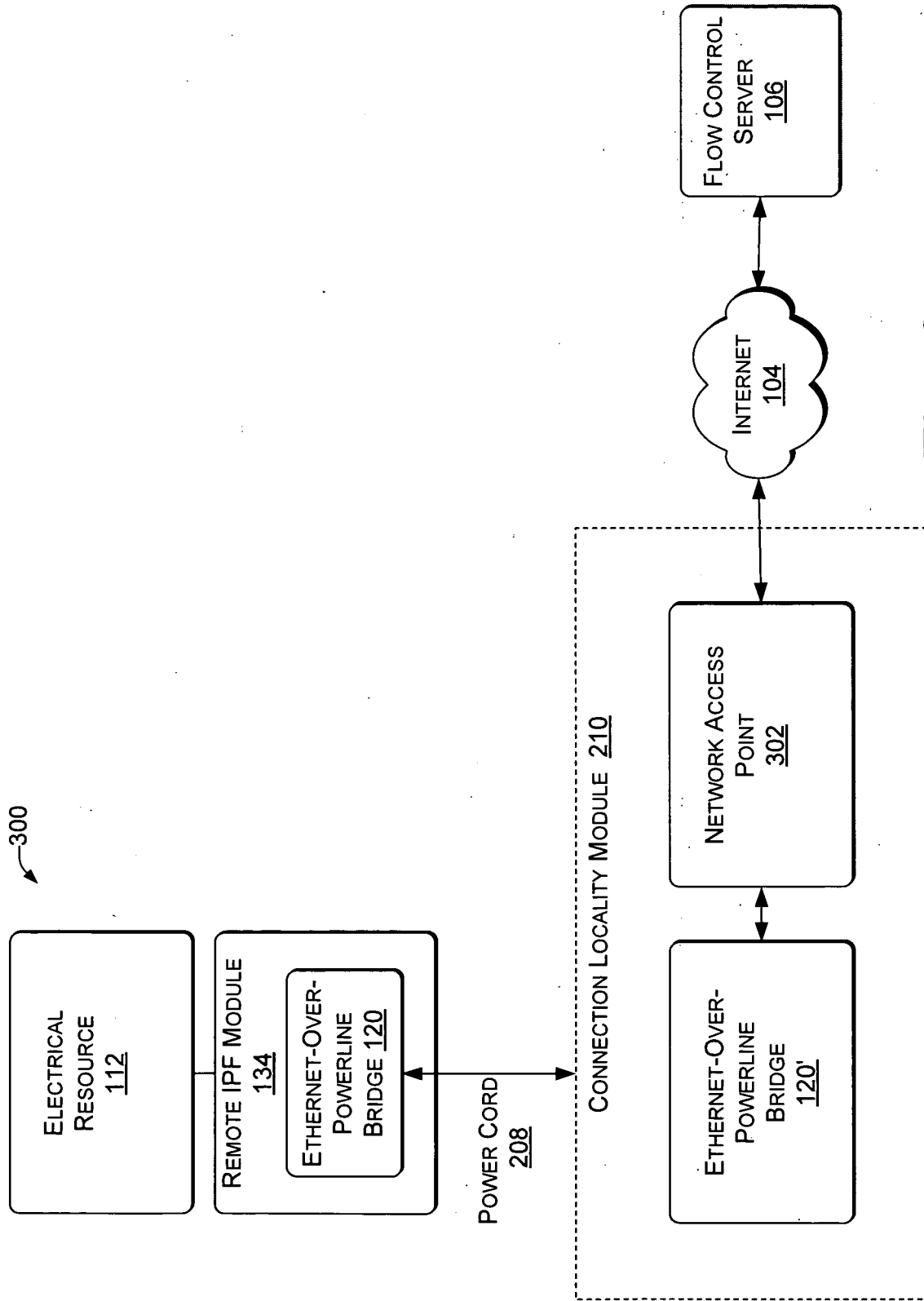

Fig. 3



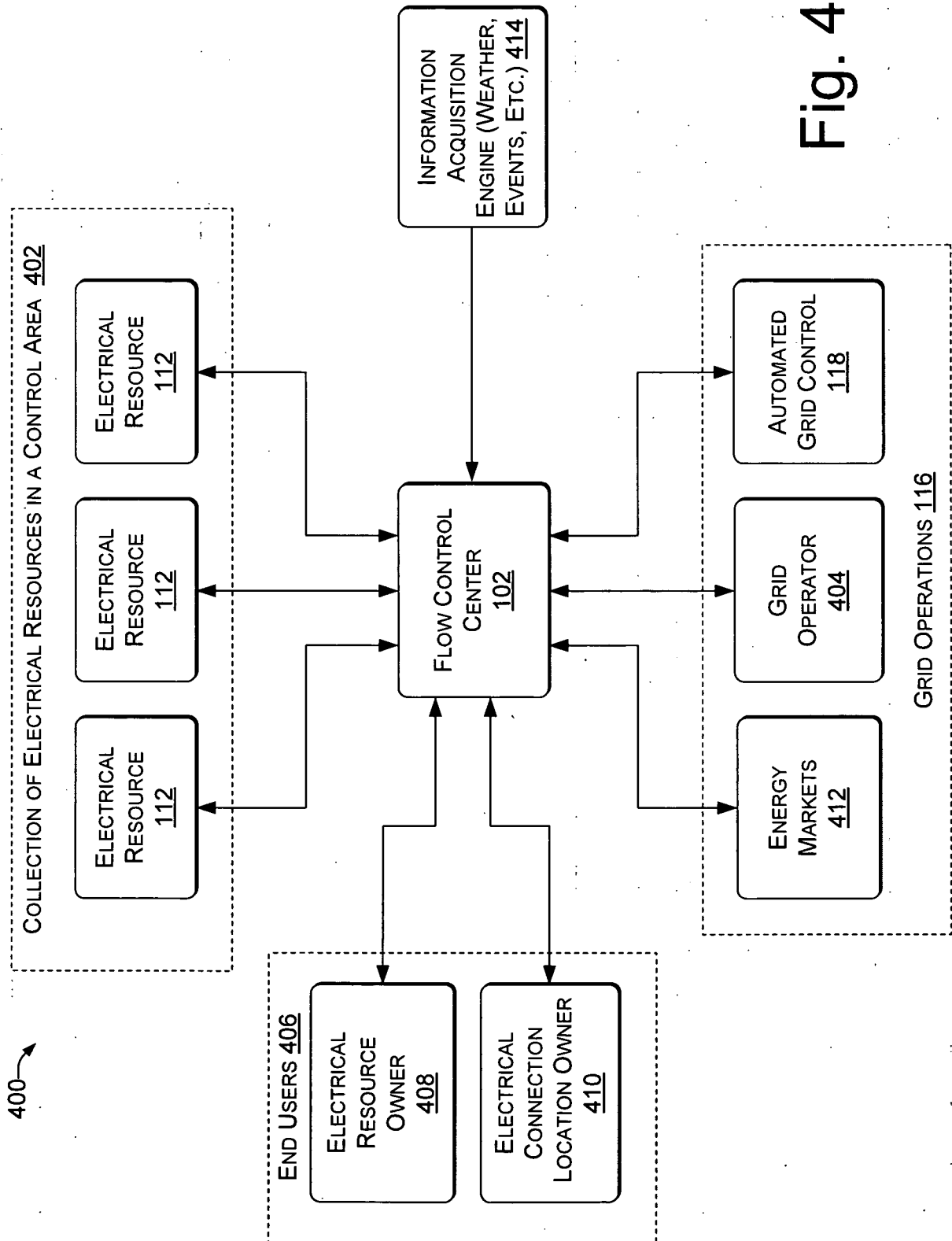

Fig. 4

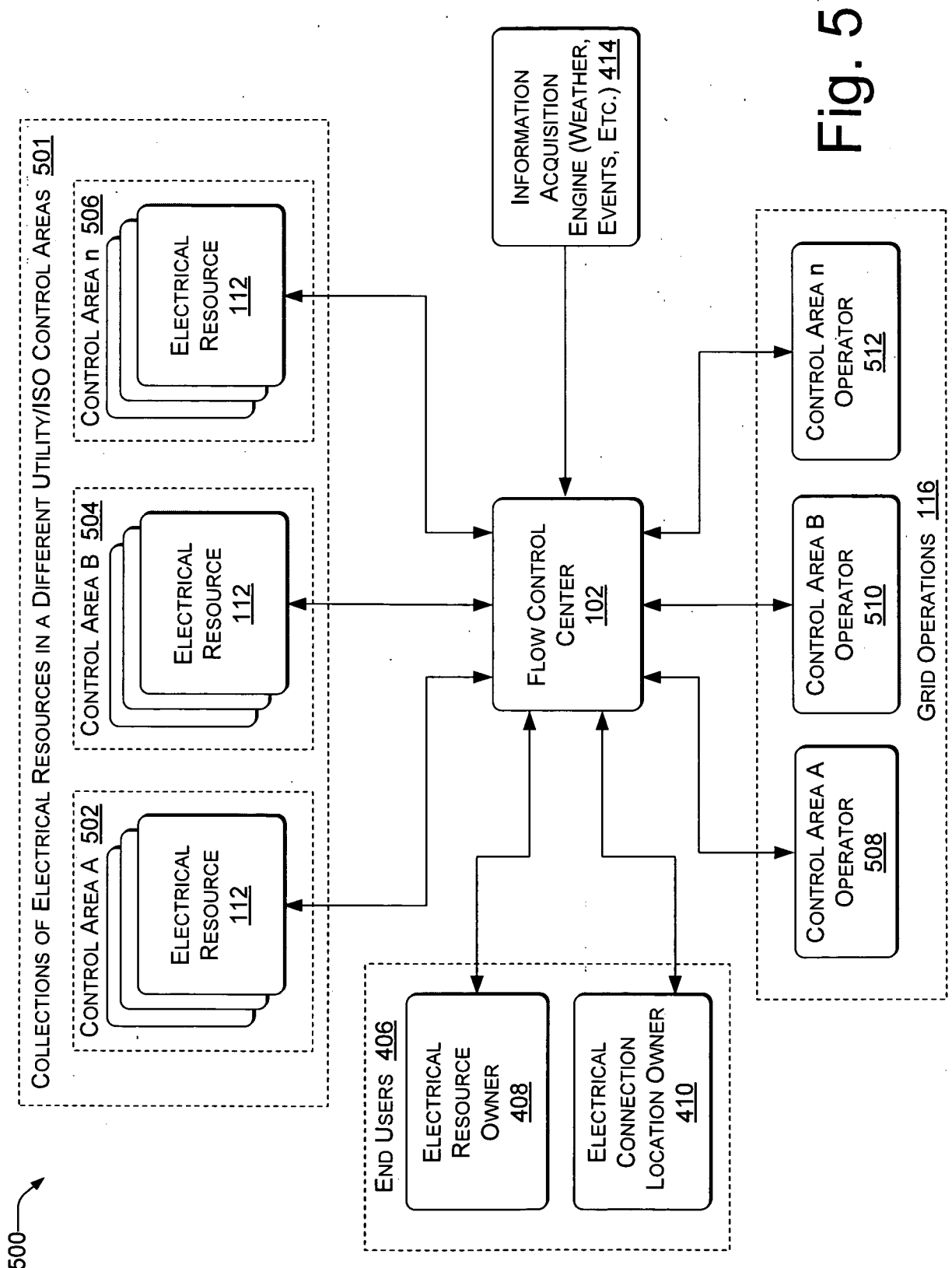

Fig. 5

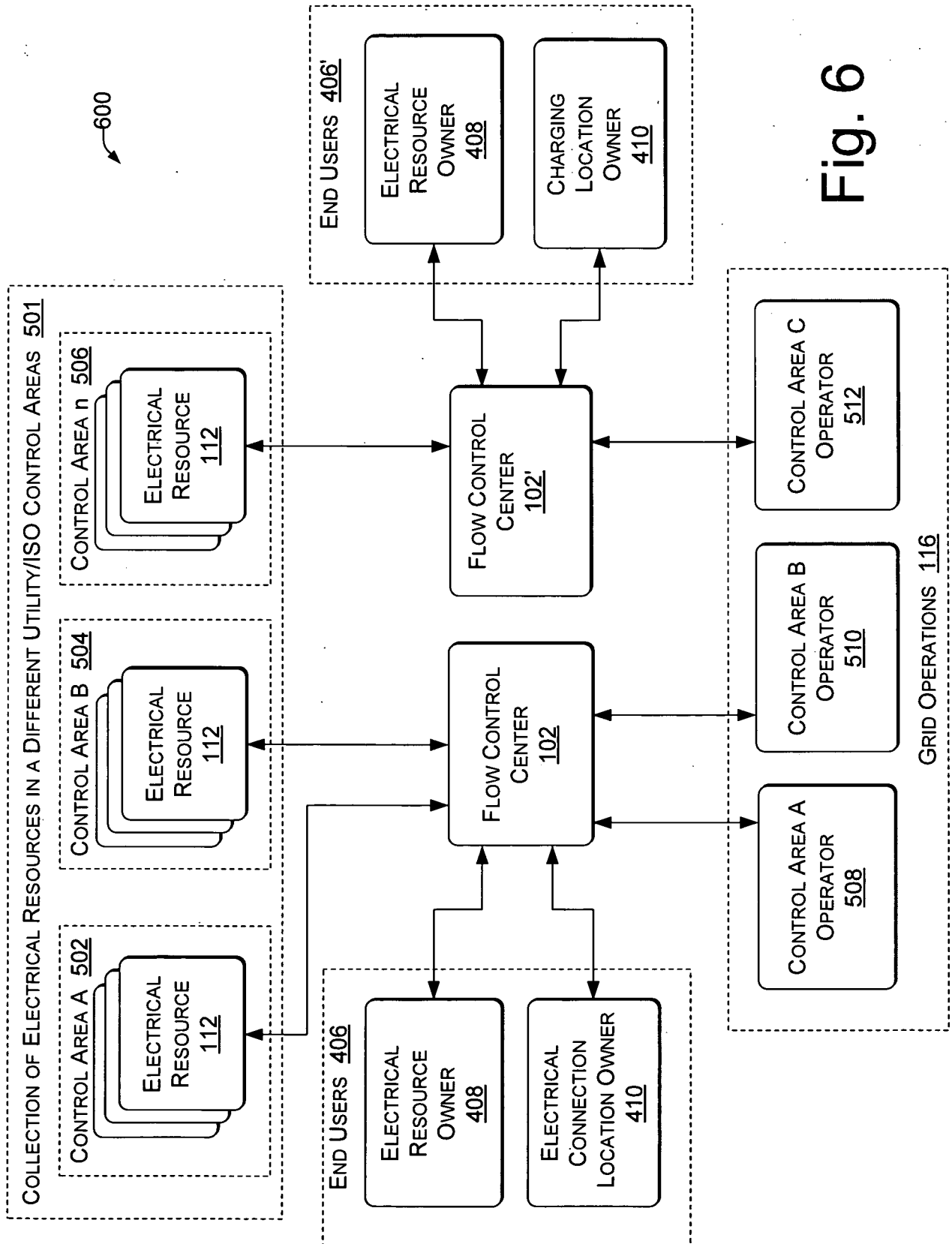

Fig. 6

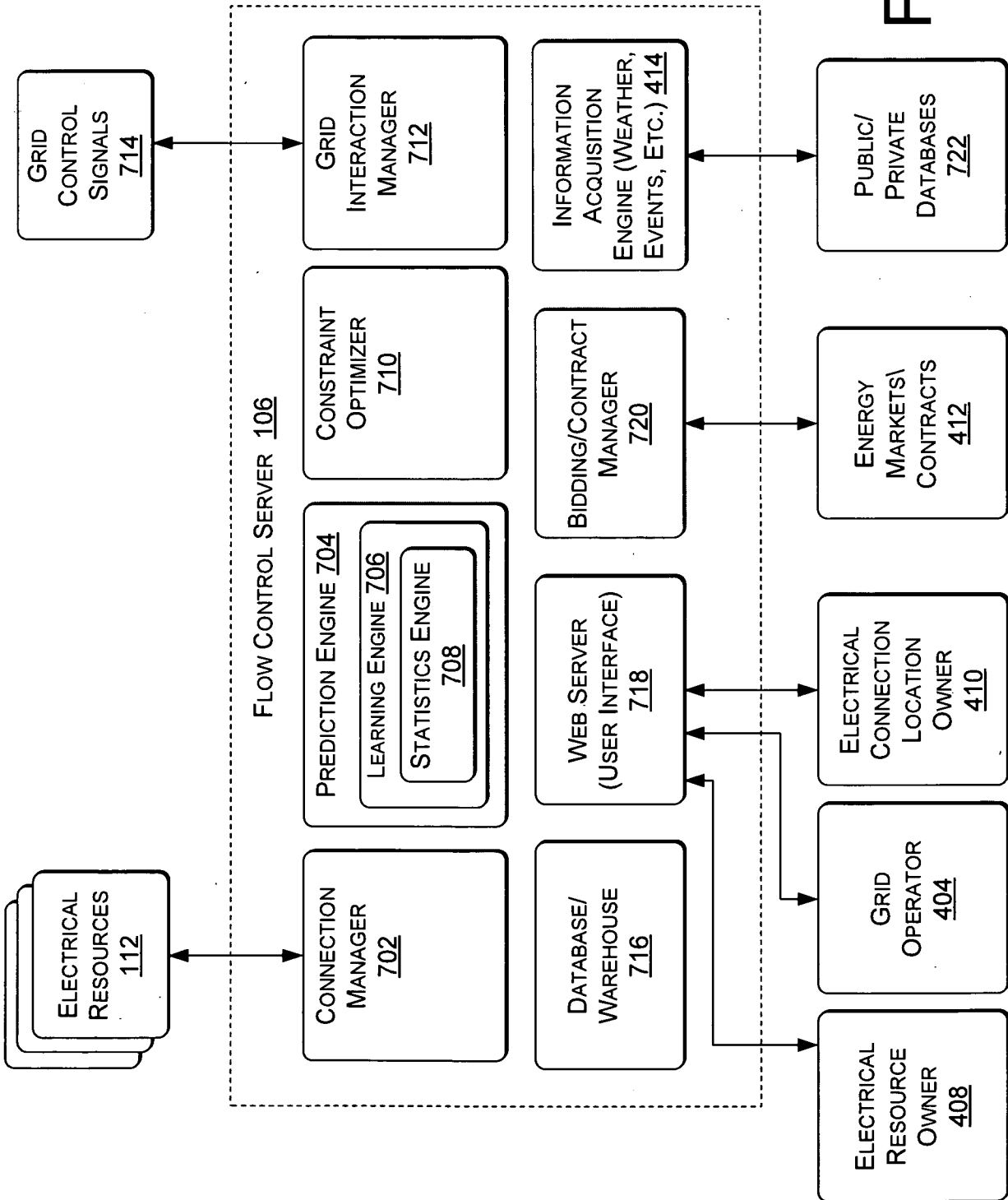

Fig. 7

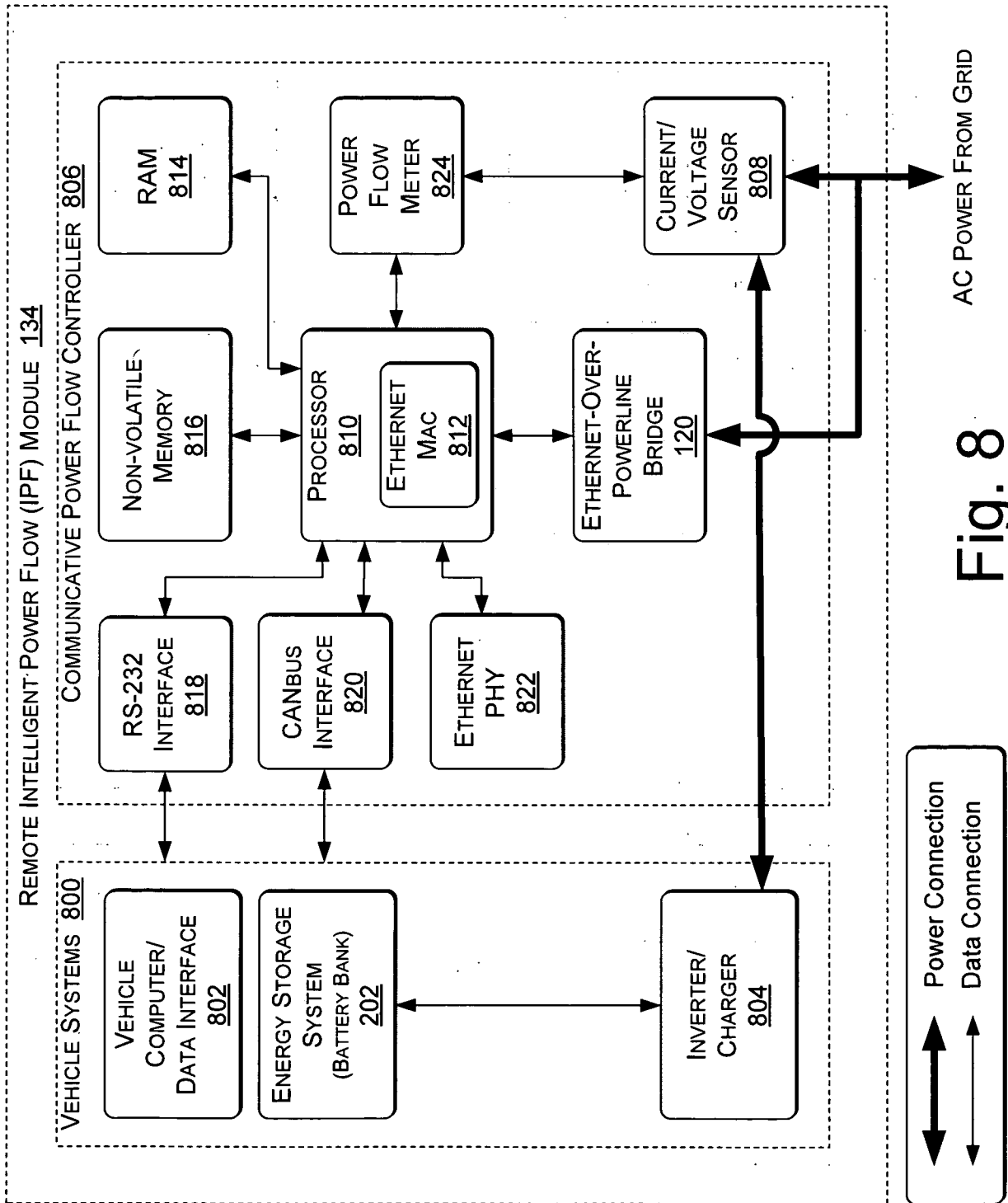

Fig. 8

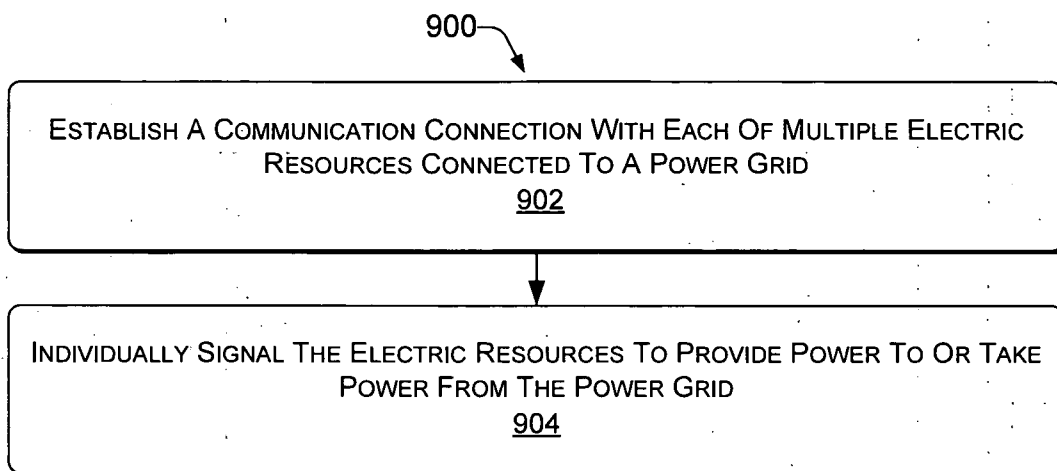

Fig. 9

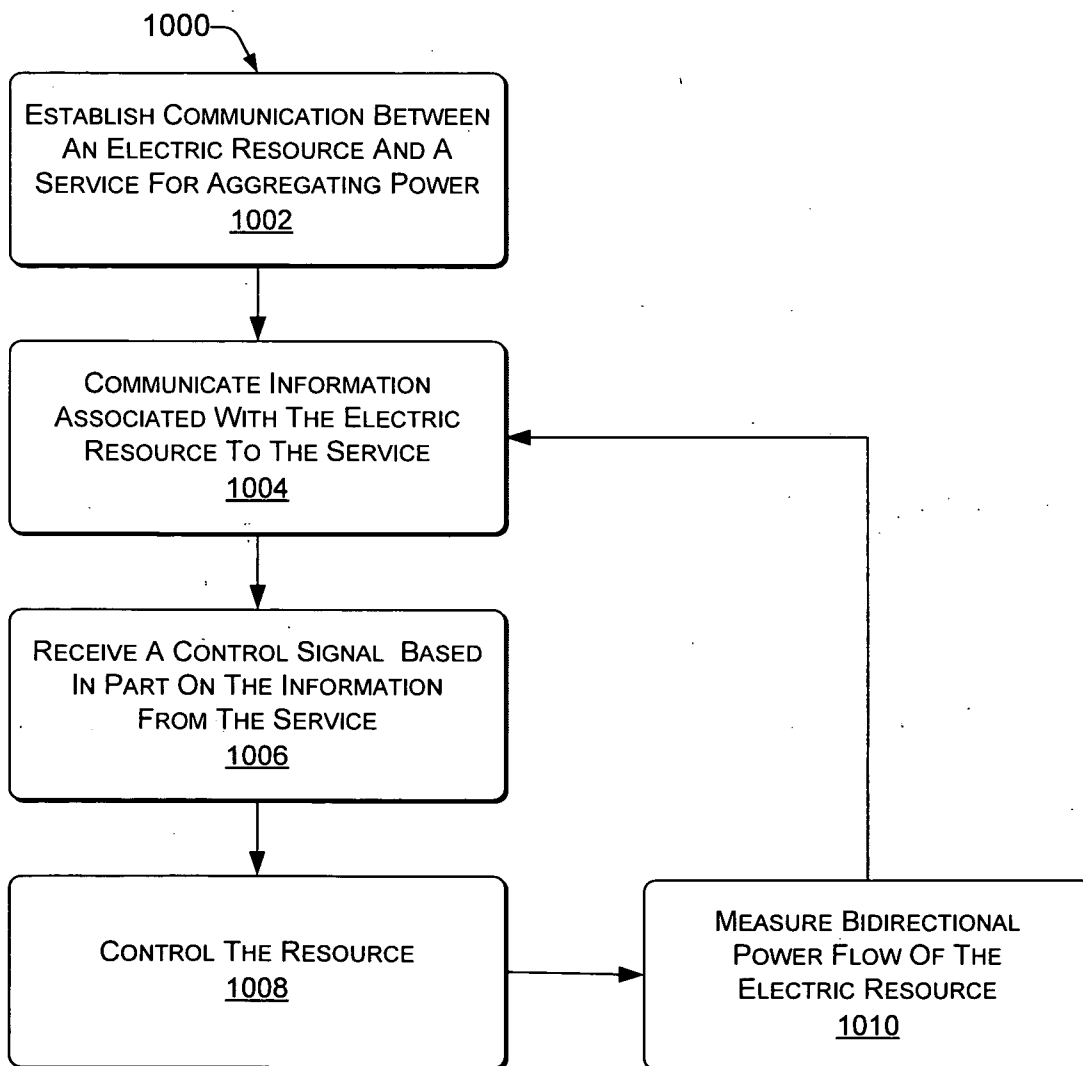

Fig. 10

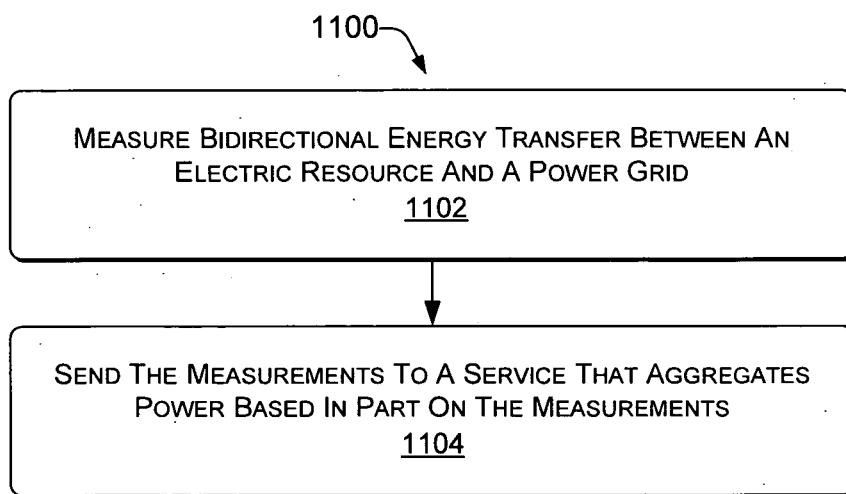

Fig. 11

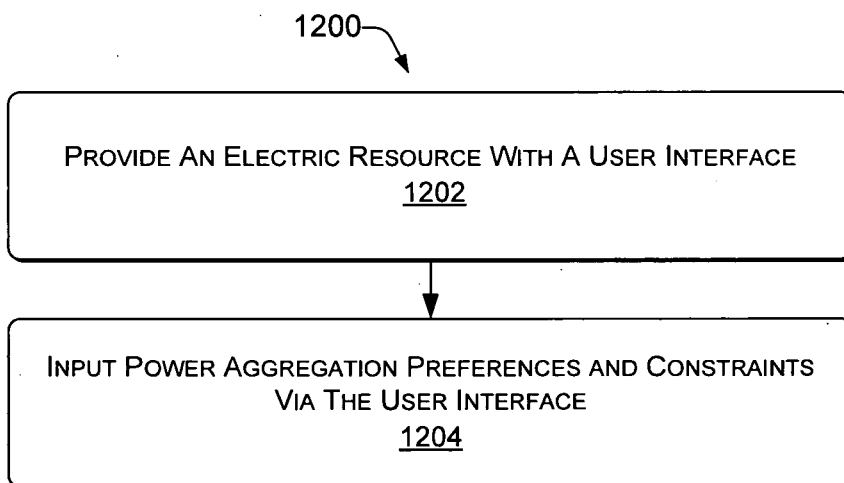

Fig. 12