

D. D. ROBINSON.  
Metal Punch and Shears.

No. 67,352.

Patented July 30, 1867.

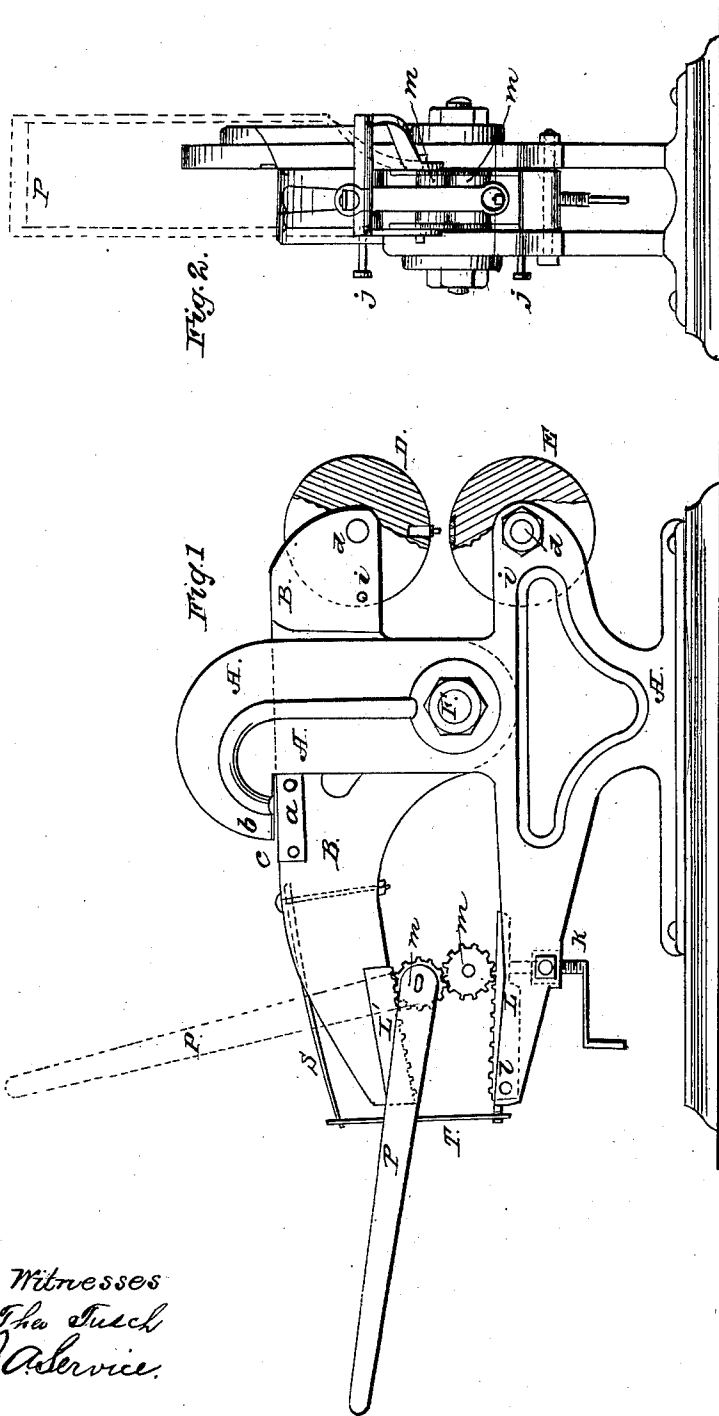

Witnesses  
E. H. Stueck  
J. A. Service.

Inventor  
D. D. Robinson  
per Munn & Co.  
Attorneys

# United States Patent Office.

D. D. ROBINSON, OF NILES, MICHIGAN.

Letters Patent No. 67,352, dated July 30, 1867.

## IMPROVED PUNCH AND SHEARS.

The Schedule referred to in these Letters Patent and making part of the same.

### TO ALL WHOM IT MAY CONCERN:

Be it known that I, D. D. ROBINSON, of Niles, in the county of Berrien, and State of Michigan, have invented a new and useful Improvement in Anti-Friction Punch and Shears; and I do hereby declare that the following is a full, clear, and exact description thereof, which will enable those skilled in the art to make and use the same, reference being had to the accompanying drawings, forming part of this specification.

My invention consists in so constructing a combined punch and shears that I am enabled to use a variety of punches and dies attached to their blocks or wheels, and ready for use when moved into position, and also in my arrangement of gears for keeping my traversing rollers in position upon my inclined planes, as I will herein describe. In the accompanying drawings—

Figure 1 represents a side elevation of my punch and shears.

Figure 2 is a view of the back end of the same.

Similar letters of reference indicate corresponding parts.

A represents the stand or body of punch and shears, to which the parts are attached. B is the lever or beam to which the punch and one portion of the shears are attached. C represents the shears. D is the punch-wheel. E is the die-wheel. The beam B is attached to the stand A by a strong pin, F, which has screw-nuts on the ends to keep it in place. This pin is the pivot or fulcrum upon which the lever-beam works, both for punching and shearing. One portion of the shears is attached to the beam, as seen at *a*. The other portion is attached to the stand, the top part of which projects for that purpose, as seen at *b*, the plate *b* being on the opposite side from that shown in the drawing. These plates or cutting parts of the shears are, of course, made of steel, and fastened by screw-bolts or rivets. The wheels D and E are disks of metal, which are rotated on their centres at *d d*. The wheel D is attached to the beam, and the wheel E to the stand. Around the peripheries of these wheels the punches and dies to fit them are arranged. Only one of each kind is shown in the drawing, but there may be as many as eight or more in each. There are holes in the sides of these wheels, which correspond with a hole for each wheel in the beam and in the stand. These holes are indicated in dotted lines by *i* in the beam and in the stand. In the wheels there is a hole for each punch and die, and they are so arranged that when a hole in the punch or die-wheel corresponds with the hole in the beam or stand, a pin (seen at *j*, fig. 2,) is inserted, when the punch and the die will correspond, and they are ready for use, the pins holding the wheels in place. The die-plates and punches are inserted in the usual manner, by pins or set-screws, as may be deemed best. It will be seen that by this arrangement the punches and dies may be changed with the least possible delay.

To operate the beam and do the work for either punching or shearing, I have rollers traversing inclined planes at the other end of the machine. The inclined plane L is governed in its position by the set-screw *k*; it is seen in dotted lines. It is pivoted to the stand A at *l*, and one end of it is raised or lowered as the screw *k* is turned up or down. The position of the inclined planes determines the throw of the other end of the lever-beam. *m m* are traversing rollers, the cutter edges of which form gear-pinions which work on racks on the edges of the inclined plane L. These pinions are seen in fig. 2. Racks corresponding with those on the inclined plane L are also attached to the lever-beam B, which forms the other inclined plane, marked L'. The two pinions work together, and the arrangement forms a double rack and pinion and a double inclined plane. One of these rollers is attached to the lever P rigidly; it may in fact be said that it forms the end of the lever. When the lever is raised or lowered the two rollers work together, being held in position by the cogs. The faces of these rollers work in contact with each other and in contact with the faces of the inclined planes. One roller, as before stated, is attached to the lever P, the other is loose and traverses the inclined plane as it is moved and controlled by the lever P.

The action of these rollers between the two inclined planes is similar to what the action of double cams would be in the same position, but in this case the inclined planes are forced apart without the friction of any rubbing surfaces. Although a great force can be transmitted by this arrangement to the punch or shears, the friction is reduced to a minimum.

Attached to the upper portion of the lever-beam B there is a spring, S, the outer end of which is connected with the inclined plane L by a link, T. When the punch or shears are in operation and the inclined planes are thrown apart by the power applied, the recoil of the spring brings them towards each other again whenever the

power ceases or intermits. It is the action of the spring that withdraws the punch from the metal when it has done its work.

I do not confine myself to the particular construction of all the parts of my machine, as herein described. I am aware that the punch and die-wheels may be held in position in other ways, and I am also aware that the punch may be operated in other ways besides with the lever P. I claim to use any equivalent device for either.

Having thus described my invention, what I claim as new, and desire to secure by Letters Patent, is—

1. The wheels D and E, with their punches and dies, all constructed, arranged, and operating substantially as described.

2. The stand A, having at one end the die-wheel E, and the rack-inclined plane L at the other, with the portion *b* of the shears supported about its middle, in combination with the spring-beam B, with the punch-wheel D at one end, the rack-inclined plane L' at the other, and bearing the portion *a* of the shears, the rollers *m m* being arranged therewith, and operating substantially as described for the purpose specified.

3. I claim the set-screw *k*, in combination with the adjustable inclined plane L and the geared rollers *m m*, substantially as described.

D. D. ROBINSON.

Witnesses:

EBENEZER McILVAINE,  
ORVILLE W. COOLIDGE.