



- (51) International Patent Classification:
D06F 39/08 (2006.01)
- (21) International Application Number:
PCT/EP2011/072543
- (22) International Filing Date:
13 December 2011 (13.12.2011)
- (25) Filing Language: English
- (26) Publication Language: English
- (30) Priority Data:
A 2010/11269 31 December 2010 (31.12.2010) TR
- (71) Applicant (for all designated States except US): **ARCELIK ANONIM SIRKETI** [TR/TR]; E5 Ankara Asfalti Uzeri, Tuzla, 34950 Istanbul (TR).
- (72) Inventors; and
- (75) Inventors/Applicants (for US only): **OCAK, Baris** [TR/TR]; E5 Ankara Asfalti Uzeri, Tuzla, 34950 Istanbul (TR). **OZKAHRAMAN, Hakan** [TR/TR]; E5 Ankara Asfalti Uzeri, Tuzla, 34950 Istanbul (TR). **TEZDUYAR, Latif** [TR/TR]; E5 Ankara Asfalti Uzeri, Tuzla, 34950 Istanbul (TR). **YILDIZ, Gokhan** [TR/TR]; E5 Ankara Asfalti Uzeri, Tuzla, 34950 Istanbul (TR).

- (81) Designated States (unless otherwise indicated, for every kind of national protection available): AE, AG, AL, AM, AO, AT, AU, AZ, BA, BB, BG, BH, BR, BW, BY, BZ, CA, CH, CL, CN, CO, CR, CU, CZ, DE, DK, DM, DO, DZ, EC, EE, EG, ES, FI, GB, GD, GE, GH, GM, GT, HN, HR, HU, ID, IL, IN, IS, JP, KE, KG, KM, KN, KP, KR, KZ, LA, LC, LK, LR, LS, LT, LU, LY, MA, MD, ME, MG, MK, MN, MW, MX, MY, MZ, NA, NG, NI, NO, NZ, OM, PE, PG, PH, PL, PT, QA, RO, RS, RU, RW, SC, SD, SE, SG, SK, SL, SM, ST, SV, SY, TH, TJ, TM, TN, TR, TT, TZ, UA, UG, US, UZ, VC, VN, ZA, ZM, ZW.
- (84) Designated States (unless otherwise indicated, for every kind of regional protection available): ARIPO (BW, GH, GM, KE, LR, LS, MW, MZ, NA, RW, SD, SL, SZ, TZ, UG, ZM, ZW), Eurasian (AM, AZ, BY, KG, KZ, MD, RU, TJ, TM), European (AL, AT, BE, BG, CH, CY, CZ, DE, DK, EE, ES, FI, FR, GB, GR, HR, HU, IE, IS, IT, LT, LU, LV, MC, MK, MT, NL, NO, PL, PT, RO, RS, SE, SI, SK, SM, TR), OAPI (BF, BJ, CF, CG, CI, CM, GA, GN, GQ, GW, ML, MR, NE, SN, TD, TG).

Published:

- without international search report and to be republished upon receipt of that report (Rule 48.2(g))

(54) Title: A WASHER WHICH DETECTS WATER OVERFLOW

Figure 1

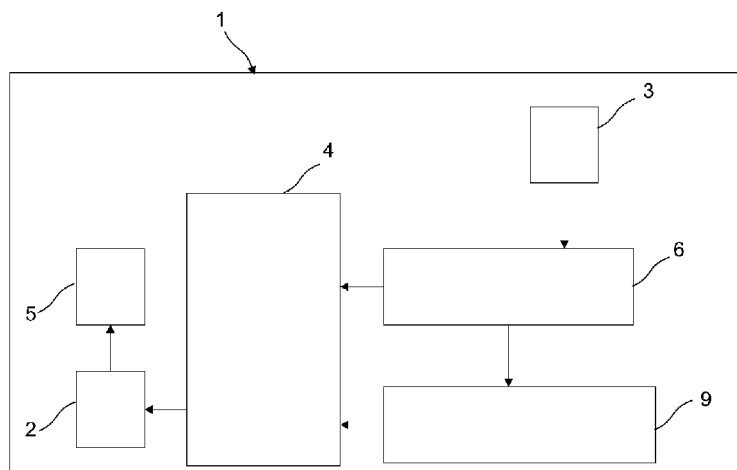

(57) Abstract: The present invention relates to a washer (1) comprising a door (2) which covers the opening through which the items to be washed are passed, a water intake valve (3) which provides the water required for the washing process, a control unit (4) which operates in two different modes, being the sleep mode and the operation mode, which evaluates the information received from the water overflow detection means (6) in the operation mode and which provides the large amount of water to be discharged by means of the discharge pump (5) upon detecting the critical amount of water that can cause overflow, a discharge pump (5) which provides the large amount of water that accumulates to be discharged, a water overflow detection means (6) which is active also when the control unit (4) is in the sleep mode and an awakening circuit (9) which provides the control unit (4) in the sleep mode to be awakened.

Description**A WASHER WHICH DETECTS WATER OVERFLOW**

- [0001] The present invention relates to a washer which detects water overflow.
- [0002] Studies are performed for decreasing the amount of energy consumption of washers, for example dishwashers and washing machines. Some of the said studies relate to the decreasing of the stand-by power consumption. Devices consume energy also in stand-by position. In the state of the art, the processor is operated in the sleep mode for providing lower stand-by power consumption. When in the sleep mode, the processor, in accordance with its properties, closes the external and internally derived clocks, timers, analog digital converters (ADC), serial communication blocks or similar units.
- [0003] When the processor is in the sleep mode, the information received from the sensors disposed in the washer cannot be evaluated by the processor. Thus, when the processor is in the sleep mode, the large amount of water, which is received into the washer due to a mechanical malfunction that occurs in the water intake valve of the washer, cannot be detected and necessary safety actions such as the operation of the discharge pump cannot be performed. Consequently, the water overflowing from the washer causes safety problems.
- [0004] The aim of the present invention is the realization of a washer which detects the amount of water at the critical level, which can cause overflow, and provides the water to be discharged.
- [0005] The control unit disposed in the washer realized in order to attain the aim of the present invention, explicated in the claims, has two different operation modes, being the sleep mode and the operation mode. When the washer is in the stand-by position, the control unit stays in the sleep mode for providing saving of electricity. When the user presses the start button of the washer or performs the functions required for the operation of the washer, the control unit changes to the operation mode by awakening from the sleep mode and provides the washer to be operated. When the operation of the washer is completed, the control unit changes to the sleep mode again.

- [0006] The water overflow detection means disposed in the washer of the present invention is active also when the control unit is in the sleep mode.
- [0007] The awakening circuit evaluates the signals received from the water overflow detection means. The awakening circuit sends signal to the control unit as a result of the said evaluation. If the control unit is in the sleep mode, it awakens as a result of the signal received from the awakening circuit.
- [0008] In an embodiment of the present invention, the control unit locks the door of the washer and operates the discharge pump through the door. As a result of the operation of the discharge pump, the large amount of water that accumulates in the washer is discharged from the washer.
- [0009] In an embodiment of the washer of the present invention, an electrical/electronic filter is disposed between the awakening circuit and the water overflow detection means.
- [0010] In an embodiment of the present invention, the water overflow detection means comprises water counter and/or water level detector. In the said embodiment, while the water counter measures the amount of the water coming from the water intake valve, the water level detector measures the level of the water in the washer.
- [0011] In an embodiment of the present invention, the filter is disposed between the water level detector and the awakening circuit. In the said embodiment, while the information received from the water level detector reaches the awakening circuit, the information received from the water level gauge reaches the filter. The frequency of the signal which is received from the water level detector when the water level reaches a critical value is different from the frequency of the signal which is received from the water level detector when the water level has a lower value. The filter detects the frequency of the signal received from the water level detector when the water level reaches a critical value and while delivering the said signal to the awakening circuit, prevents the other signals with lower frequency from reaching the awakening circuit. By means of the said filtering process, water in the washer which can be in small amounts is prevented from being detected as water level error.

- [0012] In an embodiment of the present invention, the awakening circuit is an “AND” gate. In this embodiment, when both the information received from the water counter and the information received from the water level detector are above a critical level, the awakening circuit sends signal to the control unit for awakening the control unit.
- [0013] In another embodiment of the present invention, the awakening circuit is an “OR” gate. In the said embodiment, when one of the two informations received from the water counter or from the water level detector is above a critical level, the awakening circuit sends signal to the control unit for awakening the control unit.
- [0014] When the washer is in the stand-by position, the control unit is in the sleep mode; however, since the washer is connected to the mains, the water overflow detection means and the awakening circuit are active and produce the respective feedbacks.
- [0015] A washer realized in order to attain the aim of this invention is illustrated in the attached figures, where :
- [0016] Figure 1 – is the schematic view of the preferred embodiment of a washer.
- [0017] Figure 2 – is the schematic view of an embodiment of a washer.
- [0018] Figure 3 – is the schematic view of yet another embodiment of a washer.
- [0019] Figure 4 – is the schematic view of another embodiment of a washer.
- [0020] The elements illustrated in the figures are numbered as follows:
1. Washer
 2. Door
 3. Water intake valve
 4. Control unit
 5. Discharge pump
 6. Water overflow detection means
 7. Water counter
 8. Water level detector
 9. Awakening circuit
 10. Filter
- [0021] The washer (1) of the present invention comprises at least one door (2), at least one water intake valve (3), at least one control unit (4) which

operates in two different modes, being the sleep mode and the operation mode, at least one discharge pump (5) which provides the water to be discharged and at least one water overflow detection means (6) which is active also when the control unit (4) is in the sleep mode (Figure 1).

- [0022] When the control unit (4) is in the operation mode, it evaluates the information received from the water overflow detection means (6). As a result of the said evaluation, the control unit (4) operates the discharge pump (5) upon detecting the presence of a critical amount of water. As a result of the operation of the discharge pump (5), the large amount of water that accumulates in the washer (1) is discharged from the washer (1).
- [0023] The washer (1) comprises at least one awakening circuit (9) which is actuated by the signal received from the water overflow detection means (6), which sends signal to the control unit (4) and provides the control unit (4) in the sleep mode to be awakened.
- [0024] When the washer (1) is in the stand-by position, the control unit (4) is in the sleep mode; however, since the washer (1) is connected to the mains, the water overflow detection means (6) and the awakening circuit (9) are energized and produce the respective feedbacks. When in the sleep mode, the control unit (4) receives the signals coming from the ends to which the awakening circuit (9) is connected and changes to the operation mode.
- [0025] While waiting in the stand-by position, the washer (1) is connected to the mains. For providing saving of electricity in the said stand-by position, the control unit (4) is in the sleep mode. When the washer (1) is operated, the control unit (4) changes from the sleep mode to the operation mode and performs the functions required for the operation of the washer (1). When the operation of the washer (1) is completed, the control unit (4) automatically changes to the sleep mode again.
- [0026] In an embodiment of the present invention, the awakening circuit (9) detects the large amount of water in the washer (1) by evaluating the information received from the water overflow detection means (6) and as a result of the said detection, sends signal to the control unit (4) for

awakening the control unit (4). If the control unit (4) is in the sleep mode, it awakens as a result of the signal received from the awakening circuit (9) and locks the door (2) of the washer (1) and operates the discharge pump (5) through the door (2). As a result of the operation of the discharge pump (5), the large amount of water that accumulates in the washer (1) is discharged from the washer (1). After the large amount of water is discharged, the control unit (4) automatically changes to the sleep mode again.

- [0027] In an embodiment of the present invention, the water overflow detection means (6) comprises at least one water counter (7) (Figure 2). The water counter (7) measures the amount of the water that fills in the washer (1) in unit time.
- [0028] In an embodiment of the present invention, the water overflow detection means (6) comprises at least one water level detector (8) (Figure 3). The water level detector (8) measures the level of the water that accumulates.
- [0029] When the warning signal relating to the water level reaches from the water counter (7) and/or water level detector (8) to the awakening circuit (9), the awakening circuit (9) actuates and changes the control unit (4) to the operation mode and the control unit (4) provides the said large amount of water to be discharged from the washer (1).
- [0030] In an embodiment of the present invention, the washer (1) comprises at least one electrical/electronic filter (10) disposed between the awakening circuit (9) and the water overflow detection means (6). The filter (10) detects the frequency of the signal received from the water overflow detection means (6) when the water level reaches a critical value and while delivering the said signal to the awakening circuit (9), prevents the other signals with lower frequency from reaching the awakening circuit (9).
- [0031] In a variation of this embodiment, the filter (10) is disposed between the awakening circuit (9) and the water level detector (8). In the said embodiment, while the information received from the water counter (7) reaches the awakening circuit (9), the information received from the water level detector (8) reaches the filter (10). The frequency of the signal which is received from the water level detector (8) when the water level reaches

a critical value, is different from the frequency of the signal, which is received from the water level detector (8) when the water level has a lower value. The filter (10) detects the frequency of the signal received from the water level detector (8) when the water level reaches a critical value and while delivering the said signal to the awakening circuit (9), prevents the other signals with lower frequency from reaching the awakening circuit (9). By means of the said filtering process, water in the washer (1) which can be in small amounts is prevented from being detected as water level error.

- [0032] In an embodiment of the present invention, the awakening circuit (9) is an “AND” gate. In the said embodiment, when both the information received from the water counter (7) and the information received from the water level detector (8) are above a critical level, the awakening circuit (9) sends signal to the control unit (4) for awakening the control unit (4).
- [0033] In another embodiment of the present invention, the awakening circuit (9) is an “OR” gate. In the said embodiment, when one of the two informations received from the water counter (7) or from the water level detector (8) is above a critical level, the awakening circuit (9) sends signal to the control unit (4) for awakening the control unit (4).
- [0034] In an embodiment of the present invention, the washer (1) of the present invention is a washing machine
- [0035] In another embodiment of the present invention, the washer (1) of the present invention is a dishwasher.
- [0036] In the washer (1) of the present invention, the large amount of water that fills in the washer (1) due to a malfunction that might occur is detected by the water overflow detection means (6) even when the control unit (4) is in the sleep mode, er (1).
- [0037] It is to be understood that the present invention is not limited by the embodiments disclosed above and a person skilled in the art can easily introduce different embodiments. These should be considered within the scope of the protection postulated by the claims of the present invention.

Claims

1. A washer (1) **comprising** at least one door (2), at least one water intake valve (3), at least one control unit (4) which operates in two different modes, being the sleep mode and the operation mode and at least one discharge pump (5) which provides the water to be discharged, **characterized by** at least one water overflow detection means (6) which is active also when the control unit (4) is in the sleep mode and at least one awakening circuit (9) which is actuated by the signal received from the water overflow detection means (6), which sends signal to the control unit (4) and provides the control unit (4) in the sleep mode to be awakened.
2. A washer (1) as in Claim 1, **characterized by** the water overflow detection means (6) comprising at least one water counter (7).
3. A washer (1) as in Claim 1 or 2, **characterized by** the water overflow detection means (6) comprising at least one water level detector (8).
4. A washer (1) as in any one of the above claims, **characterized by** at least one electrical/electronic filter (10) disposed between the awakening circuit (9) and the water overflow detection means (6).
5. A washer (1) as in Claim 3, **characterized by** at least one electrical/electronic filter (10) disposed between the awakening circuit (9) and the water level detector (8).
6. A washer (1) as in Claim 2 or 3, **characterized by** the awakening circuit (9) which is an "AND" gate and which sends signal to the control unit (4) for awakening the control unit (4) when both the information received from the water counter (7) and the information received from the water level detector (8) are above a critical level.
7. A washer (1) as in Claim 2 or 3, **characterized by** the awakening circuit (9) which is an "OR" gate and which sends signal to the control unit (4) for awakening the control unit (4) when one of the two informations received from the water counter (7) or from the water level detector (8) is above a critical level.
8. A washer (1) as in any one of the above claims, which is a dishwasher.
9. A washer (1) as in any one of the Claims 1 to 7, which is a washing machine.

Figure 1

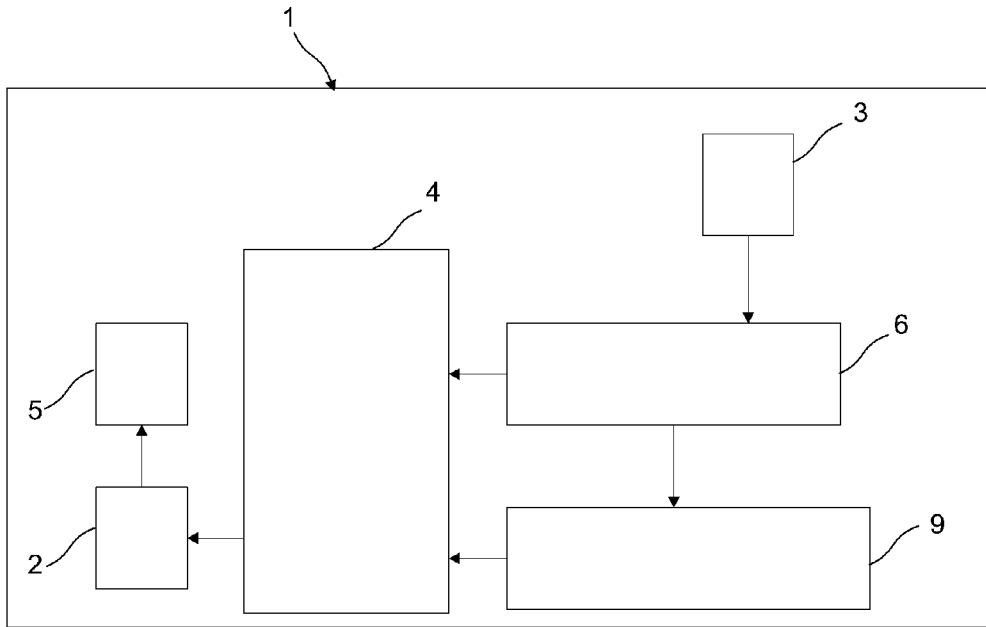

Figure 2

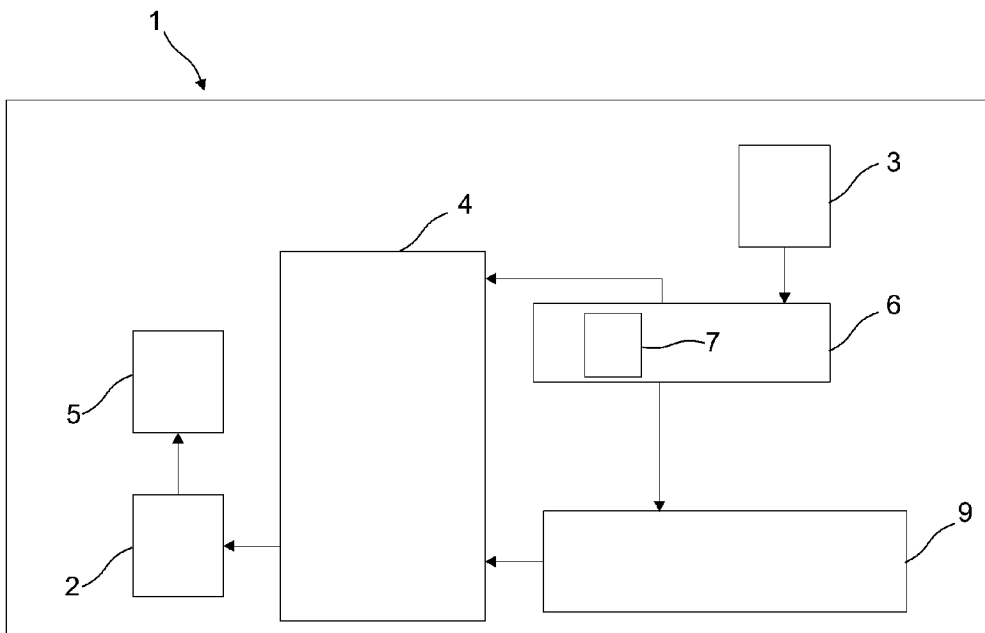

Figure 3

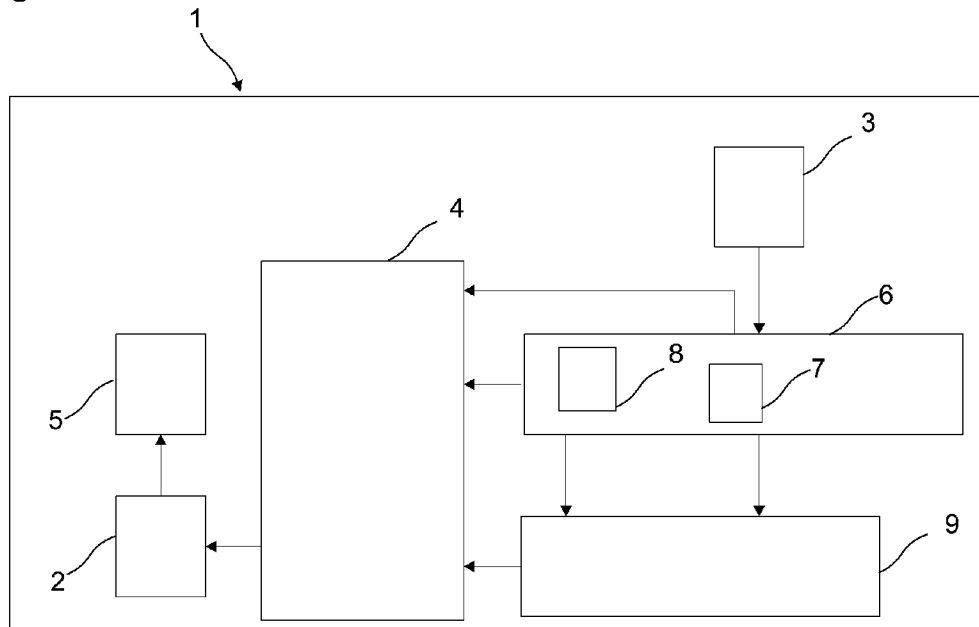

Figure 4

