

J. H. H. BENNETT.

Gate.

No. 30,460.

Patented Oct. 23, 1860.

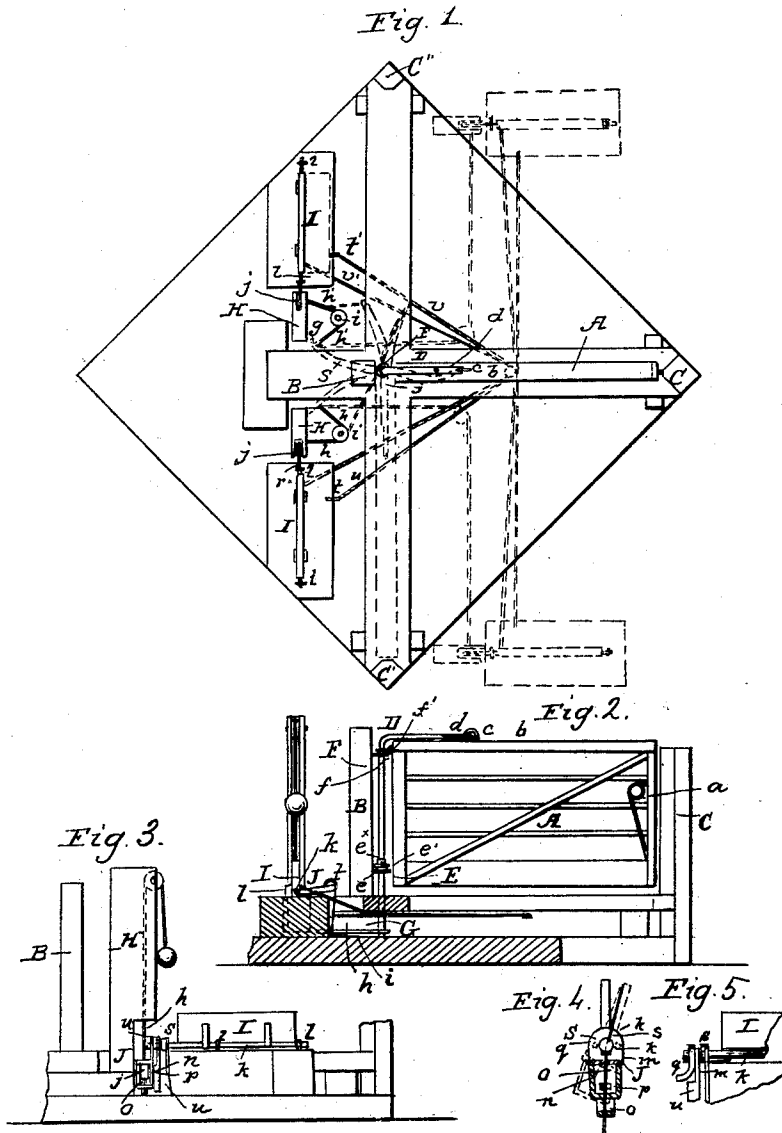

Witnesses:
W. Loomis
R. S. Spuman.

Inventor:
J. H. H. Bennett
per [Signature]
Attorney.

UNITED STATES PATENT OFFICE.

J. H. H. BENNETT, OF HUNTS HOLLOW, NEW YORK.

GATE.

Specification of Letters Patent No. 30,460, dated October 23, 1860.

To all whom it may concern:

Be it known that I, J. H. H. BENNETT, of Hunts Hollow, in the county of Livingston and State of New York, have invented a new and Improved Gate; and I do hereby declare that the following is a full, clear, and exact description of the same, reference being had to the accompanying drawings, forming part of this specification, in which—

Figure 1, represents a plan or top view of my invention. Fig. 2, is a longitudinal vertical section of the same. Fig. 3 is a side elevation of the same. Fig. 4 is a transverse vertical section of the trap, which forms a portion of my invention in an enlarged scale. Fig. 5, is a side elevation of the same.

Similar letters of reference in all the figures indicate corresponding parts.

To enable those skilled in the art to make and use my invention I will proceed to describe its construction and operation with reference to the drawing.

The gate A, is hinged to the post B, and as it closes the roadway the spring latch *a*, on the same catches into a suitable recess in the gate post C. Two similar posts C', C'', arranged in line or nearly so with the post B, serve to retain the gate when the same is opened. The gate is operated by the bent lever D, which passes through the hinges of the gate and which is fastened to the top rail *b*, by means of a staple *c*, and link *d*. The lower hinge E, of the gate consists of two loops *e*, *e'*, the loop *e*, being rigidly fastened to the post B, and being provided with a small projecting tube *e**, which forms the guide for the upright portion of the lever D, and for the loop *e'*, which is firmly attached to the back edge of the gate. The upper hinge F, of the gate consists also of two loops *f*, *f'*, and the loop *f*, is rigidly secured to the post B, whereas the loop *f'*, is attached to the back edge of the gate by means of a staple *f**, so that on turning the lever D, in either direction the gate is allowed to assume an inclined position, its front part being raised and the upper part of the same being thrown out over the lower part, so that the latch is disengaged and the gate is caused to swing in one direction or in the other as the case may be.

The foot of the lever D, rests in a socket under the gate and it is operated by means of an arm G, which is rigidly attached to the lower part of said lever, and which is provided with two loops *g*, *g'*, to receive

the ends of the cords *h*, *h'*. These cords pass around pulleys *i*, *i'*, and over pulleys *j*, *j'*, up to the cord posts H, H', and said pulleys are arranged in such relation to the arm G, and to the lever D, that a strain exerted on either one of the cords *h*, *h'*, causes the gate to swing in the opposite direction or from the person approaching the gate. It must be remarked that the proper position of these cord posts would be as indicated by blue lines in Fig. 1, and they have only been represented in the position in which they are shown in the drawing in order to save room. When arranged as shown in red outlines a person approaching the gate can reach the cords and by pulling them he or she can open the gate ready to pass through and by pulling the cord on the other post the gate is closed.

By connecting the cords with the hinged plates I, I', the gate can also be operated by the wheel or wheels of an approaching vehicle, said plates are hinged to oscillating shafts *k*, *k'*, which are secured to the ground by means of loops *l*, (see Fig. 3) on the sides of the cord posts H, H', and firmly secured to their ends nearest to the cord posts are the traps J, which serve to arrest the cords on being turned with the plates I, I', and which release said cords again as soon as the gate has been opened or closed.

The construction of these traps will be best understood by referring to Figs. 4, and 5, in the drawing. They consist of four plates *m*, *n*, *o*, and *p*. The upper plate *m*, is bent at right angles and it is secured to the shaft *k*, or *k'*, by means of a spring *q*, which is firmly attached to the under side of said shaft and which catches in a notch *r*, in the upright portion of the plate *m*. The plate *n*, is bent in the form of a staple and it is rigidly secured to the horizontal portion of the plate *m*. The plate *o*, on the other hand is attached loosely to the plate *m*, and firmly secured to the plate *o*, is the plate *p*, above or within the plate *n*, as clearly shown in Fig. 4. Each of the plates is provided with a suitable hole just large enough for the cord *h*, or *h'* to pass. On turning the shaft *k*, or *k'*, in one direction or in the other the plates *m*, and *n*, are caused to turn also, whereas the plates *o*, and *p* have a tendency to retain their vertical position by the strain of the cord and the several plates and the cord assume a position as shown in red outlines in Fig. 4. In this position the cord is

held firmly between the plates *m, n, o, p*, and the motion of the hinged plates *I, I'*, caused by the wheel or wheels of a vehicle passing over it is imparted to the gate and the latter is caused to swing open or to close as the case may be. As soon as the plates *I, I'*, are turned down completely, the springs *q*, by coming in contact with the rollers *s*, on the sides of the shafts *k, k'*, are released from the notches *r*, in the plates *m*, and the traps *J*, are allowed to fall back to their original position independent from the plates *I, I'*, which latter are caught by the spring hooks *t, t'*, and retained down until the wheel or wheels of the vehicle by striking the plate on the opposite side of the gate release said spring hook and allow the plate in question to follow the action of a balance weight *u*, and to resume its original upright position. To effect this the plate *I*, connects by means of a cord *v*, with the spring hook *t'*, on the other side of the gate and near to the plate *I'*, and the plate *I'*, connects by a cord *v'*, with the spring hook *t*, near to the plate *I*.

It will be noticed that the plates *I, I'*, take the places of the cranks generally employed for the same purpose, and in places, where the correct action of these plates is liable to be interfered with by snow, I substitute the cranks for the plates but I retain all the other parts of my device and the operation will be precisely the same.

With my gate all the parts required for operating the gate are underground or out of the way its operation is sure and easy and it is so constructed, that it cannot easily get out of order.

Having thus fully described my invention, what I claim as new, and desire to secure by Letters Patent, is—

The arrangement of the lever *D*, with the hinges *E, E*, gate *A*, post *B*, arm *G*, cords *h, h*, pulleys *i, i, j, j*, posts *H*, shafts *k, k*, traps *J*, and plates *I, I*, all as herein set forth and described for the purposes specified.

J. H. H. BENNETT.

Witnesses:

E. S. BENNETT,
M. E. BENNETT.