



(86) Date de dépôt PCT/PCT Filing Date: 2014/01/31
 (87) Date publication PCT/PCT Publication Date: 2014/08/07
 (85) Entrée phase nationale/National Entry: 2015/07/31
 (86) N° demande PCT/PCT Application No.: US 2014/013995
 (87) N° publication PCT/PCT Publication No.: 2014/120996
 (30) Priorités/Priorities: 2013/02/01 (US13/756,716);
 2013/10/24 (US14/062,025)

(51) Cl.Int./Int.Cl. *F16K 17/28* (2006.01),
F16K 17/34 (2006.01)
 (71) Demandeur/Applicant:
 QUICK FITTING, INC., US
 (72) Inventeurs/Inventors:
 CROMPTON, DAVID, US;
 DIAS, LIBARDO, US
 (74) Agent: OSLER, HOSKIN & HARCOURT LLP

(54) Titre : ENSEMBLE CLAPET ANTIRETOUR DE DEBIT ET PROCEDE
 (54) Title: FLOW CHECK VALVE ASSEMBLY AND METHOD

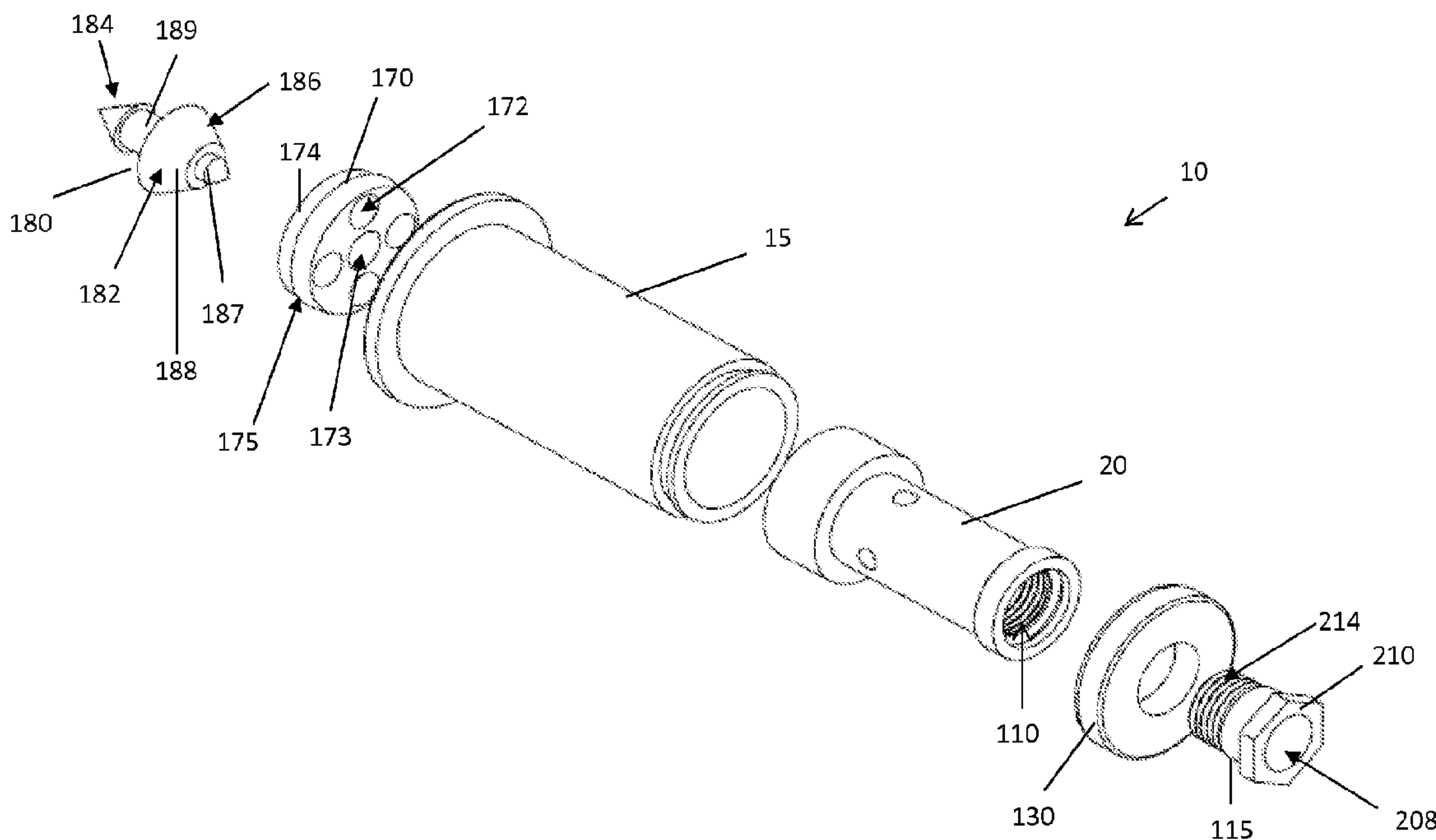

Fig. 1

(57) Abrégé/Abstract:

The present invention provides, in part, a valve assembly and method that maintains balance of flow to pressure in fluid and gas piping system applications. In one embodiment, 5 the present invention includes a main body component adapted to retain a chamber body component, a fluid control plate and seal, and a chamber cap. The chamber body component is slidably maintained within the main body component. A resilient gland member is securably attachable to one end of the main body component and the chamber body component, and acts as a seal and a memory for returning the chamber body component to a 10 standard operating position upon fluid pressure environment shifting the chamber body component towards a shut off position.

(12) INTERNATIONAL APPLICATION PUBLISHED UNDER THE PATENT COOPERATION TREATY (PCT)

(19) World Intellectual Property
Organization
International Bureau(10) International Publication Number
WO 2014/120996 A1(43) International Publication Date
7 August 2014 (07.08.2014)

(51) International Patent Classification:

F16K 17/34 (2006.01)

(21) International Application Number:

PCT/US2014/013995

(22) International Filing Date:

31 January 2014 (31.01.2014)

(25) Filing Language:

English

(26) Publication Language:

English

(30) Priority Data:

13/756,716	1 February 2013 (01.02.2013)	US
14/062,025	24 October 2013 (24.10.2013)	US

(71) Applicant: **QUICK FITTING, INC.** [US/US]; Quick Fitting, Inc., 30 Plan Way, Warwick, Rhode Island 02886 (US).(72) Inventors: **CROMPTON, David**; David B. Crompton, 55 Wampanoag Lane, Tiverton, Rhode Island 02878 (US).
DIAS, Libardo; Libardo Ochoa Dias, 18 Orchard Street, Pawtucket, Rhode Island 02860 (US).(74) Agent: **BERGERT, Thomas**; Thomas F. Bergert, Williams Mullen, PC, 321 East Main Street, Suite 400, Charlottesville, Virginia 22902 (US).

(81) Designated States (unless otherwise indicated, for every kind of national protection available): AE, AG, AL, AM,

AO, AT, AU, AZ, BA, BB, BG, BH, BN, BR, BW, BY, BZ, CA, CH, CL, CN, CO, CR, CU, CZ, DE, DK, DM, DO, DZ, EC, EE, EG, ES, FI, GB, GD, GE, GH, GM, GT, HN, HR, HU, ID, IL, IN, IR, IS, JP, KE, KG, KN, KP, KR, KZ, LA, LC, LK, LR, LS, LT, LU, LY, MA, MD, ME, MG, MK, MN, MW, MX, MY, MZ, NA, NG, NI, NO, NZ, OM, PA, PE, PG, PH, PL, PT, QA, RO, RS, RU, RW, SA, SC, SD, SE, SG, SK, SL, SM, ST, SV, SY, TH, TJ, TM, TN, TR, TT, TZ, UA, UG, US, UZ, VC, VN, ZA, ZM, ZW.

(84) Designated States (unless otherwise indicated, for every kind of regional protection available): ARIPO (BW, GH, GM, KE, LR, LS, MW, MZ, NA, RW, SD, SL, SZ, TZ, UG, ZM, ZW), Eurasian (AM, AZ, BY, KG, KZ, RU, TJ, TM), European (AL, AT, BE, BG, CH, CY, CZ, DE, DK, EE, ES, FI, FR, GB, GR, HR, HU, IE, IS, IT, LT, LU, LV, MC, MK, MT, NL, NO, PL, PT, RO, RS, SE, SI, SK, SM, TR), OAPI (BF, BJ, CF, CG, CI, CM, GA, GN, GQ, GW, KM, ML, MR, NE, SN, TD, TG).

Declarations under Rule 4.17:

- as to applicant's entitlement to apply for and be granted a patent (Rule 4.17(ii))
- as to the applicant's entitlement to claim the priority of the earlier application (Rule 4.17(iii))

Published:

- with international search report (Art. 21(3))

(54) Title: FLOW CHECK VALVE ASSEMBLY AND METHOD

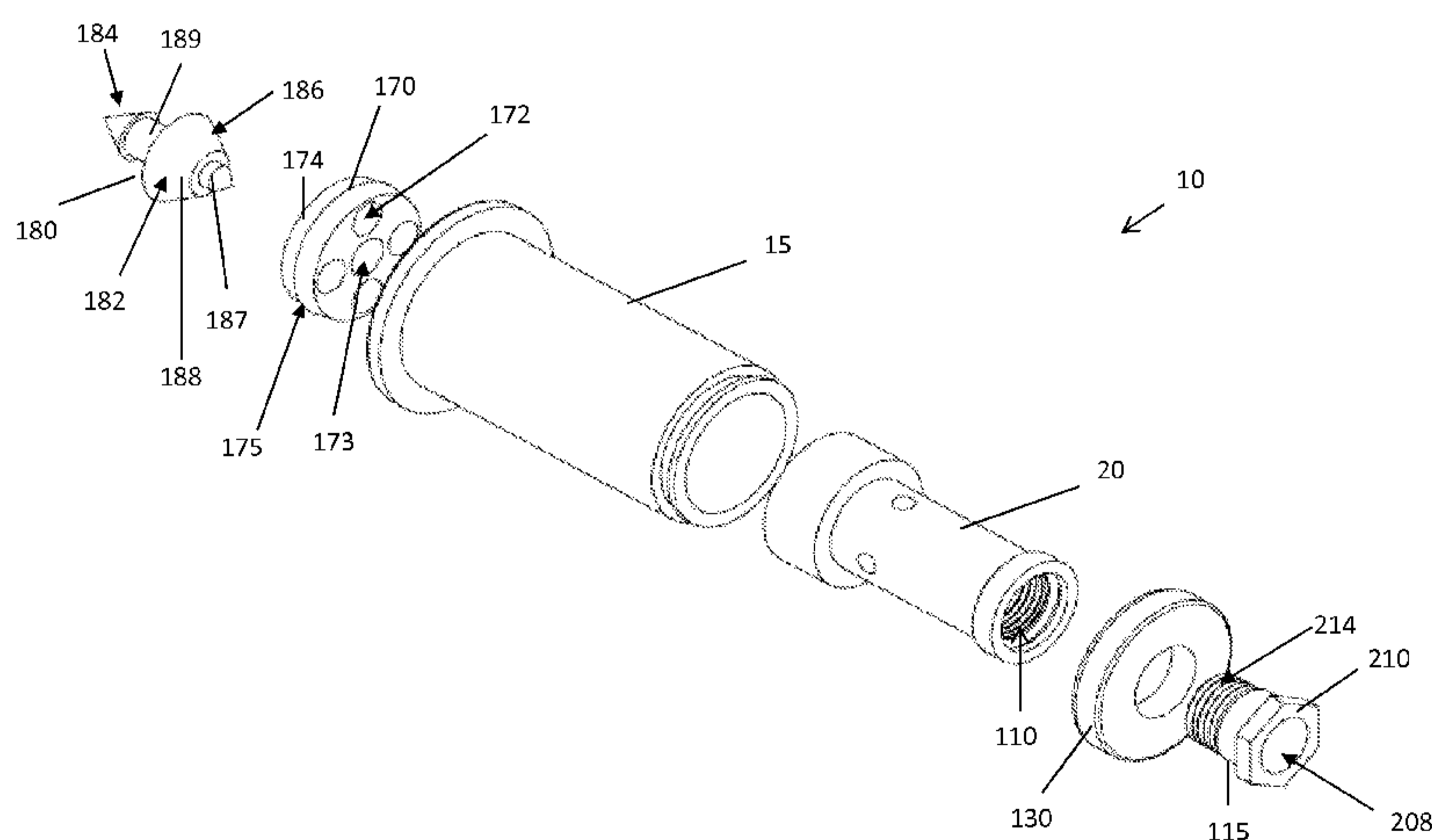

Fig. 1

(57) Abstract: The present invention provides, in part, a valve assembly and method that maintains balance of flow to pressure in fluid and gas piping system applications. In one embodiment, 5 the present invention includes a main body component adapted to retain a chamber body component, a fluid control plate and seal, and a chamber cap. The chamber body component is slidably maintained within the main body component. A resilient gland member is securably attachable to one end of the main body component and the chamber body component, and acts as a seal and a memory for returning the chamber body component to a 10 standard operating position upon fluid pressure environment shifting the chamber body component towards a shut off position.

WO 2014/120996 A1

FLOW CHECK VALVE ASSEMBLY AND METHOD

TECHNICAL FIELD

The present invention relates to fluid flow systems, and more particularly to a check valve assembly that regulates fluid flow rate and enhances stoppage and re-starting of fluid flow in piping systems.

BACKGROUND ART

Piping systems exist to facilitate the flow of fluids (e.g., liquid, gas (such as air) or plasma). For example, homes, schools, medical facilities, commercial buildings and other occupied structures generally require integrated piping systems so that water and/or other fluids can be circulated for a variety of uses. Liquids and/or gases such as cold and hot water, breathable air, glycol, compressed air, inert gases, natural gases, cleaning chemicals, waste water, plant cooling water and paint and coatings are just some examples of the types of fluids and gases that can be deployed through piping systems. Tubing/piping types can include, for example, copper, stainless steel, CPVC (chlorinated polyvinyl chloride) and PEX (cross-linked polyethylene). For purposes of the present disclosure, the term “pipe” or “piping” will be understood to encompass one or more pipes, tubes, piping elements and/or tubing elements.

Piping connections are necessary to join various pieces of pipe and must be versatile in order to adapt to changes of pipe direction, fluid types and fluid flow rates required in particular piping system implementations. For example, fittings and valves may be employed at the ends of open pieces of pipe that enable two pieces of pipe to fit together in a particular configuration. Among fitting types there are elbows, “tees”, couplings adapted for various purposes such as pipe size changes, ends, ball valves, stop valves, check valves and partial angle connectors, for example.

Valves have different purposes depending upon the application. Washing machines, heaters, sinks, ice makers and other home and commercial appliances typically operate with fluid flow valves in order to regulate fluid flow operations and prevent damage. For example, if a washing machine hose bursts, it can discharge hundreds of gallons of water in an hour or less, and cause catastrophic damage as a result. A flow check valve or stop valve can be provided on the washing machine and can include a sensor to sense the water flow and automatically shut the water off if a hose bursts, for example.

Check valves are provided with two ports – one that allows fluid to enter and one that allows fluid to leave. Check valves operate to allow fluid to flow in one direction only through the valve. Flow check valves operate to monitor and maintain the flow rate of fluid

through the valve, regardless of the inbound pressure. In any piping system, maintaining the balance of fluid flow to fluid pressure is paramount. The present invention provides a flow check valve that maintains the balance of fluid flow to fluid pressure in a manner that avoids leaks, flooding and other valve problems in the event of downstream system failure.

5

SUMMARY OF INVENTION

The present invention provides, in part, a valve assembly and method that maintains balance of flow to pressure in fluid and gas piping system applications. In one embodiment, the present invention includes a main body component adapted to retain a chamber body component, a fluid control plate and seal, and a chamber cap. The chamber body component is slidably maintained within the main body component. A resilient gland member is securably attachable to one end of the main body component and the chamber body component, and acts as a seal and a memory for returning the chamber body component to a standard operating position upon fluid pressure environment shifting the chamber body component towards a shut off position. The chamber cap, gland member and a piston seal support member (also called a pressure plate member) act as an end body member securable to an end of the main body component and chamber body component. The chamber body component can include a head portion with a sealing ring maintained therein, with the sealing ring slidably engaging the inner surface of the main body component during operation.

As a flow check valve, the present invention is not necessarily concerned with preventing water or fluid from flowing back into the system. In one embodiment, the flow check plate (also known as a restrictor plate) of the present invention is secured to the flood stop control seal, which acts as a valve. The valve is biased in the open position and is set to allow certain flow (e.g., 2.5 gallons per minute) via the restrictor plate. The valve and plate are unaffected by the fluid pressure, but react to variations in the fluid flow. The remainder of the device acts as a regulator in order to maintain the balance of flow to pressure. For example, if pressure goes from 35 psi (pounds per square inch) to 80 psi within the device, the chamber body component (a.k.a., the piston) will be pushed towards the flood stop control seal and the gland member will be stretched. The chamber body front end will eventually engage the flood stop control seal, at which time the overflow ports of the chamber body member will be inside an interior chamber of the device exposed to a positive displacement area formed between the main body component and the chamber body component. Further, the fluid diverted through the overflow ports will stay in this interior chamber and act to retain the piston in the engaged position preventing water flow through or

past the valve. When the pressure subsides, the gland member is then strong enough and has sufficient retention connections with the main body component and chamber body component to retract and bring the piston back, allowing fluid flow past the valve and releasing the check. The overflow ports are then re-positioned back in the second portion of the main body chamber exposed to an area between the main body component's rampart member and the chamber cap.

In one embodiment of the present invention, the valve assembly of the present invention can be inserted into existing piping or tubing systems as a retrofit device.

10 BRIEF DESCRIPTION OF THE DRAWINGS

Fig. 1 is an exploded front perspective view of one embodiment of the valve assembly of the present invention.

Fig. 2 is an exploded front perspective view of one embodiment of the valve assembly of the present invention, with components shown in cross-section.

15 Fig. 3 is a front cross-sectional view of the chamber body component in accordance with one embodiment of the present invention.

Fig. 4 is a top plan view of a cap member in accordance with one embodiment of the present invention.

20 Fig. 5 is a cross-sectional view of the embodiment of the cap member taken along line 5-5 of Fig. 4.

Fig. 6 is a front view in cross-section of one embodiment of the main body member of the present invention.

Fig. 7 is a breakout view of encircled portion 7-7 of Fig. 6.

25 Fig. 8 is a top plan view of a gland member in accordance with one embodiment of the present invention.

Fig. 9 is a cross-sectional view of the embodiment of the gland member taken along line 9-9 of Fig. 4.

Fig. 10 is a breakout view of encircled portion 10-10 of Fig. 9.

30 Fig. 11 is a front perspective view of the cross-section of the valve assembly in accordance with one embodiment of the present invention.

Fig. 12 is an exploded front perspective view of an alternative embodiment of the valve assembly of the present invention.

Fig. 13 is an exploded front perspective view of the embodiment of the valve assembly of Fig. 12, with components shown in cross-section.

Fig. 14 is a front cross-sectional view of the chamber body component in accordance with one embodiment of the present invention.

Fig. 15 is a front view of one embodiment of the flow restrictor in accordance with the present invention.

5 Fig. 16 is a cross-sectional view of the flow restrictor of Fig. 15 taken along line 16-16.

Fig. 17A is a front view of a pressure plate in accordance with one embodiment of the present invention.

10 Fig. 17B is a cross-sectional view of the pressure plate of Fig. 17A taken along line 17B-17B.

Fig. 18A is a front view of a fluid control plate in accordance with one embodiment of the present invention.

Fig. 18B is a rear view of the fluid control plate of Fig. 18A.

15 Fig. 18C is a left side cross-sectional view of the fluid control plate of Figs. 18A and 18B, taken along the line 18C-18C of Fig. 18B.

Fig. 19A is a top plan view of a cap member in accordance with one embodiment of the present invention.

Fig. 19B is a cross-sectional view of the embodiment of the cap member taken along line 19A-19A of Fig. 19A.

20 Fig. 20A is a front view of one embodiment of the gland member of the present invention.

Fig. 20B is a cross-sectional view of the embodiment of the gland member taken along line 20B-20B of Fig. 20A.

Fig. 20C is a breakout view of encircled portion **V** of Fig. 20B.

25 Fig. 20D is a breakout view of encircled portion **W** of Fig. 20B.

Fig. 21 is a front perspective view of the cross-section of a valve assembly in accordance with another embodiment of the present invention.

DESCRIPTION OF EMBODIMENTS

30 As shown in Figs. 1-11, the valve assembly 10 of the present invention includes a main body component 15 and a chamber body component 20. It will be appreciated that the assembly of the present invention is provided so as to be inserted, affixed and/or installed within a piping or tubing component (not shown).

The main body component 15 and chamber body component 20 are substantially cylindrical bodies with fluid passageways extending axially therethrough, and these components are axially aligned when engaged in accordance with the present invention. In one embodiment of the present invention, main body component 15 and chamber body component 20 are made of brass. In another embodiment of the present invention, one or both of these components may consist of copper or nylon, or other suitable material for the purposes undertaken in accordance with the present invention.

As shown in Figs. 2, 6 and 7, the main body component 15 includes an outer wall 22 and an inner wall 24. Together, the inner wall 24 and outer wall 22 comprise an integrated wall. The outer wall 22 of main body component 15 is capable of securely engaging the inner wall of a piping or tubing component.

The outer wall 22 extends from a cap edge portion 26 at a first axial end 28 of the main body component 15 to a grooved edge portion 30 at a second axial end 32 of the main body component 15. The cap edge 26 is a machined lip extending radially outwardly of the outer wall 22 of the main body component and includes a pipe or tube facing internal face 34, an outer face 36 and an outer edge 38. As shown in Figs. 6-7, the grooved edge portion 30 is formed so as to provide a radially outwardly extending retaining edge 40 having a pipe or tube facing external face 42, an outer edge 44 and an inner face 46. The grooved edge portion 30 further includes an outer wall 48 and a body portion side wall 50, such that the body portion side wall 50, the outer wall 48 and the inner face 46 of the retaining edge 40 form an annular groove 52 extending circumferentially around the main body component 15. The annular groove 52 receives an exterior lip of a gland member as described hereafter.

The inner wall 24 of the main body component 15 includes a radially inwardly extending rampart member 55 having a first side wall 56, a second side wall 58 and an interior edge 60. The rampart member 55 assists in providing a channel 51 and a physical resistance structure employed by the chamber body 20 and further assists in establishing a positive displacement area during operation of the present invention as will be described hereinafter. In one embodiment of the present invention, as shown in Fig. 11, the rampart member second side wall 58 cooperates with the chamber body member 20 to form a positive displacement cavity 59.

The interior edge 60 is capable of slidingly engaging the chamber body component 20 during operation of the present invention, as described in more detail hereafter. In one embodiment of the present invention, the inner wall 24 includes a tapered surface element 62 at the first axial end 28 of the main body component 15. As shown in Fig. 2, the tapered

surface element 62 begins at a taper point 64 extending circumferentially around the inner wall 24 and ends at a position 66 under an interior lip 65 of the cap edge 26. In this way, the tapered surface element 62 and the cap edge interior lip 65 can engage a fluid control plate as described in more detail hereafter.

5 As shown in Figs. 2 and 3, the chamber body component 20 includes an outer wall 70 and an inner wall 72, together comprising an integrated wall, with the outer wall 70 capable of slidingly engaging the interior edge 60 of the rampart member 55 of main body component 15. In this way, the chamber body component 20 is not permitted to veer off its axial course during operation, and space is provided appropriately between the outer wall 70 of the
10 chamber body component 20 on both sides of the rampart member 55 of the main body component to permit fluid flow, as shown in Figs. 11 and 21. The chamber body component 20 can take the form of a substantially cylindrical body element having a channel or cavity 21 therethrough to permit axial flow of fluids.

The chamber body component 20 is also formed to include one or more propulsion
15 ports 75 in order to permit fluid to flow in and out of the cavity of the chamber body component during operation. In one embodiment of the present invention, the propulsion ports 75 are positioned so as to function only upon saturation of the flow area, as will be described in more detail hereafter. The outer wall 70 of the chamber body component 20 extends from a first axial end 76 to a second axial end 78. The chamber body component 20
20 is formed to include a chamber body head member 80 extending radially outwardly from the outer wall 70 proximate the first axial end 76 and a gland engaging end 82 extending radially outwardly from the outer wall 70 proximate the second axial end 78. As shown in the embodiment of Fig. 3, the head member 80 extends substantially perpendicularly from the outer wall 70 while the gland engaging end 82 extends as indicated at 83 at an acute angle
25 from the outer wall. It will be appreciated that, while the present invention contemplates other embodiments wherein such extension angles differ from that shown in Fig. 3, the angles shown in Fig. 3 assist in structurally supporting the chamber body component 20 within the overall device of one embodiment of the present invention during operation.

In the embodiment of the present invention as shown in Figs. 14 and 21, the gland
30 engaging end 382 of the chamber body component 320 does not extend radially in either direction from the outer wall 470. Further, the chamber body component 320 is tapered at the gland engaging end 382, which permits the gland member 330 and the cap 315 to securably engage the chamber body component 320 while maintaining the substantially consistent diameter **D** of radial passageway 321 through the chamber body component 320 when cap

315 is inserted, as shown in Fig. 21. Further, as shown in Figs. 14 and 21, the head member 480 of the chamber body component 320 can be provided with radially extending internal 302 and external 304 lobes defining a sealing ring gap 305 therebetween. The sealing ring gap 305 is adapted to receive a sealing ring 308 that is at least partially if not substantially or
5 entirely maintained in the gap 305 when engaging the inner wall 24 of the main body component 15 during operation of this embodiment of the present invention. The internal lobe 302 has an outer wall surface 309 and the external lobe 304 has an outer wall surface 307 that are slidably engageable with the main body component inner wall 24 during operation.

10 As shown in the embodiment illustrated in Fig. 3, the gland engaging end 82 of the chamber body component 20 includes an external body wall 84, an outer radial wall 86 and an outer axial wall 88. The outer radial wall 86 includes an inner face 91 and an outer face 92, and the outer axial wall 88 includes an inner face 93, an outer face 94 and a radial internal edge 95. An annular groove 100 is formed by the outer radial wall inner face 91, the outer
15 axial wall inner face 93 and the first external body wall 84 of the chamber body component 20. The annular groove 100 receives an interior lip of a gland member as described hereafter.

As shown in the embodiment of the chamber body component 320 illustrated in Fig. 14, the gland engaging end 382 includes an outer radial wall 386, an inner radial wall 387 and an outer axial wall 388. The inner radial wall 387 and the outer axial wall 388 cooperatively
20 engage the interior lip of a gland member as described hereafter.

In one embodiment of the present invention, as shown in Fig. 6, the radius R1 of the first portion 61 of the main body component chamber that houses the chamber body head member 80 is greater than the radius R2 of the second portion 63 of the main body component chamber. This arrangement assists in creating the desired fluid pressure
25 differential between that occurring near the fluid outbound area (i.e., the area around where plate 170 is located) and that occurring near the fluid inbound area (i.e., from the area where gland 130 is located). Additionally, in one embodiment of the present invention, as shown in Figs. 3 and 6, the chamber body head member 80 has a radius R4 that is slightly less than the radius R1 of the first portion 61 of the main body component chamber, and the chamber body
30 component 20 radius R5 (to outer wall 70, shown in Fig. 3) is slightly less than the internal radius R3 of the rampart member 55 within main body component 15. In one embodiment, the relationship of the respective radii can be such that the chamber body head member radius R4 is from 0.002 to 0.015 inches less than the radius R1 of the first portion 61 of the main body component chamber, inclusive, and chamber body component radius R5 is similarly

from 0.002 to 0.015 inches less than the radius R3 of the rampart member 55. At the 0.002 inch difference, the maximum amount of tolerable friction occurs. If the distance exceeds the 0.015 inch difference, the chamber body head member 80 and component 20 may not slide evenly within the main body component chamber 61 and within the area encircled by the rampart member 55, respectively. As such, there may not be enough balancing pressure or back pressure to support proper operation of the components of the present invention.

As shown in Figs. 2 and 3, the annular groove 52 within the main body component 15 faces radially outwardly while the annular groove 100 within the chamber body component 20 faces radially inwardly. This arrangement permits the present device to securely engage the gland member described below while maintaining substantially coaxial and parallel alignment of the main body component and chamber body component. Such an arrangement and positioning assists the present device during operation such that fluids and gases do not escape or infiltrate the present invention components as an unintended consequence. In the embodiment of the present invention shown in Figs. 14 and 21, there is no annular groove within the chamber body component 320. However, the chamber body component 320 is similarly securely engageable with the end body arrangement 350 in this embodiment. The end body arrangement 350 can comprise, for example, the gland member 330. The end body arrangement can also comprise the gland member 330, a pressure plate member 355 and chamber cap 315. Figs. 12 and 13 illustrate various components employed in alternative embodiments of the present invention to those shown in Figs. 1 and 2, including main body component 15, chamber body component 320, end body arrangement 350, with gland member 330, pressure plate member 355 and chamber cap 315. Figs. 12 and 13 also show fluid control plate 370, flow restrictor 380 and sealing ring member 308. Once assembled, the chamber body component 320 modulates during operation to restrict fluid flow based upon the inbound fluid pressure. The restricted flow volume flows over the flow restrictor 380. In the event the downstream flow is greater than the restricted volume, the chamber body component 320 shuttles forward to stop the fluid flow.

As shown in Figs. 1-5, the inner wall 72 of the chamber body component 20 is provided with a thread 110 proximate the second axial end 78 for receiving an end cap 115 as described hereafter. The inner wall 72 further extends through the chamber body head member 80, extending radially inwardly to form an interior ring 120 having a first side wall 122, a second side wall 124 and a radially inward edge 126. A bevel wall 128 extends from the inner wall 72 at a position adjacent the first side wall 122 of the interior ring 120, and the bevel wall 128 is angled so as to cooperatively engage a control seal during operation of the

present invention, as described hereafter. In the embodiment of the present invention as shown in Figs. 14, 19A, 19B and 21, for example, the inner wall 472 of chamber body component 320 is similarly provided with a thread 310 proximate the gland engaging end 382 for receiving an end cap 315. Further, the inner wall 472 of the embodiment of Fig. 14 has a comparable interior ring 320 having a first side wall 322, a second side wall 324 and a radially inward edge 326. A bevel wall 328 extends from the inner wall at a position adjacent the first side wall 322 of the interior ring 320, and the bevel wall 328 is angled so as to cooperatively engage a control seal 389 of restrictor 380 (see Fig. 16) during operation of the present invention.

One embodiment of the gland member 130 of the present invention is shown in Figs. 1-2 and 8-10. As shown therein, the gland member 130 comprises a unitary, substantially rigid yet somewhat flexible element that acts as both a sealing member and a spring or pressure-balancing member for the device of the present invention. In embodiments of the present invention, the gland member 130 is a ring-shaped device having a solid body forming a central opening therethrough such that the gland member is effectively hollow. The gland member has a radially outer wall 132, a radially inner wall 134 and an exterior wall 136. The gland member 130 further is formed with an interior face 138 having a substantially C-shaped cross-section with exterior 140 and interior 142 lip elements. As shown in Fig. 10, the exterior lip 140 includes a front wall 150, a radially inward wall 152 and an interior wall 154, and the interior lip 142 includes a front wall 160, a radially inward wall 162 and an interior wall 164. Further, each of the gland member exterior wall 136, radially outer wall 132 and radially inner wall 134 includes a respective inner surface 144, 145, 146, whereby the respective inner surfaces 144, 145, 146 and the lip members 140, 142 cooperatively engage the annular grooves 52, 100 of the main body component 15 and the chamber body component 20, respectively.

In one embodiment of the present invention, as shown in Fig. 10, the front wall 150 of the exterior lip 140 extends further outwardly than the front wall 160 of the interior lip 142, and the interior wall 154 of the exterior lip 140 extends further inwardly than the interior wall 165 of the interior lip 142. Such an arrangement provides the exterior lip 140 with greater surface area and thereby greater strength of connection with main body component than the interior lip 142 enjoys with the chamber body component 20. Further, as shown in the embodiment of the present invention shown in Fig. 10, the radially outer wall 132 of the gland member is thicker in width and shorter in length than the radially inner wall 134. As a result, the interior lip 142 has a modest amount of additional flexibility to thereby operate as

intended, by permitting the chamber body component 20 to move axially within the main body component chamber. In one embodiment of the present invention, as shown in Fig. 9, the length L_1 of the radially inner wall 132 can range from approximately 125% to approximately 167% the length L_2 of the radially outer wall 134, and the width W_1 of the radially inner wall 132 can range from approximately 20% to approximately 40% the width W_2 of the radially outer wall 134. In a further embodiment of the present invention, the width W_3 of the exterior lip radially inward wall 152 is approximately 175% to approximately 300% the width W_4 of the interior lip radially inward wall 162.

In embodiments of the present invention as shown in Figs. 20A through 20D and 21, the gland member 330 includes a similar radially outward portion 430 to the embodiment shown in Figs. 8-10, including an exterior lip 340. In this embodiment, the gland member 330 includes a radially outer wall 332, a radially inner wall 334, an exterior wall 336 and an interior face 338. The interior face 338 of the gland member 330 engages the gland engaging end 82 of the embodiment of the chamber body component 320 shown in Fig. 21. Together with the pressure plate member 355 and chamber cap 315, the gland member 330 is securely engageable with the chamber body component 320. In embodiments of the present invention, the gland member 330 can comprise the same material as gland member 130. In embodiments of the present invention, the exterior wall 336 of the gland member 330 shown in Fig. 20B is provided with a thickness T of from 0.0001 inches to 0.25 inches, inclusive. The thickness T of gland member 330 determines the travel of chamber body component 320 during operation, as the thicker the thickness T , the less the chamber body component 320 will travel axially. As shown in Fig. 21, the exterior lip 340 of the gland member cooperatively engages the annular groove 52 of the main body component when secured in position. As further shown in Figs. 20A through 20D, the radially inner wall 334 of gland member 330 has a flange portion 432 extending axially inwardly, which can securely engage radially inner wall 472 (see Fig. 14) of chamber body member 320. In one embodiment of the present invention, the flange portion 432 is substantially perpendicular to the exterior wall 336, and can be provided with a beveled edge 434 for securely engaging a body ridge element 415 in the outer wall 416 of chamber cap 315. In embodiments of the present invention the flange portion 432 extends a distance F from the face 338 of the exterior wall 336, as shown in Fig. 20D, while the lip 340 extends a distance L from the face of the exterior wall, as shown in Fig. 20C. Distance L can be provided as longer than distance F in embodiments of the present invention, in order to provide increased strength of securement on the radially outer portion of the end body arrangement 350, and in order to accommodate

the additional internal elements, such as the chamber cap 315 and chamber body component 320.

In the embodiment of the invention as shown in Figs. 19A through 21, the chamber cap 315 has a neck portion 417 of sufficient axial width to accommodate snug and cooperative engagement of the radially inner wall 334 of the gland member 330 when engaged. Further, the lip 340 can be provided as shown in Fig. 20C with a substantially rounded radially inner surface 341 (similar to sealing ring 308). The interior walls 338, 339 of gland member 330 engage the retaining edge 40 of the main body component when secured.

As shown in Figs. 2, 4 and 5, a chamber cap 115 is provided in the form of a substantially cylindrical-shaped body 205 having a cavity 208 extending axially therethrough with a head portion 210 at one end 212 of the body 205. The head portion 210 can be of any shape that can be manipulated for clockwise and counter-clockwise rotation, and is shown in Fig. 4 in a hexagonal shape. The body portion 205 is provided with an external thread 214 for mating with the internal thread 110 of the chamber body component 20.

As shown in Figs. 19A and 19B, a similar chamber cap 315 is shown with similar features to cap 115. However, cap 315 includes a head portion 313, a body portion 311 having a cavity 312 extending axially therethrough. The cap further has a neck portion 417, with the body portion 311 having an outer surface that includes a thread 418 for mating with thread portion 310 of chamber body component 320. The cap neck portion 417 and ridge 415 provide a gland-engaging segment. A plate engaging segment 419 extends from the neck portion 417 adjacent the head portion 313 and engages plate member 355 when cap 315 is securely retained within chamber member 320. When securing the cap 315 with chamber body member 320 via threaded engagement, the plate member 355 is placed around the neck portion of the chamber cap 315 (similar to a washer around a bolt or screw), and the plate member 355 then engages the outer wall 336 of the gland member 330, the inner side wall 516 of the cap head portion 313 and the plate engaging segment 419 of the cap neck portion 417. The arrangement of the gland member 330, pressure plate member 355 and cap member 315 provide a secure seal at the ends of the main body member 15 and chamber body member 320 during operation. As shown in Figs. 17A and 17B, the pressure plate member 355 is a ring-shaped device having a solid body forming a central opening 356 therethrough. The pressure plate member is provided with a first side portion 357, a second side portion 358, a radially outer edge 359 and a radially inner edge 353. When secured between the chamber cap 315 and gland member 330, the first side portion 357 is cooperatively engaged

with the gland member wall 336, the second side portion 358 is cooperatively engaged with the cap head inner wall 516 and the inner edge 353 is cooperatively engaged with the plate engaging segment 419 of the cap neck portion.

In one embodiment of the present invention as shown in Figs. 1, 2, 11 and 12, a fluid control plate 170 is designed with one or more fluid control plate flow ports 172 to allow fluid to flow therethrough. The fluid control plate 170 can receive a flow restrictor 180 extending through a central axial opening 173 of the plate, and the flow restrictor 180 thereby extends axially inwardly and into the first portion 61 of the cavity of the main body component 15. In one embodiment of the present invention, the flow restrictor 180 includes a flood stop control seal or plunger seal 182 that assists in sealing the fluid flow during operation of the device, when required. As shown in Figs. 1, 2 and 11, the control seal 182 can have a wider flow-facing end 186 tapered to a narrower downstream end 184. The outer edge 188 of the flow-facing end 186 of the control seal 180 is adapted to mate with the bevel wall 128 of the chamber body component 20 in substantially flush relation during operation if and when the valve is positioned in shut-off position. The flow restrictor 180 includes a neck portion 189 that securely fits within central axial opening 173 of the plate, as shown in Figs. 1 and 11. The edge 175 of the fluid control plate 170 can be considered a stabilizer edge and wall 174 can be considered a snap slope edge in that the fluid control plate can snap into position within the main body component 15 as a result of the tapered surface element 62 in the main body member inner wall 24, as shown in Fig. 11. In one embodiment of the present invention, the fluid control plate 170 and the flow restrictor 180 with flood stop control seal 182 are separate components, with the flow restrictor 180 being insertable and retainable within fluid control plate 170 by pushing downstream end 184 through the central axial opening 173 of the fluid control plate 170. An upstream central plug element 187 of the flow restrictor 180 is also provided and can assist with restricting fluid flow during operation as the chamber body component 20 is pushed towards the flow restrictor 180, as the ring extension 124 surpasses and encircles the plug element 187 if fluid flow exceeds allowed rates, as described in connection with the operation of the invention elsewhere herein. In one embodiment of the present invention, the fluid control plate 170 can be formed of a polymeric material such as polyoxymethylene (POM) and the flow restrictor 180 with flood stop control seal 182 can be formed of EPDM rubber (ethylene propylene diene monomer (M-class) rubber) material. Similarly, the gland members 130, 330 described herein can be formed of EPDM rubber, for example, or similar elastomeric material, in accordance with one embodiment of the present invention.

In the embodiment of the present invention as shown in Figs. 18A through 18C and 21, the fluid control plate 370 is substantially similar to plate 170 in Fig. 11, including flow ports 472 and central axial opening 475. The edge 477 of the fluid control plate 370 can be considered a stabilizer edge and wall 474 can be considered a snap slope edge in that the fluid control plate 370 can snap into position within the main body component 15 as a result of the tapered surface element 62 in the main body member inner wall 24. In one embodiment of the present invention, as shown in Fig. 18C, the edge 477 extends at an angle **E** of between approximately one degree and 30 degrees, inclusive.

As shown in Figs. 15 and 16, flow restrictor 380 can be modified from restrictor 180 such that it is larger and therefore contains additional surface area for engaging plate 370 and the head portion 480 of the chamber body member 320. In this way, restrictor 380 can better resist being forced through the central opening in the plate 370 during operation, which may otherwise occur with high fluid flow rates and/or pressures. The flow restrictor 380 shown in Figs. 15 and 16 includes a neck portion 385 for secure engagement and retention within central axial opening 475 of plate 370. The flow restrictor 380 also includes a flood stop control seal or plunger seal 382 that assists in sealing the fluid flow during operation of the device, when required. As shown in Fig. 16, the control seal 382 can have a wider flow-facing end 388 tapered to a narrower downstream end 384. The outer edge 389 of the flow-facing end 388 of the control seal 382 is adapted to mate with the bevel wall 328 of the chamber body component 320 in substantially flush relation during operation if and when the valve is positioned in shut-off position. In one embodiment of the present invention, additional supporting material for the flow-facing end 388 can be provided such as illustrated in dashed lines at 395 in order to give the control seal further strength and surface area. In one embodiment of the present invention, the fluid control plate 370 and the flow restrictor 380 with flood stop control seal 382 are separate components, with the flow restrictor 380 being insertable and retainable within fluid control plate 370 by pushing downstream end 384 through the central axial opening 475 of the fluid control plate 370. An upstream central plug element 387 of the flow restrictor 380 is also provided and can assist with restricting fluid flow during operation as the chamber body component 320 is pushed towards the flow restrictor 380, as the ring extension 324 surpasses and encircles the plug element 387 if fluid flow exceeds allowed rates, as described in connection with the operation of the invention elsewhere herein. In one embodiment of the present invention, the fluid control plate 370 can be formed of a polymeric material such as polyoxymethylene (POM) and the flow restrictor

380 with flood stop control seal 382 can be formed of EPDM rubber (ethylene propylene diene monomer (M-class) rubber) material.

With regard to a method of assembly of the valve device of the present invention shown in Fig. 11, the chamber body component 20 is inserted through an opening 190 at the first axial end 28 of the main body component 15, and the fluid control plate 170 with flow restrictor 180 and flood stop control seal 182 is inserted and secured into the cap portion 26 of the main body component 15. The gland member 130 is secured to the main body component 15 and the chamber body component 120 such that the external 140 and internal 142 lips of the gland member 130 securely engage the annular grooves 52, 100 described above. The chamber cap 115 is then inserted through the gland member 130 such that the external thread 214 on the chamber cap 115 securely engages the internal thread 110 on the chamber body component 20.

With regard to a method of assembly of the valve device of the present invention shown in Fig. 21, a sealing ring 308 is inserted into chamber 305 in the chamber body component 320, and the chamber body component 320 is inserted through the main body component 15 in a manner similar to that described above. The plate 370 and flow restrictor 380 are also inserted and secured into the main body component 15 as described above. The gland member 330 is secured to the main body component 15 and the chamber body component 320 such that the external 340 lip and interior face 338 of the gland member 330 securely engage the chamber body component 320. The pressure plate member 355 is then placed around the body of the chamber cap 315 so as to securely engage the plate engaging segment 419 of the chamber cap 315. In one embodiment of the present invention, the pressure plate outer diameter **P** (see Fig. 17A) is at least 101% of the outer diameter **Z** (see Fig. 14) of chamber body component 320. The chamber cap 315 is then inserted through the gland member 330 such that the external thread 311 on the chamber cap 315 securely engages the internal thread 310 on the chamber body component 320 and such that the plate member 355 is securely retained between the gland member 330 and the cap head portion 313.

In operation, fluid such as water enters from a piping or tubing element (not shown) into the valve assembly 10 of the present invention from the first axial end of the main body component 15. It will be appreciated that the fluid can be liquid or gas, and will further be appreciated that the specific gravity of the fluid is inconsequential to the operation of the present invention. The fluid enters at a fluid rate measured, for example, in gallons per minute. If the fluid flow maintains the desired rate (e.g., 2.4 gallons per minute), the valve

assembly 10 is unaffected and permits free flow through the cavity of the chamber body component 20 (or 320) and past the flow stop control seal 182 and through the ports 172 in the fluid control plate 170 (or, in the embodiment of Fig. 21, similar elements of restrictor 380 and plate 370). If the incoming fluid flow increases, fluid pressure will build up outside of the chamber body component 20 (or 320) and will extend around the end of the chamber body component (for example, in the areas 250 around the head portion 205 of the chamber cap 115, or alternatively the head portion 313 of cap 315) to push the chamber cap 115 (or 315) towards the fluid control plate end of the assembly. In this process, the chamber body component 20 (or 320) will come closer to the fluid sealing member 182 (or 382), and the gland member 130 (or 330) will stretch to permit the extension of the chamber body component. Additionally, propulsion ports 75 (or 375) will move from a position where they permit fluid to evacuate the chamber body member into channels 255 in Fig. 11 (or 505 in Fig. 21) alongside chamber body component 20 (320 in Fig. 21), to where they permit fluid to evacuate the chamber body member in the positive displacement cavity 59 (or 559 in Fig. 21) and first portion 61 of the chamber of the main body component 15 beyond the rampart member 55 of the main body member 15. The propulsion ports 75 (375 in Fig. 21) thus facilitate some evacuation of fluid from the chamber body member, but ultimately allow the fluid to continue building up and pushing the chamber body member towards the fluid control seal 182 (or 382 in Fig. 21), since the positive displacement cavity 59 (559 in Fig. 21) is relatively small, and the chamber body member will be pushed by fluid within cavity 61 as the fluid pressure builds up against chamber head portion 80 (480 in Fig. 21). It will be appreciated that some balancing fluid flow may occur through slender channels 193, 195 shown in Fig. 11 (or similar channels in the embodiment shown in Fig. 21), assisting with back pressure for the device.

When the fluid flow is so great that the fluid control seal 182 (or 382 in Fig. 21) seals against the seal engaging bevel edge 128 (or 328 in Fig. 14) of the chamber body component 20 (or 320 in Fig. 21), no more fluid can exit through the fluid control plate 170 (370 in Fig. 21). Once the flow rate is reduced externally (e.g., from the incoming area 250 in Fig. 11, or similar areas in Fig. 21), the pressure on the chamber body component is relaxed, and the chamber body component is returned via pressure from the gland member 130 (330 in Fig. 21) away from the fluid control seal 182 (382 in Fig. 21). To the extent similar operations are not described above for the embodiments of the present invention as shown in Figs. 12 through 21, it will be appreciated that such embodiments of the present invention can

facilitate similar operation to that described above in connection with the embodiments of the present invention as depicted in Figs. 1 through 11.

It will be appreciated that the present invention requires no spring, and no sealing ring or O-ring type device in order to facilitate movement of adjacent components in valve
5 devices. Further, the present invention can be provided in a form factor that is significantly smaller than that of other devices. In one embodiment of the present invention, the length of the device when assembled is no greater than 1.25 inches. It will further be appreciated that the present invention is versatile and can be employed with fluids and gases of various types. In one embodiment, the device of the present invention can be employed in environments
10 where fluid flow rates range up to 150 gallons per minute or more, or where air pressure is 250 pounds per square inch or more. As sealing rings can build up frictional pressure and heat over time, they can wear down. Additionally, an oil or silicon impregnated seal can suffer from lower tolerances to high pressure and heat, or may potentially ignite or explode at higher temperatures and/or pressures. As the present invention does not employ such seals, it
15 can bear higher temperatures, flow rates and pressures accordingly. Further, as the present invention does not employ steel or other metal, such as might be present in a spring, for example, the present invention is further able to bear higher temperatures, flow rates and pressures.

20 The scope of the claims should not be limited by the preferred embodiments set forth in the examples, but should be given the broadest interpretation consistent with the Description as a whole.

CLAIMS:

1. A valve assembly, comprising:

a substantially cylindrical-shaped main body component having a first end, a second end and an inner wall defining a cavity extending axially through the main body component, with the inner wall further having a rampart member extending radially inwardly therefrom, wherein the rampart member divides the main body component cavity into a first portion and a second portion;

a substantially cylindrical-shaped chamber body component having a first end, a second end and an inner wall defining a cavity extending axially through the chamber body component, with the chamber body component having an outer wall that is slidably engageable with the rampart member, and wherein the chamber body component further having a head member having a radially extending internal lobe and a radially extending external lobe defining a sealing ring gap therebetween; and

a sealing ring at least partially maintained in the sealing ring gap and engaging the main body component inner wall.

2. The valve assembly of claim 1 wherein the chamber body component head member has an outer wall that is slidably engageable with the rampart member.

3. The valve assembly of claim 1 wherein the head member radially extending internal lobe has an internal lobe outer wall surface and wherein the head member radially extending external lobe has an external lobe outer wall surface, and wherein the internal lobe outer wall surface and the external lobe outer wall surface are slidably engageable with the main body component inner wall.

4. The valve assembly of claim 1, further including a resilient gland member securably engageable to the second end of the main body component and the second end of the chamber body component;

a chamber cap secured to the second end of the chamber body component; and

a fluid control plate securably attachable to the first end of the main body component.

5. The valve assembly of claim 4 further including a pressure plate member secured between the resilient gland member and the chamber cap.

6. The valve assembly of claim 1, wherein the rampart member includes a first side wall, a second side wall and an interior edge, wherein the chamber body outer wall is slidably engageable with the interior edge, and wherein the second side wall and the chamber body outer wall form a positive displacement cavity.

7. The valve assembly of claim 1 wherein the chamber body component includes at least one propulsion port extending radially therethrough.
8. The valve assembly of claim 1 wherein the chamber body component inner wall includes an internally threaded surface proximate the chamber body component second end.
- 5 9. The valve assembly of claim 4 wherein the gland member includes a radially outer wall, a radially inner wall, an exterior wall and an interior face.
10. The valve assembly of claim 9 wherein the gland member radially inner wall includes a flange extending substantially perpendicularly from the interior face.
11. The valve assembly of claim 4 wherein the main body component second end includes an
10 annular groove, and further wherein the gland member includes an exterior lip element cooperatively engages the main body component annular groove.
12. A method for providing a valve assembly, comprising:
- providing a substantially cylindrical-shaped main body component having a first end, a second end and an inner wall defining a cavity extending axially through the main body
15 component, with the inner wall further having a rampart member extending radially inwardly therefrom;
- providing a substantially cylindrical-shaped chamber body component having a first end, a second end, an outer wall and an inner wall, with the inner wall defining a cavity extending axially through the chamber body
20 component further has a head member having a radially extending internal lobe and a radially extending external lobe defining a sealing ring gap therebetween; and
- inserting a sealing ring at least partially in the sealing ring gap; and
- inserting the chamber body component into the main body component such that the chamber body component outer wall is slidably engageable with the rampart member.
- 25 13. The method of claim 12 wherein the sealing ring is engageable with the main body component inner wall.
14. A valve assembly, comprising:
- a substantially cylindrical-shaped main body component having a first end, a second end and an inner wall defining a cavity extending axially through the main body component;
- 30 a substantially cylindrical-shaped chamber body component having a first end, a second end and an inner wall defining a cavity extending axially through the chamber body component, with the chamber body component having an outer wall that is slidably maintained within the main body component cavity; and

an end body arrangement attachable to the second end of the main body component and the inner wall of the chamber body component.

15. The assembly of claim 14 wherein the end body arrangement comprises a resilient gland member, a pressure plate member and a chamber cap.

5 16. The assembly of claim 15 wherein the resilient gland member is securably attachable to the second end of the main body component and the second end of the chamber body component.

17. The assembly of claim 15 wherein the chamber cap includes a head portion and a neck portion, wherein the neck portion has an outer surface having a thread, an axial gland-
10 engaging segment and a pressure plate member engaging segment.

18. The assembly of claim 17 wherein the chamber cap is securably attachable to the chamber body component inner wall, and wherein the pressure plate member and the chamber cap head portion extend axially outwardly of the main body component when the chamber cap is securably attached to the chamber body component inner wall.

15 19. The assembly of claim 15 wherein the resilient gland member has an outer wall, the chamber cap head portion has an inner side wall, and wherein the pressure plate member engages the gland member outer wall, the head portion inner side wall and the cap neck portion pressure plate member engaging segment.

20. A method of providing a valve assembly, comprising:

20 providing a substantially cylindrical-shaped main body component having a first end, a second end and an inner wall defining a cavity extending axially through the main body component;

inserting a substantially cylindrical-shaped chamber body component into the main body component, with the chamber body component having a first end, a second end and an
25 inner wall defining a cavity extending axially through the chamber body component, with the chamber body component having an outer wall that is slidably maintained within the main body component cavity; and

attaching an end body arrangement to the second end of the main body component and the inner wall of the chamber body component.

30 21. The method of claim 20 wherein the end body arrangement comprises a resilient gland member.

22. The method of claim 21 wherein the end body arrangement further comprises a pressure plate member and a chamber cap.

23. A valve assembly, comprising:

a substantially cylindrical-shaped main body component having a first end, a second end and an inner wall defining a cavity extending axially through the main body component, with the inner wall further having a rampart member extending radially inwardly therefrom;

5 a substantially cylindrical-shaped chamber body component having a first end, a second end and an inner wall defining a cavity extending axially through the chamber body component, with the chamber body component having an outer wall that is slidably engageable with the rampart member;

a fluid control plate securably attachable to the first end of the main body component;

10 a resilient, hollow gland member securably attachable to the second end of the main body component and the second end of the chamber body component; and

a hollow chamber cap secured to the second end of the chamber body component.

24. The valve assembly of claim 23, wherein the rampart member includes a first side wall, a second side wall and an interior edge, wherein the chamber body outer wall is slidably engageable with the interior edge, and wherein the second side wall and the chamber body
15 outer wall form a positive displacement cavity.

25. The valve assembly of claim 23 wherein the fluid control plate includes a flood stop control seal extending axially inwardly of the fluid control plate and within the main body component cavity.

26. The valve assembly of claim 23 wherein the rampart member divides the main body
20 component cavity into a first portion and a second portion, and wherein the chamber body component includes a head member capable of axial movement within the first portion of the main body component cavity.

27. The valve assembly of claim 26 wherein the radius of the first portion of the main body
25 component cavity is greater than the radius of the second portion of the main body component cavity.

28. The valve assembly of claim 23 wherein the fluid control plate includes a flood stop control seal extending axially inwardly of the fluid control plate and within the main body component cavity, wherein the chamber body component includes a head member capable of axial movement within the main body component cavity, and wherein the head member
30 includes a bevel edge adapted to engage the flood stop control seal in substantially flush relation.

29. The valve assembly of claim 23 wherein the chamber body component includes at least one propulsion port extending radially therethrough.

30. The valve assembly of claim 23 wherein the chamber body component inner wall includes an internally threaded surface proximate the chamber body component second end.

31. The valve assembly of claim 23 wherein the cap member includes a body portion with an externally threaded surface.

5 32. The valve assembly of claim 23 wherein the chamber body component second end includes an external body wall, an outer radial wall and an outer axial wall, wherein the outer radial wall includes an inner face and an outer face, the outer axial wall includes an inner face, an outer face and a radial internal edge, and wherein the outer radial wall inner face, the outer axial wall inner face and the first external body wall form a chamber body component
10 annular groove.

33. The valve assembly of claim 23 wherein the main body component second end includes a radially outwardly extending retaining edge having an external face, an outer edge and an inner face, and wherein the main body component second end further includes a grooved edge portion having an outer wall and a body portion side wall, such that the grooved edge
15 portion outer wall, body portion side wall and the retaining edge inner face form a main body component annular groove.

34. The valve assembly of claim 23 wherein the gland member includes a radially outer wall, a radially inner wall, an exterior wall and an interior face having a substantially C-shaped cross-section.

20 35. The valve assembly of claim 34 wherein the gland member interior face includes exterior and interior lip elements.

36. The valve assembly of claim 35 wherein the main body component second end includes an annular groove and the chamber body component second end includes an annular groove, and further wherein the exterior lip element of the gland member cooperatively engages the
25 main body component annular groove and the interior lip element of the gland member cooperatively engages the chamber body component annular groove.

37. A method for providing a valve assembly, comprising:

providing a substantially cylindrical-shaped main body component having a first end, a second end and an inner wall defining a cavity extending axially through the main body
30 component, with the inner wall further having a rampart member extending radially inwardly therefrom;

inserting a substantially cylindrical-shaped chamber body component into the main body component, the chamber body component having a first end, a second end and an inner wall defining a cavity extending axially through the chamber body component, with the

chamber body component having an outer wall that is slidably engageable with the rampart member;

securing a fluid control plate to the first end of the main body component;

securing a resilient, hollow gland member to the second end of the main body

5 component and the second end of the chamber body component; and

securing a hollow chamber cap to the second end of the chamber body component.

38. The method of claim 37, wherein the rampart member includes a first side wall, a second side wall and an interior edge, wherein the chamber body outer wall is slidably engageable with the interior edge, and wherein the second side wall and the chamber body outer wall
10 form a positive displacement cavity.

39. The method of claim 37 wherein the rampart member divides the main body component cavity into a first portion and a second portion, and wherein the chamber body component includes a head member capable of axial movement within the first portion of the main body component cavity.

15 40. The method of claim 39 wherein the radius of the first portion of the main body component cavity is greater than the radius of the second portion of the main body component cavity.

41. The method of claim 37 wherein the chamber body component includes at least one propulsion port extending radially therethrough.

20 42. A valve assembly, comprising:

a substantially cylindrical-shaped main body component having a first end, a second end and an inner wall defining a cavity extending axially through the main body component;

a substantially cylindrical-shaped chamber body component having a first end, a second end and an inner wall defining a cavity extending axially through the chamber body component, with the chamber body component having an outer wall that is slidably
25 maintained within the main body component cavity; and

a resilient, hollow gland member securably attachable to the second end of the main body component and the second end of the chamber body component.

30

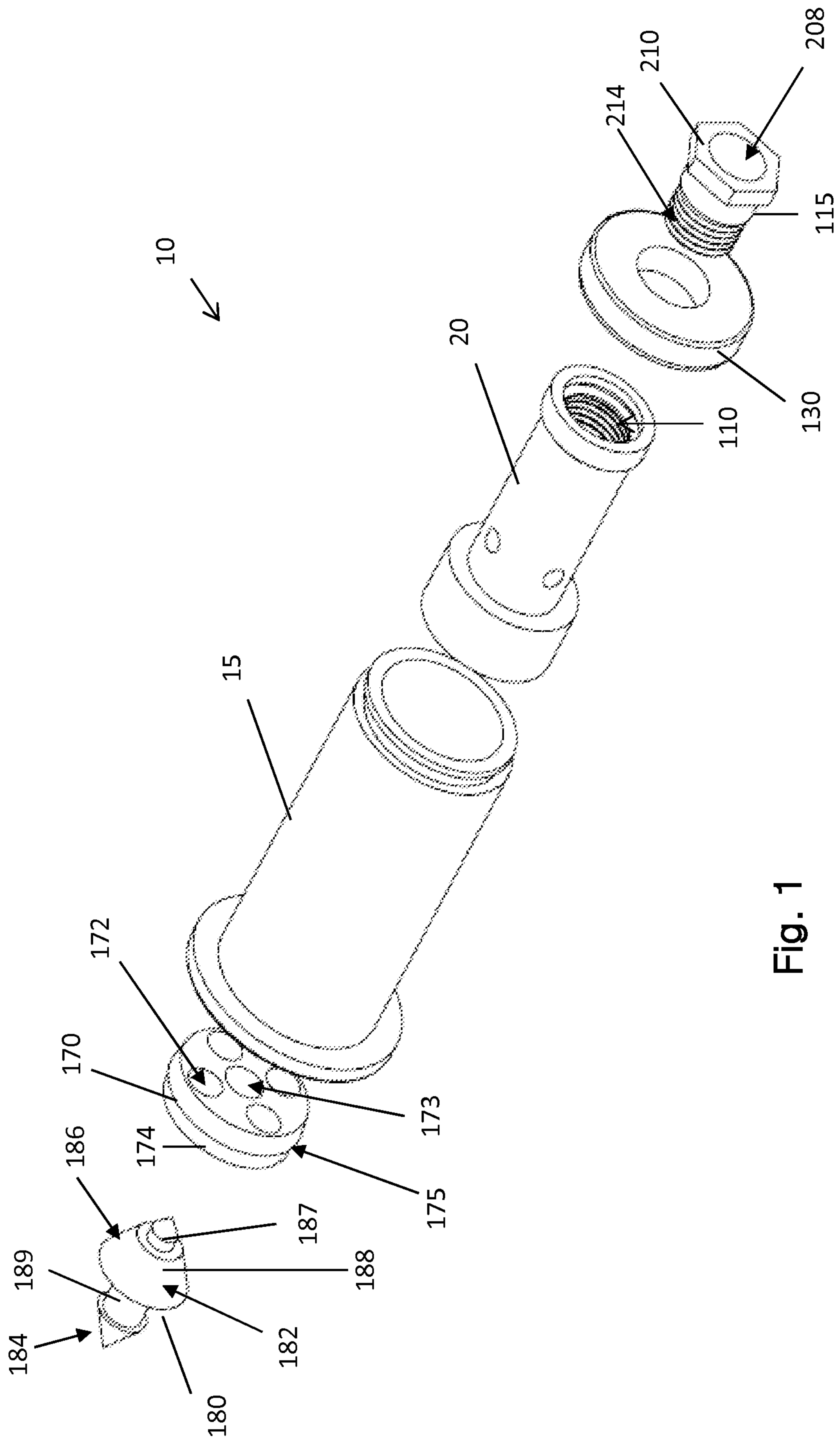

Fig. 1

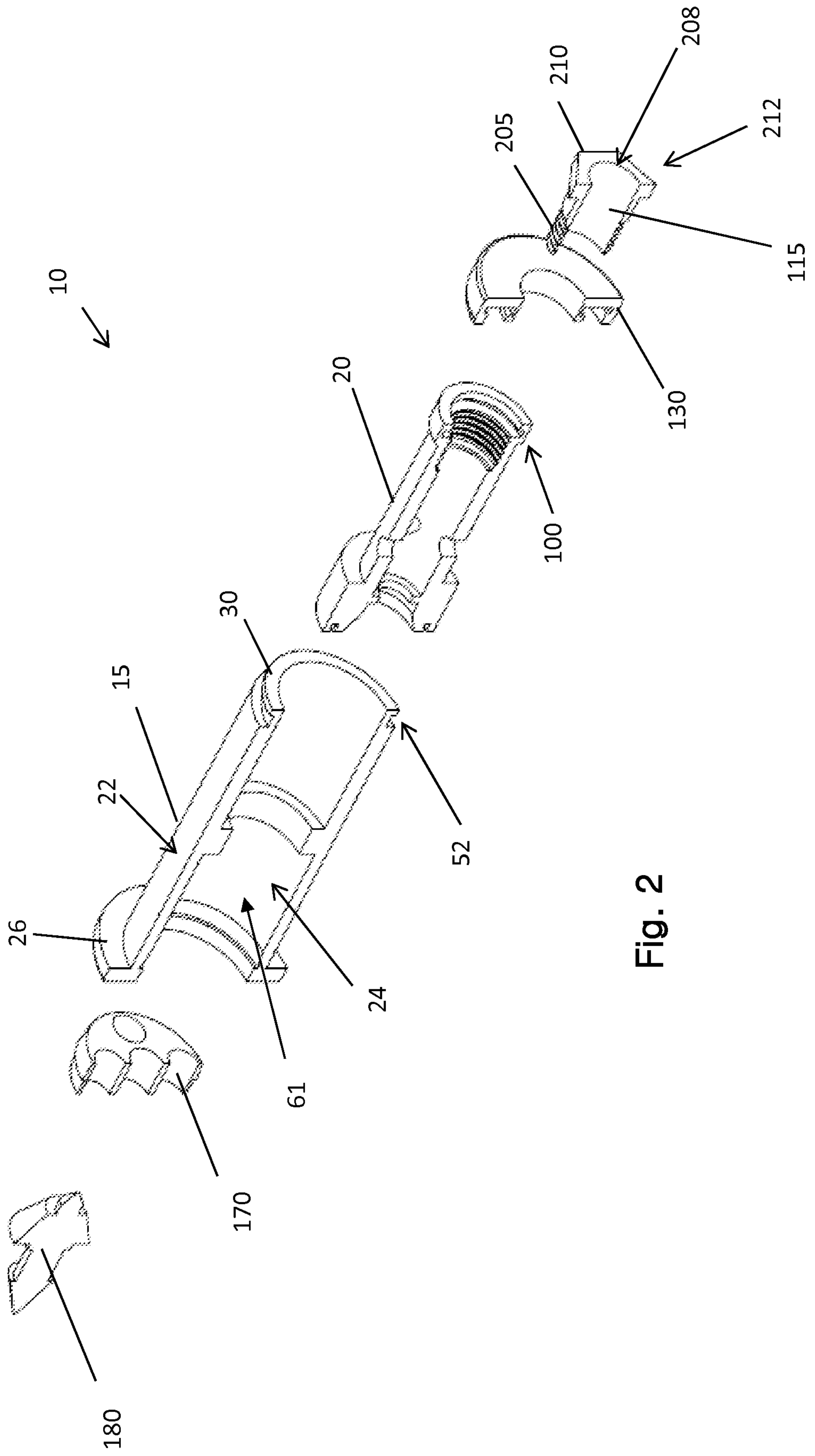

Fig. 2

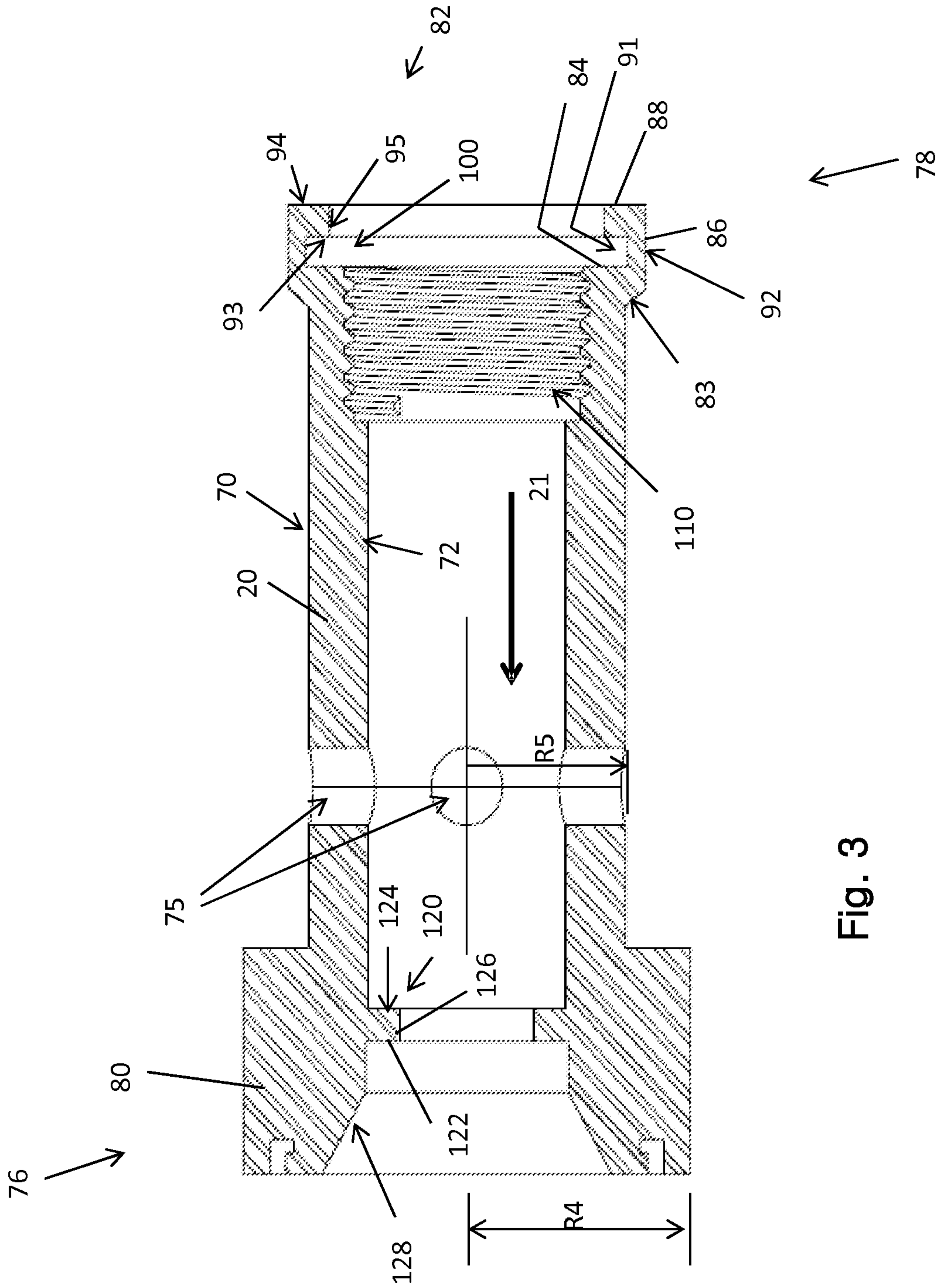

Fig. 3

Fig. 4

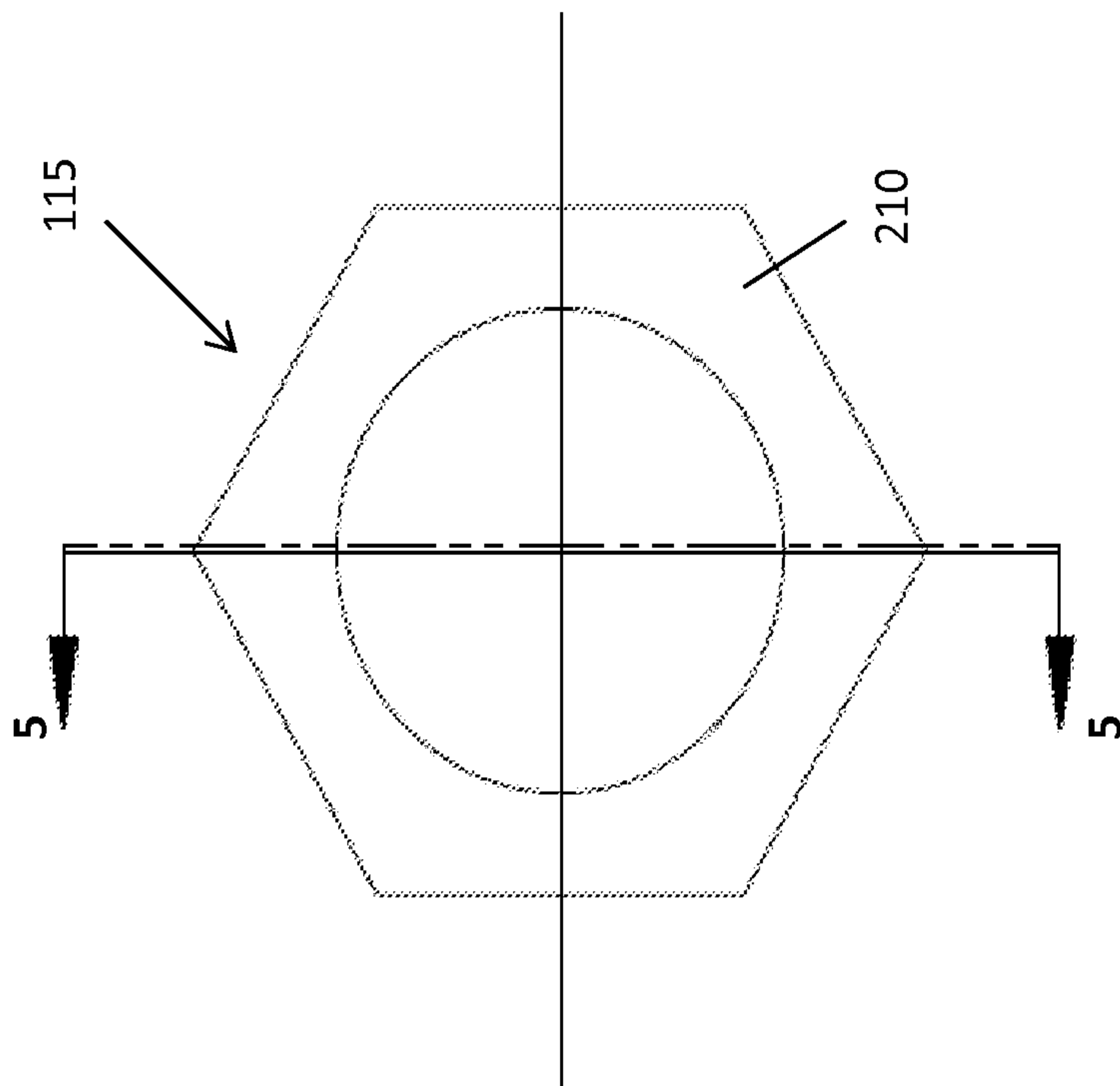

Fig. 5

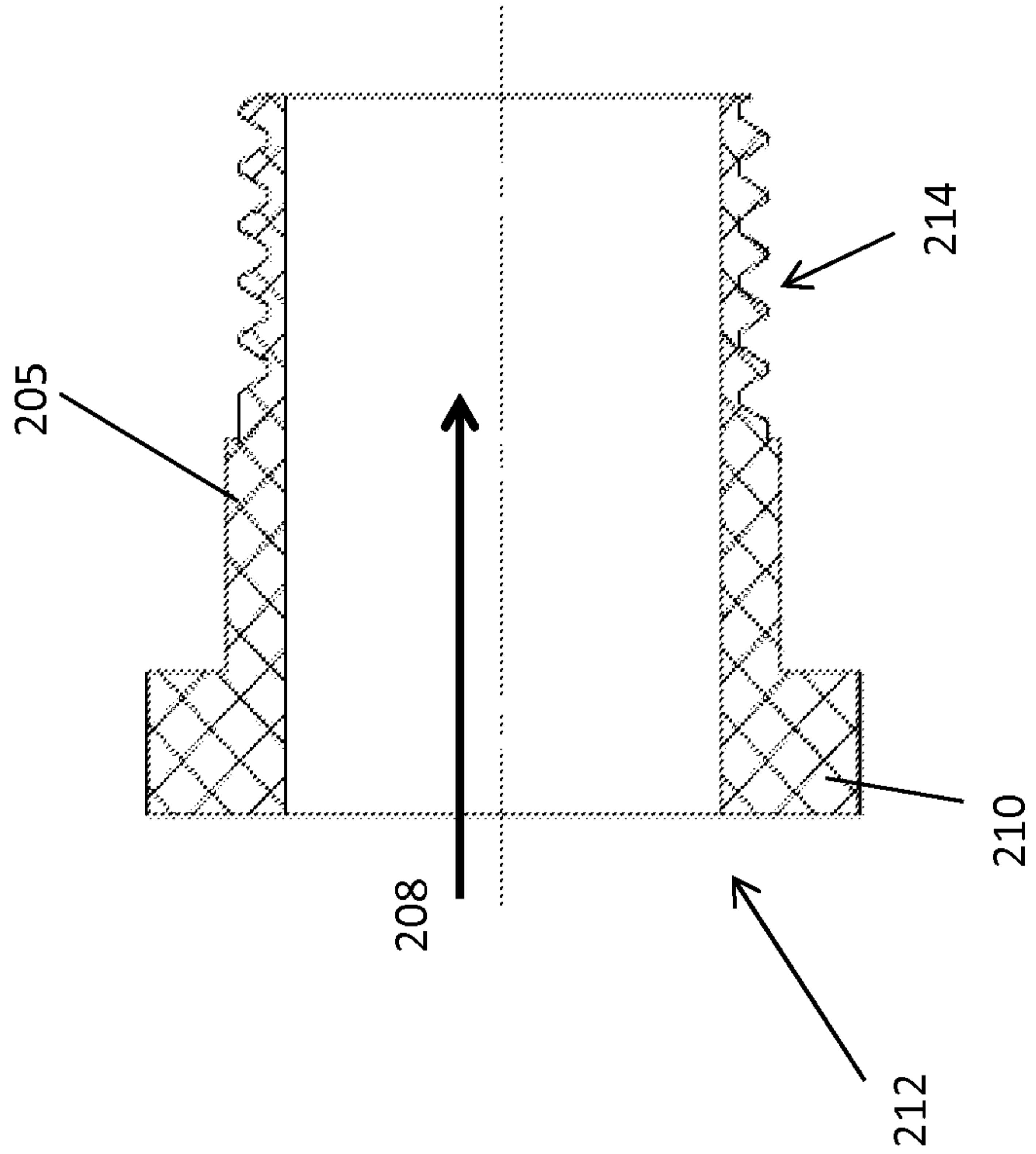

Fig. 8

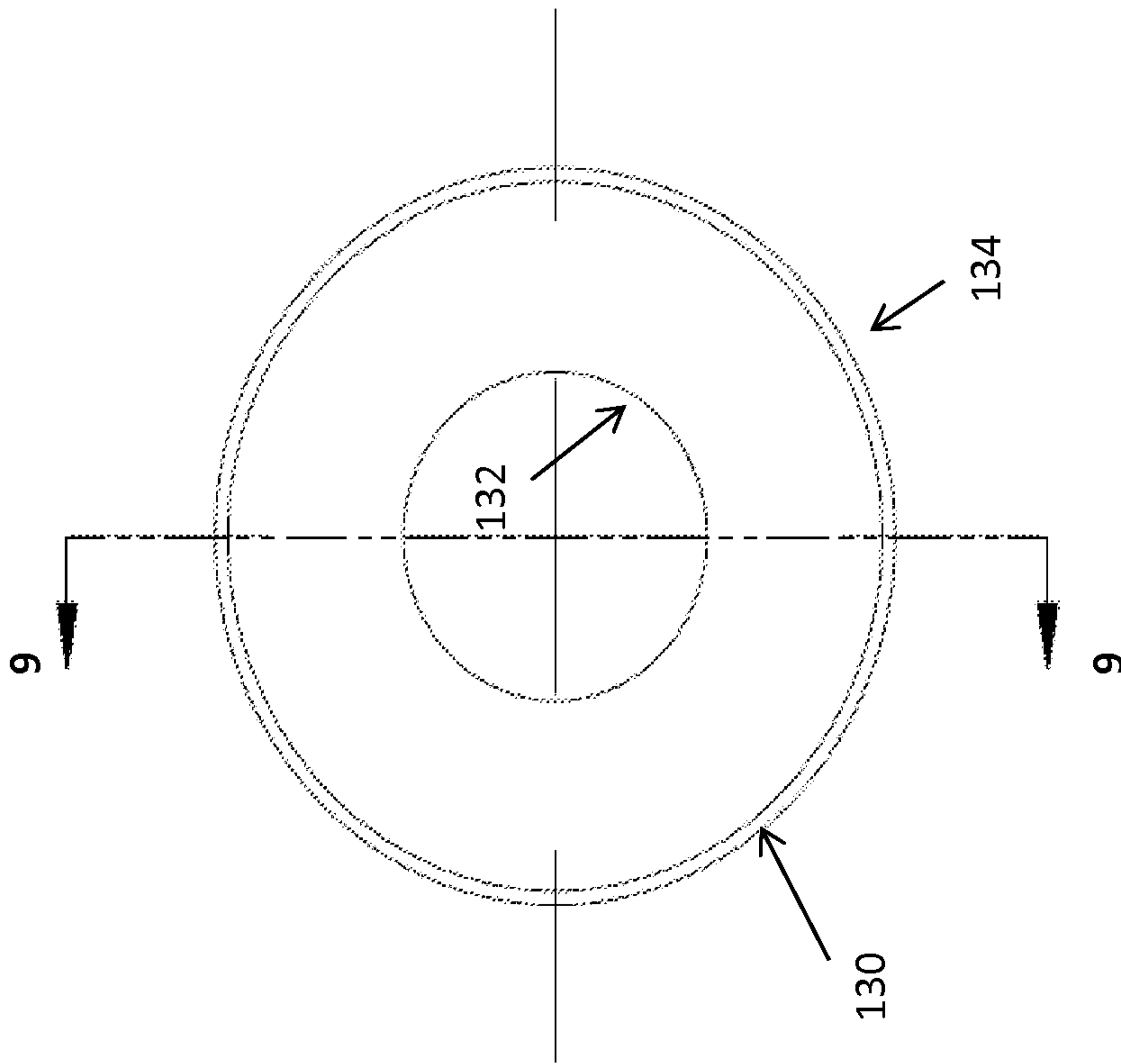

Fig. 9

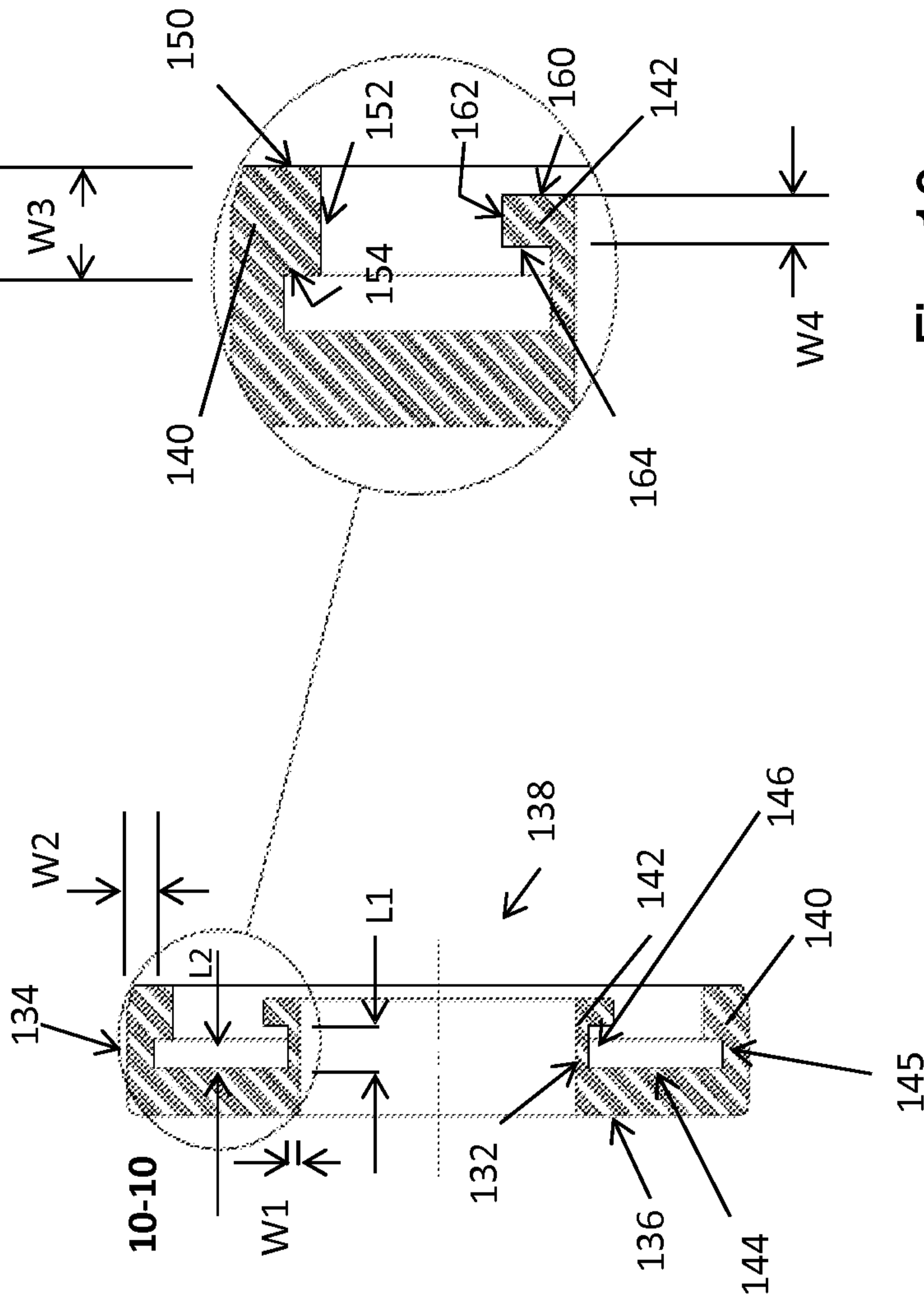

Fig. 10

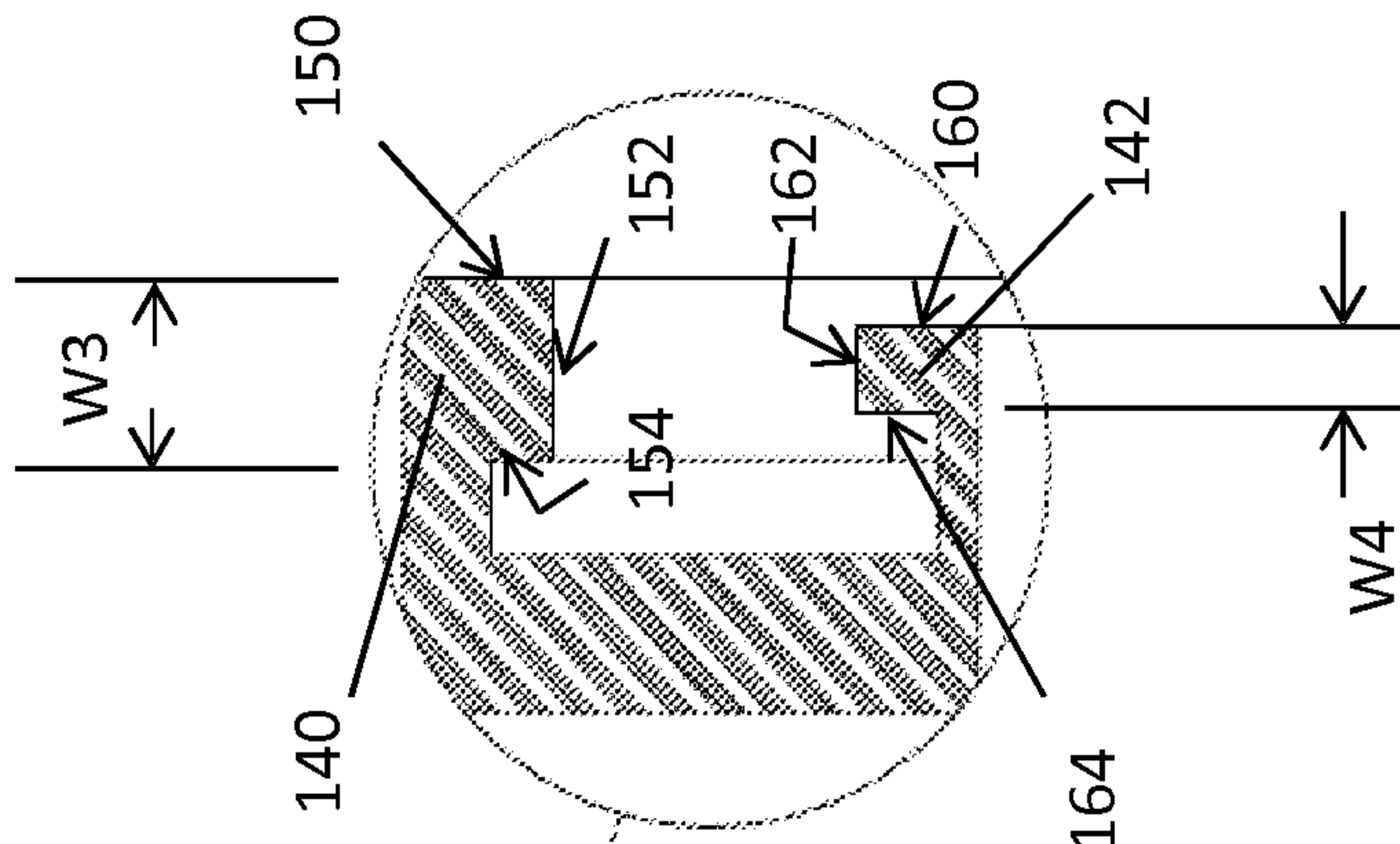

Fig. 12

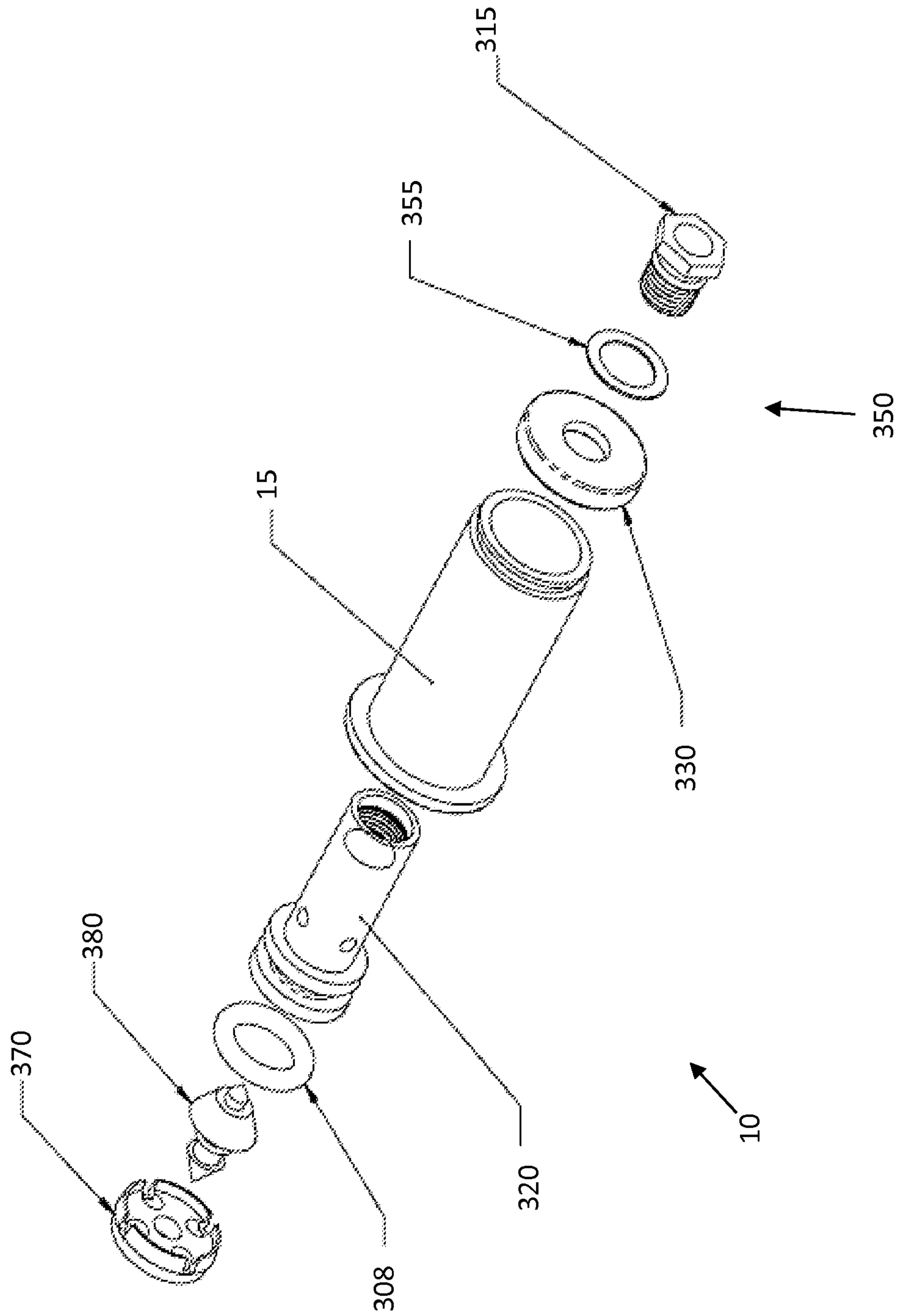

Fig. 13

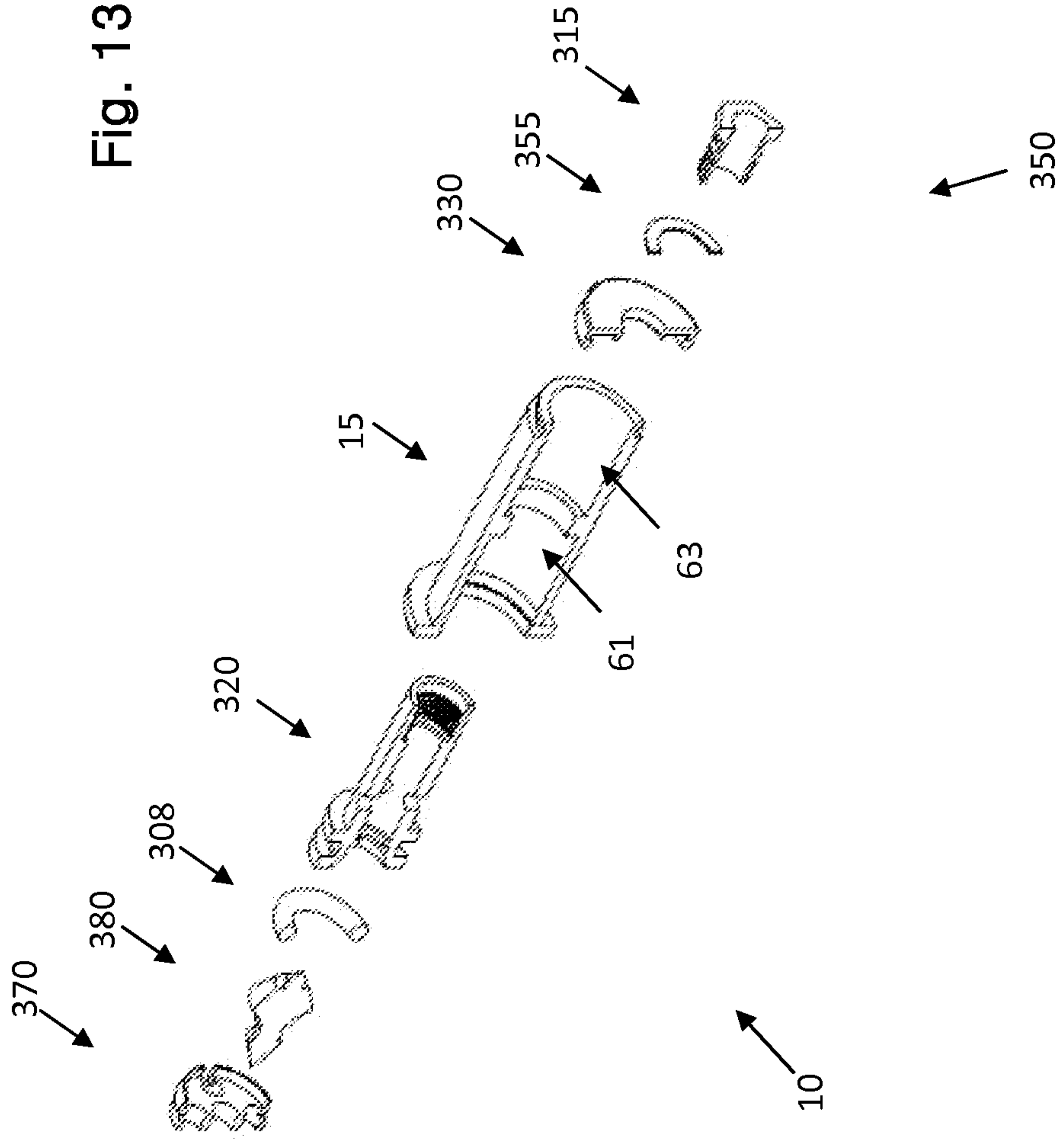

Fig. 14

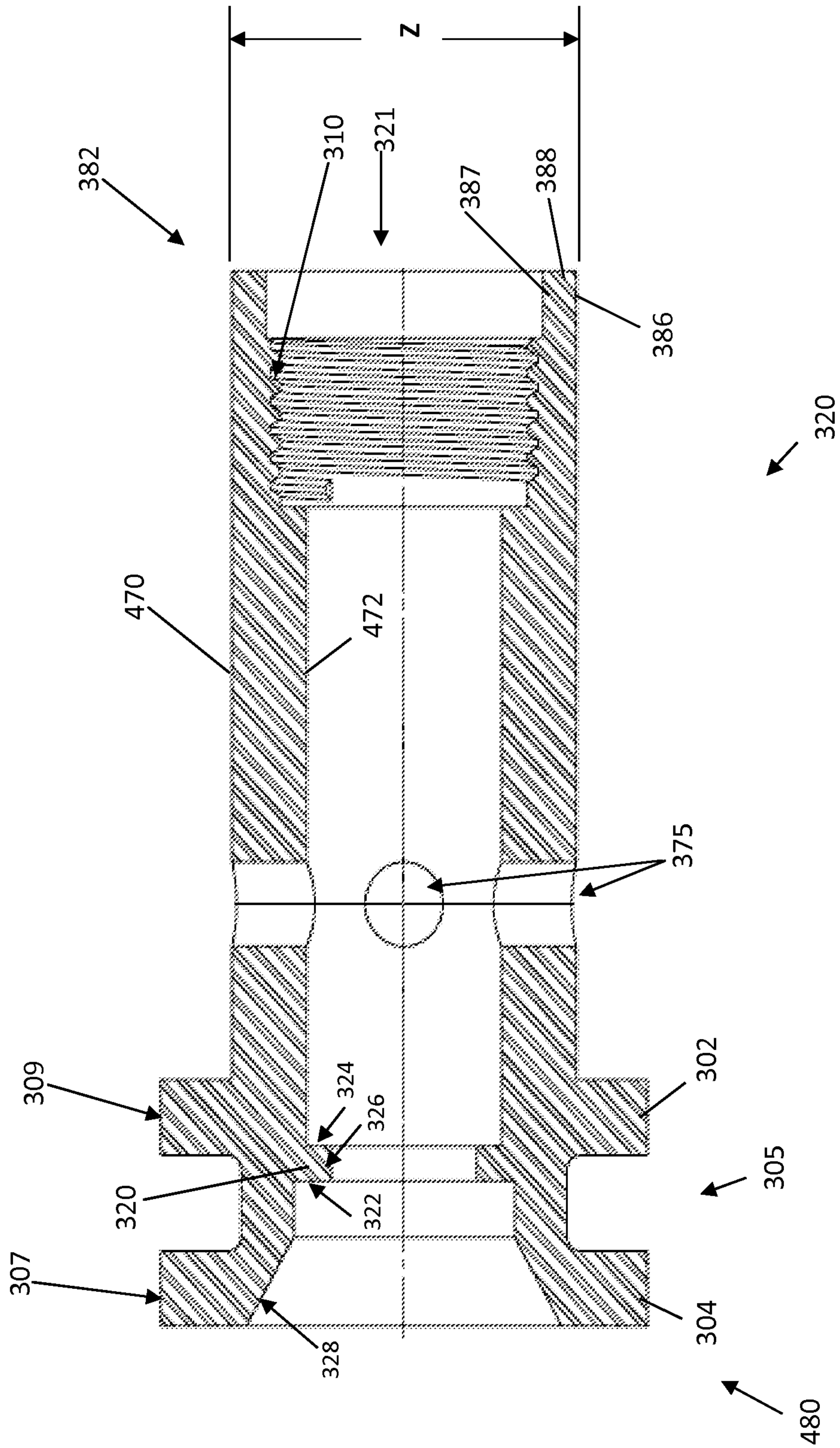

Fig. 15

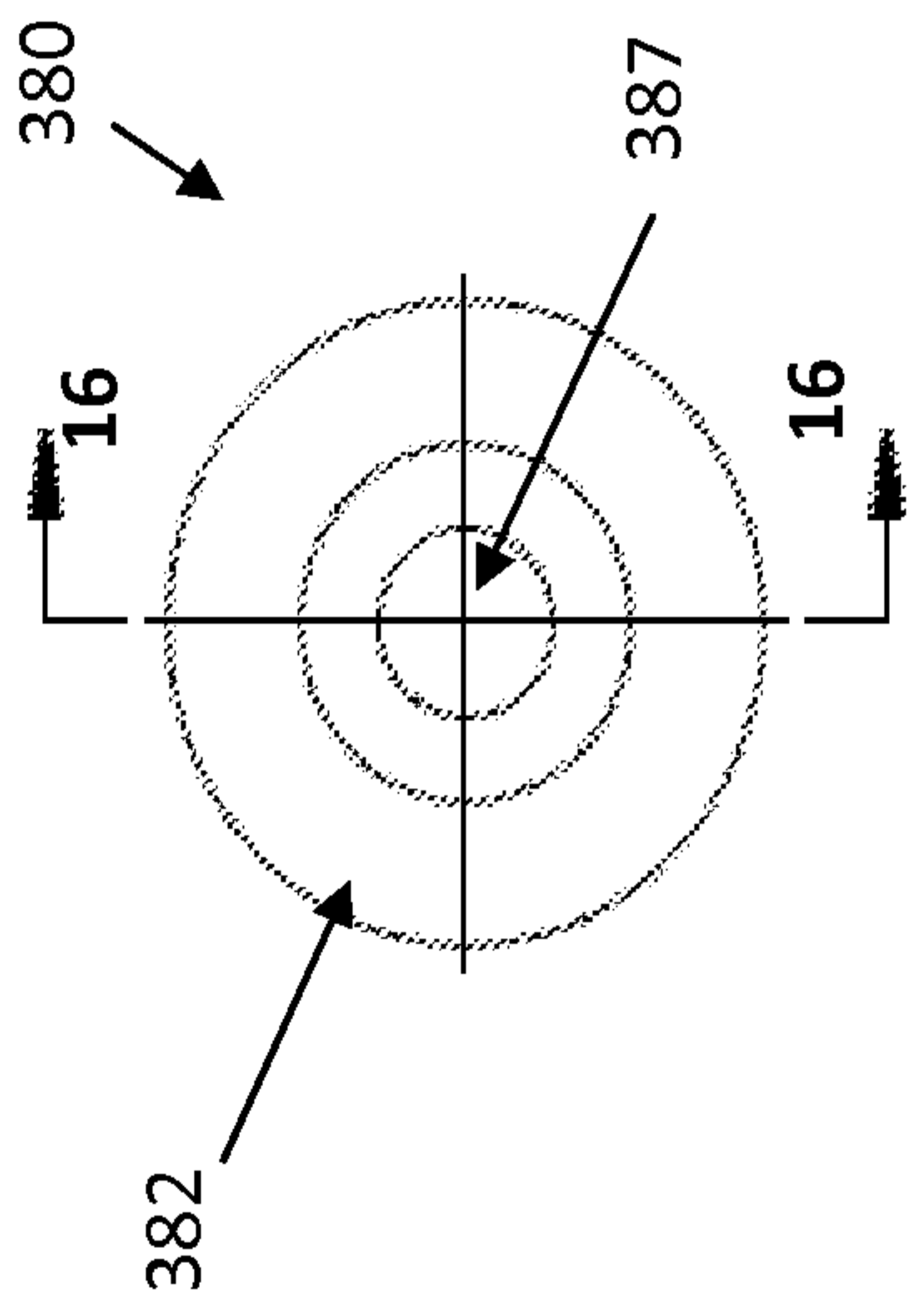

Fig. 16

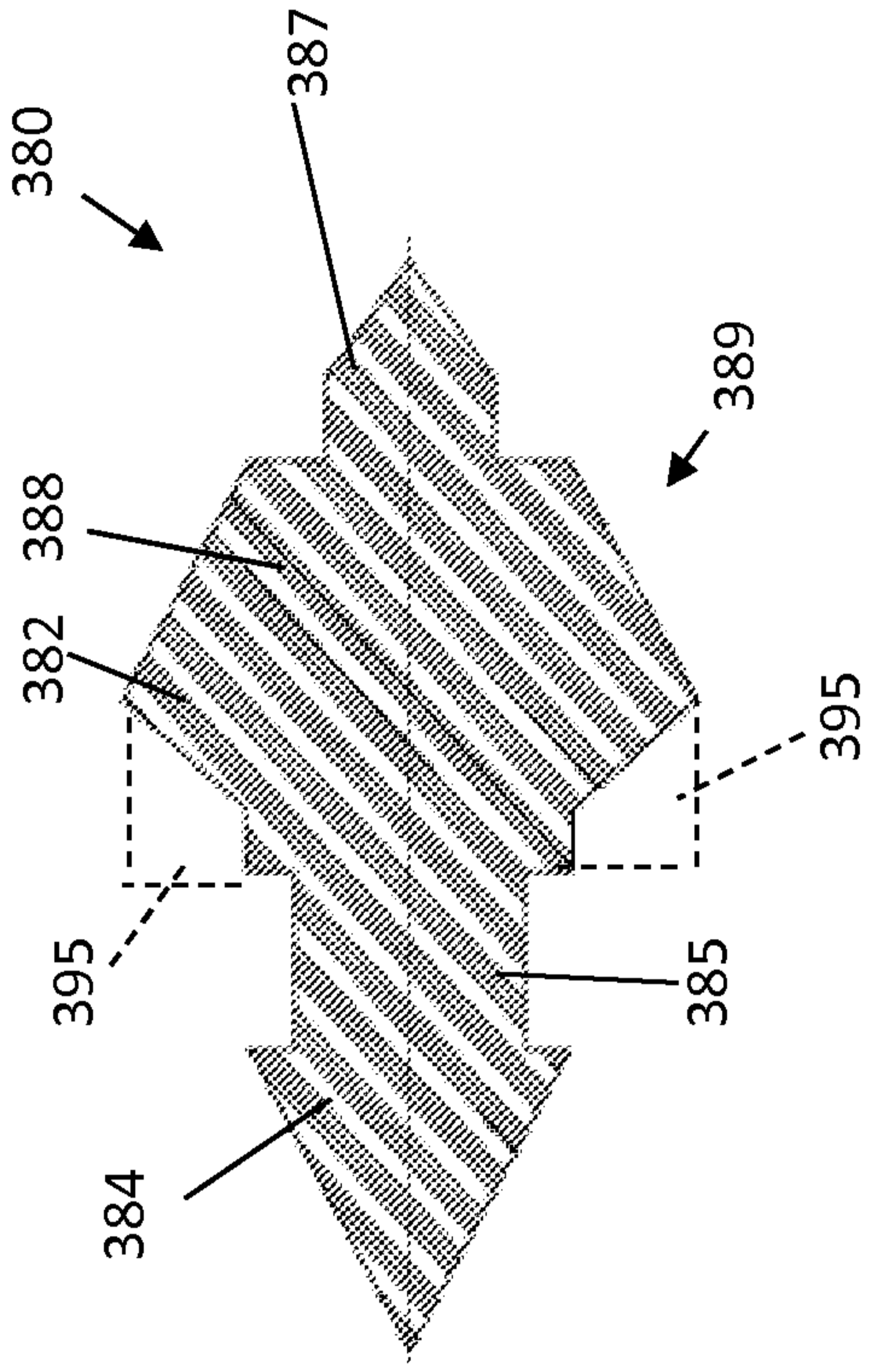

Fig. 17A

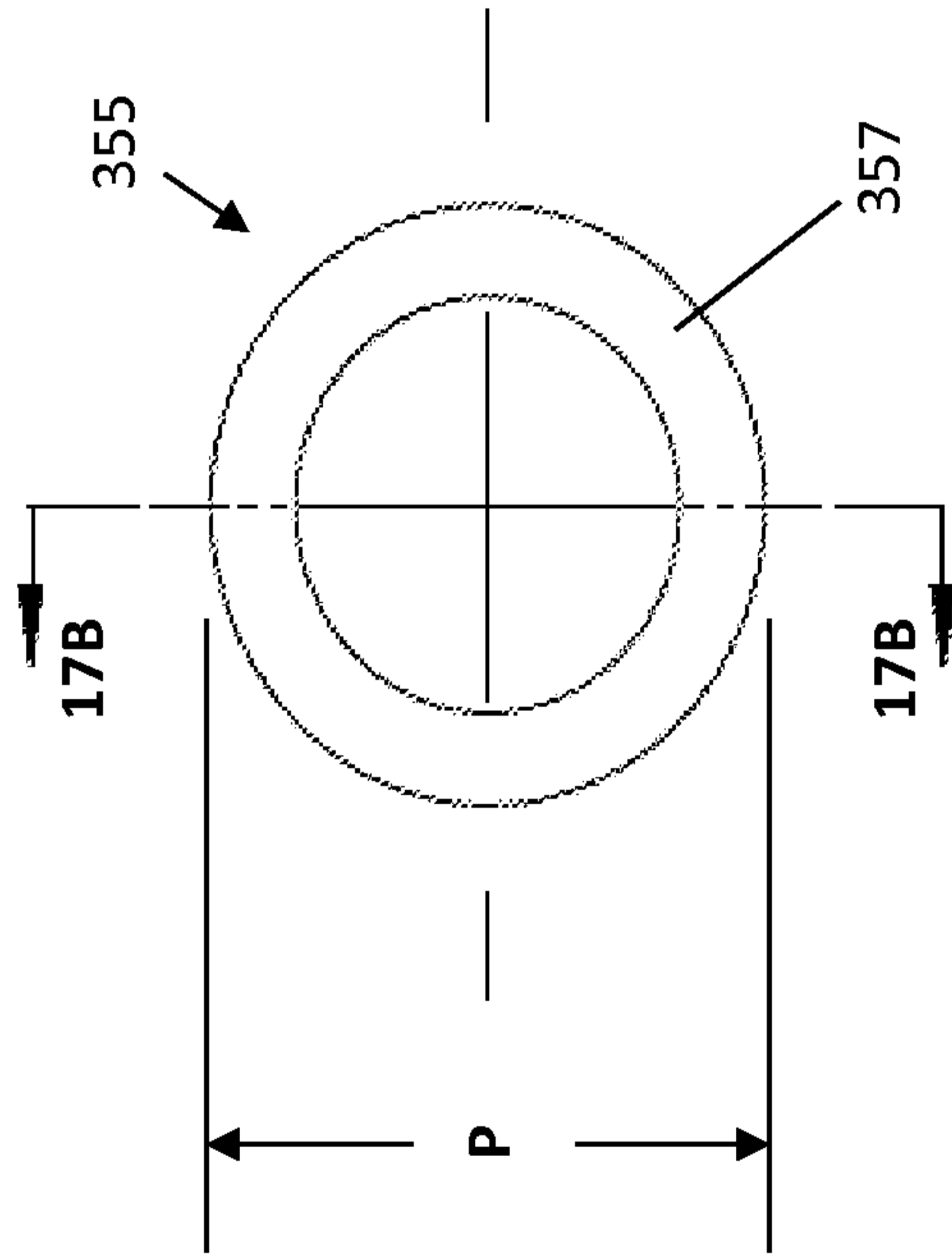

Fig. 17B

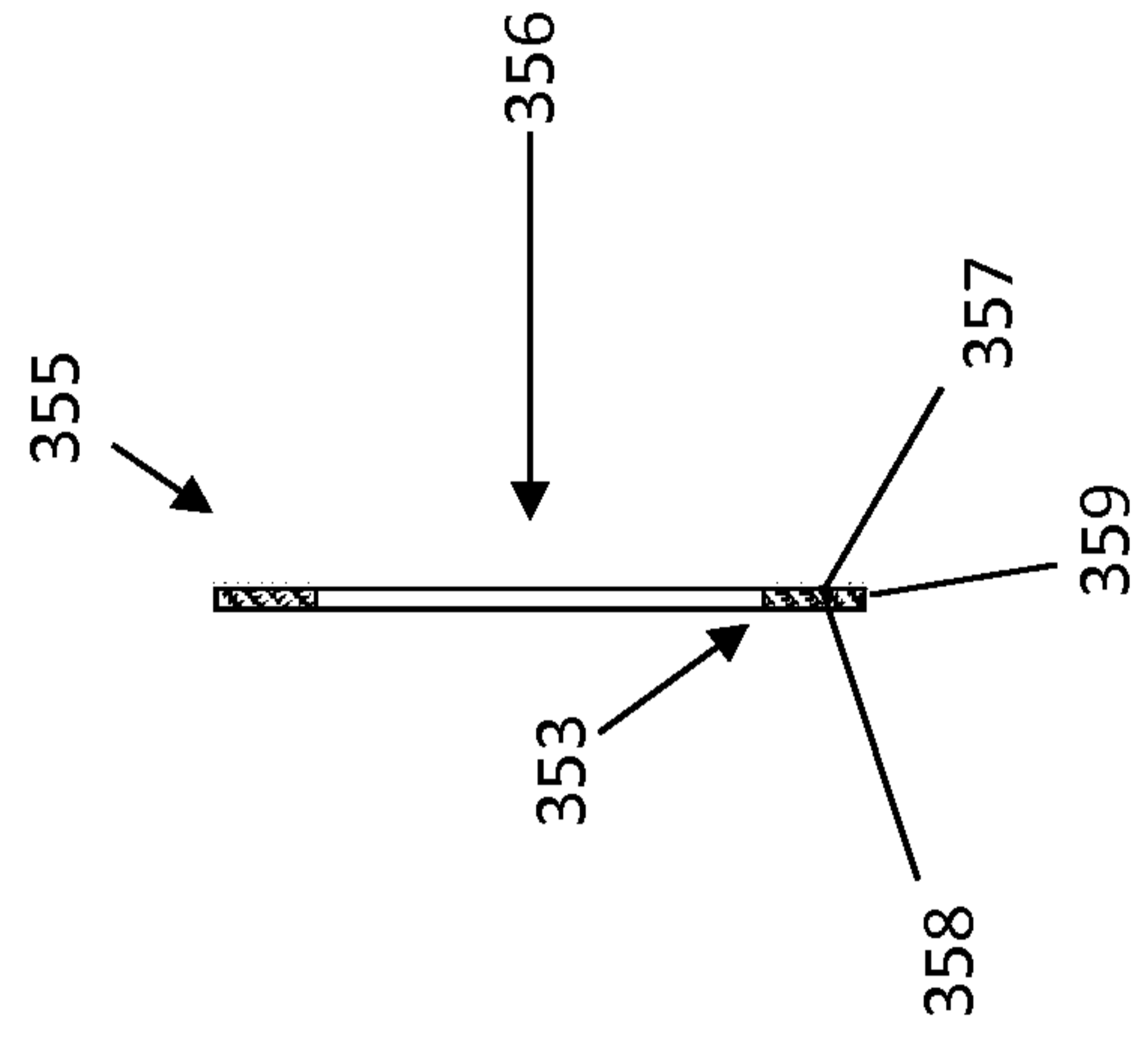

Fig. 18A

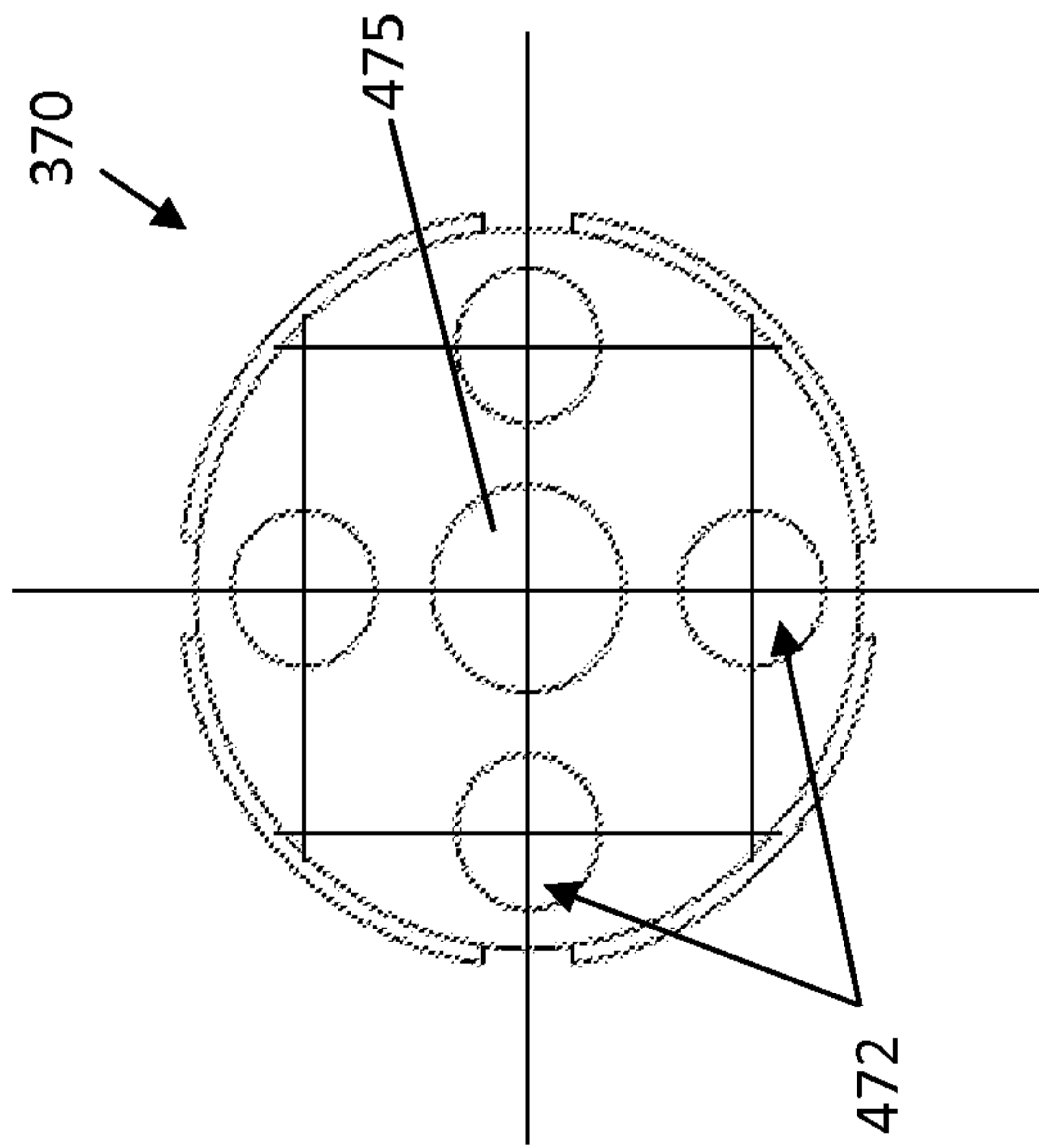

Fig. 18B

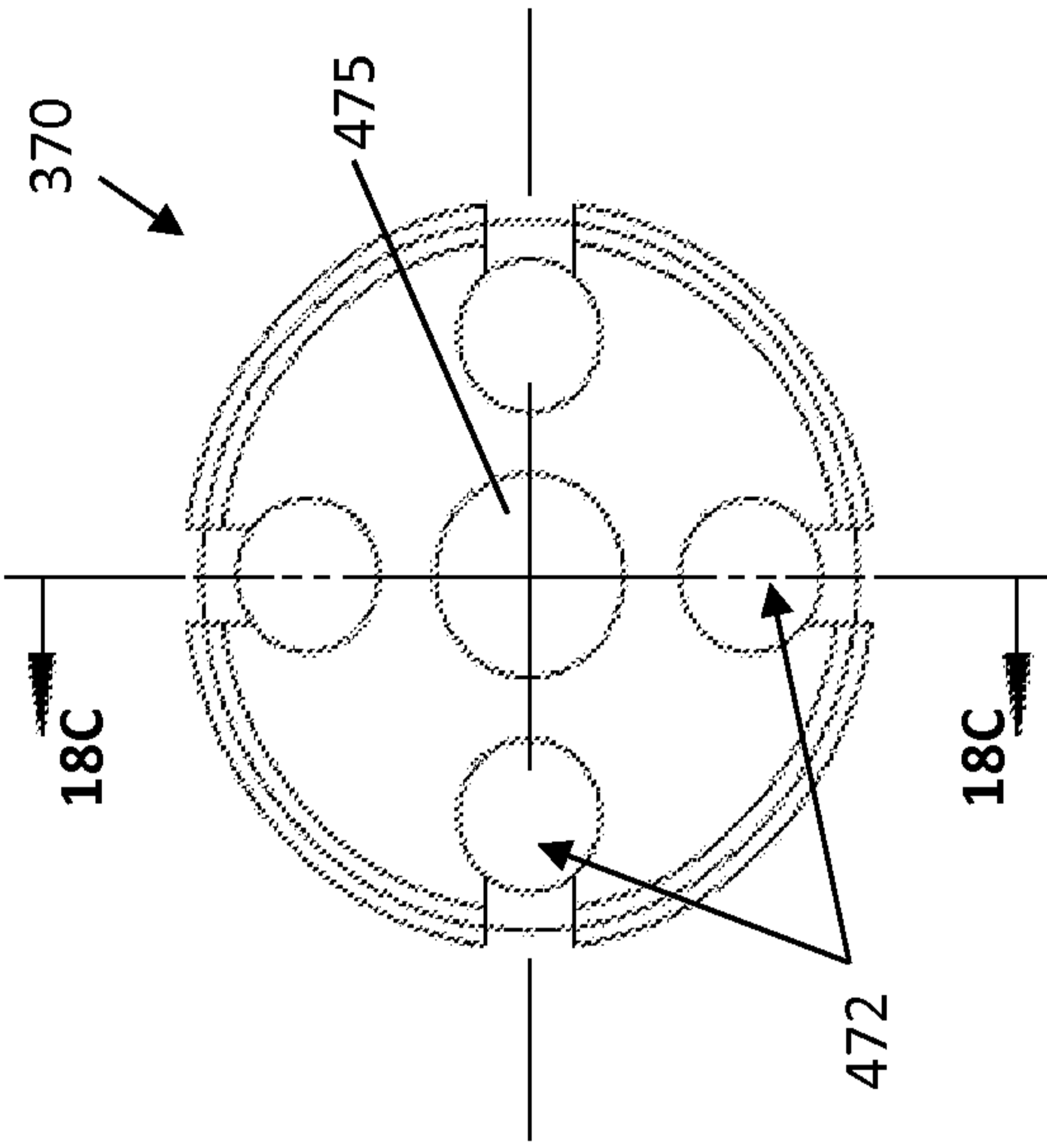

Fig. 18C

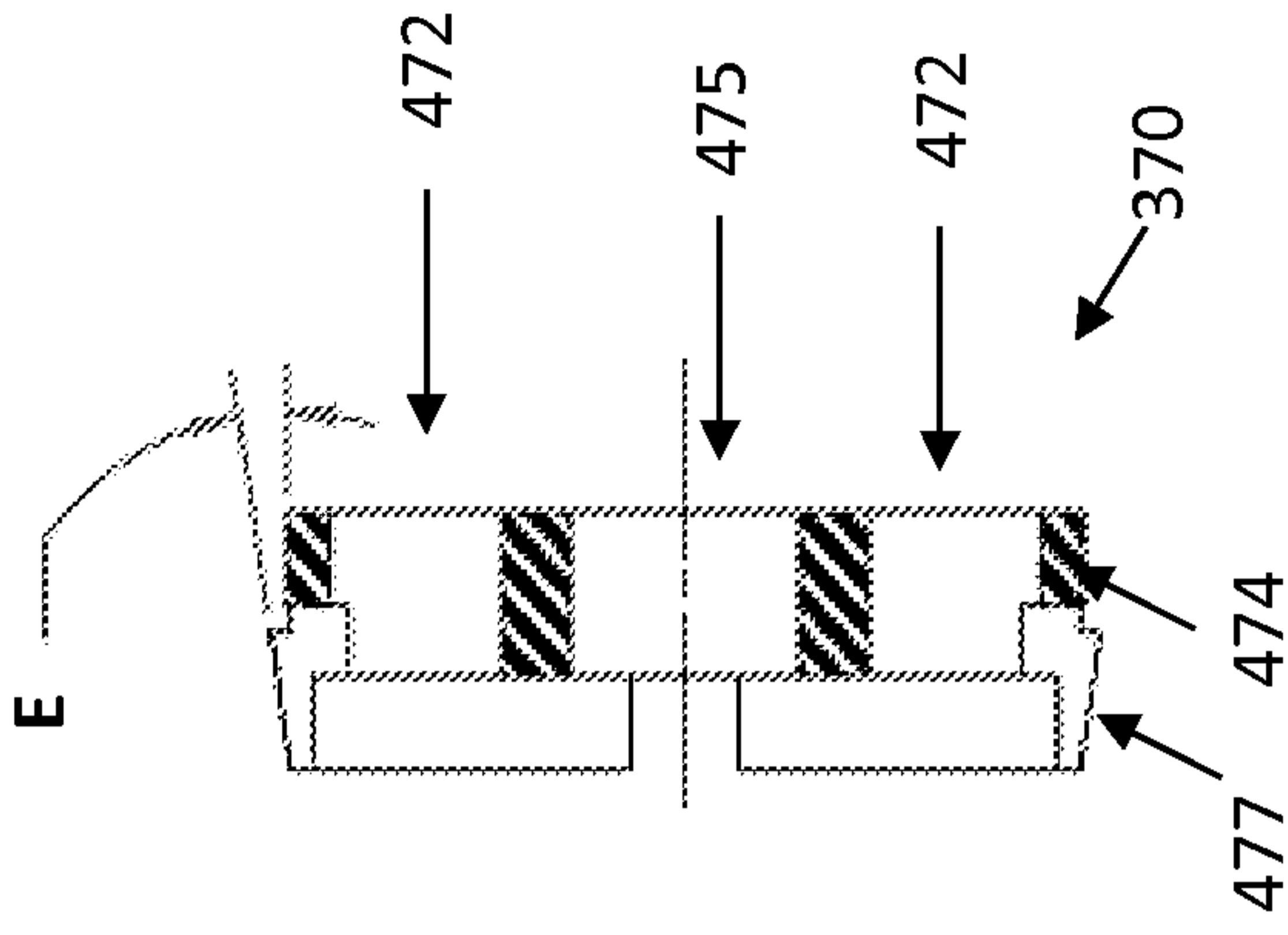

Fig. 19A

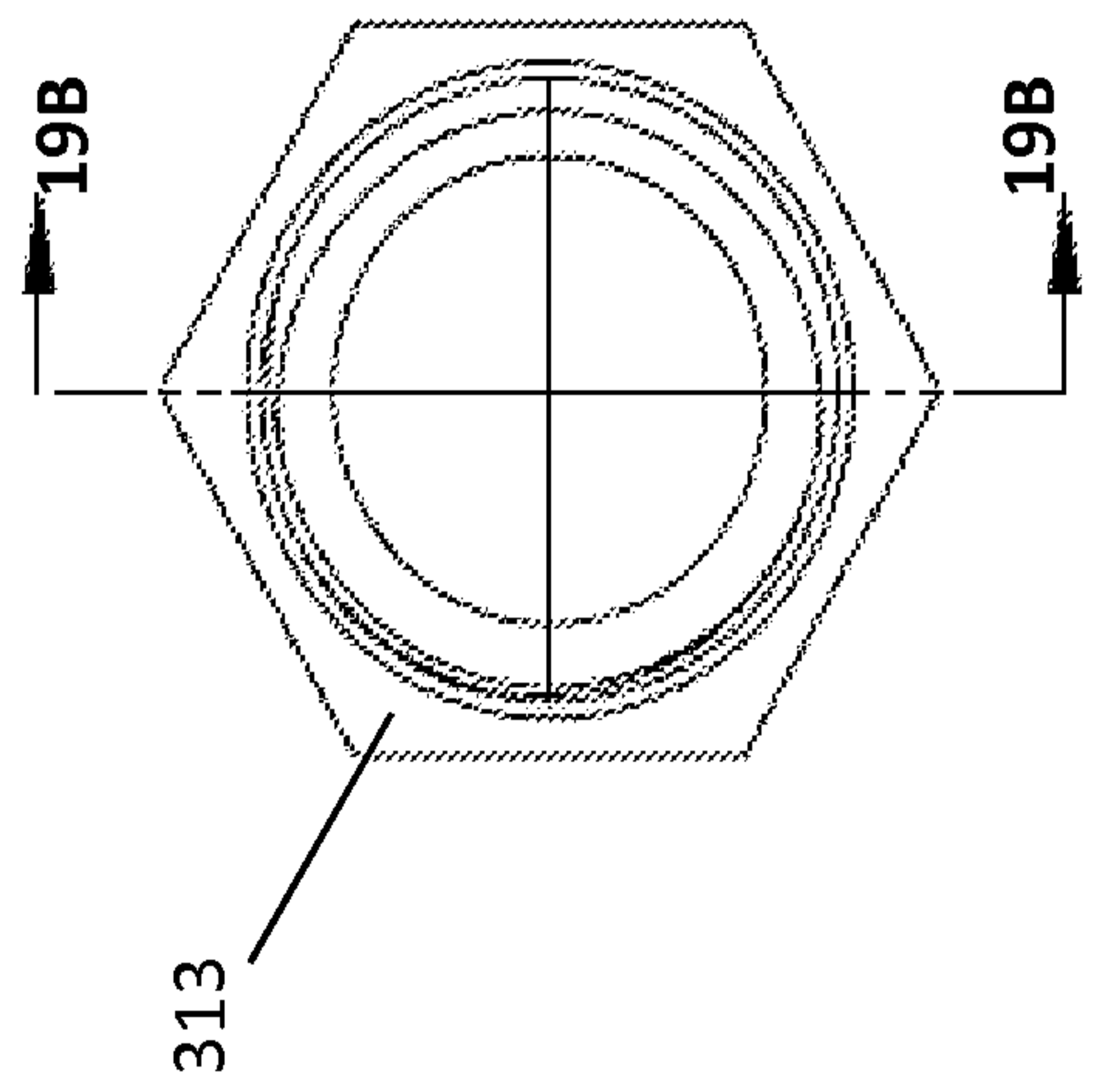
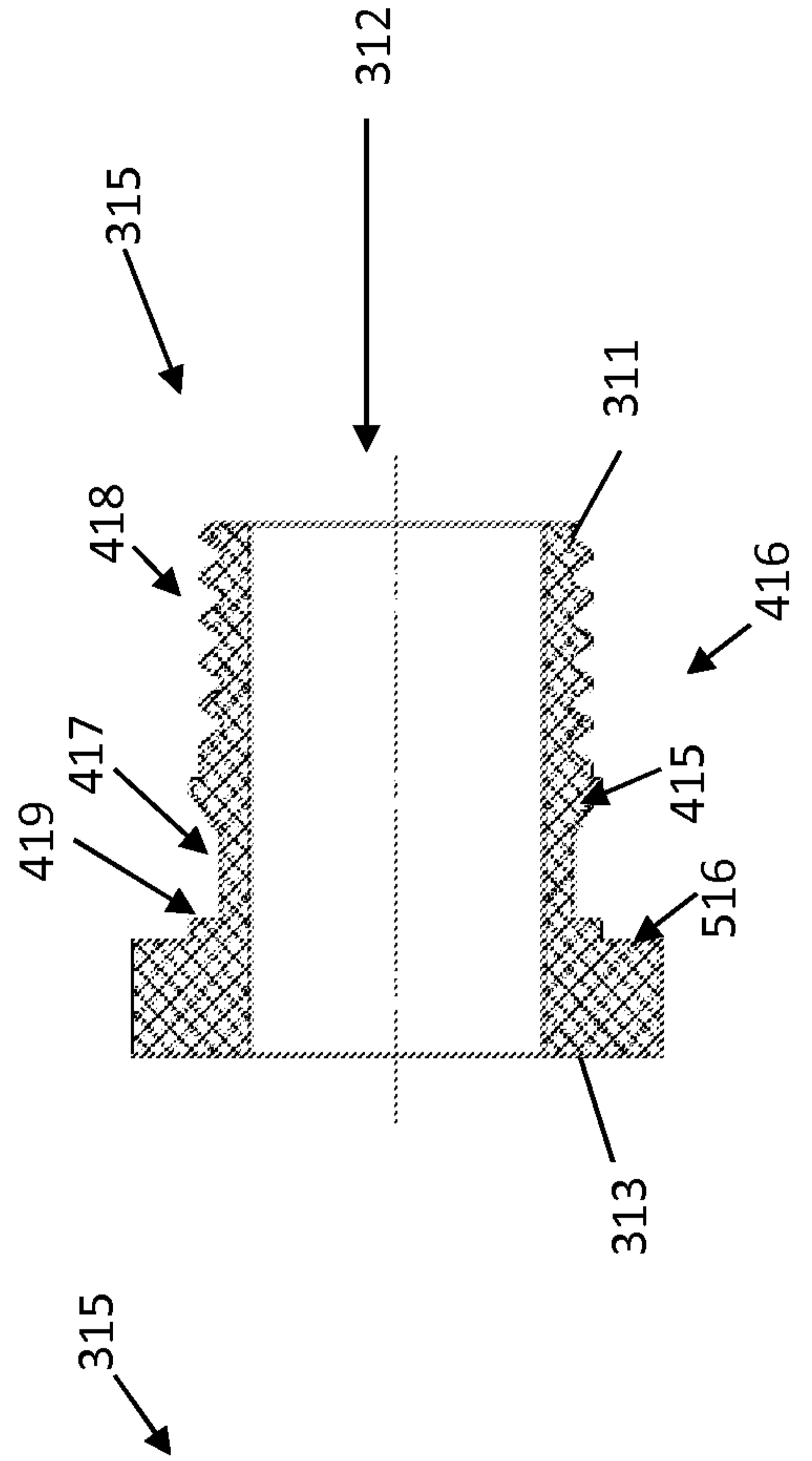

Fig. 19B



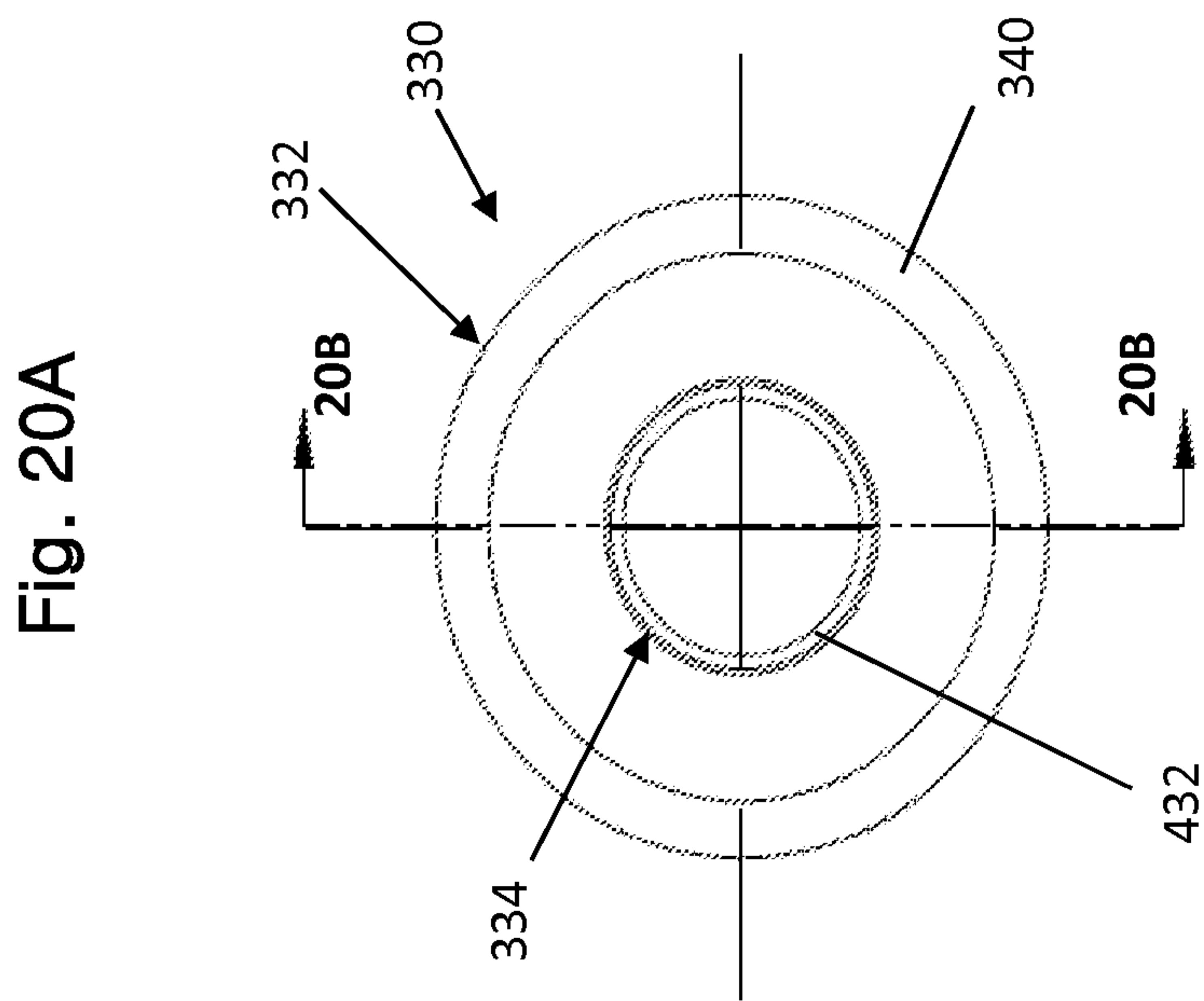

Fig. 20B

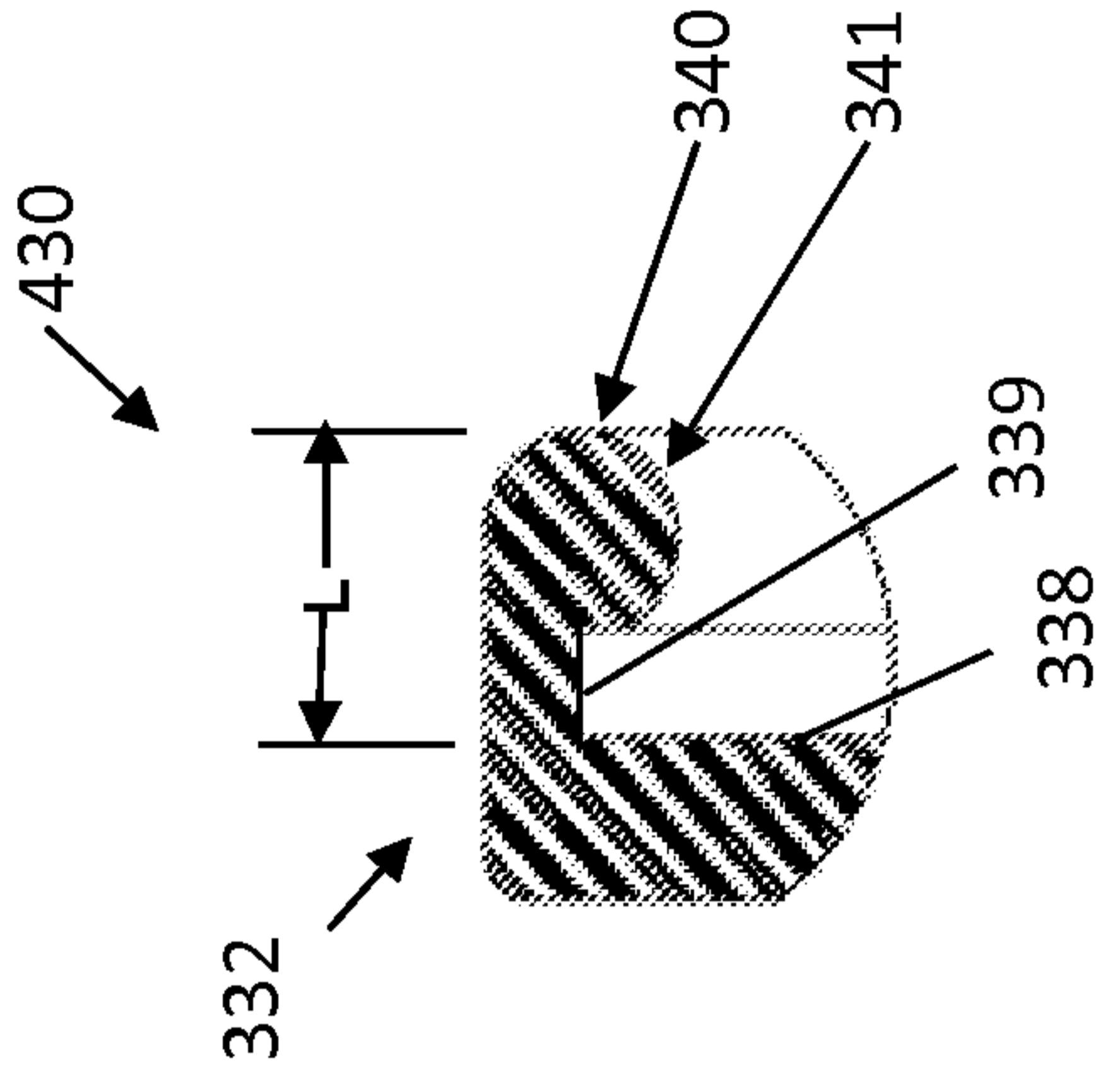

Fig. 20C

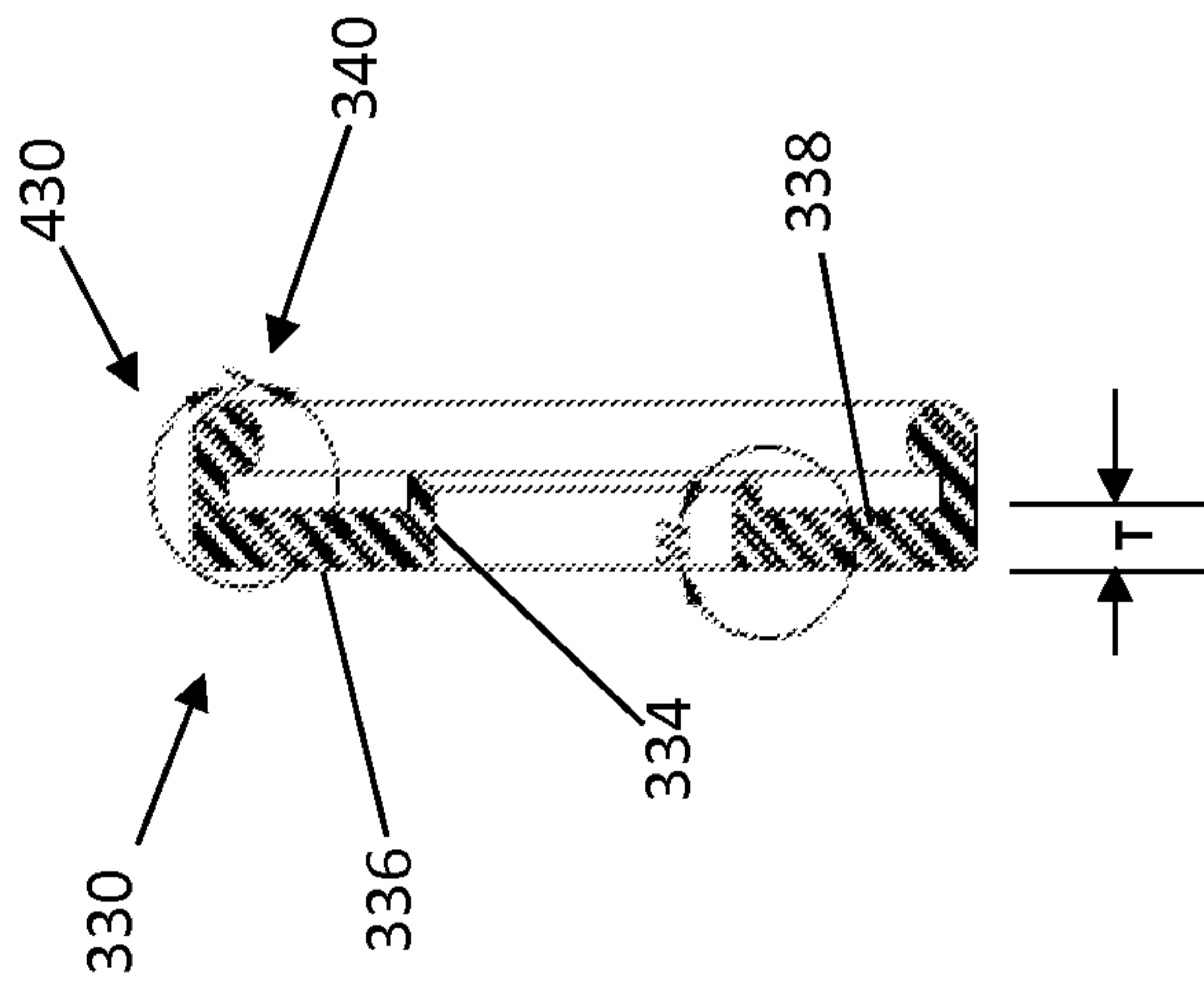
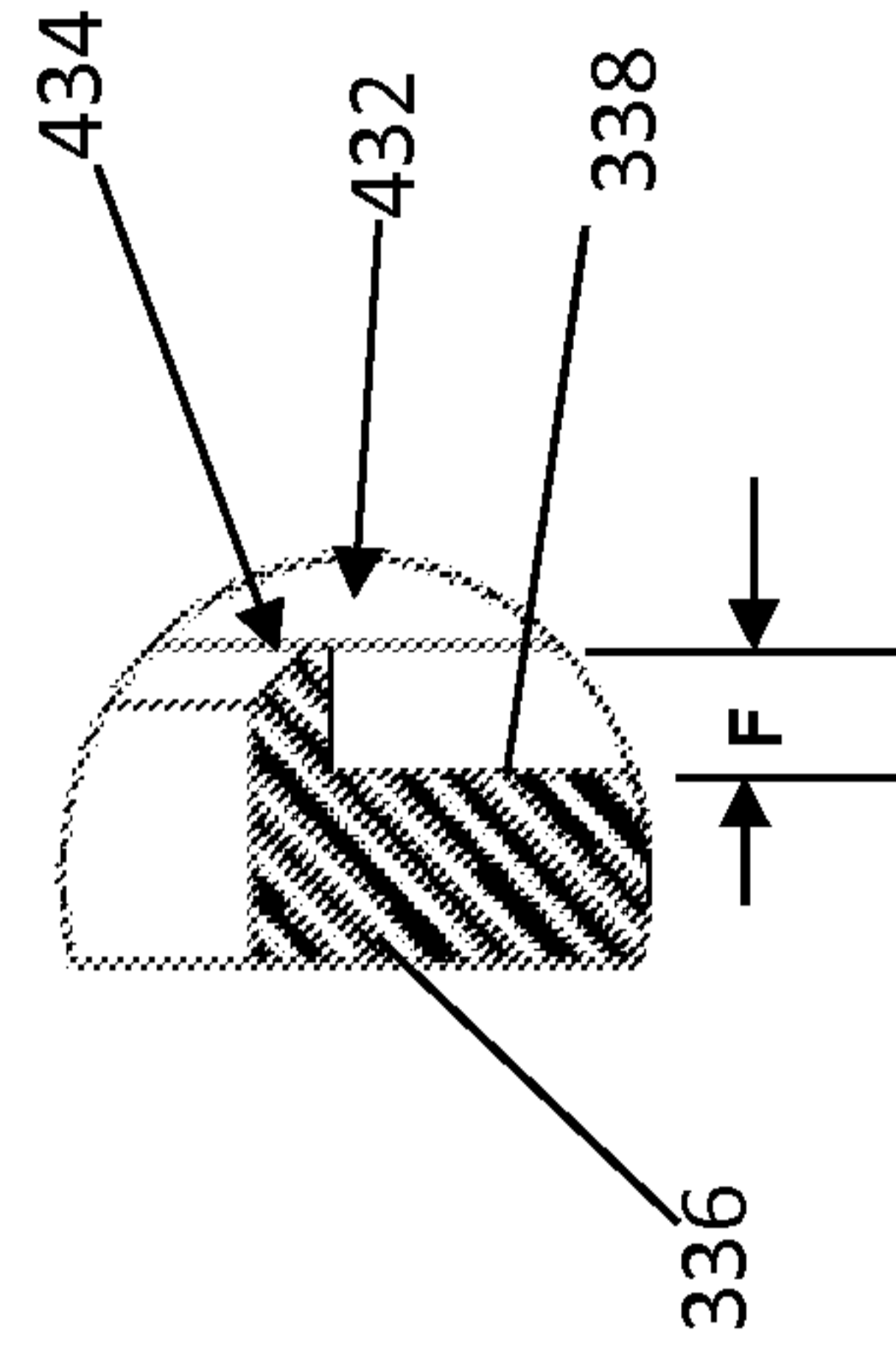

Fig. 20D



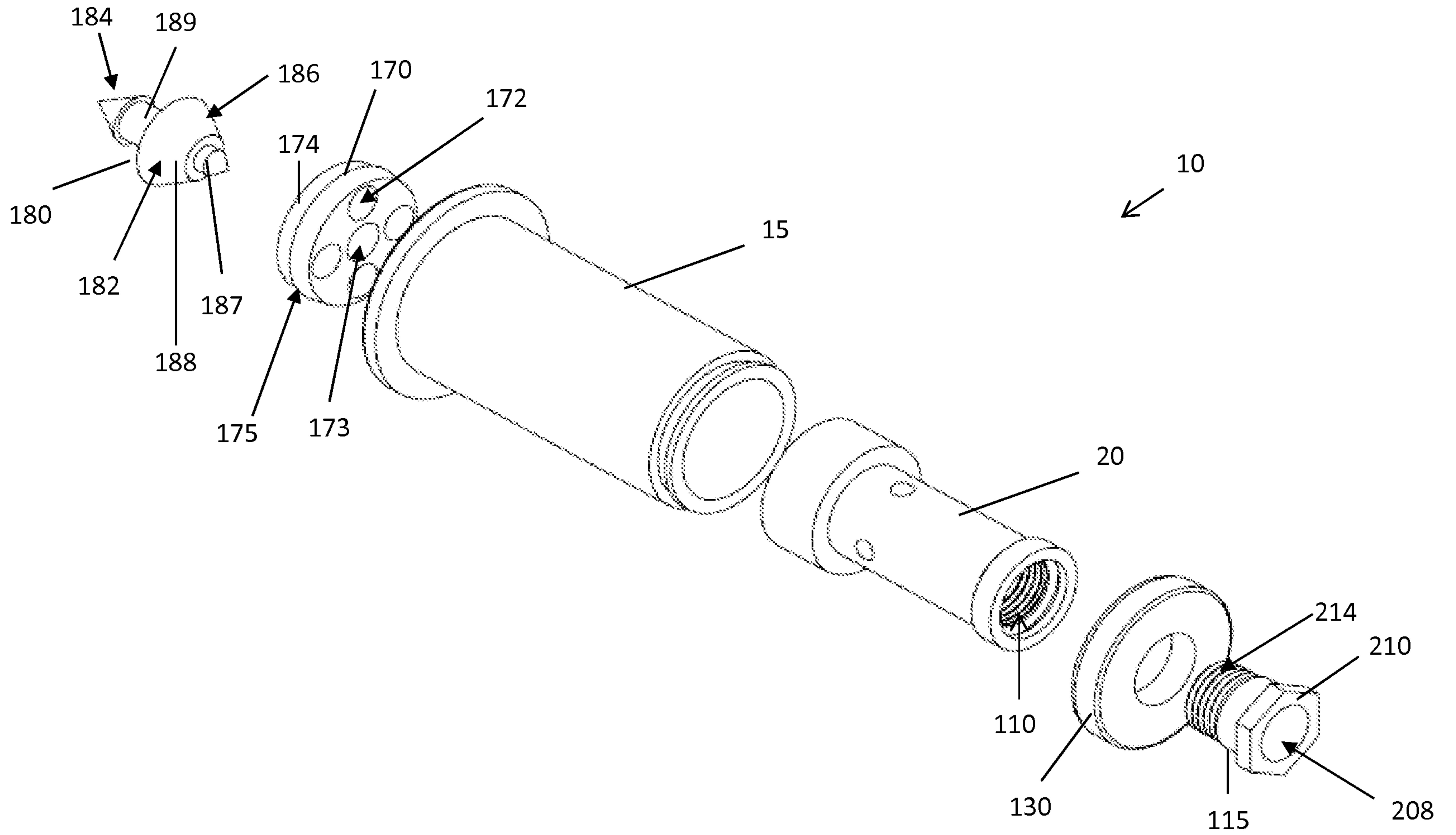

Fig. 1