



- (51) International Patent Classification:
A61M 1/36 (2006.01) A61M 39/22 (2006.01)
A61M 39/16 (2006.01)
- (21) International Application Number:
PCT/IT2013/000011
- (22) International Filing Date:
15 January 2013 (15.01.2013)
- (25) Filing Language: Italian
- (26) Publication Language: English
- (30) Priority Data:
RM2012A000013 16 January 2012 (16.01.2012) IT
- (72) Inventor; and
- (71) Applicant : GRANDOLFO, Nicola [IT/IT]; Corso Vittorio Emanuele, 51/A, I-70019 Triggiano (BA) (IT).
- (74) Agent: CICCARELLO, Basilio; Ingeniis s.a.s., Di Basilio Ciccarello e C., Via Antonio De Berti, 24, I-00143 Roma (IT).
- (81) Designated States (unless otherwise indicated, for every kind of national protection available): AE, AG, AL, AM, AO, AT, AU, AZ, BA, BB, BG, BH, BN, BR, BW, BY,

BZ, CA, CH, CL, CN, CO, CR, CU, CZ, DE, DK, DM, DO, DZ, EC, EE, EG, ES, FI, GB, GD, GE, GH, GM, GT, HN, HR, HU, ID, IL, IN, IS, JP, KE, KG, KM, KN, KP, KR, KZ, LA, LC, LK, LR, LS, LT, LU, LY, MA, MD, ME, MG, MK, MN, MW, MX, MY, MZ, NA, NG, NI, NO, NZ, OM, PA, PE, PG, PH, PL, PT, QA, RO, RS, RU, RW, SC, SD, SE, SG, SK, SL, SM, ST, SV, SY, TH, TJ, TM, TN, TR, TT, TZ, UA, UG, US, UZ, VC, VN, ZA, ZM, ZW.

- (84) Designated States (unless otherwise indicated, for every kind of regional protection available): ARIPO (BW, GH, GM, KE, LR, LS, MW, MZ, NA, RW, SD, SL, SZ, TZ, UG, ZM, ZW), Eurasian (AM, AZ, BY, KG, KZ, RU, TJ, TM), European (AL, AT, BE, BG, CH, CY, CZ, DE, DK, EE, ES, FI, FR, GB, GR, HR, HU, IE, IS, IT, LT, LU, LV, MC, MK, MT, NL, NO, PL, PT, RO, RS, SE, SI, SK, SM, TR), OAPI (BF, BJ, CF, CG, CI, CM, GA, GN, GQ, GW, ML, MR, NE, SN, TD, TG).

Published:
— without international search report and to be republished upon receipt of that report (Rule 48.2(g))

(54) Title: EXTERNAL END DEVICE FOR PERMANENT CATHETERS SUITABLE FOR ISOLATING A LIQUID FLOW

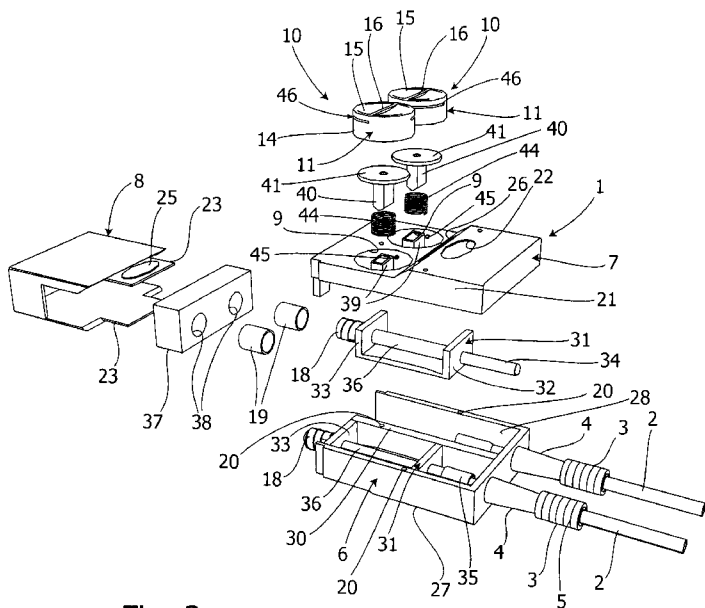

Fig. 2

(57) Abstract: An external end device for permanent catheters suitable for isolating a liquid flow from the environment has a body (1) connectable on one side to two catheters (2, 2), and on the other side to a closure lid (8) or a treatment equipment. Provided in the body (1) are two valves interrupting the liquid flow in the two catheters, in the form of so-called pinch valves (10, 10), the body (1) having a base element (6) housing two elastic tubes (36, 36) acting as pinch valve sleeves that are compressible until the closure of their lumen and are situated downstream of their respective catheters (2, 2) and upstream of the respective connectors (18, 18), and a covering element (7) containing two flow control units (10, 10) for said pinch valves in such a position to interact with the two elastic tubes (36, 36) in order to achieve their closure and opening by pinching and releasing them, respectively.



EXTERNAL END DEVICE FOR PERMANENT CATHETERS SUITABLE FOR ISOLATING A LIQUID FLOW

Technical field

- 5 The present invention relates to an external end device for permanent catheters suitable for isolating a flow of blood or other liquid from the environment, that is useful for example in hemodialysis, peritoneal dialysis and chemotherapy.

Background art

- 10 The Patent Application No. PCT/IT2010/000269 of the same Applicant discloses an external end device for permanent catheters, comprising a container that can be connected on one side to two catheters, and on the other side to a closure lid containing a disposable absorbent material impregnated by an antiseptic substance. Such a container houses two taps being provided with
- 15 knobs operable from outside of the container. The two taps have, on one side, first connectors for the connection to the catheters and, on the other side, second connectors projecting from the container for the connection to an external equipment. The first connectors are connected to the catheters that exit the container through at least a flexible supporting tube section, connected
- 20 in turn to the container. The supporting tube section holds externally a cuff designed to be positioned in the subcutaneous tissue of the patient's body. The second connectors are provided with caps surrounded by the disposable absorbent material that is received in the closure lid. The closure lid makes the absorbent material adhere to the caps, and covers the caps for protecting them
- 25 externally from a bacterial attack by means of the antiseptic substance by which the absorbent material is impregnated.

- The knobs positioned outside the container operate the taps connected to the catheters. Each tap drives a ball inside a respective duct connected to the catheter, for opening and closing the blood flow when necessary. Thus the ball
- 30 is a foreign object in contact with the blood, and there is a risk that what must be aseptic can be attacked by pathogens. Stresses on the blood that are

caused by the contact with the ball and by the flow interruption should not be undertaken.

Summary of the invention

The present invention aims at overcoming the above mentioned drawbacks and
5 troubles.

An object of the invention is to provide an external end device for permanent catheters that optimises the insulation of the catheters as well as the opening and closing means thereof from the external environment, and then to prevent pathogen attacks.

10 Another object of the invention is to reduce friction stresses and shear stress, that the blood undergoes when passing through a valve, e.g. a ball valve, and when the blood flow is interrupted by the ball.

Further an object of the invention is to provide an external end device that allows the real closed position of its taps to be checked.

15 For achieving the above objects, the invention provides an external end device for permanent catheters for isolating a flow of a liquid from the environment, the end device comprising a body that can be connected on one side to two catheters, and on the other side to either a closure lid if there is no flow or to connectors for a external treatment equipment when there is a flow, and two
20 pinch valves for interrupting the liquid flow in the two catheters.

Brief description of drawings

Further features and advantages will be more evident in the present description of a preferred and not exclusive embodiment of an external end device for permanent catheters for isolating a flow of a liquid from the
25 environment shown by way of an example and not limiting way with the aid of the enclosed drawing sheets in which:

Figure 1 shows a general perspective view of a embodiment of the device according to the invention, in a closed position;

Figure 2 shows an exploded perspective view of the device in Figure 1;

30 Figure 3 shows a longitudinally cross-sectioned partially exploded perspective view of the device in Figure 1;

Figure 4 shows an exploded side view of the device in Figure 1; and
Figure 5 shows an enlarged view of components of the device in Figure 2.

Detailed description of embodiment

Referring to Figure 1 that is a general perspective view of a embodiment of the
5 device according to the invention, in a closed position, i. e. when there is no
liquid flow, a body of the device connected to two catheters 2, 2 is indicated as
1. Two subcutaneous cuffs are designated as 3, 3 that surround two
supporting tube sections 4, 4 projecting from the device body 1 and connected
thereto. According to another not shown embodiment the pair of catheters can
10 be replaced by one dual lumen catheter, i.e. having two ways.

For convenience same reference numerals are used for indicating equal parts
and in the following the description of the features of a part is implicitly valid
also for the other identical part. Indicated as 5 in the subcutaneous cuffs is a
silver wire emerging from the subcutaneous cuff 3 for a katadyn effect or
15 purification by katadyn process, as known.

The body 1 comprises a base element 6 and a covering element 7. Indicated as
8 is a closure lid for the body 1. The body 1 in its side opposite to two
catheters 2, 2 is closed, when there is no liquid flow, by means of the closure
lid 8, as shown in Figure 1. Otherwise, when there is a liquid flow, the body 1
20 has connectors as seen in the following figures, for the connection to a not
shown external treatment equipment.

In Figure 2 that is an exploded perspective view of the device in Figure 1, the
base element 6 is shown separated from the covering element 7 and the
closure lid 8.

25 Formed in the covering element 7 are cylindrical seats 9, 9 and flow control
units 10, 10, which are housed therein. The flow control units 10, 10 together
with the elastic tubes, which are housed in the base element 6 and described
in the following, form so-called pinch valves. The flow control units 10, 10
comprise knobs 11, 11 having a side wall 14 and a top 15. Formed on the top
30 15 are recesses for creating a diameter ridge 16 for an easy grip of the knobs
11, 11 for their rotation. The diameter ridges 16 indicate also the open-closed

position respectively, of the pinch valves. As shown in the following figures a pin 17 is hanging from the top 15, inside each knob 11.

In their side facing an external treatment equipment not shown in the figures, as already said, the pinch valves have connectors 18, 18, for example Luer Lock, provided with caps generally indicated as 19. The covering element 7 is
5 fixed to the base element 6, for example by screws in holes 20.

Formed in a raised portion 21 of the covering element 7 is an elliptical-shaped upper cut-out 22 to allow the closure lid 8 to be snap hooked. For this purpose, the closure lid 8 has a pair of plates 23, 23, singularly bearing a portion 25
10 projecting outside. When the closure lid 8 engages the body 1, the plates 23, 23 are inserted in through slots 26 in the raised portion 21 of the covering element 7, and in a lowered portion 27 of the base element 6, where the slot 26 is not shown in Figure 2.

The closure lid 8 serves to protect the knobs 18, 18 as well as the respective
15 caps 19, when the end device according to the invention is closed, in the case, for example, the end device is removed by the external treatment equipment and there is no liquid flow.

As will be seen hereinafter, in this condition the closure lid 8 covers and protects from incidental operations also the knobs 11, 11 in their lowered
20 position. On the contrary, the closure lid 8 can not be inserted in the body 1 when the knobs 11, 11 are in their raised position, and this ensures the effective closed position of the pinch valves.

The base element 6 has a prismatic shape, although this form should not be construed as limiting. The interior of the base element 6, which is open at the
25 top, is hollow, and may be divided longitudinally into two compartments 28, 28 by a separation wall 30 if any.

The compartments 28, 28 house two substantially U-shaped rigid cradles 31, respectively, each cradle having a first wall 32 facing the catheters 2, 2 and a second wall 33 opposite to the first wall 32. In any rigid cradle 31, the first wall
30 32 is joined to the second wall 33 by means of a base (not denoted with a reference numeral) which acts as an anvil for the pinch valves. The two rigid

cradles 31 are removably anchored to the base element 6 through connecting means, for example, mortise and tenon, not shown in more detail in the figures.

With reference to Figure 2 as well as to Figure 3, which is a partially exploded longitudinal cross-section of an isometric view of the body 1 according to the invention, the end device according to the invention is shown to be axial-symmetric, and the features discussed for a part thereof identically apply also for the other part. The first wall 32 of the rigid cradle 31 is crossed by a through fitting 34, on which the catheter 2 is press fitted. The connection
5
10 between the through fitting 34 and the catheter 2 is ensured by a retaining means 35.

The second wall 33 of the rigid cradle 31 supports the connector 18 provided with a cap 19. Within the rigid cradle 31 there is an elastic tube 36 that connects the through fitting 34 with the corresponding connector 18. As
15 previously mentioned, the elastic tube 36 together with the flow control unit 10 forms a pinch valve in the end device according to the present invention.

Inside the closure lid 8 there is housed a prismatic shaped disposable absorbent material 37, which is impregnated with an antiseptic substance. The disposable absorbent material 37, preferably spongy, is inserted mainly on the
20 caps 19 thanks to two corresponding spaces 38 made in the absorbent material 37. The diameter of the space 38 will be slightly lower than that of the caps 19, so that the absorbent material 37 can adhere on them by protecting them with the action of the antiseptic substance.

In Figure 3 there are shown with greater clarity the parts already described in
25 the previous figures. In particular the cylindrical seat 9 and the flow control unit 10 with its knob 11 are shown in cross-section.

The cylindrical seat 9 is formed in the covering element 7 and is closed at its bottom. Centrally in the cylindrical seat 9 there is a hollow body 39 shaped, at least inside, as a rectangular cross-sectioned parallelepiped without bases,
30 which has its pair of major faces arranged in vertical planes orthogonal to the direction of the elastic tube 36. The outer shape of the hollow body 39, which

is not critical, is also parallelepiped in the shown embodiment.

The flow control unit 10 comprises a rectangular cross-section vertical pinching element 40, whose external dimensions correspond to those of the internal hollow body 39 in order to permit the vertical pinching element 40 to slide in the body 39, and a horizontal flat top 41 in a circular shape. The vertical pinching element 40 ends in its side opposite to the flat horizontal top 41 with a wedge-shaped lower end 42. The vertical pinching element 40 has a vertically elongated central cylindrical cavity 43, adapted to receive the pin 17 of the knob 11 hanging in the center towards the inside from its top 15 (Figure 3). The knob 11 engages the vertical pinch element 40 as an operation member for the movement of the latter.

A helical spring 44 is placed around the hollow body 39 in abutment between the bottom of the cylindrical seat 9 and the horizontal flat top 41 on its lower side.

As shown in more detail in Figure 5, which is an enlarged view of Figure 2 but represents only the base element 6 and the covering element 7, placed in a suitable position on the lateral surface of the cylindrical seat 9 is a pair of pins 45. On the side wall 14 of each knob 11 there is a pair of L-shaped grooves 46, each of them being intended to receive a pin 45 projecting from the lateral surface of the cylindrical seat 9. Each L-shaped groove 46 has a horizontal section 47 of length equal to a quarter of the circumference of the knob 11 and a vertical section 48 facing downwards. The pin 45 constitutes a fixed cam, and the knob 11 equipped with the L-shaped groove 46 represents the cam follower. The vertical section 48 of an L-shaped groove 46 is located in the side wall 14 of the knob 11 and is diametrically opposite to that of the other L-shaped groove 46. The vertical section 48 is so high that, when the pin 45 is located in the lower end of the vertical section 48 of the L-shaped groove 46 in which it is received, the horizontal flat top 41 of the vertical pinching element 40, and consequently the knob 11, are pushed upward by the helical spring 44. In this position of the pinch valve, the wedge-shaped lower end 42 of the vertical pinching element 40 does not deform the elastic tube 36. When the

knob 11 is manually pinched so that the pins 45, 45 are located in the respective opposite corners between the vertical section 48 and the horizontal section 47 of the L-shaped grooves 46, the wedge-shaped lower end 42 of the vertical pinching element 40 deforms the elastic tube 36 by closing the lumen thereof. The further rotation of the knob 11 so as to bring the pins 45, 45 in the horizontal section 47 of each the L-shaped groove 46 continues reliably the pinching of the elastic tube 36, while maintaining the interruption of the liquid flow internally. It was decided to use two pins 45, 45 and two L-shaped grooves 46, 46 for each knob 11 in order to retain always the same structure in its rotation and in its vertical translation.

Advantageously, with reference to the Figure 3, below the cylindrical seat 9 opened at the bottom in the hollow body 39, a septum 49 of elastically deformable plastic material best seen in the Figure 4 is placed, which shows an exploded side view of the device in the Figure 1. The septum 49 is interposed as a mechanical protection between the elastic tube 36 and the wedge-shaped lower end 42 of the vertical pinching element 40. Furthermore, the septum 49 provides a full insulation of the internal environment of the base element 6, in which the elastic tube 36 is located, from the outside environment, when the covering element 7 is closed and secured on the base element 6.

When the body 1 is assembled, each vertical pinching element 40 of the flow control unit 10 is inserted in the corresponding hollow body 39 of the respective cylindrical seat 9 in the covering element 7 of the device, with the wedge-shaped lower end 42 being arranged perpendicular to the longitudinal direction of the elastic tubes 36. The rectangular shape of the vertical pinching elements 40, 40 and of the hollow bodies 39, 39 prevents the rotation of the corresponding flow control units 10, 10 around the vertical axis.

Each knob 11 is positioned by inserting its pivot 17, hanging down from its top 15, in the cylindrical cavity 43 of the corresponding vertical pinching element 40, while each pin 45 of the cylindrical seat 9 is steadily received in the L-shaped grooves 46 provided in the side wall 14 of the knob 11. The constraint represented by the engagement of the pin 45 in the L-shaped groove 46 gives

the knob 11 freedom of rotating for a quarter of a circumference with respect to the cylindrical seat 9.

The relative positions of the diameter gripping ridge 16, of the L-shaped grooves 46 on the knob 11 and of the pins 45 on the cylindrical seat 9, are
5 chosen so that, in the closed position of the pinch valve, the diameter gripping ridge 16 of the knob 11 assumes a position orthogonal to the longitudinal direction of the elastic tubes 36.

With reference to Figure 5 the catheters 2, 2 being surrounded by the supporting tube sections 4, 4 are shown passing through the base element 6 in
10 its rear wall 50, and the connectors 18, 18 that are retained by the second wall 33 of the rigid cradle 31 frontally exit the base element 6 through semicircular openings 51 and 52, which are formed in the base member 6 and in the covering element 7, respectively. However, other constructive solutions, different from those shown, are possible.

15 In the assembly of the base element 6 of the body 1, each catheter 2 is inserted through the subcutaneous cuff 3 and the supporting tube section 4 to be press-fitted into the through fitting 34.

Within each rigid cradle 31, one end of the elastic tube 36 is connected to each through fitting 34, while its other end is connected to the corresponding
20 connector 18.

In order to complete the assembly of the body 1, the covering element 7 is fixed on the base element 6 by means of screws or other.

In order to set the pinch valve in the closed position, the knob 11 is lowered and rotated clockwise. After the knob 11 is lowered, the pins 45 will be located
25 in the corner between the vertical section 48 and the horizontal section 47 of each L-shaped groove 46 formed on the side wall 14 of the knob 11; by rotating ninety degrees clockwise the knob 11, each pin 45 moves, with respect to the knob 11, in the horizontal section 47 of its L-shaped groove 46. The downward displacement of the knob 11 is transmitted to the pinching
30 element 40 which, by its wedge-shaped lower end 42, throttles the elastic tube 36 for preventing the passage of liquid.

The septum 49 matching the cylindrical seat 9 simultaneously serves to mechanically protect the elastic tube 36 from an excessive pinching stress, and to completely insulate the catheters from the outside environment with a result of a relevant reduction of risks of infection for the patient.

5 The simultaneous downward movement of the knob 11 and of the respective flow control unit 10 causes the compression of the helical spring 44.

During a reverse operation, after rotating the knob 11 counterclockwise and positioning each pin 45 in the vertical section 48 of each L-shaped groove 46, the helical spring 44 pushes up the flow control unit 10 together with the knob
10 11. In this way the elastic tube 36 is released from the previous pinching, and the liquid flow can resume.

After using the end device, the connectors 18, 18 are closed by the caps 19, 19, and the disposable absorbent material 37 impregnated with the antiseptic substance is inserted on the caps 19, 19 thanks to the two corresponding
15 spaces 38. At the end the closure lid 8 is placed by inserting the plates 23, 23 thereof through the slots 26 formed in the raised portion 21 of the covering element 7 and, respectively, in the recessed portion 27 of the base element 6. When the full insertion of the plates 23, 23 in the body 1 is completed, the projecting portions 25 of the plates 23, 23 of the closure lid 8 snap into the
20 slot 22 formed in the raised portion 21 of the covering element 7 and, respectively, in the lowered portion 27 of the base element 6. If it is not possible to put the closure lid on the body 1, this means that the complete closure of one or both of the pinch valves did not occur and that the user or the nurse or other person in charge must be concerned to execute it. And this
25 is a further element of safety for the patient.

CLAIMS

1. An external end device for permanent catheters that is suitable for isolating a liquid flow from the environment, the external end device comprising a body (1) connectable on one side to two catheters (2, 2), and on the other side to either a closure lid (8) or a treatment equipment, two valves being provided in the body (1) for interrupting the liquid flow in the two catheters, characterised in that said valves are so-called pinch valves, the body (1) comprising a base element (6) housing two elastic tubes (36, 36) acting as pinch valve sleeves that are compressible until the closure of their lumen and are situated downstream of their respective catheters (2, 2) and upstream of the respective connectors (18, 18), and a covering element (7) containing two flow control units (10, 10) for said pinch valves in such a position to interact with the two elastic tubes (36 , 36) in order to achieve their closure by pinching them and their opening by releasing them.

2. The device according to claim 1, characterised in that the base element (6) is divided into two compartments (28, 28) accommodating respective rigid cradles (31, 31), each rigid cradle (31) being adapted to support on one side a through fitting (34) for connecting each elastic tube (36) to the respective catheter (2) and on the other side a respective connector (18) connected to the same elastic tube (36).

3. The device according to claim 1, characterised in that each flow control unit (10) includes a vertical pinching element (40) engaged with the cover element (7), for its movement with respect to the elastic tubes (36, 36), a horizontal flat top (41) and a driving member for the movement of the vertical pinching element (40).

4. The device according to claim 3, characterised in that each driving member includes a knob (11) having a side wall (14) and a top (15) and being housed in the cover element (7) in a cylindrical seat (9) thereof that is provided with a partially closed bottom, said knob (11), in contact with the horizontal flat top (41), being adapted to be displaced downward against a

counteracting spring (44) that is also housed in the cylindrical seat (9) and abutted against the horizontal flat top (41).

5 5. The device according to claim 4, characterised in that each vertical pinching element (40) is received in a prismatic guide in the form of a hollow body (39) open at both ends and contained within the cylindrical seat (9) so that the vertical pinching element (40) is adapted to pass through the bottom of the cylindrical seat (9).

10 6. The device according to claim 3, characterised in that a lower end (42) of each vertical pinching element (40) designed to come into contact with the corresponding elastic tube (36) is wedge-shaped.

15 7. The device according to claim 4, characterised in that applied to the covering element (7) underneath the cylindrical seats (9, 9), are two septa (49, 49) designed to interact with the vertical pinching elements (40, 40), said two septa (49, 49) being adapted to protect the elastic tubes (36, 36) and isolate the base element (6) from the environment.

20 8. The device according to claim 4, characterised in that each flow control unit (10) includes a couple of diametrically opposite radial projections in the cylindrical seat (9), in the form of pins (45) acting as cams, and of L-shaped grooves (46) made on the side wall (14) of the knob (11) so to receive respective pins (45), the knob (11) acting as a cam follower.

25 9. The device according to claim 1, characterised in that said closure lid (8) includes protruding plates (23, 23) provided with projections (25, 25) adapted to engage slots in the body (1), so as to embrace the body (1) to cover the pinch valves and prevent the operation thereof.

25

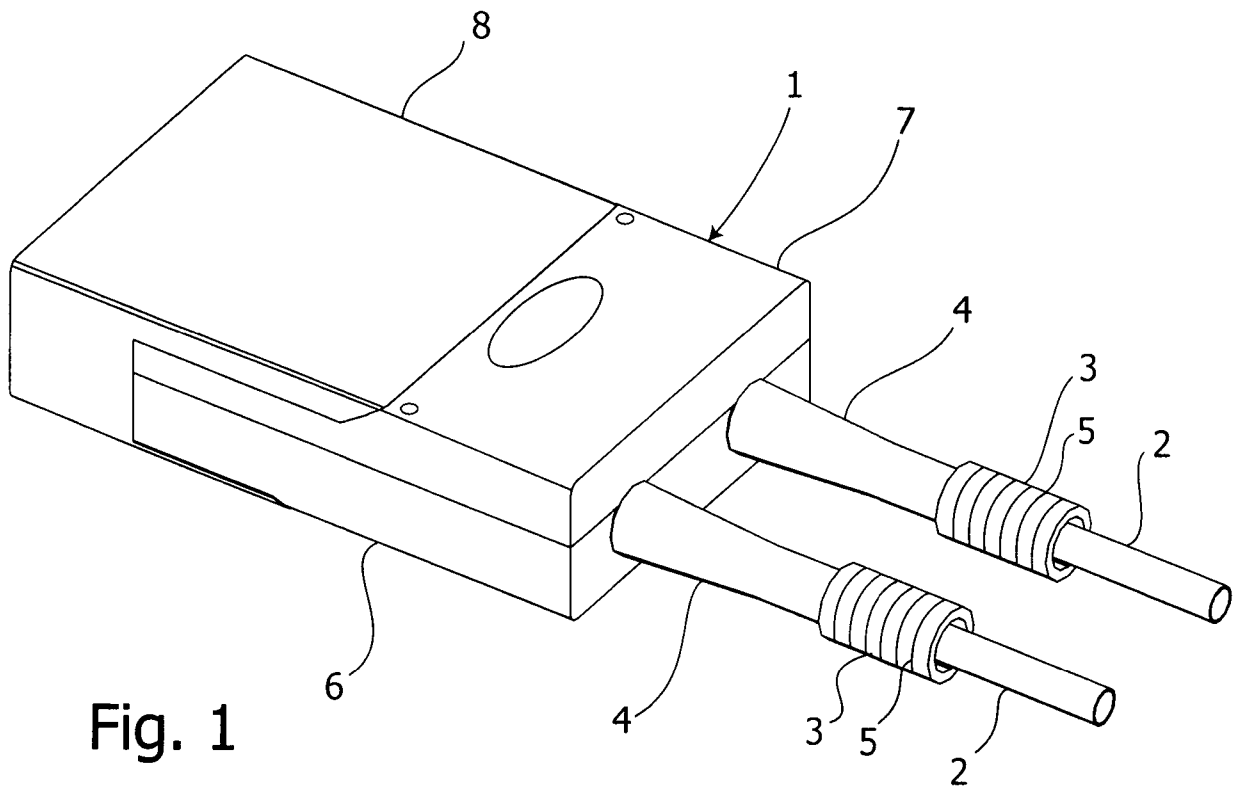

Fig. 1

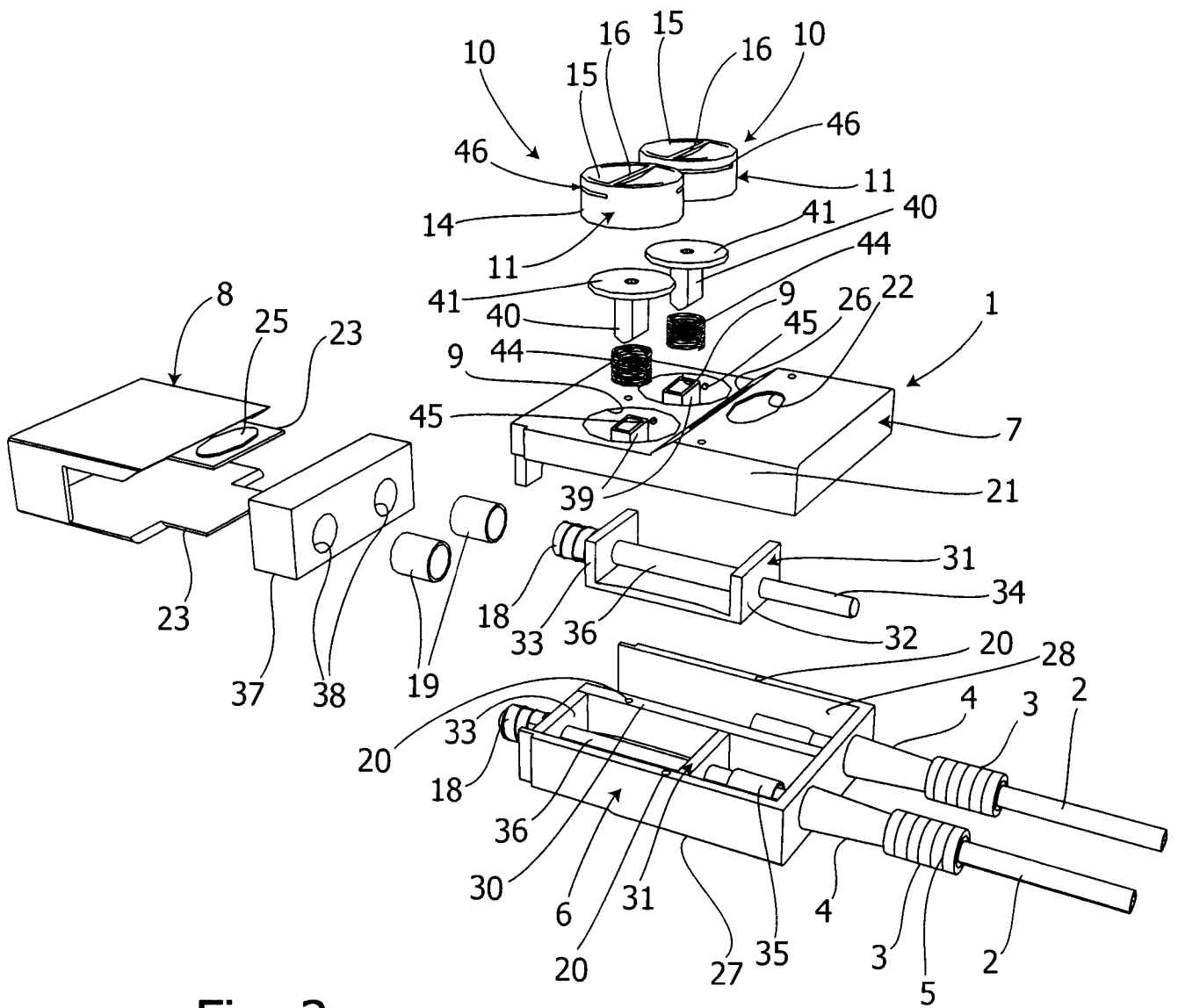

Fig. 2

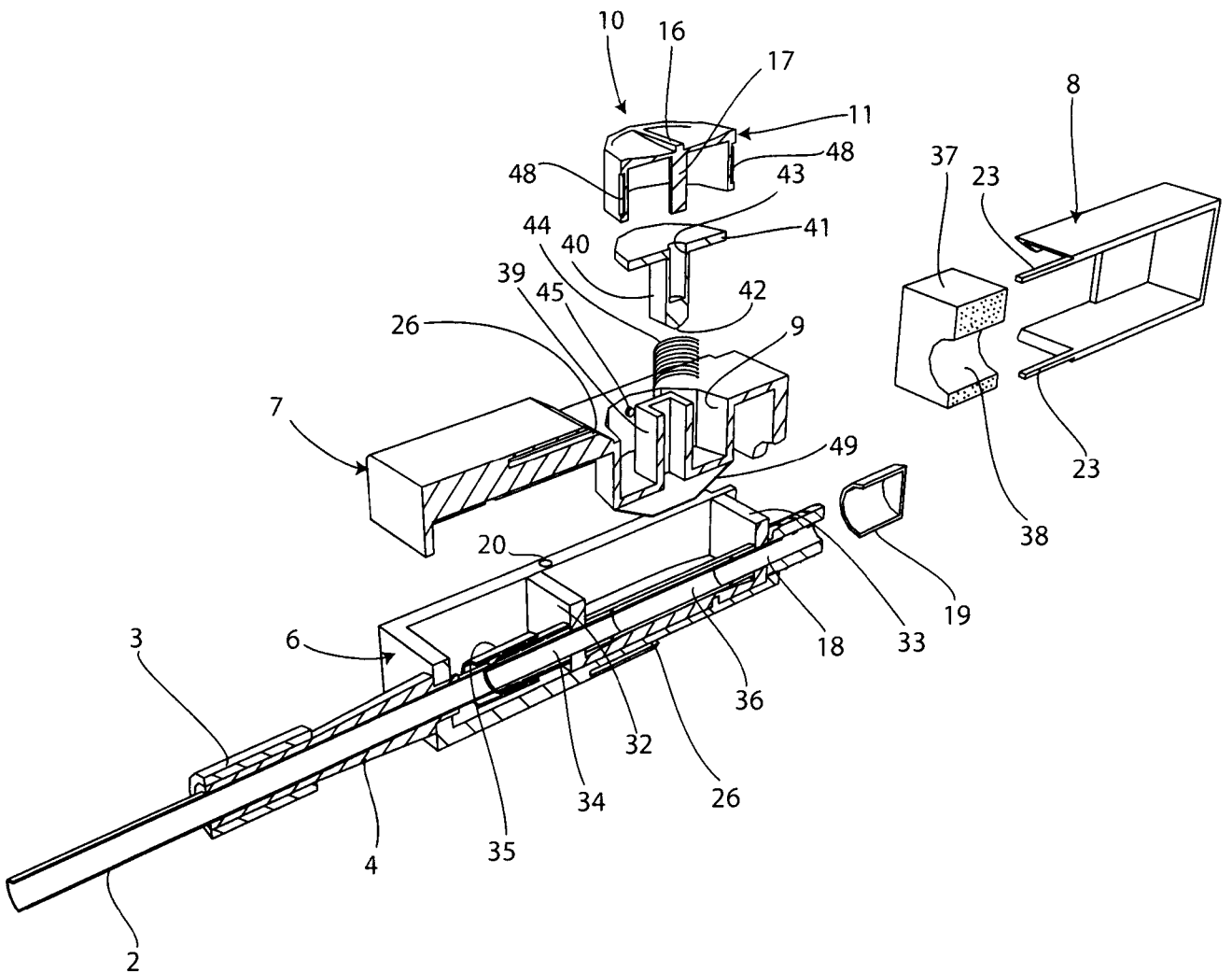

Fig. 3

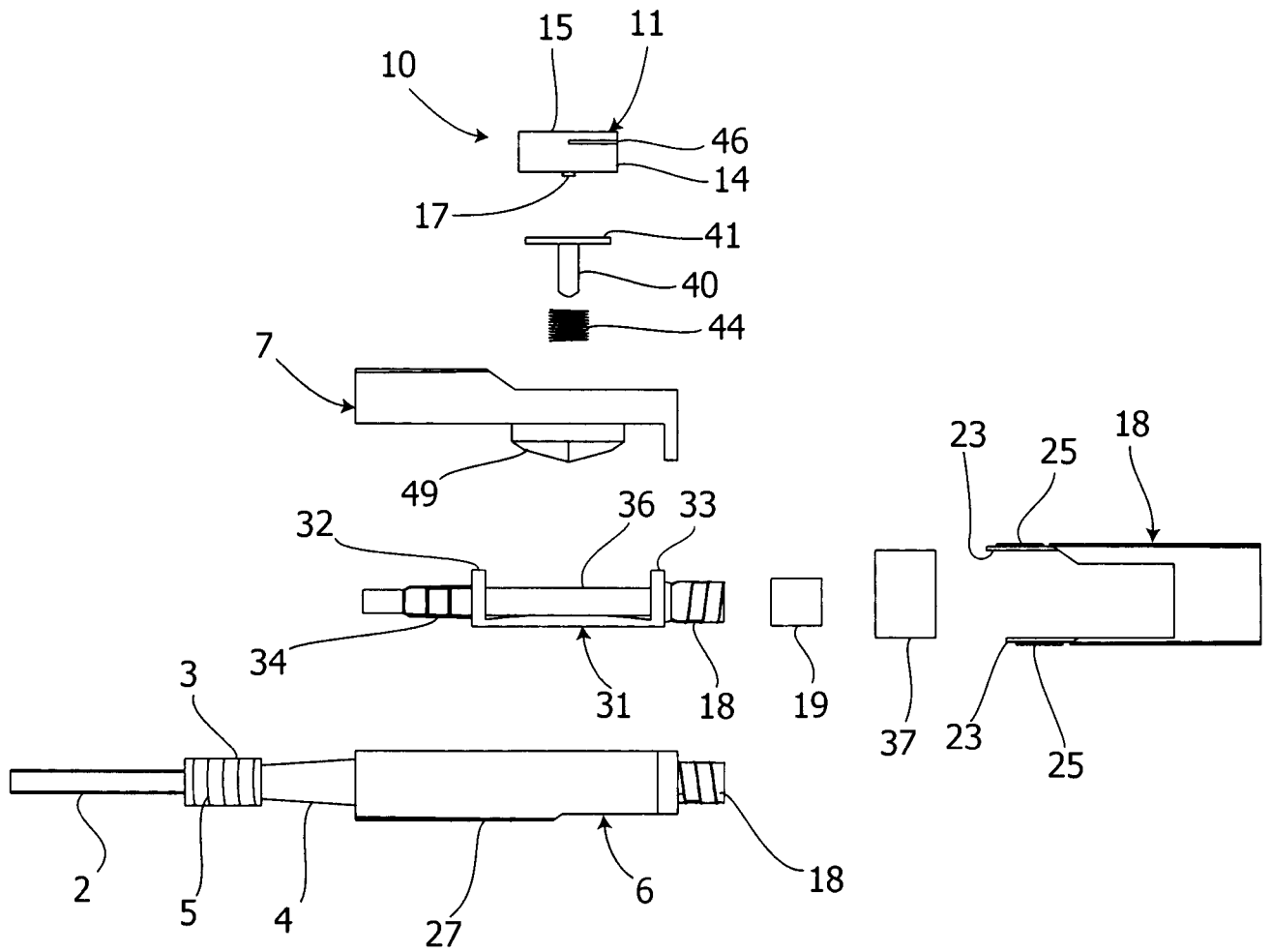

Fig. 4

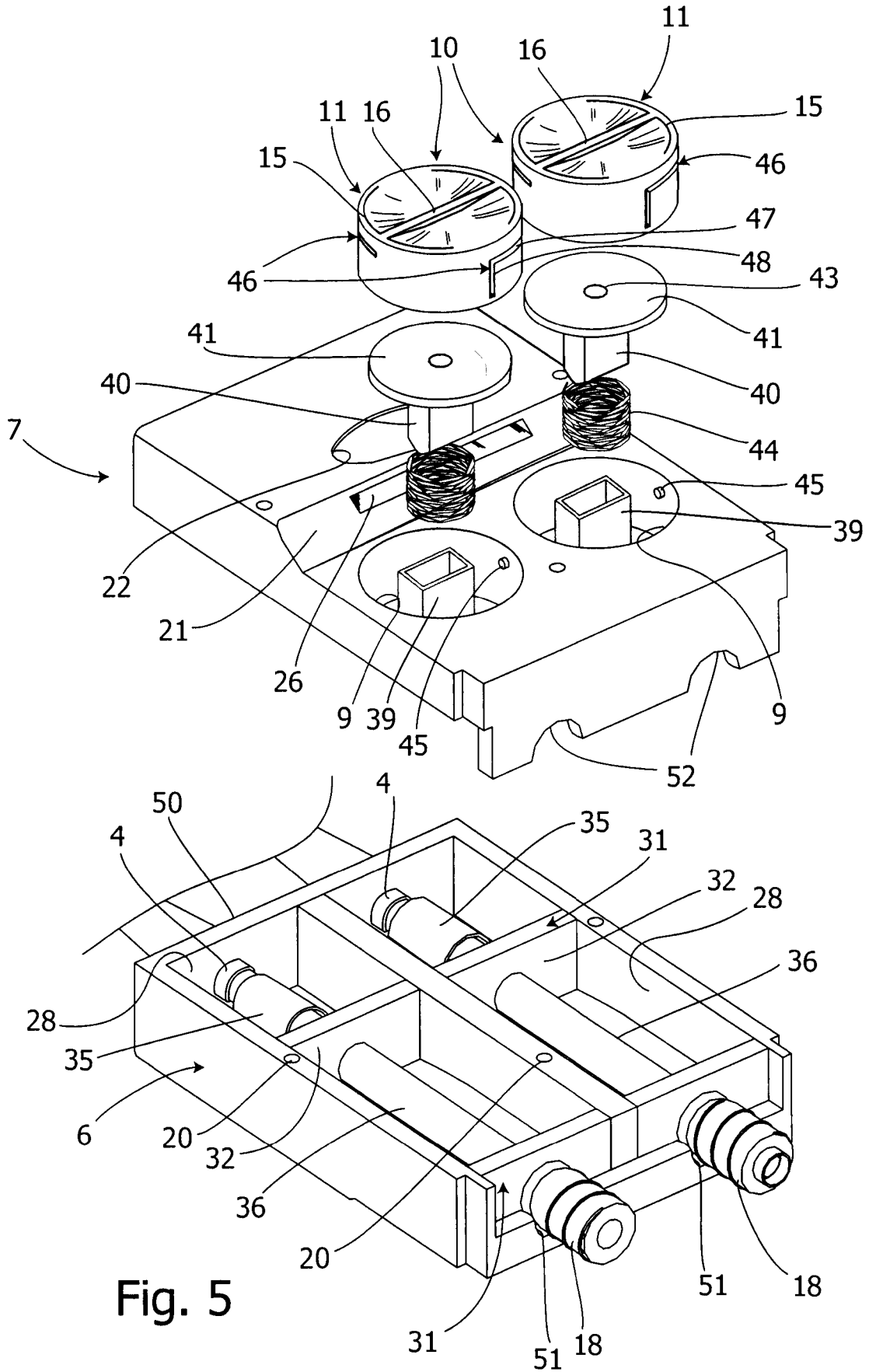

Fig. 5