

E. W. Slater,

2, Streets, Street, 1.

Excavator.

No. 99016.

Patented Jan. 18, 1870.

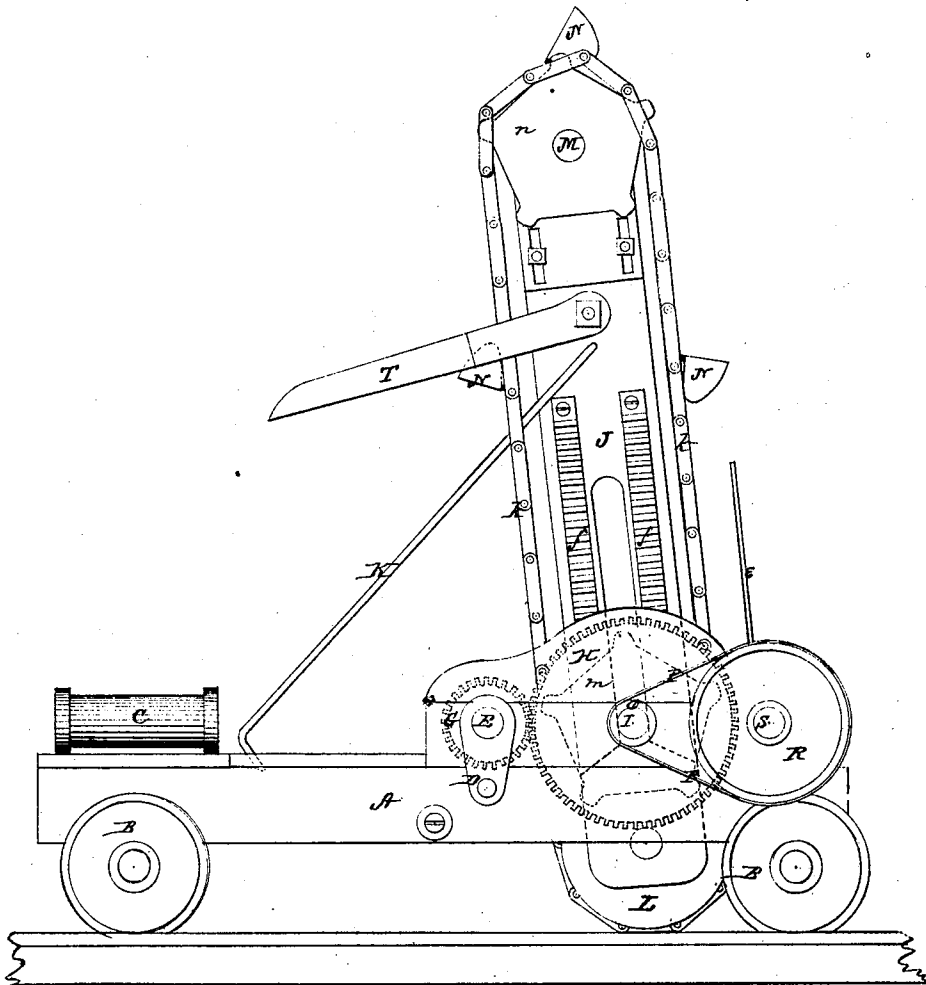

Witnesses
John A. Ellis,
Henry M. Miller

Inventor
E. W. Slater,
Per
S. H. Alexander
Atty.

F. W. Slater,

2, Sheets, Sheet 2,

Excavator.

No. 99016.

Patented Jan. 18, 1870.

Fig. 2.

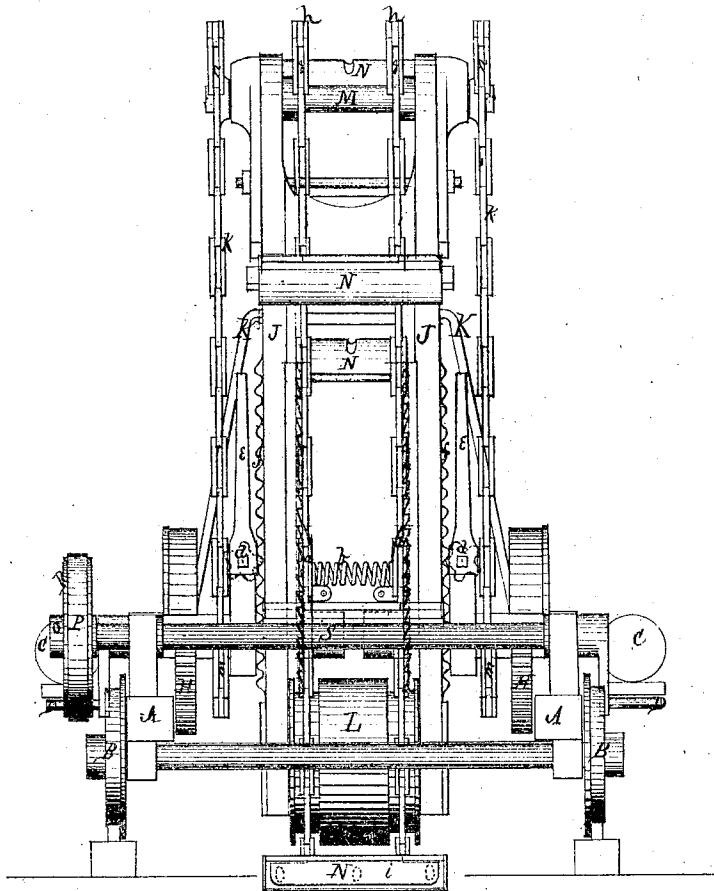

WITNESSES

John A. Ellis
Henry N. Miller

INVENTOR

F. W. Slater,
Per
F. W. Alexander,
Atty.

United States Patent Office.

FRANCIS W. SLATER, OF BAY CITY, MICHIGAN.

Letters Patent No. 99,016, dated January 18, 1870.

IMPROVED SEWER-EXCAVATOR.

The Schedule referred to in these Letters Patent and making part of the same.

To all whom it may concern:

Be it known that I, FRANCIS W. SLATER, of Bay City, in the county of Bay, and State of Michigan, have invented certain new and useful Improvements in Excavating-Machines; and I do hereby declare that the following is a full, clear, and exact description thereof, reference being had to the accompanying drawings, and to the letters of reference marked thereon, which form a part of this specification.

The nature of my invention consists in the construction and arrangement of a "sewer-excavator," which is self-feeding, and can be adjusted to any angle and to any depth desired.

In order to enable others skilled in the art to which my invention appertains, to make and use the same, I will now proceed to describe its construction and operation, referring to the annexed drawings, in which—

Figure 1 is a side elevation, and

Figure 2, a front view of my machine.

A represents a frame of suitable dimensions, mounted upon four truck-wheels B B.

Upon the rear end of the frame A, a boiler should be placed, with an engine, C, on each side, and said engines connecting with the cranks D D, upon the shaft E, which is mounted, in suitable bearings, across the frame A.

The shaft E is, on each end within the frame A, provided with a cog-wheel, G, which gears with larger cog-wheels H H, upon the bucket-shaft I, thus communicating the necessary rotary motion to the same.

Upon the bucket-shaft I are placed two ratchet-pawls *a a*, pressed outward by means of a spring, *b*, which pawls support two slotted beams J J, by means of ratchet-teeth placed on their inner sides, in which the pawls catch.

The shaft I passes through the slots in the beams J J, which are connected together at a suitable distance apart, and held at any angle desired, by means of the adjustable braces K K.

It might here be mentioned that the pawls *a a* are provided with collars, through which the shaft I passes, so that the pawls may be moved on the shaft, and the shaft revolve within the collars.

The beams J J are raised and lowered at will, by means of pinions *d d*, mounted upon shafts on each side, and the shafts turned by levers *e e*.

The pinions *d d* gear with rack-bars *f f*, placed upon the outside of the beams J J.

The pawls *a a* being pressed inward out of the ratchet-teeth, by any suitable means, by turning the

levers *e e* the frame J is readily raised or lowered at pleasure.

Between the lower ends of the beams J J is pivoted a roller, L, and at the upper ends of said beams is mounted a shaft, M, upon which are placed two toothed wheels *g g*.

Around these wheels and the roller L are passed endless chains *h h*, across which are secured a series of buckets N N. These buckets are formed almost in the shape of a V, with holes in the bottom to allow the water to pass out while the dirt is carried upward, and, as the buckets turn over the wheels *g g*, they are discharged from their contents, by means of a false bottom, *i*, hinged within each bucket, which will entirely free the bucket from all dirt.

The shaft M, with the chains *h h* and buckets N N, receive their motion from the bucket-shaft I, by means of endless chains *k k*, passed around toothed wheels *m m*, on the shaft I, and similar wheels *n n*, on the shaft M.

On one end of a bucket-shaft I is a pulley, O, which, by a belt, P, is connected with and communicates motion to a wheel, R, and shaft S, on which said wheel is mounted the shaft S, being placed in suitable journal-boxes across the front end of the frame A.

One end of a rope is to be attached to the shaft S, and the other end to some point ahead, whereby the machine is fed along the ground.

To the rear side of the beams J J is attached an inclined spout, T, into which the dirt falls as it is discharged from the buckets N N, and is thence carried off by an apron or other suitable means.

Having thus fully described my invention,

What I claim as new, and desire to secure by Letters Patent, is—

1. The frame A, engine C, cranks D D, shaft E, cog-wheels G H H, slotted beams J J, and bucket-shaft I, all constructed, combined, and arranged to operate in the manner set forth.

2. With the device mentioned above, the arrangement of pawls *a a*, spring *b*, slotted beams J J, adjustable braces K K, and levers *e e*, all constructed and operating as described.

In testimony that I claim the foregoing as my own, I affix my signature, in presence of two witnesses.

FRANCIS W. SLATER.

Witnesses:

H. G. ROBBINS,
GEORGE P. COBB.