

J. B. GHORMLEY.

Churn.

No. 50,349.

Patented Oct. 10, 1865.

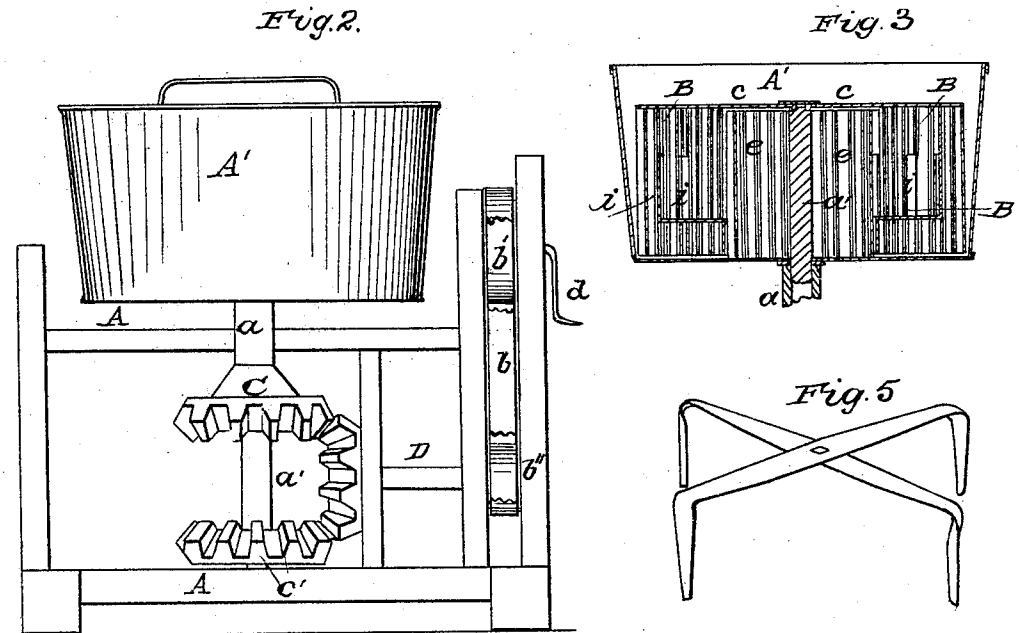
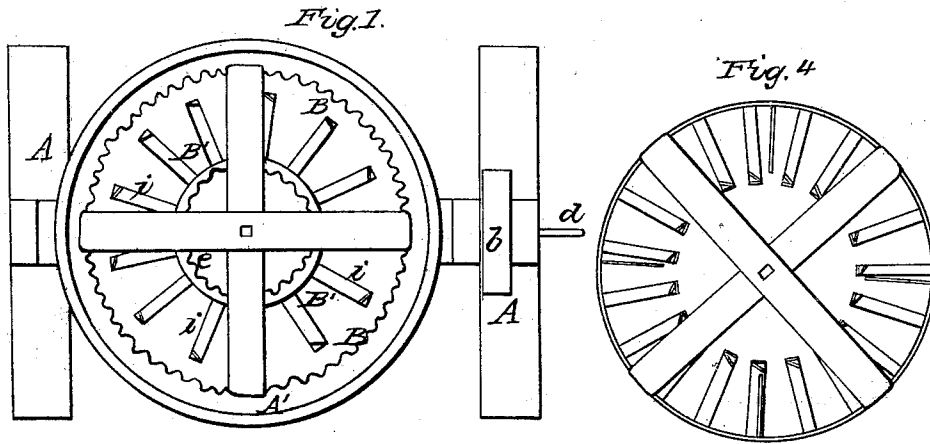

WITNESSES.
W. H. Sumdage
J. Holmes.

INVENTOR
John B. Ghormley.

UNITED STATES PATENT OFFICE.

JOHN B. GHORMLEY, OF BELLEFONTAINE, OHIO.

IMPROVEMENT IN CHURNS.

Specification forming part of Letters Patent No. 50,349, dated October 10, 1865.

To all whom it may concern:

Be it known that I, JOHN B. GHORMLEY, of Bellefontaine, in the county of Logan and State of Ohio, have invented certain new and useful Improvements in Churns; and I do hereby declare that the following is a full and complete description of the construction and operation of the same, reference being had to the accompanying drawings, making a part of this specification, in which—

Figure 1 is a top view. Fig. 2 is a side view. Fig. 3 is a vertical section. Figs. 4 and 5 will be referred to in the description.

Like letters of reference refer to like parts in the several views.

My improvement relates to a class of churns known as "double-action," as hereinafter described.

In the drawings, A represents the frame that supports the tub A' and beveled gearing.

b is a belt that turns on the pulleys b' b'', the churn being operated in the ordinary manner by a crank, d.

The pulley b'' is on one end of the driving shaft D, on the other end of which shaft is the beveled gear-wheel D', that works in the beveled gear-wheels C C'.

To the gear-wheel C is attached a hollow shaft, a, to which the tub is fastened. The shaft a' passes through and turns in the hollow a and up through the tub, as seen in Fig. 3, to which the dashers are attached, and by which means they are operated. The wheel C turns the tub in one direction while the

wheel C' is turning the dashers in the opposite direction, thus greatly agitating the cream.

B is a corrugated dasher, across which dasher, at right angles to each other, are arms e, that are connected to the shaft a' and hold the dasher in place when it is in motion.

B' is a dasher that forms a rim, which rim fits round a corrugated center piece, e, fastened to the tub. From this rim arms i extend out and then turn upward, being twisted so as to present more surface for the agitation of the cream.

Different forms of dashers may be used, if desired. One form is shown in Fig. 3, being a top view of the dasher, and in Fig. 5 the perspective view of another form.

The tub is made to turn, but if desired it may be stationary and only the dashers turn. In this case the beveled gear-wheel C would not be necessary.

Substantially the same devices can be applied to washing clothes, and either of the forms of dashers used.

What I claim as my improvement, and desire to secure by Letters Patent, is—

The arrangement of the circular corrugated dasher B and dasher B' or their equivalents, in combination with the corrugated center e, tub A', and hollow shaft a, when operating in the manner and for the purpose set forth.

JOHN B. GHORMLEY.

Witnesses:

PHILANDER JONES,
ISAAC ALLMAN.