

May 9, 1933.

A. G. GAGE

1,907,948

SINGLE VALVE WELL PUMP

Original Filed July 17, 1929

2 Sheets-Sheet 1

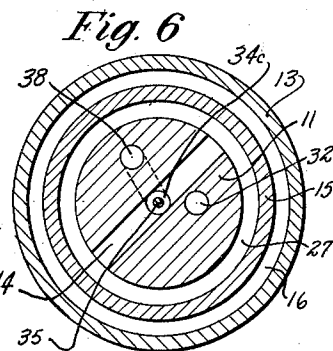
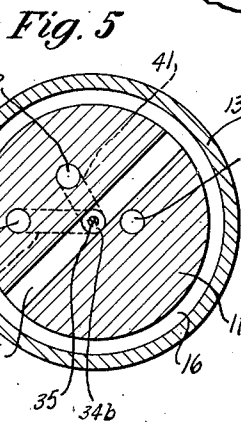
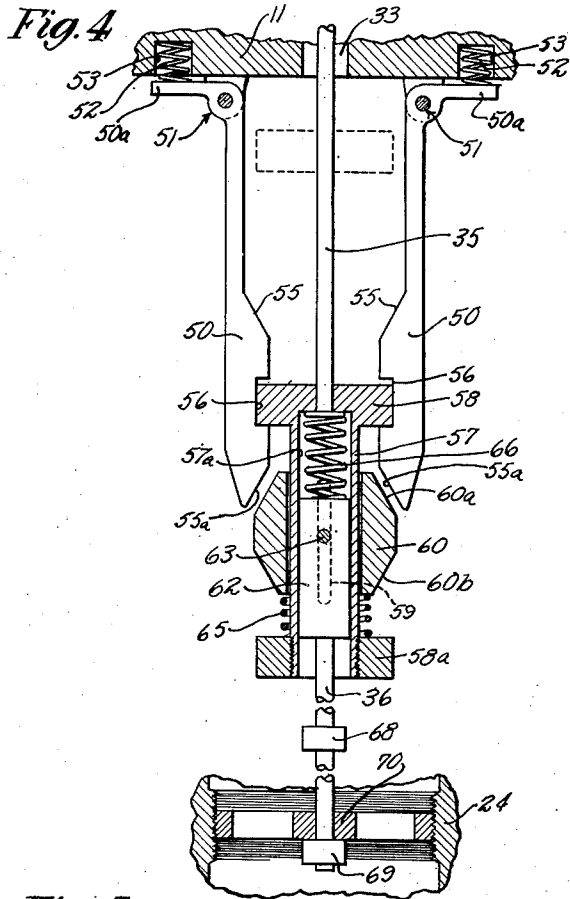
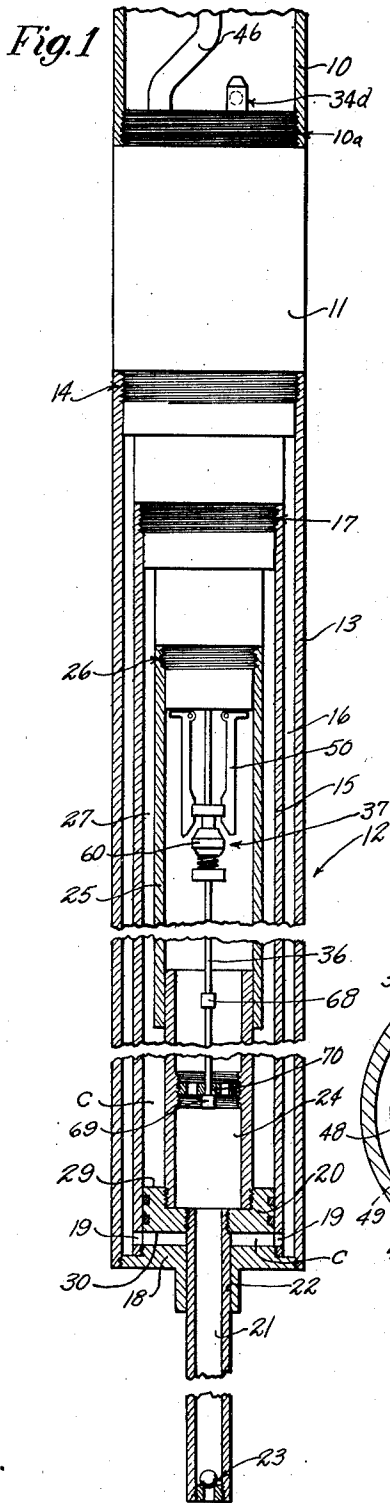

Inventor
Arthur G. Gage.

James T. Buckle
Attorney.

May 9, 1933.

A. G. GAGE

1,907,948

SINGLE VALVE WELL PUMP

Original Filed July 17, 1929 2 Sheets-Sheet 2

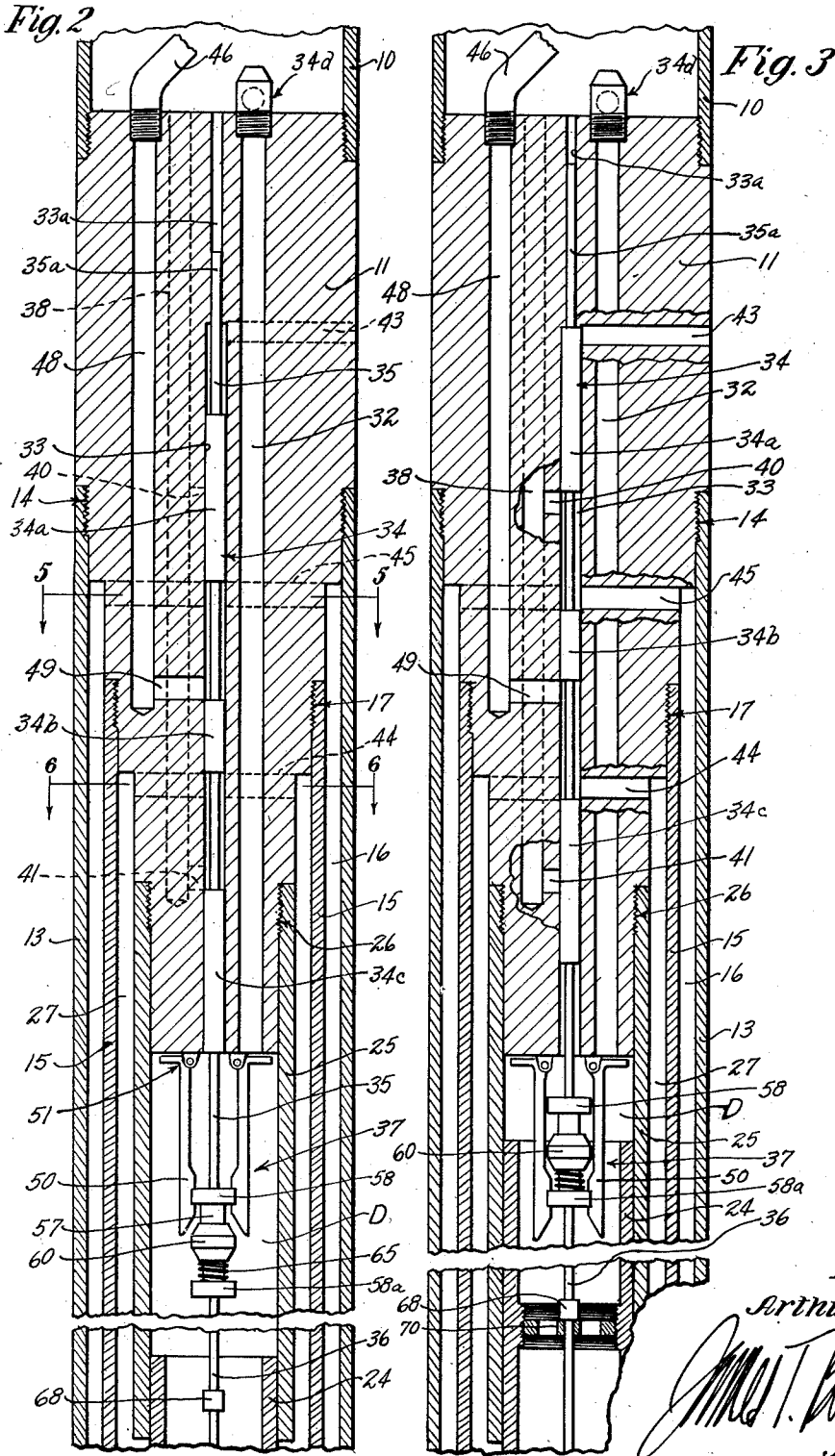

Inventor
Arthur G. Gage.

James T. Buckle
Attorney.

UNITED STATES PATENT OFFICE

ARTHUR G. GAGE, OF LOS ANGELES, CALIFORNIA

SINGLE VALVE WELL PUMP

Application filed July 17, 1929, Serial No. 378,921. Renewed October 7, 1932.

This invention has to do generally with deep well pumps and relates more particularly to fluid actuated pumps of the character described in my copending patent applications on oil well pump, Ser. No. 109,098, filed May 14, 1926 and on valve actuating device, Ser. No. 302,737, filed August 29, 1928.

The present pump and those disclosed in the referred applications may be described generally as being of the type adapted to be carried on the lower end of a well pipe and comprising a pumping piston actuated by high pressure fluid, for instance a preferably clean oil delivered from the ground level to the pump piston chamber through a conduit in the well pipe, and through fluid passages in the pump valve head. The pumped liquid from the well is discharged upward through the valve head by the piston and is exhausted into the well pipe, and thence conducted to the ground surface. Although provision may readily be made whereby the delivery of the actuating and exhaust fluids through the well pipe and conduit therein may be reversed, that is, whereby the high pressure fluid may be delivered to the pump through the well pipe proper and the pumped liquid exhaust through a conduit therein, the described arrangement is preferred.

Heretofore in pumps of this nature the delivery of the actuating fluid to the pump and the discharge of pumped well liquid have been controlled by a pair of piston valves in the pump valve head, one of the valves, the pilot valve, being actuated by connection with the pump piston and serving to direct the high pressure fluid against the other valve, termed the master valve, whereby the latter is caused to control the flow of the high pressure and exhaust fluids, and the operation of the pump piston. By virtue of the pilot valve being positively actuated by the piston to cause the master valve to be positively moved by fluid pressure to its proper positions and through its full length of travel, the pump is insured against stalling on dead center. In previous instances however, it has been necessary to employ the described combination of valves in order to

assure proper valve action to preclude any possibility of the pump becoming stalled.

By the present invention I have provided a valve head and valve structure in combination with a preferred form of valve locking device whereby the control of the pump actuating and exhaust fluids may be effected by a single valve. The valve may be positively actuated either due to differential fluid pressures and/or by direct connection with the pump piston, the locking device serving to hold the valve in adjusted position and being actuated by the piston to release the valve toward the ends of the piston strokes. I have shown in addition a preferred, though not limitative, form of piston and pump cylinder and barrel assembly generally similar to that described in the previously referred to copending application on oil well pump, which is particularly well suited for providing differential pressure areas on the piston ends, as will later be described, and for providing unrestricted fluid passages between the piston chamber and the valve head.

An additional feature embodied in the invention resides in the provision of a reciprocating valve which is capable of movement through both of its strokes by fluid pressure applied at its ends. Although, as will later be seen, I have shown in combination with a valve of this type, means for actuating the valve in addition to the application of fluid pressure, it will be understood that the last mentioned means may in some instances be unnecessary, but that generally it is desirable as an additional provision for assuring positive action of the valve. As stated however, the valve is capable of movement exclusively by fluid pressure. In order to lock the valve in position at the ends of its travel, a suitable locking device is embodied, and preferably a locking means of the type comprising the subject matter of my copending application on well pump, Ser. No. 378,923, filed on even date herewith, the operating characteristics of this device being such that the piston serves to actuate the locking means and to intermittently release the valve. And as mentioned, the locking device may preferably include

means in addition to the fluid pressure for actuating the valve. Although I have shown herein a form of pump embodying a single valve, it will be understood that insofar as
 5 the described action of the fluid pressure actuated valve in combination with the piston controlled locking device is concerned, this feature of the invention is not necessarily limited to a pump having a single valve, and
 10 that it may apply to the control of one of a number of valves.

The above features and additional details of the invention will be discussed more fully and to best advantage in the following
 15 detailed description, throughout which reference is had to the annexed drawings, in which:

Fig. 1 is a sectional view of the pump, the valve head being shown in elevation;

20 Fig. 2 is an enlarged medial section through the valve head showing the valve and the locking device in one position of adjustment, certain of the ports being varied from their true positions as shown in Fig. 5,
 25 for purposes of illustration;

Fig. 3 is generally similar to Fig. 2, and illustrates the valve and locking device in
 changed position;

30 Fig. 4 is a detailed and enlarged view of the valve locking device;

Fig. 5 is a section on line 5—5 of Fig. 2; and

Fig. 6 is a section on line 6—6 of Fig. 2.

As shown in the drawings, the pump is
 35 connected at its upper end, at 10a, with the lower end of the tubing 10, the latter being adapted to be lowered within the well casing (not shown) and the pump during operation being submerged beneath the standing
 40 level of the well liquid, in the usual manner. The pump comprises an upper valve head block 11, and the lower piston and cylinder assembly section generally indicated
 45 at 12. The latter section embodies an outer pipe 13 secured to the valve head at 14, and a piston cylinder 15 extending concentrically within the outer pipe and annularly spaced therefrom at 16, the piston cylinder
 50 being similarly mounted on the valve head at 17. A cap 18 is provided for the lower ends of the pipe 13 and the piston cylinder, the annular space 16 communicating with the interior of said cylinder by way of ports
 55 19. Within cylinder 15 is a vertically reciprocating piston 20 having a tubular extension 21 depending therefrom, the latter having a sliding fit within opening 22 in the bottom closure 18. Pipe 21 carries the usual
 foot valve 23 in its lower end.

60 A pipe sleeve 24 is carried on the upper end of the piston 20, the pipe having a sliding fit within a barrel 25 which is mounted at 26 on the lower end of the valve head and annularly spaced at 27 from the inside of
 65 the piston cylinder. By virtue of the de-

scribed piston construction and the concentric and spaced arrangement of the outer pipe 13, piston cylinder and barrel 25, provision is made for differential pressure area
 70 between the upper and lower faces 29 and 30 respectively, of the piston. It may be mentioned at this point that to move the piston on its upward or pumping stroke, high
 75 pressure fluid is introduced to chamber C below the piston by way of space 16 and ports 19, and to move the piston downward on its return stroke the high pressure actuating fluid is directed against the upper face
 29 of the piston by way of space 27.

Referring particularly to Figs. 2 and 3, bores 32 and 33 extend continuously through the valve head 11 and open into the pump displacement chamber D above the piston, and a check valve 34 being provided at the
 80 upper end of bore 32, and the upper end 33a of bore 33 being comparatively restricted as indicated. Within bore 33 is a vertically reciprocable valve 34 having a plurality of piston sections 34a, 34b and 34c.
 85 The valve stem or rod 35 extends at its upper end 35a within the reduced bore 33a, the lower end of the valve stem being connected with the valve actuating rod 36 by way of the locking device generally indicated at 37. Rod 36 is adapted to be
 90 intermittently engaged by the piston should the valve fail to be actuated by differential fluid pressures, as will hereinafter be explained.

An exhaust fluid passage 38 extends downward within the valve head and serves to
 100 establish communication between the interior of the well pipe 10 and valve bore 33 at vertically spaced points therein, by way of ports 40 and 41. The enlarged portion 33 of the valve bore is communicable
 105 with the well by way of the horizontal port 43 at its upper end. Intercommunication between the valve bore and the annular space 27 between piston cylinder 15 and the barrel 25 is established by way of ports
 110 44 at the upper end of space 27, the annular space 16 between the pump cylinder and outer pipe 13 likewise communicating with the valve bore through ports 45. The
 115 high pressure piston actuating fluid is delivered to the well pump from a pump (not shown) at the ground level, by way of a pipe or conduit 46 within the pipe 10. The high pressure fluid conduit opens into passage
 120 48 in the valve head, the actuating fluid being delivered from said passage to the valve bore by way of port 49.

As indicated in Fig. 2, when the valve 34
 125 is in its lower position, high pressure fluid is discharged into the outer annular space 16 by way of the valve bore between pistons 34a and 34b, and through ports 45. It may also be mentioned that in this position of the valve, liquid from the piston chamber C at
 130

pumping column pressure, or in other words the pressure within the well pipe 10, is discharged from space 27 into the exhaust fluid passage 38 and thence into pipe 10, by way of ports 44 and 41, and the valve bore between pistons 34b and 34c. When the valve is in its upper position shown in Fig. 3, the high pressure fluid is conducted to space 27 by way of the valve bore between pistons 34b and 34c, and ports 44, exhaust fluid from space 16 being discharged into passage 38 by way of ports 45, 40 and the valve bore between pistons 34a and 34b.

As previously mentioned, the valve is locked in its upper and lower positions of adjustment by means of the locking device generally indicated at 37, this device comprising the subject matter of the application on valve actuating device referred to hereinabove. As shown particularly in Fig. 4, the locking device embodies a pair of latch arms 50 pivotally mounted at 51 on the lower end of the valve head 11 and having toe portions 50a at their upper ends, the arms being urged to swing radially inward in an axial plane of the valve stem 35 by means of coil springs 52 placed in recesses 53 in the valve head and bearing against the toe portions 50a. The arms each are provided with oppositely inclined cam engaging faces 55 and 55a, notches 56 being formed midway between the inclined faces as shown. A sleeve 57 having a bore 57a and integral upper and lower detent flanges 58 and 58a, is mounted on the lower end of the valve stem. Slidably mounted on sleeve 57 is an annular spreader cam 60 having upwardly and downwardly pointing cam faces 60a and 60b respectively, a cylindrical block 62 within the sleeve bore 57a being fixed to the cam 60 by means of a pin 63 extending through the block and through longitudinal slots 59 in the sleeve. A spring 65 is placed around the sleeve and confined between the spreader cam and the lower flange 58a, and a second spring 56 is confined between the end of bore 57 and the upper end of block 62, the combined effect of these springs being to counterbalance one another when the device is in the position corresponding to that of Fig. 4. Rod 36, depending from the lower end of block 62, carries a pair of vertically spaced lugs 68 and 69, the distance between these lugs being less than the length of stroke of piston 20 by the length of travel of the valve 34. An abutment or spider 70 is carried within the interior of pipe 24 and is adapted to engage lugs 68 and 69 to actuate the valve locking device as will now be described.

Upon upward movement of the piston 20, the spider 70 is brought into engagement with lugs 68 thereby causing rod 36 and the cylindrical block 62 to move upward from the position shown in Fig. 4. The upper

conical cam face 60a is thus brought into engagement with the lower inclined faces 55a on the arms, the latter being caused to spread apart to release the detent flange 58 from engagement in notches 56. During the upward movement of block 62, spring 66 becomes compressed to the extent that immediately after flange 58 is released by the arms, the sleeve is thrown upward due to the action of the spring and the valve started on its upward travel. In the present case the valve is adapted to be actuated by fluid pressure during the remainder of its travel as will be later explained, but it may be mentioned that should the fluid pressure differential be insufficient to raise the valve, together with the locking device, to their upper positions of adjustment, shown in Fig. 3, the pump piston assembly by virtue of engagement of spider 70 with the lug 68, serves to raise the valve parts until the lower detent flange 58a becomes held in the notches 56 to lock the valve against further vertical movement. A reverse procedure is followed as the pump piston approaches the lower limit of its stroke and the spider is brought into engagement with lug 69. Thus it will be noted that the valve remains locked in its upper and lower positions, and is released by the locking device only when the pump piston approaches the limits of its strokes.

In describing the operation of the pump it may be assumed first that the piston is starting on its upward travel from the position of Fig. 1, the corresponding position of the valve being shown in Fig. 2. High pressure fluid delivered to passage 48 through the conduit 46 is delivered to the piston chamber C beneath the piston by way of port 49, the valve bore between pistons 34a, 34b, and ports 45, into the annular space 16 and thence through ports 19 in the bottom of the pump cylinder. As the piston is forced upward by the high pressure fluid, well liquid contained within the displacement chamber D, that is within pipes 21 and 24 and barrel 25, is forced upward through passage 32 in the valve head into the well pipe 10, through which the oil is conducted to the ground surface. The actuating fluid within the piston chamber C above the piston, delivered thereto during the previous down stroke of the piston, is discharged upward through the annular space 27 into the discharge passage 38 by way of ports 44 and 49, and the valve bore between pistons 34b and 34c.

It will be noted that during the up stroke of the piston, the pressure on the lower end of the valve 34 and on the upper end of the valve stem within the reduced bore 33a, is that pressure corresponding to the static head of oil in the pumping column, or in other words the column of liquid within

pipe 10. The upper annular end face of the valve piston 34a however is exposed to comparatively low well pressure due to the communication of bore 33 at its upper end with the well by way of port 43. Therefore a pressure differential on the upper and lower ends of the valve exists in proportion to the difference in areas between that of the lower end of the valve or the cross section area of the valve bore, and that of the reduced bore 33, the result being that by virtue of this differential pressure, the valve is forced upwardly from the position of Fig. 2 to that of Fig. 3, when released by the locking device as previously described.

Upon movement of the valve to its upper position shown in Fig. 3, the application of the actuating fluid and pumping column liquid pressures to the upper and lower ends of the pump piston 20 is reversed. Thus in this position, the high pressure fluid is delivered to the chamber C above the piston to force the latter down, by way of the valve bore between pistons 34b and 34c, ports 44 and the annular space 27, the liquid in chamber C beneath the piston being discharged into the exhaust passage 38 by way of the annular space 16, ports 45 and 40, and the valve bore between pistons 34a and 34b. And as in the previous instance, when the piston approaches the lower limit of its stroke and the locking device 37 is actuated through rod 36 to release the valve, the latter again is returned to its lower position by fluid pressure. During the down stroke of the piston it will be noted that the foot valve 23 is unseated to permit the well liquid to rise within the displacement chamber D, the pressure on the lower end of the valve end of the valve being that within the well, and which pressure may be considered but slightly above atmospheric. Thus during the downward movement of the piston, the pressure differential on the valve is that corresponding to column pressure on the upper end of the valve stem within bore 33a, and well pressure on the lower end of the valve, this differential being sufficient to return the valve to its lower position when released by the locking device.

I claim:

1. A fluid pressure actuated well pump carried on the lower end of a well pipe, embodying a pump chamber and a vertically movable piston in said chamber, high pressure and exhaust fluid passages communicable with said chamber, the high pressure fluid being adapted to move the piston through both of its strokes, a vertically movable valve within said pump for regulating the fluid flow through said passages whereby the ends of the piston each are alternately exposed to the actuating and ex-

haust fluid pressures said valve being operable in one direction by fluid pressure, and an operating member connected with said valve and depending within said pump chamber, said piston being adapted to intermittently engage said member to operate the valve.

2. A fluid pressure actuated well pump embodying a pump chamber and a vertically movable piston in said chamber, high pressure and exhaust fluid passages communicable with said chamber, the high pressure fluid being adapted to move the piston through both of its strokes, a single valve for regulating the fluid flow through said passages whereby the ends of the piston each are alternately exposed to the actuating and exhaust fluid pressures and means for locking said valve in adjusted position.

3. A fluid pressure actuated well pump embodying a pump chamber and a vertically movable piston in said chamber, high pressure and exhaust fluid passages communicable with said chamber, the high pressure fluid being adapted to move the piston through both of its strokes, a single valve for regulating the fluid flow through said passages whereby the ends of the piston each are alternately exposed to the actuating and exhaust fluid pressures and means actuated by the piston for releasably locking said valve in adjusted position.

4. A fluid pressure actuated pump adapted to be mounted at the lower end of a well pipe embodying, a valve head, a pump chamber below said valve head and containing a vertically movable tubular pump piston, high pressure and exhaust fluid passages within said pipe, means providing high pressure and exhaust fluid passages exclusive of the piston bore, communicable with the pump chamber and with the first mentioned passages through the valve head, and a valve within said valve head for regulating the fluid flow through said valve head whereby the ends of the piston each are alternately exposed to the actuating and exhaust fluid pressures, said valve being operable by fluid pressure and locking means for said valve.

5. A fluid pressure actuated pump adapted to be mounted at the lower end of a well pipe embodying, a valve head, a pump chamber below said valve head and containing a vertically movable tubular pump piston, high pressure and exhaust fluid passages within said pipe, means providing high pressure and exhaust fluid passages exclusive of the piston bore, communicable with the pump chamber and with the first mentioned passages through the valve head, and a single fluid pressure actuated valve member within said valve head for regulating the fluid flow through said valve head

whereby the ends of the piston each are alternately exposed to the actuating and exhaust fluid pressures and locking means for said valve.

6. A fluid pressure actuated pump adapted to be mounted at the lower end of a well pipe embodying, valve head, a pump chamber below said valve head and containing a vertically movable pump piston, high pressure and exhaust fluid passages within said pipe and communicable with the pump chamber through the valve head, a single fluid pressure actuated valve for regulating the fluid flow through said passages whereby the ends of the piston each are alternately exposed to the actuating and exhaust fluid pressures, and means for releasably locking said valve in adjusted position, said locking means being actuated by the piston.

7. A fluid pressure actuated pump adapted to be mounted at the lower end of a well pipe embodying, a valve head containing a vertical valve bore, a vertically movable piston valve in said bore, a pump chamber below said valve head and containing a vertically movable pump piston, high pressure, and exhaust fluid passages within said pipe and communicable with the pump chamber through the valve head, the high pressure fluid being adapted to move the piston through both of its strokes, and means for releasably locking said valve in adjusted position, said locking means being actuated by the piston.

8. A fluid pressure actuated pump adapted to be mounted at the lower end of a well pipe embodying, a valve head containing a vertical valve bore, a vertical movable and fluid pressure actuated piston valve in said bore, a pump chamber below said valve head and containing a vertically movable pump piston, high pressure, and exhaust fluid passages within said pipe and communicable with the pump chamber through the valve head, the high pressure fluid being adapted to move the piston through both of its strokes, and means for releasably locking said valve in adjusted position, said locking means being actuated by the piston.

9. A fluid pressure actuated pump adapted to be mounted at the lower end of a well pipe embodying, a valve head containing a vertical valve bore, a vertically movable piston valve in said bore, a pump chamber below said valve head and containing a vertically movable pump piston, high pressure and exhaust fluid passages within said pipe and communicable with the pump chamber through the valve head, and through said valve bore, the high pressure fluid being adapted to move the piston through both of its strokes, a latch mounted on said head and adapted to lock the valve in adjusted position, and means for actuating said latch at

the ends of the piston stroke to permit movement of the valve.

10. In a well pump, a cylinder and a fluid pressure operated pumping piston in said cylinder, reciprocating valve for controlling the delivery of fluid to said cylinder to operate the piston, said valve being movable through one of its strokes by fluid pressure, means for locking said valve at one end of its travel, and piston controlled means for releasing the valve from the locking means.

11. In a well pump, a cylinder and a fluid pressure operated pumping piston in said cylinder, a reciprocating valve for controlling the delivery of fluid to said cylinder to operate the piston, said valve being movable through both of its strokes by fluid pressure, means for locking said valve at the ends of its travel, and piston controlled means for releasing the valve from the locking means.

12. In a well pump, a cylinder and a fluid pressure operated pumping piston in said cylinder, a reciprocating valve for controlling the delivery of fluid to said cylinder to operate the piston, said valve being movable through one of its strokes by fluid pressure, means for locking said valve at one end of its travel, said locking means being adapted to be engaged by the piston to release the valve.

13. In a well pump, a cylinder and a fluid pressure operated pumping piston in said cylinder, a reciprocating valve for controlling the delivery of fluid to said cylinder to operate the piston, said valve having differential pressure areas on its opposite ends and being movable through both of its strokes by fluid pressures applied to its ends, means for locking said valve at the ends of its travel, and piston actuated means for releasing the valve from said locking means.

14. In a well pump, a cylinder and a fluid pressure operated pumping piston in said cylinder, a reciprocating valve for controlling the delivery of fluid to said cylinder to operate the piston, said valve being movable through one of its strokes by fluid pressure, and a valve locking device embodying, a pair of interconnected and relatively movable members, one joined to said valve and the other adapted to be actuated under control of the piston, yielding means resisting relative movement of the members, and means for locking the first mentioned member against movement with the other member, said locking means being releasable upon relative movement of the members.

15. In a well pump, a cylinder and a fluid pressure operated pumping piston in said cylinder, a reciprocating valve for controlling the delivery of fluid to said cylinder to operate the piston, said valve being movable through one of its strokes by fluid pressure,

means for locking said valve at one end of its travel, piston controlled means for releasing the valve from the locking means, and yielding means for moving the valve substantially throughout its travel.

16. In a well pump, a cylinder and a fluid pressure operated pumping piston in said cylinder, a reciprocating valve for controlling the delivery of fluid to said cylinder to operate the piston, said valve having differential pressure areas on its opposite ends and being movable through both of its strokes by fluid pressures applied to its ends, means for locking said valve at the ends of its travel, piston actuated means for releasing the valve for said locking means, and means actuated by the piston and acting to move the valve independent of the piston movement.

17. A fluid pressure actuated pump adapted to be mounted at the lower end of a well pipe embodying, a valve head containing a vertical valve bore, a vertically movable and fluid pressure actuated piston valve in said bore, a piston chamber below said valve head and containing a vertically movable pump piston, high pressure, and exhaust fluid passages within said pipe and communicable with the pump chamber through the valve head, said valve being actuated through one of its strokes by differential pressures acting on the valve.

18. A fluid pressure actuated pump adapted to be mounted at the lower end of a well pipe embodying a valve head containing a vertical valve bore, a vertically movable and fluid pressure actuated piston valve in said bore, a piston chamber below said valve head and containing a vertically movable pump piston, high pressure, and exhaust fluid passages within said pipe and communicable with the pump chamber through the valve head, said valve being actuated through both of its strokes by differential pressures acting on the valve.

19. A fluid pressure actuated pump adapted to be mounted at the lower end of a well pipe embodying, a valve head containing a vertical valve bore, a vertically movable and fluid pressure actuated piston valve in said bore, a piston chamber below said valve head and containing a vertically movable pump piston, a displacement chamber, high pressure and exhaust fluid passages within said pipe and communicable with the piston and displacement chambers respectively, through the valve head, the upper end of said valve having a comparatively small pressure area and being exposed to exhaust fluid pressure and the lower end of the valve having a comparatively large pressure area and being exposed to the pressure in said displacement chamber.

20. A fluid pressure actuated pump adapted to be mounted on the lower end of a well

pipe embodying, a valve head, a vertical valve bore extending continuously through the head, a vertically movable piston valve in said bore, a piston chamber below said valve head and containing a vertically movable pump piston, a displacement chamber, a high pressure fluid conduit within said pipe and communicable with the piston chamber through the valve head and through said valve bore, and an exhaust fluid passage within said head and communicable through the valve bore with the displacement chamber and the interior of said pipe, said piston valve being actuated by virtue of differential pressure areas exposed to the exhaust passage within said pipe and to said displacement chamber.

21. A fluid pressure actuated pump adapted to be mounted on the lower end of a well pipe embodying, a valve head, a vertical valve bore extending continuously through the head, a vertically movable piston valve in said bore, a piston chamber below said valve head and containing a vertically movable pump piston, a displacement chamber, a high pressure fluid conduit within said pipe and communicable with the piston chamber through the valve head and through said valve bore, an exhaust fluid passage within said head and communicable through the valve bore with the displacement chamber and the interior of said pipe, said piston valve being actuated by virtue of differential pressure areas exposed to the exhaust passage within said pipe and to said displacement chamber, and means for releasably locking said valve in adjusted position, said locking means being actuated by the piston.

22. A fluid pressure actuated pump adapted to be mounted on the lower end of a well pipe embodying, a valve head, an outer pipe mounted on said head and depending therefrom, a pump cylinder within said pipe and annularly spaced therefrom, a closure for the lower ends of the pipe and pump cylinder, a piston within said cylinder and a port in the lower end of the cylinder opening into said annular space, a barrel within said cylinder and annularly spaced therefrom, a tubular extension on the piston and adapted to slide vertically within said barrel, high pressure and exhaust fluid passages within said well pipe and communicable through the valve head with the annular spaces between said barrel, cylinder and outer pipe, and valve means in the head whereby the ends of the piston each are alternately exposed to the high pressure and exhaust fluid pressures.

In witness that I claim the foregoing I have hereunto subscribed my name this 10th day of June, 1929.

ARTHUR G. GAGE.