



(12) **EUROPEAN PATENT APPLICATION**

(43) Date of publication: **10.10.2001 Bulletin 2001/41**
 (21) Application number: **01303137.2**
 (22) Date of filing: **02.04.2001**
 (51) Int Cl.7: **F02M 63/00, F02M 63/02, F02M 61/20**

(84) Designated Contracting States:
AT BE CH CY DE DK ES FI FR GB GR IE IT LI LU MC NL PT SE TR
 Designated Extension States:
AL LT LV MK RO SI

(30) Priority: **07.04.2000 GB 0008598**

(71) Applicant: **Delphi Technologies, Inc. Troy, MI 48007 (US)**

(72) Inventors:
 • **Roper, Martin Burnell Newent, Gloucestershire GL18 1PZ (GB)**

• **Askew, James Martin Anderton Painswick, Stroud, Glos GL6 6XW (GB)**
 • **Milroy, William John Cheltenham, Gloucestershire GL51 5XJ (GB)**
 • **Fairs, Raymond Frederick Brockworth, Gloucestershire GL3 4UJ (GB)**
 • **Patel, Mahesh Cheltenham, Gloucestershire GL52 2AD (GB)**

(74) Representative: **Pople, Joanne Selina Marks & Clerk, Alpha Tower, Suffolk Street Queensway, Birmingham B1 1TT (GB)**

(54) **Fuel system**

(57) A fuel system comprising a fuel injector (13) having a delivery chamber (18) for fuel, a valve needle (16) which is engageable with a seating to control fuel delivery through an outlet opening (20) and a control valve arrangement (28) for controlling communication between a source (10) of pressurised fuel and the delivery chamber (28). The fuel system further comprises means (34, 64) for applying a force to a surface of the valve needle (16) so as to urge the valve needle against the seating should the control valve arrangement (28) fail.

The fuel system may be arranged such that, upon opening or closing movement of a control valve member (30) of the control valve arrangement (28), pressurised fuel is applied to a surface associated with the valve needle (16). This provides the advantage that opening or closing movement of the valve needle (16) is delayed, thereby enabling control and consistency of the injection of small amounts of fuel to be improved.

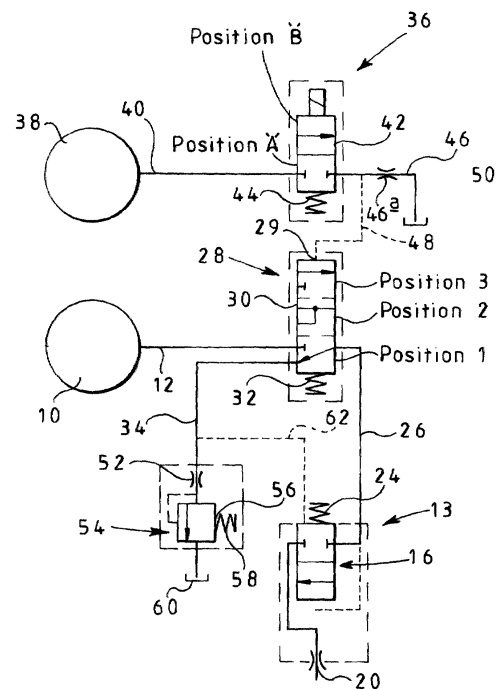

FIG 1

Description

[0001] This invention relates to a fuel system for use in supplying fuel under pressure to a combustion space of a compression ignition internal combustion engine. In particular, the invention relates to a fuel system of the common rail type.

[0002] In a known common rail system, a plurality of individually actuatable fuel injectors are connected to a common rail which is charged with fuel to a high pressure by a suitable high pressure fuel pump. Each injector includes a main control valve which controls communication between the common rail and a delivery chamber of the injector defined, in part, by surfaces of a needle of the injector. The valve needle surfaces are orientated such that the application of fuel under pressure to the delivery chamber applies a force to the needle urging the needle away from a seating to allow the delivery of fuel to one or more outlet openings. The main control valve is typically arranged such that when the delivery chamber is not in communication with the common rail, the delivery chamber communicates, through the control valve, with a low pressure drain reservoir.

[0003] Such an arrangement is disadvantageous in that should the main control valve become stuck in an open, or a partially open position, there is an undesirable delivery of fuel to the engine cylinder or other combustion space.

[0004] It is known to provide a "flow fuse" in the fuel flow path between the source of fuel at high pressure and the nozzle body of the fuel injector, the flow fuse acting to ensure that the supply of fuel to the nozzle body is terminated if the fuel flow becomes too high, for example if the control valve arrangement becomes stuck in an open position. However, flow fuses do not work well in situations where the flow rate is low but is continuous, for example if the control valve arrangement becomes stuck in a partially open position.

[0005] It is an object of the present invention to overcome the aforementioned problems.

[0006] According to a first aspect of the present invention there is provided a fuel system comprising a fuel injector having a delivery chamber for fuel and a valve needle engageable with a seating to control fuel delivery through an outlet opening, a control valve arrangement for controlling communication between a source of pressurised fuel and the delivery chamber, and means for applying a force to a surface of the valve needle to urge the valve needle against the seating should the control valve arrangement become stuck in a partially open position.

[0007] The invention provides the advantage that, should the control valve become stuck in a partially open position, for example due to contamination of the control valve seating by dirt or debris, the valve needle is urged against its seating to terminate fuel injection. Thus, undesirable injection of fuel is avoided.

[0008] The control valve may include a control valve

member which is resiliently biased towards a closed position in which communication between the source of pressurised fuel and the delivery chamber is broken. Conveniently, the control valve is moveable to an open position in which fuel is permitted to flow from the source to the delivery chamber so as to commence fuel injection.

[0009] The control valve member may have an intermediate position between the open and closed positions, the control valve arrangement being arranged such that, when the control valve member is in the intermediate position, pressurised fuel from the source applies a force to the valve needle which serves to urge the valve needle against its seating.

[0010] The control valve member may become stuck in its intermediate position if, for example, the valve seating for the control valve member becomes contaminated or damaged.

[0011] The fuel system may include a passage which communicates with the source of pressurised fuel when the control valve member is in the intermediate position. Conveniently, the fuel injector may include a chamber in communication with the passage, a surface associated with the valve needle being exposed to fuel pressure within the chamber.

[0012] This provides the advantage that, when it is desired to terminate injection and the control valve member is moved from its open position to its closed position, passing through the intermediate position, there is a temporary increase in fuel pressure in the chamber associated with the valve needle which applies a force to the valve needle, thereby serving to aid rapid closure of the valve needle. As closure of the valve needle is achieved relatively rapidly, fuel injection is terminated when fuel pressure within the delivery chamber is still relatively high, thus emissions are improved.

[0013] Additionally, when it is desired to commence injection, and the control valve member is moved from its closed position to its open position, passing through the intermediate position, the valve needle will remain seated for a short period of time, prior to injection, due to the increased fuel pressure within the chamber applying an increased force to the valve needle. The control valve member is therefore able to move to its fully open position prior to opening movement of the valve needle. This permits relatively small injections of fuel to be controlled with greater accuracy.

[0014] The passage may be provided with a pressure regulator arranged to hold fuel pressure in the delivery chamber at a predetermined value when the control valve member occupies the closed position.

[0015] The pressure regulator may take the form of a spring biased non-return valve located, in use, between the control valve arrangement and a low pressure drain reservoir.

[0016] Conveniently, movement of the control valve member may be controlled by controlling fluid pressure applied to a surface associated with the control valve

member.

[0017] The fuel system may further comprise a further valve arrangement for controlling fluid pressure applied to the surface associated with the control valve member. The further valve arrangement may include a further valve member which is biased towards a closed position by resilient bias means, movement of the valve member into an open position being controlled by means of an actuator, for example an electromagnetic actuator.

[0018] The fuel system may include a spring, or other resilient biasing means, for biasing the control valve member towards the closed position.

[0019] According to a second aspect of the present invention, there is provided a fuel system comprising a fuel injector having a delivery chamber for fuel, a valve needle engageable with a seating to control fuel delivery through an outlet opening, a control valve arrangement for controlling communication between a source of pressurised fuel and the delivery chamber, the control valve arrangement including a control valve member movable between open and closed positions, the system being arranged such that, upon opening or closing movement of the control valve member, pressurised fuel is applied to a surface associated with the valve needle to urge the valve needle against its seating.

[0020] Conveniently, the control valve arrangement includes a control valve member, said means for applying a force to a surface of the valve needle including a passage which communicates with the source of pressurised fuel upon closing movement of the control valve member, the passage delivering fuel to a chamber associated with the fuel injector so as to increase the force urging the valve needle towards its seating.

[0021] The invention will further be described, by way of example, with reference to the accompanying drawings in which:

Figure 1 is a schematic view of a fuel system in accordance with an embodiment of the invention, and

Figure 2 is a diagrammatic view of a fuel injector forming part of the fuel system in Figure 1.

[0022] Referring to Figures 1 and 2, a fuel system intended for use in supplying fuel to a compression ignition internal combustion engine comprises a common rail 10 arranged to be charged with fuel to a high pressure by an appropriate fuel pump (not shown). The common rail 10 is connected through passages 12 (only one of which is shown) to a plurality of fuel injectors 13 (only one of which is shown). As shown in Figure 2, each fuel injector 13 includes a nozzle body 14 provided with a blind bore within which a valve needle 16 is slidable. The needle 16 and the bore together define a delivery chamber 18 for fuel. The valve needle 16 is engageable with a seating to control communication between the delivery chamber 18 and a plurality of outlet openings 20 located downstream of the seating. The valve needle 16 in-

cludes thrust surfaces exposed to fuel pressure within the delivery chamber 18 and orientated such that the application of fuel under high pressure to the delivery chamber 18 applies a force to the valve needle 16, urging the valve needle 16 away from its seating.

[0023] The end of the valve needle 16 remote from the seating engages a spring abutment member 22 which, in turn, engages an end of a helical compression spring 24 which serves to urge the valve needle 16 towards its seating. The delivery chamber 18 communicates with a supply passage 26 for fuel, the supply of high pressure fuel from the common rail 10, through the passage 12 to the supply passage 26 being controlled by means of a control valve arrangement 28. The control valve arrangement 28 includes a control valve member 30 (illustrated diagrammatically in the drawing) which is movable against the action of a spring 32. The control valve member 30 is movable between a first, closed position (position 1, as shown in Figure 1) in which the supply passage 26 communicates through the control valve arrangement 28 with a second passage 34 and an open position (position 3) in which the common rail 10 communicates through the passage 12 and the control valve arrangement 28 with the supply passage 26 to supply fuel under high pressure to the delivery chamber 18. The control valve member is also movable through an intermediate position (position 2) between the closed position (position 1) and the open position (position 3). The control valve arrangement 28 is arranged such that, upon movement of the control valve member 30 between the open and closed positions, the control valve member 30 passes through the intermediate position in which fuel is briefly able to flow from the passage 12, through the control valve arrangement 28 and into the second passage 34, as will be described in further detail hereinafter.

[0024] Movement of the control valve member 30 is controlled by means of a further valve arrangement 36. The valve arrangement 36 is supplied with hydraulic oil from a source 38 through a third passage 40. The valve arrangement 36 includes a control valve member 42 which is biased by means of a spring 44 into a closed position (position A, as shown in Figure 1) in which hydraulic oil is unable to flow from the third passage 40, through the control valve arrangement 36 to a fourth passage 46 downstream of the valve arrangement 36. The control valve member 42 is movable to an open position (position B) in which the source 38 communicates through the third passage 40 and the valve arrangement 36 with the fourth passage 46. The fourth passage 46 communicates with an additional passage 48 in communication with a control valve chamber, referred to generally as 29, associated with the control valve arrangement 28 such that, when the control valve member 42 is in the open position, hydraulic oil is supplied to the control valve chamber 29 to apply a force to the control valve member 30 which serves to move the control valve member 30 to its open position, against the action of the

spring 32, so as to permit fuel within the passage 12 to flow to the supply passage 26. The fourth passage 46 includes a restriction 46a which serves to limit the rate of fuel flow through the fourth passage 46 to a low pressure oil reservoir 50. When the control valve member 42 is moved to the closed position, fuel within the control valve chamber 29 associated with the control valve arrangement 28 is able to flow through the additional passage 48, into the fourth passage 46 and to the low pressure drain. Movement of the valve member 42 may, for example, be controlled by means of an electromagnetic actuator (not shown).

[0025] The second passage 34 with which the supply passage 26 communicates when the control valve member 30 is in its closed position (position 1) includes a flow restrictor 52 which serves to limit the rate at which fuel is able to flow along the second passage 34 to a low pressure fuel reservoir 60. The second passage 34 also includes a pressure regulator 54 which takes the form of a spring biased non-return valve including a valve member 56 biased into engagement with the seating by a helical compression spring 58. It will be appreciated that, in an alternative embodiment of the invention, the pressure regulator 54 may be located elsewhere within the fuel system, for example it may form part of the fuel injector 13.

[0026] The second passage 34 communicates, through a further passage 62, with a chamber 23 associated with the valve needle, fuel delivered to the chamber 23 acting on a surface associated with the valve needle 16 so as to apply a force to the valve needle 16 which urges the valve needle 16 against its seating.

[0027] In use, in the position shown in Figure 1, the valve member 42 is biased into its closed position by means of the spring 44 such that oil from the source 38 is unable to flow through the third passage 40 and the valve arrangement 36 into the control valve chamber 29. The control valve member 30 therefore adopts its closed position in which high pressure fuel from the common rail 10 is unable to flow through the passage 12 and the control valve arrangement 28 to the supply passage 26. The valve needle 16 therefore remains seated against its seating due to the spring force and due to any residual fuel pressure in the chamber 23 acting on the surface of the valve needle 16. Thus, it will be appreciated that fuel injection through the outlet openings 20 does not occur.

[0028] In order to commence injection, the control valve member 42 is moved to its open position, against the force due to the spring 44, such that hydraulic oil in the third passage 40 is able to flow through the valve arrangement 36, into the fourth passage 46. Due to the presence of the restriction 46a in the fourth passage 46, it will be appreciated that oil is only able to escape to the low pressure reservoir 50 at a relatively low rate. Fuel flows from the fourth passage 46, through the additional passage 48 and into the control valve chamber 29 causing fuel pressure therein to increase. The control

valve member 30 is therefore moved to its open position to permit fuel within the passage 12 to flow into the supply passage 26. As a result, the delivery chamber 18 is pressurised and a point will be reached beyond which the fuel pressure within the delivery chamber 18 is sufficient to apply a force to the thrust surfaces of the valve needle 16 which is sufficient to lift the valve needle 16 away from its seating against the action of a spring 24. With the valve needle 16 lifted away from its seating, fuel is able to flow from the delivery chamber 18 through the outlet openings 20 and, as a result, injection of fuel takes place.

[0029] The control valve arrangement 28 is arranged such that, upon movement of the control valve member 30 from the closed position (position 1) to the open position (position 3), the control valve member 30 passes through the intermediate position (position 2) in which the passage 12 communicates, for a relatively short period of time, with the second passage 34. Thus, there is a temporary increase in fuel pressure in the passages 34, 62 and, hence, in the chamber 23 associated with the valve needle 16. The increase in fuel pressure in the chamber 23 serves to maintain the valve needle 16 in its seated position for a brief period of time, prior to injection, until fuel escapes, at a relatively low rate, through the flow restrictor 52 to the low pressure fuel reservoir 60. This provides the advantage that opening movement of the valve needle 16 is delayed for a short period, such that the valve member 42 of the valve arrangement 36 and the valve member 30 of the control valve arrangement 28 both travel towards their fully open positions prior to commencement of injection. This enables the control and consistency of the injection of relatively small amounts of fuel to be improved.

[0030] In order to terminate injection, the control valve member 42 is moved to its closed position in which hydraulic oil from the source 38 is unable to flow through the third passage 40 and the valve arrangement 36 into the passages 46, 48 and the chamber 29 associated with the control valve arrangement 28. Under such circumstances, fuel within the control valve chamber 29 is able to flow through the additional passage 48, into the fourth passage 46 and through the restriction 46a to the low pressure reservoir 50, thereby reducing the force applied to the control valve member 30 such that the control valve member 30 moves to its closed position under the action of the spring 32. When the control valve member 30 is in its closed position, communication between the passage 12 and the supply passage 26 is broken and the supply passage 26 communicates with the second passage 34. Thus, fuel is able to flow from the delivery chamber 18, through the supply passage 26 into the second passage 34 and towards the low pressure fuel reservoir 60, the rate of fuel flow to the low pressure reservoir 60 being limited by the flow restrictor 52. Such flow of fuel reduces pressure within the delivery chamber 18 and a point will be reached beyond which the force due to the spring 24, and due to fuel pressure with-

in the chamber 23 associated with the valve needle 16, is sufficient to urge the valve needle 16 against its seating to terminate the flow of fuel through the outlet openings 20.

[0031] After termination of injection, fuel continues to flow along the second passage 34, lowering the pressure within the delivery chamber 18 and the supply passage 26 until a point is reached beyond which fuel pressure within the delivery chamber 18 and the passages in communication therewith is insufficient to hold the valve member 56 of the pressure regulator 54 away from its seating against the action of the spring 58. Once this point is reached, the valve member 56 will move into engagement with its seating to terminate the flow of fuel towards the low pressure fuel reservoir 60. Thus, fuel pressure within the delivery chamber 18 and the supply passage 26 is held at a level insufficient to cause injection but greater than that of fuel within the low pressure reservoir 60.

[0032] As described previously, upon movement of the control valve member 30 from its open position to its closed position, the control valve member 30 passes through the intermediate position in which the passage 12 communicates, for a relatively short period of time, with the second passage 34. This gives rise to a relatively brief increase in fuel pressure in the passages 34, 62, and hence in the chamber 23 associated with the valve needle 16, such that an increased force is applied to the valve needle 16 for a short period of time. The brief increase in fuel pressure in the chamber 23 aids rapid closure of the valve needle 16 such that valve needle closure occurs when fuel pressure within the delivery chamber 18 is still relatively high, thereby improving emissions.

[0033] The arrangement also provides the advantage that, should operation of the control valve arrangement 28 fail such that the control valve member 30 becomes stuck in the intermediate, partially open position, the permanent communication between the second passage 34 and the chamber 23 associated with the valve needle 16 ensures the valve needle 16 will be held against its seating by means of pressurised fuel within the chamber 23. This avoids undesirable injection of fuel should operation of the control valve arrangement 28 fail. Operation of a control valve arrangement 28 may be caused to fail, for example, if the valve seating for the control valve member 30 becomes damaged or contaminated by dirt or debris. For the purpose of this specification, reference to failure of operation of the control valve arrangement 28 shall be taken to include any circumstances in which the control valve member 30 does not move to a fully closed position, when desired.

[0034] In addition to the provision of the further passage 62, a flow fuse may also be included in the fuel system between the common rail 10 and the injector 13. The provision of the flow fuse also ensures that the supply of fuel to the delivery chamber 18 is terminated if the total fuel quantity becomes too high, for example if the

control valve member 30 is stuck fully, or near fully, open. Although the provision of the flow fuse works well for fuel flows in excess of, typically, 10 to 20% of the normal flow rate, they do not work well for lower flow rates, typically less than 10% of the normal flow rate. The provision of the further passage 62 is necessary in order to overcome the problem of undesirable injection of fuel in circumstances in which the control valve member 30 becomes stuck in the partially open, intermediate position, as opposed to a fully open position.

[0035] It will be appreciated that the control valve arrangement 28 need not be controlled by means of a hydraulic valve arrangement but may be controlled by alternative means. It will also be appreciated that the valve arrangement 36 may take the form of a three-way valve controlling communication between the third passage 40 and the fourth passage 46 or between the third passage 40 and the additional passage 48.

[0036] In a further alternative embodiment of the invention, the fuel injector may comprise a piston member which is moveable with the valve needle 16, a surface of the piston member being exposed to fuel pressure within the chamber 23. Preferably, the piston member has a greater diameter than that of the valve needle.

Claims

1. A fuel system comprising a fuel injector (13) having a delivery chamber (18) for fuel, a valve needle (16) which is engageable with a seating to control fuel delivery through an outlet opening (20), a control valve arrangement (28) for controlling communication between a source (10) of pressurised fuel and the delivery chamber (18), and means (34, 62) for applying a force to a surface of the valve needle (16) to urge the valve needle (16) against the seating should the control valve arrangement (28) become stuck in a partially open position.
2. The fuel system as claimed in Claim 1, wherein the control valve arrangement (28) includes a control valve member (30) which is resiliently biased towards a closed position in which communication between the source (10) of pressurised fuel and the delivery chamber (18) is broken.
3. The fuel system as claimed in Claim 1 or Claim 2, wherein the control valve member (30) is moveable to an open position in which fuel is able to flow from the source (10) to the delivery chamber (18).
4. The fuel system as claimed in Claim 2 or 3, wherein the control valve member (30) has an intermediate position between the open and closed positions, the control valve arrangement (28) being arranged such that, when the control valve member (30) is in the intermediate position, pressurised fuel from the

source (10) applies a force to the valve needle (16) which serves to urge the valve needle (16) against its seating.

5. The fuel system as claimed in any of the preceding claims, comprising a passage (34) which communicates with the source (10) of pressurised fuel when the control valve member (30) is in an intermediate position between the open and closed positions. 5
6. The fuel system as claimed in Claim 5, wherein the fuel injector (13) includes a chamber in communication with the passage (34), a surface associated with the valve needle (16) being exposed to fuel pressure within the chamber. 10
7. The fuel system as claimed in Claim 5 or Claim 6, wherein the passage (34) is provided with a pressure regulator (54) arranged to hold fuel pressure in the delivery chamber (18) at a predetermined value when the control valve member (30) occupies the closed position. 20
8. The fuel system as claimed in Claim 7, wherein the pressure regulator (54) takes the form of a spring biased non-return valve located, in use, between the control valve arrangement (28) and a low pressure drain reservoir (60). 25
9. The fuel system as claimed in any of Claims 1 to 8, whereby movement of the control valve member (30) is controlled by controlling fluid pressure applied to a surface associated with the control valve member (30). 30
10. The fuel system as claimed in Claim 9, further comprising a further valve arrangement (36) for controlling fluid pressure applied to the surface associated with the control valve member (30). 35
11. The fuel system as claimed in Claim 10, wherein the further valve arrangement (36) includes a further valve member (42) which is biased towards a closed position by resilient bias means (44), movement of the further valve member (42) into an open position being controlled by means of an actuator. 40
12. The fuel system as claimed in any of the preceding claims, further comprising a flow fuse between the source of high pressure fuel and the injector. 45
13. A fuel system comprising a fuel injector (13) having a delivery chamber (18) for fuel, a valve needle (16) which is engageable with a seating to control fuel delivery through an outlet opening (20), a control valve arrangement (28) for controlling communication between a source (10) of pressurised fuel and the delivery chamber (18), the control valve ar-

angement (28) including a control valve member (30) movable between open and closed positions, the fuel system being arranged such that, upon opening or closing movement of the control valve member (30), pressurised fuel is applied to a surface associated with the valve needle (16).

14. The fuel system as claimed in Claim 13, wherein the control valve member (30) is resiliently biased towards the closed position, in which communication between the source (10) of pressurised fuel and the delivery chamber (18) is broken, the control valve member (30) being moveable to the open position to permit fuel to flow from the source (10) to the delivery chamber (18). 15
15. The fuel system as claimed in Claim 14, wherein the control valve member (30) has an intermediate position between the open and closed positions, the control valve arrangement (28) being arranged such that, when the control valve member (30) is in the intermediate position, pressurised fuel from the source (10) applies a force to the valve needle (16) which serves to urge the valve needle (16) against its seating. 20
16. The fuel system as claimed in any of Claims 13 to 15, comprising a passage (34) which communicates with the source (10) of pressurised fuel when the control valve member (30) is in an intermediate position between the open and closed positions. 25
17. The fuel system as claimed in Claim 16, wherein the fuel injector (13) includes a chamber in communication with the passage (34), a surface associated with the valve needle (16) being exposed to fuel pressure within the chamber. 30

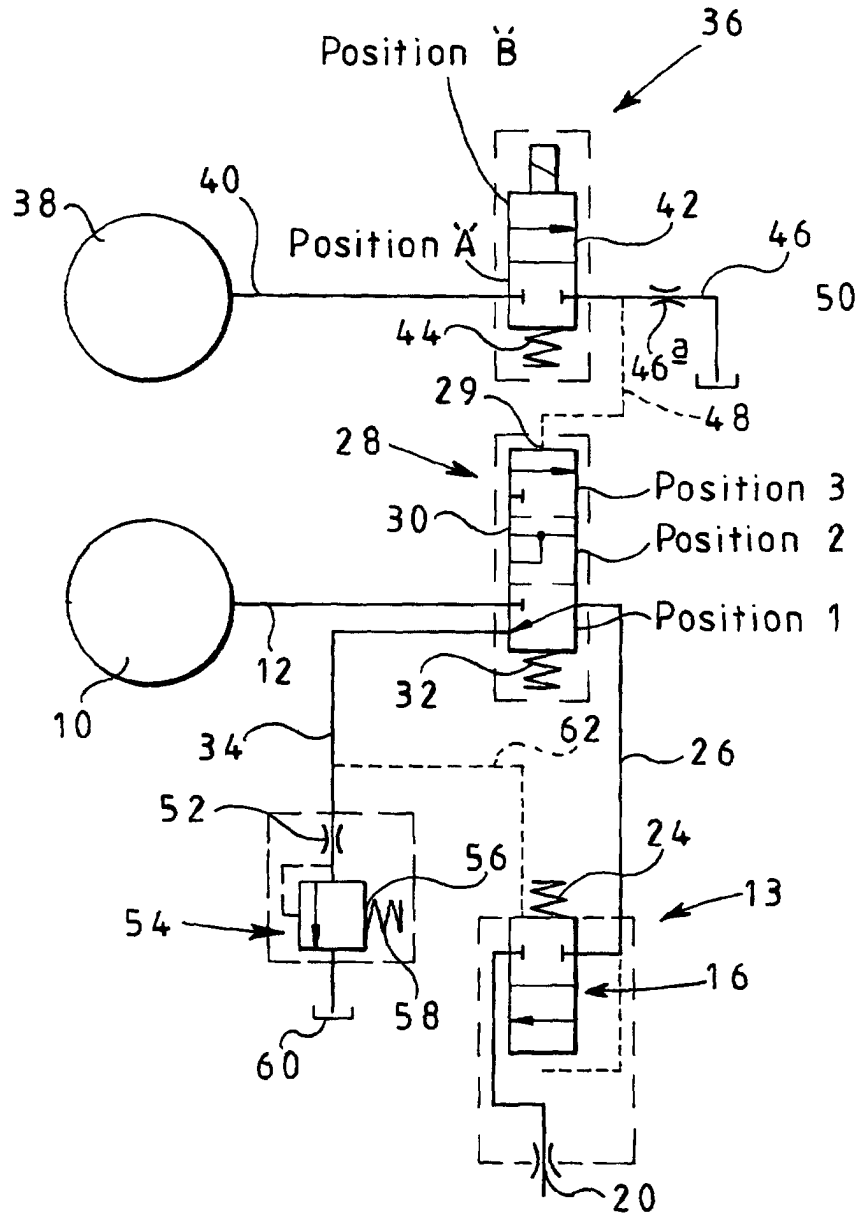

FIG 1

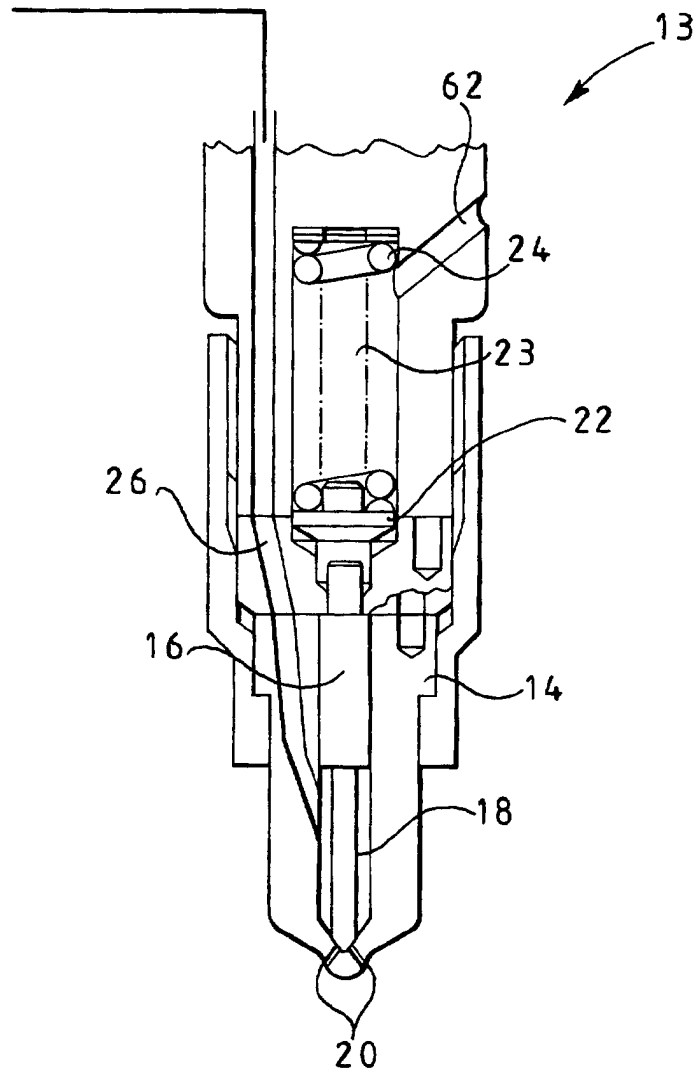

FIG 2



European Patent
Office

EUROPEAN SEARCH REPORT

Application Number
EP 01 30 3137

DOCUMENTS CONSIDERED TO BE RELEVANT			
Category	Citation of document with indication, where appropriate, of relevant passages	Relevant to claim	CLASSIFICATION OF THE APPLICATION (Int.Cl.7)
X	US 5 941 215 A (AUGUSTIN ULRICH) 24 August 1999 (1999-08-24)	1-6, 9-11, 13-17	F02M63/00 F02M63/02 F02M61/20
Y	* column 2, line 38 - column 3, line 63; figure 1 *	12	
X	US 5 988 533 A (AUGUSTIN ULRICH) 23 November 1999 (1999-11-23) * column 2, line 15 - column 3, line 35; figure 1 *	1-6, 13-17	
X,P	EP 1 036 931 A (DELPHI TECH INC) 20 September 2000 (2000-09-20) * paragraph '0010! - paragraph '0022!; figure 1 *	1,13	
X,P	WO 00 55490 A (MEISSONNIER GUILLAUME ;GUERRASSI NOUREDDINE (FR); BUCKLEY PAUL (GB) 21 September 2000 (2000-09-21) * abstract *	1,13	
Y	DE 195 48 610 A (BOSCH GMBH ROBERT) 26 June 1997 (1997-06-26) * abstract; figure 2 *	12	
			TECHNICAL FIELDS SEARCHED (Int.Cl.7)
			F02M
The present search report has been drawn up for all claims			
Place of search MUNICH		Date of completion of the search 18 July 2001	Examiner Kolland, U
CATEGORY OF CITED DOCUMENTS		T : theory or principle underlying the invention E : earlier patent document, but published on, or after the filing date D : document cited in the application L : document cited for other reasons	
X : particularly relevant if taken alone Y : particularly relevant if combined with another document of the same category A : technological background O : non-written disclosure P : intermediate document		& : member of the same patent family, corresponding document	

EPO FORM 1503 05/01 (P04001)

**ANNEX TO THE EUROPEAN SEARCH REPORT
ON EUROPEAN PATENT APPLICATION NO.**

EP 01 30 3137

This annex lists the patent family members relating to the patent documents cited in the above-mentioned European search report. The members are as contained in the European Patent Office EDP file on The European Patent Office is in no way liable for these particulars which are merely given for the purpose of information.

18-07-2001

Patent document cited in search report	Publication date	Patent family member(s)	Publication date
US 5941215 A	24-08-1999	DE 19706467 C FR 2759740 A GB 2322415 A,B IT RM980094 A	26-03-1998 21-08-1998 26-08-1998 18-08-1999
US 5988533 A	23-11-1999	DE 19717419 C EP 0874153 A	30-07-1998 28-10-1998
EP 1036931 A	20-09-2000	NONE	
WO 0055490 A	21-09-2000	NONE	
DE 19548610 A	26-06-1997	NONE	

EPC FORM P0455

For more details about this annex : see Official Journal of the European Patent Office, No. 12/82