

(No Model.)

C. RENNER, Jr.

ADJUSTABLE DEVICE FOR CARRIAGE CANOPIES.

No. 245,659.

Patented Aug. 16, 1881.

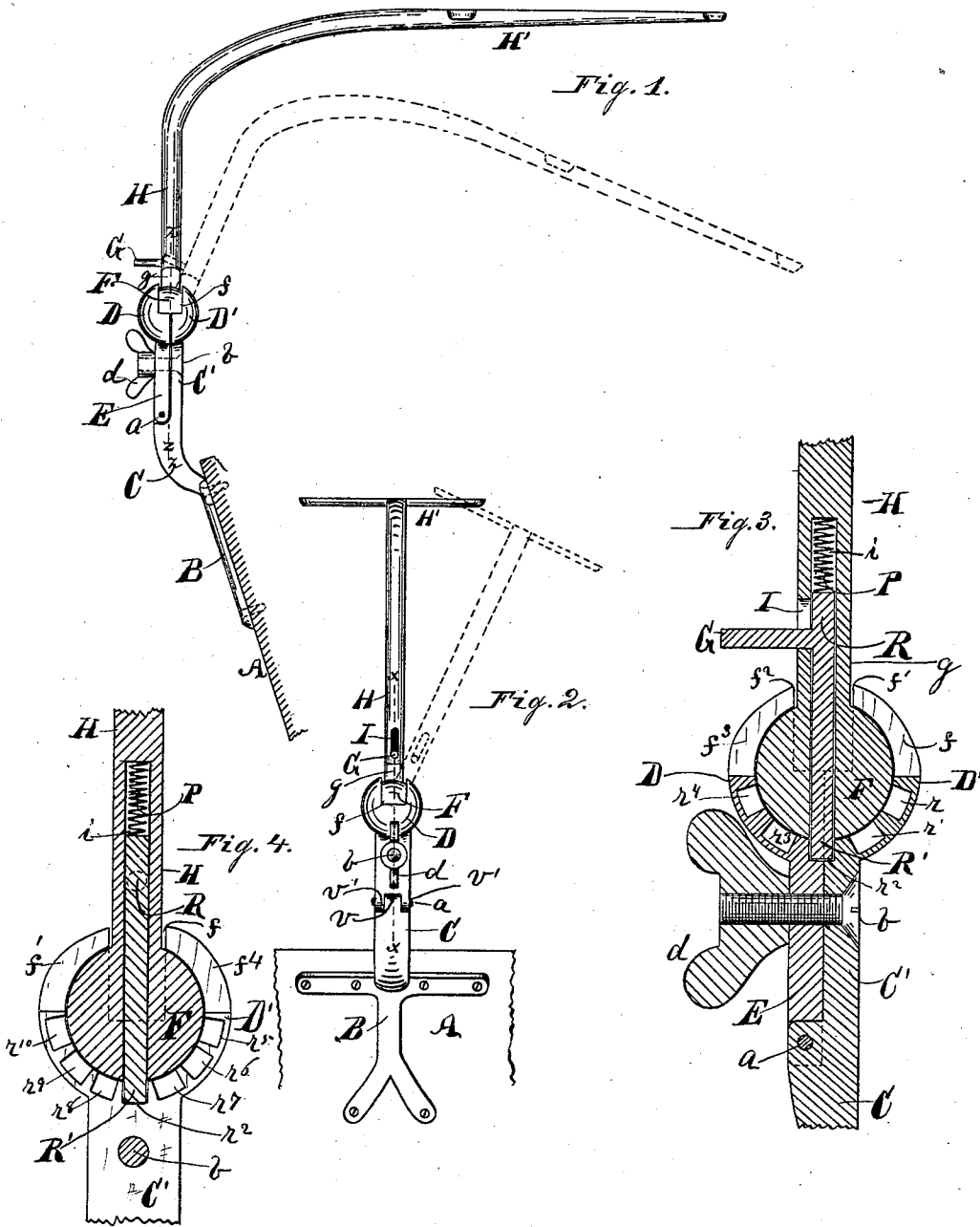

WITNESSES :

Geo. H. Rennell,
A. McCoy

INVENTOR :

Christ Renner, Jr.
Per E. Strink
his Attorney

UNITED STATES PATENT OFFICE.

CHRIST RENNER, JR., OF INDIANAPOLIS, INDIANA.

ADJUSTABLE DEVICE FOR CARRIAGE-CANOPIES.

SPECIFICATION forming part of Letters Patent No. 245,659, dated August 16, 1881.

Application filed May 24, 1881. (No model.)

To all whom it may concern:

Be it known that I, CHRIST RENNER, Jr., a citizen of the United States, residing at Indianapolis, in the county of Marion and State of Indiana, have invented a new and useful Adjustable Device for Holding Canopies or Shades on Children's Carriages, of which the following is a specification.

My invention relates to a device for supporting a canopy or shade on children's carriages, in which an adjustable forked ball-socket on one part of the device operates in conjunction with a ball on the square end of the upper arm; and the objects of my invention are, first, to provide a ball-socket in two halves hinged together, with quartering-notches at the top to hold the ball and the square end of the upper arm firmly in any desired position; second, to provide the inner surface of the two halves of the ball-socket with a series of pin-holes to receive a pin and hold the upper arm in any position it may be set at; third, to provide a means for clamping the two hinged halves of the ball-socket on the ball when the upper arm with its canopy or shade are placed in the desired position. These objects I accomplish by the device illustrated in the accompanying drawings, in which—

Figure 1 represents a side view of the entire device attached to the back of a child's carriage. Fig. 2 is a rear elevation of the same. Fig. 3 is a vertical longitudinal section taken at the line X X of Fig. 2; and Fig. 4 is a longitudinal vertical section taken at the line X Z of Fig. 1, with one-half of the ball-socket removed.

Similar letters refer to like parts throughout the several views.

A represents a portion of the back of a child's carriage. B is the bracket part of the lower arm, C, which is secured to the carriage-back. The arm C extends upward above the top of the carriage, and is provided on its rear side with a hinge-knuckle, *v*, to which the lower end of the arm E is pivoted at *a*. The upper end, C', of the arm C is provided with the half D' of the ball-socket. This half of the ball-socket D' is provided on its side with a full notch or recess, *f*, which extends from the top of the part D' to about midway of the socket-shell, and the edges of said socket which come in contact with the edges of the other half, D, are

provided with notches *f'*, one-half as wide as the notch *f*, which, together with the half-notches *f*² in the half D, make full notches to admit the square part *g* of the upper arm to be adjusted therein. The inner surface of the part D' is provided with pin-holes *r'* and one-half of the pin-hole *r*², the other half of the pin-hole *r*² being in the half D of the socket. The inner surface of the part D is also provided with a continuation of this row of pin-holes, as shown at *r*³ *r*⁴, Fig. 3.

In Fig. 4 a cross-row of pin-holes are shown. This row of holes *r*⁵ *r*⁶ *r*⁷ *r*⁸ *r*⁹ *r*¹⁰ are formed one-half in the part D and the other half in the part D' of the socket—that is, they are formed at the union of the two parts. The part D of the ball-socket has a downward-projecting arm, E, with hinge-knuckles *v'* *v'*, which are, as before described, pivoted to the knuckle *v* by the pin or bolt *a*. The two arms C' and E are each provided with a bolt-hole, in which the clamping-bolt *b* operates.

The ball F is provided with the upward-projecting arm H, and the lower end of said arm H is made square to fit in the recesses *f* *f'* *f*² *f*³, as desired. The arm H and ball F have a vertical hole, *i*, with a slotted opening, I, above the square part *g*. In this hole is first inserted the spring P, then the pin R, which may be round or square, and the handle G for raising or lowering the pin. The lower end, B', of the pin fits in any one of the holes *r* *r'* *r*² *r*³ *r*⁴ *r*⁵ *r*⁶ *r*⁷ *r*⁸ *r*⁹ *r*¹⁰, and is designed to prevent the arm H H' and its canopy or shade from working out of position, even though the binding-screw *b* and its nut *d* may become loose.

In setting up and operating my improved adjustable canopy or shade support the part B is made fast to the carriage, the bolt *b* is loosened, and the ball F inserted in the socket D D'. The arm H is then adjusted into the desired position, with its square part *g* in the center, between the ends of all the recesses *f* *f'* *f*² *f*³, the end R' of the pin resting in the hole *r*² in the center of the bottom of the socket. The binding-screw *b* *d* is then made fast, and the device is in the position shown in Figs. 1 and 2. If it is desired to tilt the arm H', to which the canopy (not shown) is attached, forward, then the binding-screw *b* *d* is loosened, the pin R' is raised, and the square part *g* of the arm

H is tilted forward into the full notch f of the part D' . The pin R' may be then inserted in the hole r^3 or r^4 , as desired, and the binding-screw b d made fast, thus holding the arm H H' 5 in the position shown in dotted lines in Fig. 1. If a side tilt is required for the canopy, the same operation is repeated; but the square part g of the arm H is tilted sidewise into the side recess, f' or f^3 , as desired. If tilted into the 10 recess f' and made fast, the arm H H' is inclined sidewise, as shown in dotted lines in Fig. 2.

Having thus fully described my invention and its mode of operation, what I claim as new, and 15 desire to secure by Letters Patent, is—

1. The arm C , with fastening-bracket B below, and provided with a hinge-knuckle, v , an upward-extending part, C' , and the half D' of the ball-socket, said socket being provided with 20 the full recess f and the two half recesses or notches f' f^3 , and further provided with the holes r r' and the half-holes r^5 r^6 r^7 r^2 r^8 r^9 r^{10} ,

(more or less,) combined with the half D of the ball-socket, having similar holes, r^3 r^4 , and half-holes to correspond with those in the part D' , 25 the arm E , with hinge a , the binding-screw b and nut d , substantially as shown and described.

2. In combination with the two halves D D' of the socket, constructed as described, the ball F , with arm H , having square part g , and 30 the pin R R' , substantially as specified.

3. The two halves D D' of the socket, having recess f to receive and hold at various angles the square end g of the arm H , combined with the ball F , the pin-hole r and pin R R' , substan- 35 tially as specified.

In testimony whereof I have signed my name to this specification in the presence of two subscribing witnesses.

CHRIST RENNER, JR.

Witnesses:

E. O. FRINK,
GEORGE H. RENNETT.