

(No Model.)

C. N. HAMMOND.
INSULATOR.

No. 524,850.

Patented Aug. 21, 1894.

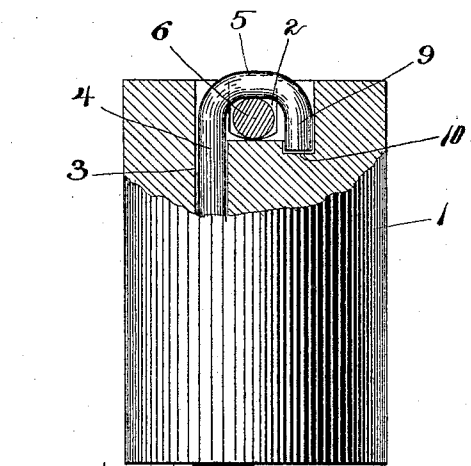

FIG. 1.

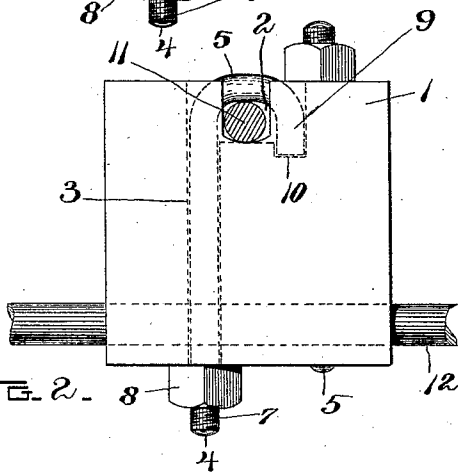

FIG. 2.

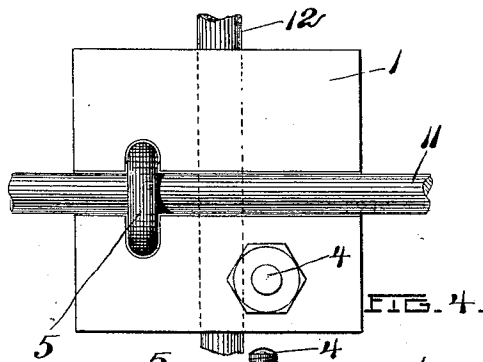

FIG. 4.

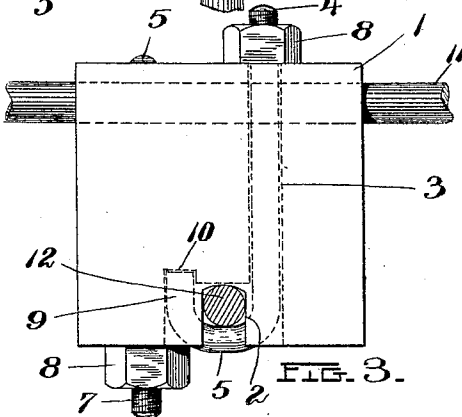

FIG. 3.

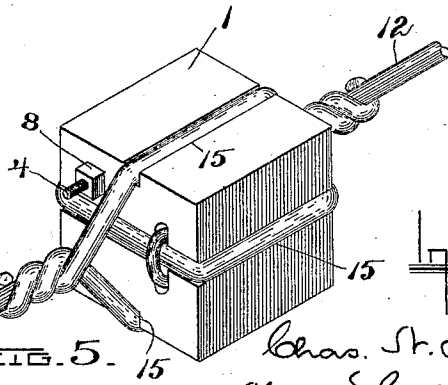

FIG. 5.

WITNESSES-

Arthur F. Randall
Robert Wallace.

INVENTOR.

Chas. N. Hammond
by Maceo Calver & Randall
his Attorneys

UNITED STATES PATENT OFFICE.

CHARLES N. HAMMOND, OF BOSTON, MASSACHUSETTS.

INSULATOR.

SPECIFICATION forming part of Letters Patent No. 524,850, dated August 21, 1894.

Application filed December 18, 1893. Serial No. 493,938. (No model.)

To all whom it may concern:

Be it known that I, CHARLES N. HAMMOND, a citizen of the United States, residing at Boston, in the county of Suffolk and State of Massachusetts, have invented certain new and useful Improvements in Insulators, of which the following is a specification, reference being had therein to the accompanying drawings.

The invention will be described first with reference to the accompanying drawings, after which the characteristic features thereof will be particularly pointed out and distinctly defined in the claims at the close of this specification.

In the drawings, Figure 1 is a view in elevation, partly in section, showing a simple block insulator embodying my invention. Fig. 2 shows in elevation an insulator fitted for use in supporting the guard wire for the trolley-wire of an electric railway. Fig. 3 shows the said insulator turned quarter way round. Fig. 4 shows the same in plan. Fig. 5 is an isometric showing a strain insulator embodying my invention.

At 1 in the several figures of the drawings is a mass or block of some suitable material, such, for example, as porcelain, capable of effecting electrical insulation. This mass or block is given such general form or shape as is required in order to fit the same for the use to which the insulator of which it constitutes a part is intended to be applied. In the surface of the said mass or block is or are formed one or more wire-receiving grooves or depressions 2. At one side of the groove or depression 2 is a hole 3 for the reception of the stem 4 of a wire-retainer, the latter having a head 5, which overlies the wire in the groove or depression 2, so as to engage therewith and hold it in the said groove or depression. The stem 4 has combined therewith a securing device for keeping the wire-retainer in place, and causing its head to bear properly against the wire. The preferred construction and arrangement of securing means is shown in the drawings, wherein the said stem is represented as threaded at 7, and has applied thereto a nut 8. The said nut is intended to be turned up tightly against the proximate surface of the mass or block 1, as indicated in the drawings, so as to force the head 5

into firm contact with the exterior of the wire and press the wire into the bottom of the groove or depression 2. The head 5 is formed hook-shaped as shown, the down-turned point or free extremity 9 of the hook receiving the wire between it and the stem 4, and entering a hole 10 on the side of the groove or depression 2 which is opposite that on which hole 3 is formed. The said point or free extremity 9 cannot be withdrawn from the hole 10 by any force or strain exerted on the wire and tending to straighten the head out into line with the stem, inasmuch as the contact of the sides of the said down-turned point or free extremity with the sides of the said hole will act to prevent the swinging movement which necessarily is incident to the straightening-out.

The invention may be embodied in a variety of insulators of different types and forms, which latter may be supported in any required or convenient manner. Thus, Fig. 1 shows a simple block insulator having a single groove and corresponding wire-retainer, and it being intended to be held or mounted on a suitable support in any desired manner.

Figs. 2, 3 and 4 show an insulator which I have devised for use with the guard-wires which are located above the trolley-wires of an electric railway, and in similar connections. It has one wire-receiving groove in the upper surface thereof, in which is shown secured the usual span-wire 11 which serves for the support of the insulator, and a second wire-receiving groove in the under surface thereof in which is shown secured the guard-wire 12. The two wires usually occupy positions at right angles to each other, and accordingly the two grooves shown in this figure are thus formed. As will be observed, the threaded end of the retainer for the span-wire projects downwardly through the material of the block, entirely to one side of the guard wire, while the corresponding end of the retainer for the guard-wire projects upwardly through the material of the block, entirely to one side of the span-wire, so that there is no electrical connection between the wires through the retainers and their securing devices.

Fig. 5 shows a simple form of strain insu-

lator, having applied thereto the two parts 12, 13 of a span wire, and differing from the insulator of Figs. 2, 3 and 4 in having grooves 15, 15 formed in the sides thereof for the reception of the side-portions of the loops which are formed in the said parts 12, 13 of the span-wire, the said side-grooves 15, 15 preventing displacement of the said loops. Each part of the span-wire is simply passed around the block, being seated in the grooves and engaged by the respective retainers, and has the free end thereof twisted around the main portion of such part, as shown.

What I claim is--

1. An insulator comprising a mass or block of suitable material formed with a wire-receiving groove or depression and holes on opposite sides of such grooves or depression, a wire-retainer having a stem which is placed in one of said holes and a hook-shaped head which over-lies the wire in the groove or depression and has its down-turned point entered into the other of the said holes, and a securing device applied to the said stem, substantially as described.

2. An insulator comprising a block of suitable material formed with a wire-receiving groove or depression and holes on opposite sides of such groove or depression, a wire-retainer having a threaded stem which is placed in one of said holes and a hook-shaped head over-lies the wire in the groove or depression and has its down-turned point entered into the other of the said holes, and a nut applied to the threaded part of the stem and adapted to be turned up against the surface of the block, substantially as described.

3. An insulator comprising a mass or block

of suitable material formed on opposite surfaces thereof with wire-receiving grooves or depressions at an angle to each other, a hole in the said mass or block at the side of each of such grooves or depressions, a wire-retainer for each of the wire-receiving grooves, each wire-retainer having a stem which is placed in the hole adjacent to the corresponding groove or depression, and a securing device for each wire-retainer applied to the stem of the latter, the stems of the wire-retainers extending in opposite directions through the mass or block, substantially as described.

4. An insulator comprising a mass or block of suitable material formed on opposite surfaces thereof with wire-receiving grooves or depressions at an angle to each other, holes in the said mass or block at the opposite sides of each of such grooves or depressions, a wire-retainer for each of the wire-receiving grooves, each wire-retainer having a stem which is placed in a hole at one side of the corresponding groove and a hook-shaped head which over-lies the wire in the groove or depression and has its down-turned point entered into the hole at the other side of the said groove or depression, and a securing device for each wire-retainer applied to the stem of the latter, the stems of the wire-retainers extending in opposite directions through the mass or block, substantially as described.

In testimony whereof I affix my signature in presence of two witnesses.

CHARLES N. HAMMOND.

Witnesses:

WM. A. MACLEOD,
CHAS. F. RANDALL.