

H. L. MAY.  
Wind-Mill.

No. 208,254.

Patented Sept. 24, 1878.

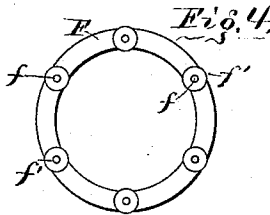
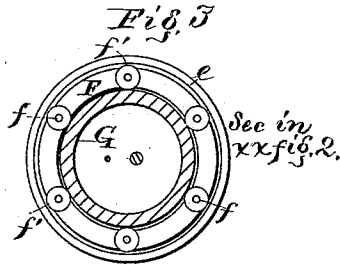
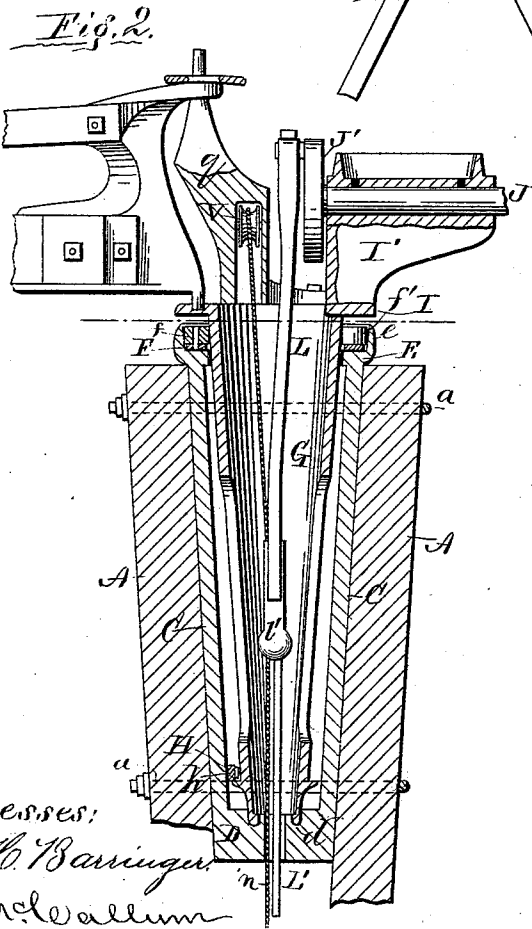
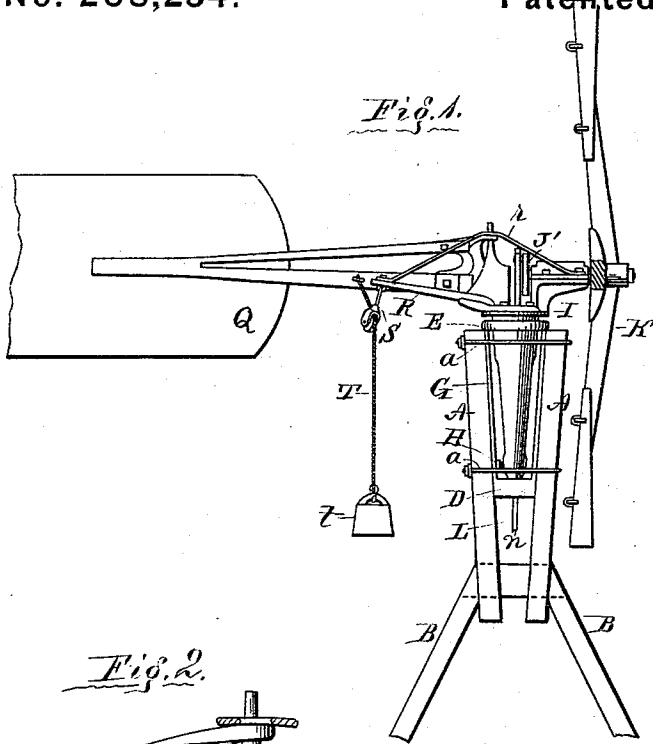

Witnesses:  
*W. H. Barington*  
*A. McCallum*

Inventor:  
*Harvey S. May,*  
*By W. B. Richards,*  
*Att'y.*

H. L. MAY.  
Wind-Mill.

No. 208,254.

Patented Sept. 24, 1878.

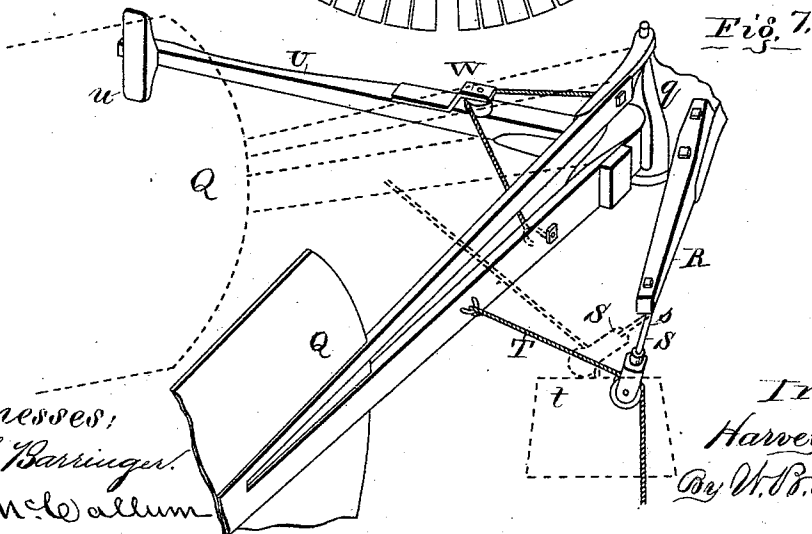
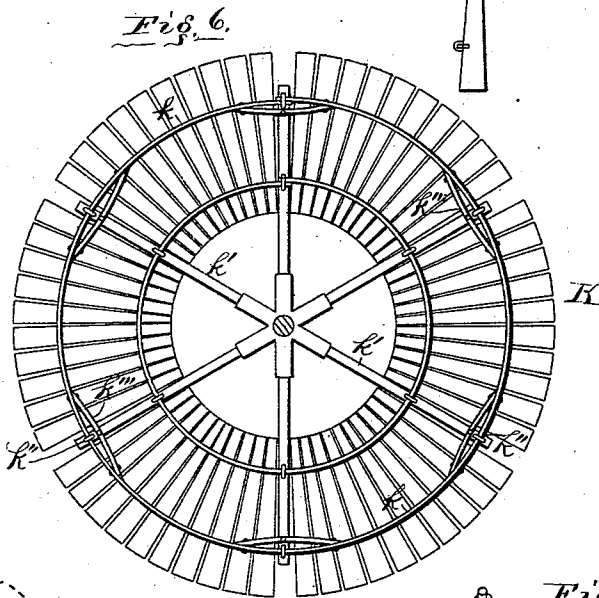
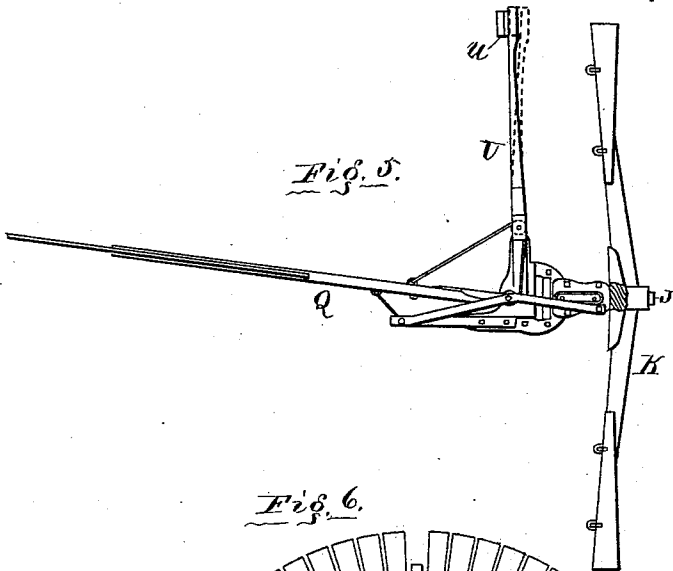

Witnesses:  
*W. H. Barringer.*  
*A. M. C. Allen*

Inventor:  
*Harvey L. May,*  
*By W. P. Richards,*  
*Atty.*

H. L. MAY.  
Wind-Mill.

No. 208,254.

Patented Sept. 24, 1878.

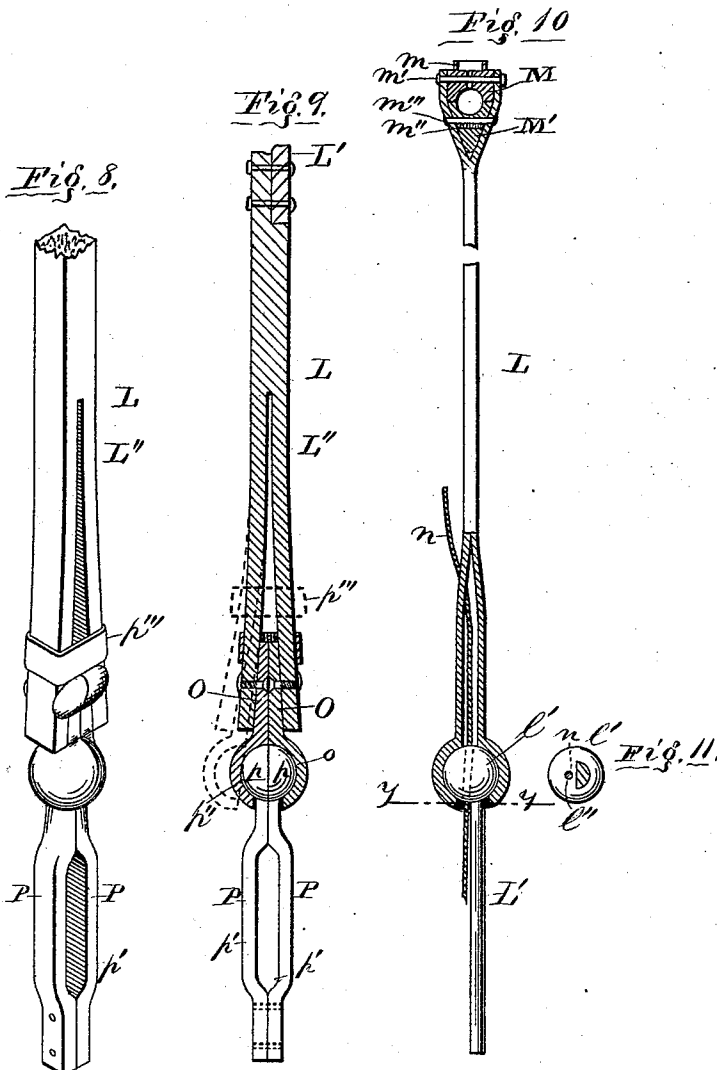

Witnesses:  
W. H. Barringer  
A. McCallum

Inventor:  
Harvey L. May,  
By W. B. Richards,  
Atty.

# UNITED STATES PATENT OFFICE.

HARVEY L. MAY, OF GALESBURG, ILLINOIS.

## IMPROVEMENT IN WINDMILLS.

Specification forming part of Letters Patent No. 208,254, dated September 24, 1878; application filed March 29, 1878.

*To all whom it may concern:*

Be it known that I, HARVEY L. MAY, of Galesburg, in the county of Knox and State of Illinois, have invented certain new and useful Improvements in Windmills; and I do hereby declare that the following is a full, clear, and exact description thereof, which will enable others skilled in the art to which it appertains to make and use the same, reference being had to the accompanying drawings, and to letters of reference marked thereon, which form a part of this specification, in which—

Figure 1 is a side elevation, partly broken away, of a windmill embodying my invention. Fig. 2 is a vertical sectional view of the turntable and upper part of the tower. Figs. 3 and 4 are detail views hereinafter referred to. Fig. 5 is a top-plan view. Fig. 6 is an elevation of the rear side of the wind-wheel. Fig. 7 is a perspective view of the vane and adjacent parts. Fig. 8 is a detail perspective view of the lower part of the connecting-rod. Fig. 9 is a vertical sectional view of Fig. 8. Fig. 10 is a sectional view of the upper part of the connecting-rod. Fig. 11 is a sectional view in the line *y y* in Fig. 10, seen from below.

My invention relates to improvements in that class of windmills in which the sail-wheel rotates a horizontal shaft, which is mounted on a vertical axis, to which the vane is hinged in such manner that the wheel is deflected and turned "edge to" by strong blasts of wind, while the vane holds the parts in position by remaining "in the wind;" and the invention consists, first, in the use of a suspended pulley, in combination with the weighted cord or chain which returns the wheel to its normal position after each deflection by an increase of wind; second, in the use of a yielding spring-arm, against which the vane strikes when the wheel is deflected by an increase of wind; third, in improvements relating to the union of the coupling-rod to the pump; fourth, in improvements in the bearings of the wheel-shaft in the connecting-rod.

Referring to the drawing by letters, A A represent two bars, diverging at their upper ends, and their lower ends converging, and secured to each other by bands *a a*, and together forming the upper part of the tower, their lower

ends being secured in any desired manner in the upper ends of bracing-posts B.

C C are metal plates, secured one to each bar A, connected at their lower ends by a cross-piece, D, and at their upper ends by a ring-shaped plate, E, which has an annular flange, *e*, extending upward around its outer edge.

F is a ring-shaped plate, with short studs *f*, on each of which is journaled a small wheel, *f'*, the diameter of which is such that the wheels *f'* extend over the inner and outer sides of the ring F, (see Fig. 4,) so that when the ring F is seated loosely over the plate E the outer sides of the wheels *f'* will rest against the flange *e*. (See Figs. 2 and 3.)

G is a conical tubular shaft, which constitutes the rotating part of the turn-table, its lower end stepped in an annular bearing-groove, *d*, in the bar D, as shown at Fig. 2, which bearing-groove will receive and retain oil, and its upper end and sides bear against the inner sides of the wheels *f'*, which wheels *f'* turn on their axes as the shaft G rotates, and are revolved in a path around the ring-track E, their outer sides rolling against the inner side of the flange *e*, and thus with minimum friction holding the shaft G in a vertical position, while its weight and the weight of attached parts rest in the bearing *d*.

The shaft G is secured against vertical displacement by means of a guard, H, which is bolted to the inner side of one of the plates C, and rests above an annular ledge, *h*, on the exterior of the shaft G.

I is an annular flange on the upper end of the shaft G, which serves to cover and protect the wheels *f'*, and from which projects upwardly an ordinary standard and bearing I', in which is journaled the wheel-shaft J, on the outer end of which is fixed the wind-wheel K, which is dished, as shown by the sectional view thereof at Fig. 1, and hangs close at its lower side to the contracted part of the bars A, thus bringing the wheel close to the vertical axis on which it rotates by a simple construction of the tower-top, as hereinbefore described.

The wheel K has ordinary bands *k*, to which the sails are attached, and which are attached themselves to the radial arms *k'*. The bands

*k* are made in sections, united at each radial arm *k'* by a stirrup, *k''*, and a brace, *k'''*, which brace is bolted at each end to the band *k*, and at its central part to a radial arm, *k'*, as shown at Fig. 6.

*J'* is the ordinary crank-wheel on the shaft *J*, from which a connecting-rod, *L*, extends downward to connect with a pump-rod. The bearing in the connecting-rod *L* on the crank-pin of wheel *J'* is shown at Fig. 10, and consists of an upper bearing-block or half-box, *M*, with an oil-cup, *m*, secured between the forked ends of the rod *L* by a bolt, *m'*, the lower half-box *M'* being tapering, and having a transverse slot, *m''*, through which a bolt, *m'''*, passes, by means of which it may be adjusted to compensate for wear in the evident manner. Mid-length the rod *L* is bifurcated, and a hemispherical cavity formed on each branch, between which cavities a spherical ball, *l'*, is received, which ball *l'* is carried on the upper end of a half-round iron rod, *L'*, which constitutes the middle portion of the rod *L*. The ball *l'* has a hole, *l''*, through which the furling-cord *n* passes, as shown at Fig. 11. The rod *L'* being to one side of the ball *l'*, as shown at same figure, permits the cord *n* passing through near the center of the ball *l'*. The lower end of the rod *L'* is attached to a rod, *L''*, the lower end of which is bifurcated, and to each branch is bolted a plate, *O*, having a hemispherical cavity, *o*, in its lower end. *P P* are two plates, with a hemisphere, *p*, on the upper end of each, and a bend, *p'*, such that when the plates *P* are bolted together at their lower ends the bends *p'* will form a slot, which receives and is secured permanently to the upper end of an ordinary pump-rod. The hemispheres *p* brought together form a sphere, *p''*, which is received between the hemispherical cavities *o*. The sphere *p''* is held by sliding the loop *p'''* downward on the rod *L''*, and when it is desired to disconnect the windmill from an attached pump it may be readily and easily done by sliding the loop *p'''* upward, as shown at Fig. 9, when the rod *L''* may be released from the plates *P*.

*Q* is the vane, hinged to standards *q* on the upper end of the shaft *G*. *R* is an arm projecting from the upper end of the shaft *G*, stayed by a brace, *r*, and has a pulley, *S*, which is preferably weighted, hung on its outer end by a swiveled rod, *s*, which permits the pulley to swing or vibrate to a horizontal position. *T* is a cord which passes over the pulley *S*, and has a weight, *t*, at one end, and is attached at its other end to the side of the vane *Q*. *U* is an arm, made of material which allows it to yield or spring back, as shown at

Fig. 5, and is mounted on the upper end of the shaft *G* in the ordinary manner, so that when the wheel *K* is deflected by a blast of wind the vane *Q* will strike the block *u* on the outer end of the arm *U* and hold the wheel *K* edge to the wind. The spring in the arm *U* is intended to relieve the shock when the vane and arm are thus brought forcibly together. The force of their approach is also diminished by the action of the pendent pulley *S*, the cord *T* being made of such length that the weight *t*, or some other stop provided on said cord, will reach the pulley *S* a short time before the vane *Q* reaches the arm *U*, and the increased resistance then offered by drawing the pulley and cord out of their vertical positions, as shown at Fig. 5, will tend to diminish the velocity of the approaching vane *Q* and arm *U*, and thus diminish the force of their contact.

The furling-rod *n* passes upward through the ball *l'*, as already described, and over a pulley, *V*, above the shaft *G*, and thence over a pulley, *W*, on the arm *U* to the vane *Q*, its lower end being carried downward to where it may be taken hold of, and drawn in the ordinary manner to deflect the wheel *K*, or to lock it "out of the wind," when desired.

What I claim as new is—

1. In a windmill, a conical tubular shaft, *G*, stepped in an annular groove in a transverse bearing-block, *d*, at its lower end, and against the wheels *f'* at its upper end, substantially as described, and for the purpose specified.
2. In a windmill, a suspended vibrating pulley, *S*, arranged to operate with a weighted cord, *T*, arm *R*, vane *Q*, and wheel *K*, so as to offer an increasing resistance as the wheel is deflected by the wind, substantially as and for the purpose specified.
3. The yielding spring-arm *U*, arranged to operate with the vane *Q* and wheel *K*, as and for the purpose specified.
4. The plates *P P*, removably attached to the rod *L''* by means of the sliding loop or bridle-bar *p'''*, arranged to operate with the bifurcated ends of the rod *L''*, and the plates *P*, substantially as and for the purpose specified.
5. The sliding slotted box *M* and bolt *m'''*, arranged to operate with the forked rod *L*, box *M*, and crank-wheel pin, substantially as and for the purpose specified.

In testimony that I claim the foregoing as my own I affix my signature in presence of two witnesses.

HARVEY L. MAY.

Witnesses:

M. H. BARRINGER,  
THOMAS MCKEE.