



US 20080020348A1

(19) **United States**

(12) **Patent Application Publication**
HANSSON

(10) **Pub. No.: US 2008/0020348 A1**

(43) **Pub. Date: Jan. 24, 2008**

(54) **IMPLANT**

(30) **Foreign Application Priority Data**

Jul. 17, 1998 (SE)..... 9802571-1

(75) Inventor: **Stig HANSSON**, Askim (SE)

Publication Classification

Correspondence Address:
**FINNEGAN, HENDERSON, FARABOW,
GARRETT & DUNNER
LLP
901 NEW YORK AVENUE, NW
WASHINGTON, DC 20001-4413 (US)**

(51) **Int. Cl.**

A61C 17/00 (2006.01)

A61F 2/02 (2006.01)

(52) **U.S. Cl.** **433/173; 433/174; 623/17.17**

(57)

ABSTRACT

Implant (10) having a shaft which is adapted in use to be embedded in bone tissue and which has an outer surface provided with a circumferentially-oriented roughness. The circumferentially-oriented roughness has first and second axial sections (19, 21) with each section comprising a series of circumferentially-oriented peaks which have a crest and which are axially spaced apart by troughs. The axial spacing (d) between the crests of adjacent peaks in the first axial section (19) is less than the axial spacing (3d) between the crests of adjacent peaks in the second axial section (21). Although the axial spacing between the crests of adjacent peaks in the first and second axial sections of circumferentially-oriented roughness differs, the first and second axial sections of circumferentially-oriented roughness are adapted in use to provide the same or substantially the same pitch.

(73) Assignee: **AstraZeneca AB**

(21) Appl. No.: **11/828,523**

(22) Filed: **Jul. 26, 2007**

Related U.S. Application Data

(63) Continuation of application No. 10/361,383, filed on Feb. 10, 2003, now Pat. No. 7,264,470, which is a continuation of application No. 09/402,918, filed on Oct. 13, 1999, now Pat. No. 6,547,564, filed as 371 of international application No. PCT/SE99/01272, filed on Jul. 14, 1999.

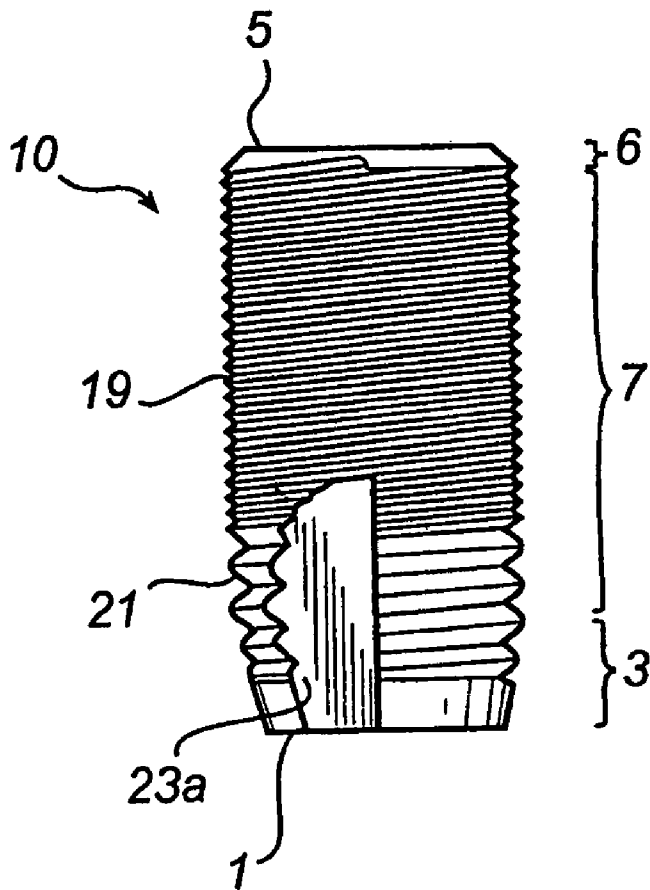

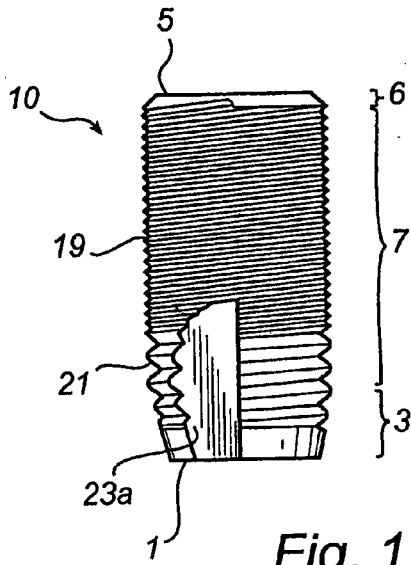

Fig. 1

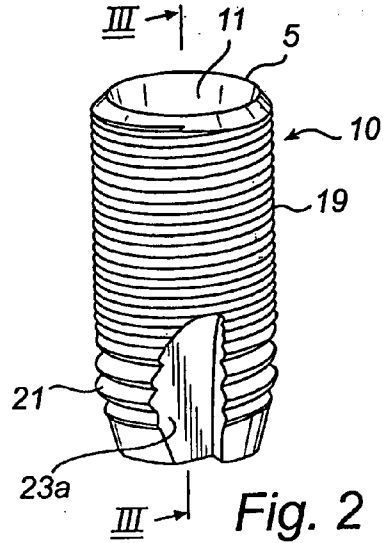

Fig. 2

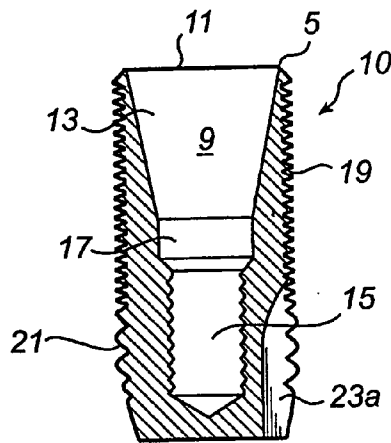

Fig. 3

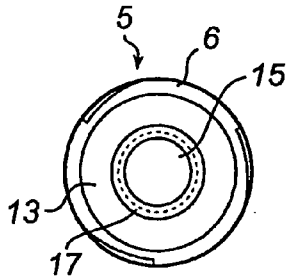

Fig. 4

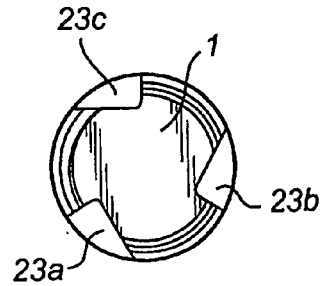

Fig. 5

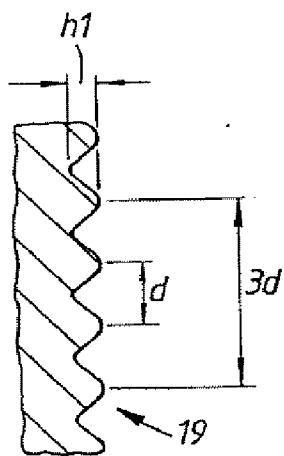

Fig. 6

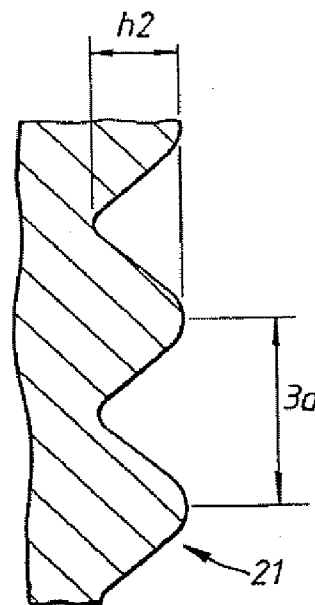

Fig. 7

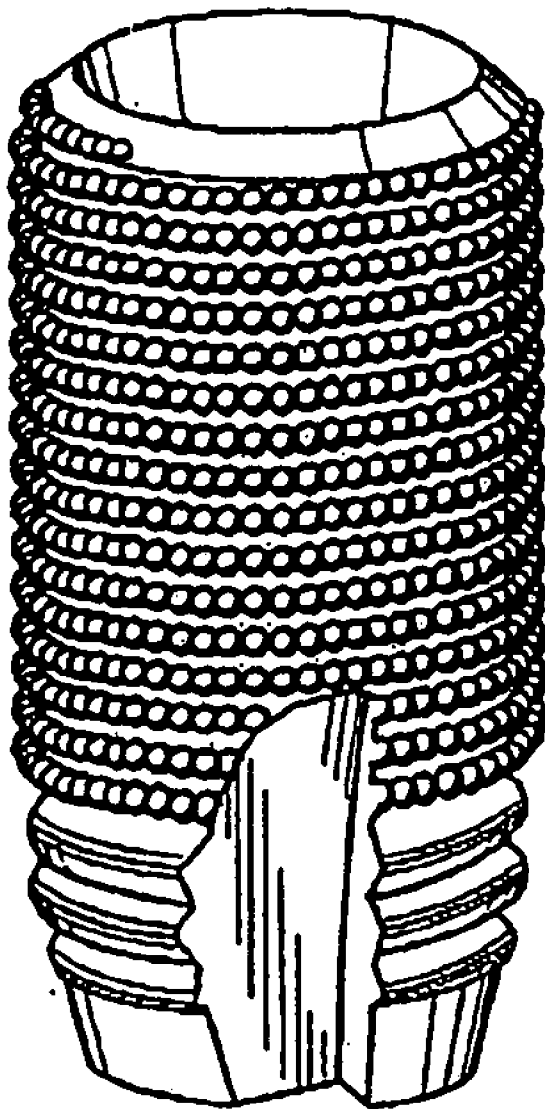

Fig. 8

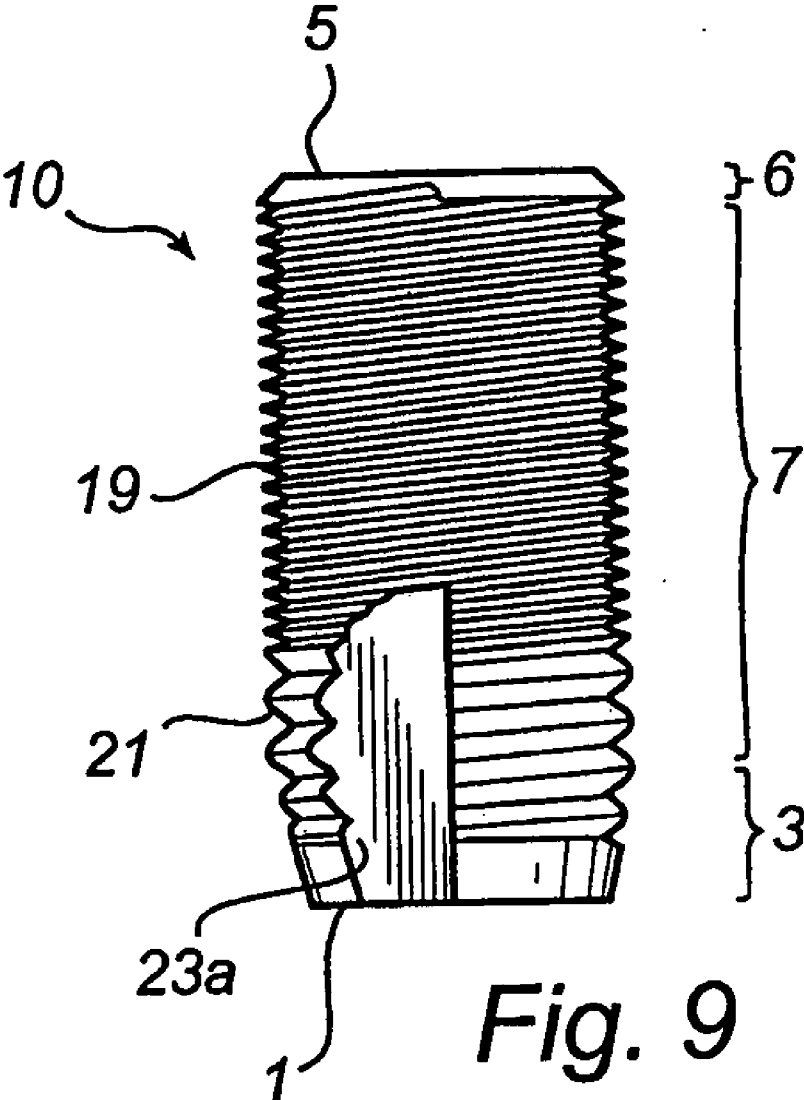

Fig. 9

IMPLANT

FIELD OF THE INVENTION

[0001] The present invention relates to an implant having a shaft which is adapted in use to be embedded in bone tissue and which has an outer surface provided with a circumferentially-oriented roughness. This will hereinafter be referred to as an “implant of the type defined”.

BACKGROUND OF THE INVENTION

[0002] Implants of the type defined are known for use as the anchoring members of dental and orthopaedic prostheses. To this end, the implant is inserted into a bore-hole drilled into the bone tissue of a bone tissue structure at a site where a prosthesis is required, ordinarily by screwing of the implant into the bore-hole. The convention in the art is for the circumferentially-oriented roughness to take the form of a screw thread and in this case the bore-hole will ordinarily be (i) provided with internal threads in advance, or (ii) left un-tapped with the implant being provided with a self-tapping capacity, e.g. by the provision of one or more axially-extending cutting recesses or notches in the screw thread.

[0003] A superstructure having the prosthetic part of the prosthesis is then secured to the implant. In the case of a dental prosthesis, the superstructure will typically consist of a spacer or transmucosal component which engages to the implant to bridge the gingiva overlying the maxilla or mandible at the implant site and the prosthetic part, e.g. a crown, bridge or denture, is then secured to the spacer. There are various other forms that the superstructure can take as is known in the art. For instance, the prosthetic part may be secured directly to the implant.

[0004] The long-term integrity of the prosthesis is highly dependent on the successful osseointegration of the implant with the bone tissue structure, that is to say, the remodelling of the bone tissue in the bone tissue structure into direct apposition with the implant. A study on the factors which affect the osseointegration of implants was undertaken by Professor Per-Ingvar Brånemark and co-workers and the results were published in a book entitled “*Osseointegrated Implants in the Treatment of the Edentulous Jaw: Experience from a 10-Year Period*”. *Almqvist & Wiksell International. Stockholm, Sweden, 1977*. It was found by Brånemark et al that successful osseointegration depends upon inter alia the use of biocompatible materials for the implant, for example titanium and alloys thereof, and the surgical procedure adopted, for example leaving the implant unloaded for several months before adding the superstructure.

[0005] Implants of the type defined are not necessarily always used as part of a prosthesis, in some instances they can be a “stand alone” structure. As an example, implants of the type defined are known for use as bone fixation screws. The success of these “stand alone” implants is also highly dependent on their successful osseointegration.

[0006] Implants of the type defined have some notable advantages in promoting successful osseointegration with the adjacent bone tissue, a major one being as a result of the fact that the main loads on the implant in the clinical situation are axial loads. These implants are very well suited

to support axial loads and this may be particularly important in the initial stages of the osseointegration process in which it is important that the implant is fully stable and as immovable as possible in the borehole (primary fixation). One can consider this to be due to the bone tissue growing into the troughs between adjacent peaks of the circumferentially-oriented roughness on the implant.

[0007] The Applicant has also identified that it is advantageous for an implant of the type defined to transmit the axial loading thereon evenly to the adjacent bone tissue to prevent high stress concentrations occurring in the adjacent bone tissue and concomitantly marginal bone tissue resorption. If marginal bone tissue resorption occurs this will reduce the anchorage of the implant and may undermine the long-term stability of the implant resulting in due course in failure of the prosthesis. In the particular case of dental prostheses, the aesthetic appeal is also undermined by marginal bone tissue resorption, an important drawback since dental prosthetics forms part of the field of cosmetic surgery.

[0008] The present invention proposes to provide an implant of the type defined having features which promote its maintenance in a bone tissue structure whilst at the same time facilitating its insertion into the bone tissue structure in the first place.

SUMMARY OF THE INVENTION

[0009] According to the present invention there is provided an implant of the type defined in which the circumferentially-oriented roughness has first and second axial sections each comprising a series of circumferentially-oriented peaks which have a crest and which are axially spaced apart by troughs, the axial spacing between the crests of adjacent peaks in the first axial section is less than the axial spacing between the crests of adjacent peaks in the second axial section and the first and second axial sections of circumferentially-oriented roughness are adapted in use to provide the same or substantially the same pitch.

[0010] The larger inter-peak spacing in the second axial section of circumferentially-oriented roughness acts to promote primary fixation of the implant in the bone tissue during the early phases of osseointegration since each trough between adjacent peaks can capture a relatively large volume of bone tissue to interlock the implant with the bone tissue. The smaller inter-peak spacing in the first axial section, on the other hand, enables the stiffness of the implant to be increased thereby improving the ability of the implant to transmit loads more evenly to the bone tissue to inhibit marginal bone resorption. Adapting the first and second axial sections to have the same or substantially the same pitch means that both axial sections produce the same or substantially the same axial displacement into the bone tissue on one rotation thereof thus ensuring that the provision of the two different axial sections of circumferentially-oriented roughness does not complicate insertion of the implant into the bone tissue. If the first and second axial sections of circumferentially-oriented roughness did not have the same or substantially the same pitch then a greater force would need to be applied to insert the implant resulting in fractures being formed in the bone tissue.

[0011] In an embodiment of the invention such as the one hereinafter to be described the pitch is a predetermined distance, the ratio of the predetermined distance to the axial

spacing between the crests of adjacent peaks in the first axial section is a first multiple integer and the ratio of the predetermined distance to the axial spacing between the crests of adjacent peaks in the second axial section is a second multiple integer which is less than the first multiple integer. The first multiple integer may be a multiple integer of the second multiple integer.

[0012] In an embodiment of the invention such as the one hereinafter to be described the peaks in the first and second axial sections are circumferentially-oriented at a common inclined angle to the main axis of the implant.

[0013] In an embodiment of the invention such as the one hereinafter to be described the shaft has a coronal end and an apical end and the first axial section is located coronally of the second axial section.

[0014] In an embodiment of the invention such as the one hereinafter to be described the first and second axial sections are contiguous.

[0015] In an embodiment of the invention such as the one hereinafter to be described the first axial section extends from the coronal end of the shaft to a position coronally of the apical end and the second axial section extends from the first axial section towards the apical end of the shaft. The implant may have a coronal end which is spaced coronally from the coronal end of the shaft by a smooth coronal portion of the implant, as in the embodiment of the invention hereinafter to be described, in which case the smooth coronal portion is preferably no more than 4% of the total length of the implant, more preferably in the range 1.5-3.7% of said total length. In an embodiment of the invention such as the one hereinafter to be described the axial extent of the first axial section is greater than the axial extent of the second axial section. Alternatively, the axial extent of the first axial section may be less than the axial extent of the second axial section or the axial extents of the first and its second axial sections may be the same or substantially the same.

[0016] In an embodiment of the invention in which the first axial section is disposed coronally of the second axial section, such as the one hereinafter to be described, a blind bore extends apically into the shaft from the coronal end thereof to an end surface in-between the apical and coronal ends of the shaft for a superstructure to be secured to the implant, the blind bore comprising an internally-threaded section having a coronal edge and an apical edge for screw connection of the superstructure to the implant with the apical edge terminating at a position which is disposed apically of the first axial section. Alternately, the apical edge of the internally-threaded section of the blind bore may terminate at a position which is disposed coronally of the second axial section. The internally-threaded section may be an apical section of the blind bore, as in the embodiment of the invention hereinafter to be described.

[0017] In an embodiment of the invention such as the one hereinafter to be described all or substantially all of the crests of the peaks in the first and second axial sections lie on an axial plane parallel to the main axis of the shaft. Expressed another way, the major transverse dimension of the implant at the first and second axial sections is uniform.

[0018] In an embodiment of the invention such as the one hereinafter to be described the height of the peaks, as

measured from the troughs to the crests, in the first axial section differs from that in the second axial section. To advantage, the height of the peaks in the first axial section is less than that in the second axial section. This feature further enables the stiffness of the implant to be increased.

[0019] In an alternative embodiment of the invention the height of the peaks, as measured from the troughs to the crests, in the first axial section is the same or substantially the same as in the second axial section.

[0020] In an embodiment of the invention such as the one hereinafter to be described the ratio of the height of the peaks, as measured from the troughs to the crests, to the axial spacing between the crests of adjacent peaks in the first axial section is the same or substantially the same as in the second axial section. In an embodiment of the invention such as the one hereinafter to be described the height of the peaks, as measured from the troughs to the crests, in the first axial section is no greater than 0.2 mm, for example in the range 0.02-0.20 mm, and the height of the peaks, as measured from the troughs to the crests, in the second axial section is greater than that in the first axial section, for instance in the range 0.15 mm to 1 mm. Such heights complement the primary fixation and stiffness characteristics of the implant provided by the different inter-peak spacings of the first and second axial sections.

[0021] In an embodiment of the invention such as the one hereinafter to be described the peaks in the first and second axial sections are bounded by flank surfaces and the angle between the opposed flanks of adjacent peaks in the first and second axial sections is the same.

[0022] In an embodiment of the invention such as the one hereinafter to be described the troughs in at least one of the first and second axial sections are a continuous curved surface.

[0023] In an embodiment of the invention such as the one hereinafter to be described the circumferentially-oriented roughness in the first and/or second axial section is presented by a screw thread profile with the circumferentially oriented peaks being defined by thread elements of the screw thread profile.

[0024] Typically, the screw thread profile of the first and/or second axial section will be formed by a screw thread structure. In such case, the screw thread structure of the first axial section may be formed by a first set of independent screw threads each having turns; the turns of each independent screw thread in the first set defining thread elements in the first axial section and being sequentially arranged with the turns of the other independent screw threads in the first set with adjacent turns of one of the independent screw threads of the first set being axially-spaced apart by a predetermined spacing distance which is the same for adjacent turns of the other independent screw threads in the first set; and the screw thread structure of the second axial section may be formed by (i) an independent screw thread having turns which define the thread elements of the second axial section and are axially-spaced apart by the predetermined spacing distance or essentially the predetermined spacing distance, or (ii) a second set of independent screw threads numbering less than in the first set each having turns, the turns of each independent screw thread in the second set defining thread elements in the second axial section and

being sequentially arranged with the turns of the other independent screw threads in the second set with adjacent turns of each independent screw thread of the second set being axially-spaced apart by the predetermined spacing distance or essentially the predetermined spacing distance.

[0025] In an embodiment of the invention one or more of the independent screw threads of the first and second axial sections are shared by the first and second axial sections.

[0026] In an embodiment of the invention such as the one hereinafter to be described the or each independent screw thread of at least one of the first and second axial sections is a microthread, that is to say, a thread having a height which is no greater than 0.2 mm.

[0027] In an embodiment of the invention only the screw threads of the first axial section are microthreads. It could be the case, though, that the screw threads of both the first and second axial sections are microthreads.

[0028] In an embodiment of the invention the circumferentially-oriented roughness in at least one of the first and second axial sections is formed by a series of axially spaced-apart circumferential lines of beads. The beads in each line may be circumferentially spaced-apart.

[0029] In an embodiment of the invention such as the one hereinafter to be described the implant is a dental implant adapted for implantation in the maxilla or mandible of an edentulous patient for supporting a superstructure which presents one or more artificial teeth.

[0030] According to the invention there is further provided a method of implanting an implant into a bone tissue structure comprising the steps of providing an implant according to the invention, providing a bore-hole in the bone tissue structure and screwing the implant into the bore-hole so that the shaft is embedded in the bone tissue.

BRIEF DESCRIPTION OF THE DRAWINGS

[0031] By way of example, a self-tapping endosseous screw-type dental implant in accordance with the present invention will now be described with reference to the accompanying Figures of drawings in which:

[0032] FIG. 1 is a side view of the dental implant;

[0033] FIG. 2 is a perspective view of the dental implant;

[0034] FIG. 3 is a cross-sectional side view of the dental implant;

[0035] FIG. 4 is a plan view of the dental implant;

[0036] FIG. 5 is an underneath view of the dental implant;

[0037] FIG. 6 is an exploded view of a first section of the external screw threading on the dental implant; and

[0038] FIG. 7 is an exploded view of a second section of the external screw threading on the dental implant.

DESCRIPTION OF EXEMPLARY EMBODIMENT OF THE INVENTION

[0039] In the accompanying Figures of drawings there is shown various views of a self-tapping endosseous screw-type dental implant 10 of a dental prosthesis in accordance with the present invention. The implant 10 is for insertion into a bore-hole drilled into a toothless-site in a maxilla or

mandible of a partially or fully edentulous patient to anchor to the maxilla or mandible a superstructure of the prosthesis which comprises a prosthetic part, namely one or more artificial teeth. The implant 10 is made from commercially pure titanium, a titanium alloy, another biocompatible metal or metal alloy or a ceramic to promote osseointegration of the implant with the bone tissue of the boundary walls of the bore-hole.

[0040] Referring to FIG. 1, the implant 10 has an apical end 1 which is presented by a first conical section 3 to ease insertion of the implant 10 into the bore-hole, a coronal end 5 presented by a second conical section 6 and an intermediate section 7 of constant diameter which extends between the first and second conical sections 3, 6.

[0041] The length of the implant may be in the range 8-19 mm, depending on the clinical situation, and have a maximum outer diameter of 3.5 mm or 4.0 mm. The axial extent of the second conical portion 6 is preferably small compared to the total length of the implant 10, as an example no more than 4.0% perhaps in the range 1.5%-3.7%.

[0042] Turning to FIGS. 2 to 4, a socket 9 having an open end 11 in the coronal end 5 extends apically into the implant 10. The socket 9 is for receiving an abutment structure (not shown) which will bridge the gingiva overlying the bore-hole and support/present the prosthetic part. The socket 9 consists of a conical coronal section 13, an internally-threaded apical section 15 and a cylindrical intermediate section 17. The abutment structure will have an apical section which is able to be screw retained in the implant socket 9 for releasably securing the abutment structure to the implant 10.

[0043] As shown in FIGS. 1 to 3, 6 and 7, the outer surface of the implant 10 over the major part of its length is provided with screw threading which is divided into coronal and apical sections 19, 21 having different thread heights h_1 , h_2 . As shown most clearly in FIG. 1, the coronal section 19 of screw threading is positioned on the intermediate cylindrical section 7 of the implant 10 whereas the apical section 21 of the screw threading bridges the intermediate cylindrical section 7 and the first conical section 3.

[0044] Referring to FIG. 6, the screw threading in the coronal section 19 is composed of a series of axially spaced-apart screw thread elements each having the same height h_1 . These screw thread elements are formed by the turns of three separate microthreads (triple microthread) which are sequentially arranged. This means that a screw thread element formed by a first turn of one of the microthreads is axially spaced from a screw thread element formed by the next turn of that microthread by two other screw thread elements, each being respectively formed by a turn of the other two microthreads. A screw thread element belonging to one of the microthreads is therefore axially spaced from the next adjacent screw thread element formed by the same microthread by screw thread elements from each of the other two microthreads. By "microthread" is meant a screw thread having a height which is no greater than 0.2 mm. Accordingly, the screw thread elements in the coronal section 19 have a height h_1 which is no greater than 0.2 mm, preferably 0.1 mm.

[0045] Referring to FIG. 7, the screw threading in the apical section 21 is composed of a series of axially spaced-

apart screw thread elements which, other than those in the first conical section 3, each have the same height h_2 . The screw thread elements of the apical section 21 are formed by the turns of a single macrothread. By "macrothread" is meant a screw thread having a height greater than 0.2 mm. Accordingly, the screw thread elements of the apical section 21 on the intermediate section 7 have a height greater than 0.2 μm , preferably 0.3 mm.

[0046] The angle formed between the coronal and apical flanks of adjacent screw thread elements is the same in both the coronal and apical sections 19, 21. Preferably the angle formed is 80°. It will also be noted from FIGS. 6 and 7 that the coronal and apical flanks of adjacent screw thread elements in the coronal and apical sections 19, 21 are connected by a curved surface, that is to say, there is no axial straight part in-between adjacent screw thread elements in the coronal and apical sections 19, 21.

[0047] As can be seen particularly from FIGS. 1 and 3, the tips of the screw thread elements of the coronal section 19 and the tips of the screw thread elements of the apical section 21 positioned in the intermediate cylindrical section 7 of the implant 10 all lie on a common plane when viewed in side section and circumscribe the circumference of the cylindrical intermediate section 7. In other words, the major diameter of the intermediate cylindrical section 7 is constant.

[0048] As shown in FIGS. 6 and 7, as well as the screw thread elements in the coronal and apical sections 19, 21 having different heights from one another the crest-to-crest spacing between adjacent screw thread elements in the coronal section 19 is different from the crest-to-crest spacing between adjacent screw thread elements in the apical section 21. The crest-to-crest spacing in the coronal section 19 is d whereas the crest-to-crest spacing in the apical section 21 is $3d$. As an example, d may be 0.22 mm. In the case where h_1 is 0.1 mm and h_2 is 0.3 mm the ratio of the inter-crest spacing to the height would thus be the same for both the coronal and apical threaded sections 19, 21, namely $d/h_1 = 2.2 = 3d/h_2$.

[0049] It follows from the above that the crest-to-crest spacing between adjacent screw thread elements of each micro thread is the same as that between adjacent screw thread elements of the macrothread, namely $3d$. The fact that the crest-to-crest spacing between adjacent screw thread elements per se in the coronal section 19 is less than that in the apical section 21 is, of course, due to adjacent turns of each microthread being interspersed with a turn from each of the other two microthreads. It will also be noted from FIG. 1 that the turns of the microthreads and the macrothreads are aligned parallel with one another at an inclined angle to the rotational axis of the implant 10.

[0050] It will gathered from the above that the pitch of the coronal and apical threaded sections 19, 21 will be the same, again being $3d$. For this reason, the pitch of the implant 10 remains uniform along its length notwithstanding the difference in crest-to-crest spacing in the apical and coronal threaded sections 19, 21, that is to say, the coronal and apical screw threaded sections 19, 21 will both produce the same axial displacement of the implant 10 in the apical direction on one rotation or revolution of the implant 10 when being screwed into the borehole provided therefor at the toothless site in the maxilla or mandible. If the coronal and apical

sections 19, 21 did not have constant pitch then a greater force would need to be applied to insert the implant 10 into the bore-hole resulting in the bone threads formed in the boundary wall of the bore-hole being fractured.

[0051] As a rule, a constant pitch for two threaded sections having different crest-to-crest spacings between the adjacent screw thread elements thereof will result where the first threaded section is formed by the sequential arrangement of the turns of a first set of screw threads each having the same pitch and the second threaded section is formed by (i) a single screw thread having the same pitch as the screw threads in the first threaded section, or (ii) the sequential arrangement of the turns of a second set of screw threads numbering less than in the first set each having the same pitch as the screw threads in the first threaded section. The number of screw threads in the first threaded section does not need to be a multiple integer of the number of screw threads in the second threaded section, as in the illustrated embodiment of the invention. For example, there could be five microthreads in the coronal section 19 and two macrothreads in the apical section 21.

[0052] As shown in FIGS. 1 to 3 and 5, the implant 10 has three cutting recesses or grooves 23a, 23b, 23c positioned symmetrically about the circumference of the apical end 1 of the implant 10 for self-tapping of the implant to when being screwed into the bore-hole provided therefor in the maxilla or mandible.

[0053] In use, the implant 10 is screwed into the bore-hole provided at the toothless-site in the maxilla or mandible such that the coronal and apical sections 19, 21 are embedded in bone tissue with the second conical section 6 protruding from the maxilla or mandible. The screw thread elements of the macrothreads in the apical section 21 of the implant 10 act to provide primary fixation of the implant in the bore-hole. The screw thread elements of the microthreads in the coronal section 19 also act to provide fixation for the implant 10 in the bore-hole. As a result of the screw threads in the coronal section 19 being microthreads, though, the implant 10 is stiffer than it would be if the screw threads were macrothreads as in the apical section 21. This enables the implant 10 to transfer loads more evenly to the bone tissue adjacent the implant 10 and consequently promote better remodelling of the bone tissue into apposition with the implant 10. Moreover, as the microthreads are positioned at the coronal end 5 of the implant 10 the loads transferred thereby helps alleviate the problem of bone tissue resorption at the coronal surface of the maxilla or mandible (marginal bone tissue resorption).

[0054] The provision of micro threads in the coronal section 19 also enables a reasonable wall thickness to be retained around the tapered coronal section 13 of the socket 9 in the implant 10, when compared to the wall thickness that would result from use of macrothreads in the coronal section 19 in any event. This helps preserve the mechanical strength of the implant 10.

[0055] To conclude, the dental implant 10 has a screw threaded outer surface 19, 21 which (i) makes it straightforward for the implant 10 to be screwed into a bone tissue structure, and (ii) promotes the short- and long-term stability of the implant 10 in the bone tissue structure.

[0056] It will be appreciated that the invention has been illustrated with reference to an exemplary embodiment and

that the invention can be varied in many different ways within the scope of the appended claims. As an example, although the illustrated example is a dental implant the invention has equal application in other areas, for example, the orthopaedic area.

[0057] Finally, it is to be noted that the inclusion in the appended claims of reference numerals used in the Figures of drawings is purely for illustrative purposes and not to be construed as having a limiting effect on the scope of the claims.

1-28. (canceled)

29. A dental implant, comprising.

a shaft including a coronal end, an apical end, and an outer surface having a first axial section and second axial section, the first axial section being located coronally of the second axial section,

wherein each of the first and second axial sections comprises a series of peaks being axially spaced apart by troughs,

wherein the axial spacing between the adjacent peaks in the first axial section is less than the axial spacing between adjacent peaks in the second axial section, and

wherein substantially all of the peaks in the first axial section lie on a first axial plane parallel to the main axis of the dental implant, and substantially all of the troughs in the first axial section lie on a second axial plane parallel to the main axis of the dental implant,

wherein the second axial plane is different than the first axial plane.

30. The dental implant of claim 29, wherein the coronal end of the shaft is provided with an apically extending bore adapted for the fastening of a prosthetic component.

31. The dental implant of claim 30, wherein the bore includes an internally threaded section.

32. The dental implant of claim 30, wherein the bore includes a cylindrically-shaped section,

wherein an internally threaded section of the bore is positioned apically of the cylindrically-shaped section of the bore.

33. The dental implant of claim 30, wherein the bore includes a conically-shaped section,

wherein a cylindrically-shaped section of the bore is positioned apically of the conically-shaped section of the bore.

34. The dental implant of claim 29, wherein a coronal end of the first axial section is separated from the coronal end of the dental implant by a smooth section.

35. The dental implant of claim 34, wherein the smooth section is conically-shaped.

36. The dental implant of claim 35, wherein a conically-shaped section of the bore extends apically from a coronal end of the smooth section.

37. The dental implant of claim 35, wherein the smooth section increases in cross-sectional area in an apical direction.

38. The dental implant of claim 30, wherein the bore is a blind bore.

39. The dental implant of claim 29, wherein a height of the first axial section, from trough to crest of the peak, is different than a height of the second axial section,

wherein heights are measured in a direction perpendicular to the main axis of the shaft.

40. The dental implant of claim 29, wherein a height of the first axial section, from trough to crest of the peak, is less than a height of the second axial section,

wherein heights are measured in a direction perpendicular to the main axis of the shaft.

41. The dental implant of claim 29, wherein a height of the first axial section, from trough to crest of the peak, is about 0.2 mm or less.

42. The dental implant of claim 29, wherein the peaks of the second axial section are configured to function as a screw.

43. The dental implant of claim 29, wherein the peaks of the first axial section are configured to function as a screw.

44. The dental implant of claim 29, wherein the peaks of the first and second axial sections are configured to have substantially the same pitch.

45. The dental implant of claim 29, wherein substantially all of the peaks of the first and second axial sections are configured to be screwed into bone tissue.

46. The dental implant of claim 29, wherein the first axial section is configured to substantially inhibit marginal bone resorption.

47. The dental implant of claim 29, wherein the first and second axial sections are configured to substantially prevent fractures from being formed in bone tissue.

48. The dental implant of claim 29, wherein the peaks in the second axial section form a common angle to the main axis of the shaft.

49. The dental implant of claim 29, wherein each of the peaks includes a coronal flank and an apical flank,

wherein the coronal flank and the apical flank of each peak form an angle of about 80 degrees.

50. The dental implant of claim 49, wherein the coronal and apical flanks of each peak form a sharp edge.

51. The dental implant of claim 29, wherein a number of peaks in the first axial section per unit length of the dental implant is a multiple of a number of peaks in the second axial section per unit length of the dental implant,

wherein the multiple is an integer greater than one.

52. The dental implant of claim 29, wherein substantially all of the peaks in the second axial section lie on a third axial plane parallel to the main axis of the dental implant.

53. The dental implant of claim 52, wherein the first axial plane and the third axial plane are substantially parallel to each other.

54. The dental implant of claim 29, wherein the first axial plane and the third axial plane are substantially the same.

55. A dental implant system, comprising:

the dental implant of claim 29; and

a prosthetic component configured to be secured to the dental implant.

56. The dental implant system of claim 55, wherein the prosthetic component is selected from the group consisting of at least one of a superstructure, a spacer, an abutment structure, a transmucosal component, a crown, a bridge, a denture, one or more artificial teeth, and combinations thereof.

57. The dental implant system of claim 55, wherein the prosthetic component includes a prosthetic component

selected from the group consisting of at least one of a crown, a bridge, a denture, one or more artificial teeth, and combinations thereof,

wherein the prosthetic component also includes a superstructure selected from the group consisting of at least one of a space, an abutment structure, a transmucosal component, and combinations thereof.

58. A method of implanting a dental implant into a human jawbone, comprising:

providing the dental implant of claim 29;

boring a hole in the jawbone; and

inserting the dental implant into the bored hole of the jawbone.

59. The method of claim 58, wherein inserting the dental implant into the bored hole involves screwing the dental implant into the bored hole.

60. The method of claim 58, wherein inserting the dental implant involves screwing at least some of the peaks of the first axial section and the second axial section into the bored hole.

61. The method of claim 58, wherein the first axial section and the second axial section are inserted into the bored hole at substantially the same rate.

62. The method of claim 58, further comprising securing a prosthetic component to the dental implant.

63. The method of claim 62, wherein the prosthetic component is selected from the group consisting of at least one of a superstructure, a spacer, an abutment structure, a transmucosal component, a crown, a bridge, a denture, one or more artificial teeth, and combinations thereof.

64. A method of manufacturing a dental implant, comprising:

providing a shaft including a coronal end, an apical end, and an outer surface;

creating peaks and troughs on a first axial section of the outer surface of the shaft; and

creating peaks and troughs on a second axial section of the outer surface of the shaft, the first axial section being located coronally of the second axial section,

wherein the axial spacing between adjacent peaks in the first axial section is different than the axial spacing between adjacent peaks in the second axial section, and

wherein substantially all of the peaks in the first axial section lie on a first axial plane parallel to the main axis of the dental implant, and substantially all of the troughs in the first axial section lie on a second axial plane parallel to the main axis of the dental implant,

wherein the second axial plane is different than the first axial plane.

65. The method of claim 64, further comprising creating a bore that extends apically from the coronal end of the shaft,

wherein the bore is adapted for fastening a prosthetic component.

66. The method of claim 65, further comprising creating an internally threaded section within the bore.

67. The method of claim 65, further comprising creating a conical section within the bore.

68. The method of claim 65, further comprising creating a cylindrical section within the bore.

69. The method of claim 65, further comprising creating a smooth section between a coronal end of the first axial section and the coronal end of the dental implant,

wherein the smooth section is conically shaped and increases in cross-sectional area in an apical direction.

70. The method of claim 64, further comprising creating at least one of the peaks such that it is continuous between the first axial section and the second axial section.

71. The method of claim 64, wherein substantially all of the peaks in the second axial section lie on a third axial plane parallel to the main axis of the dental implant.

72. The method of claim 71, wherein the first axial plane and the third axial plane are substantially parallel to each other.

* * * * *