

(No Model.)

J. E. PEIRCE.
AUTOGRAPHIC REGISTERING APPARATUS.

No. 464,267.

Patented Dec. 1, 1891.

FIG. 1.

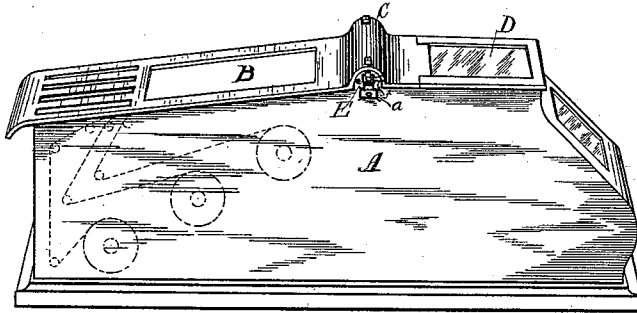

FIG. 2.

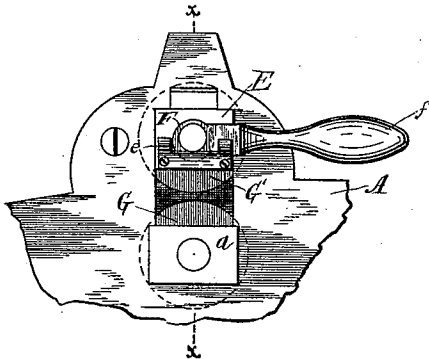

FIG. 3.

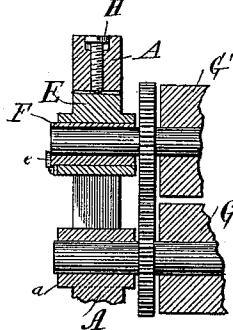
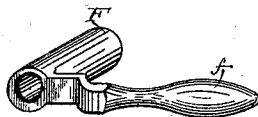

FIG. 4.



Witnesses

A. H. Hart
Frank Davis

Inventor

John E. Peirce

By his

Attorney

Cred. J. Murray

UNITED STATES PATENT OFFICE.

JOHN E. PEIRCE, OF DAYTON, OHIO.

AUTOGRAPHIC REGISTERING APPARATUS.

SPECIFICATION forming part of Letters Patent No. 464,267, dated December 1, 1891.

Application filed November 1, 1890. Serial No. 370,090. (No model.)

To all whom it may concern:

Be it known that I, JOHN E. PEIRCE, a citizen of the United States, and a resident of Dayton, in the county of Montgomery and State of Ohio, have invented certain new and useful Improvements in Autographic Registering Apparatus, of which the following is a specification.

My invention relates to that class of registering devices which are designed to preserve autographic copies of sales, bills, receipts, &c., in which a pair of feed-rolls are employed to draw strips of paper from rolls over a writing-tablet and deliver them to a severing-blade or shears. In devices of this class now in use I have found it very inconvenient to employ printed headings and ruled lines on a series of tickets, bills, or receipts printed on strips, for the reason that the different strips do not in use feed uniformly through the drawing-rolls. The strips of paper therefore require frequent adjustment to bring the printed and ruled matter upon the under strip or strips to register with the lines and headings upon the upper strip. This unequal feeding of the strips also causes the upper one to buckle or become loose, so that it does not lie flat upon the writing-tablet.

The object of my invention is to provide a convenient means to rapidly readjust the sheets without drawing them from the drawing-rolls. This object I accomplish by providing means to readily separate the feeding-rolls whenever it becomes desirable, and to quickly throw them to the working position when the strips are properly adjusted.

The invention will be first fully described in connection with the accompanying drawings, in which like parts are indicated by similar reference-letters wherever they occur throughout the various views, and will be particularly referred to, and pointed out in the claims.

Figure 1 is a perspective view of an automatic registering device of ordinary construction provided with my improvements. Fig. 2 is an elevation, upon a greatly enlarged scale, of that portion of the case side to which my improvements are applied. Fig. 3 is a view in vertical section taken through line

xx of Fig. 2. Fig. 4 is a perspective view of one of my roll-separating bearings.

In Fig. 1 I have shown a popular form of autographic registering device, which consists of a box or case composed of sides A, properly braced apart by cross-bars, which serve also as guides for the paper strips which are drawn from rolls journaled upon the shafts within the box, as shown in dotted line. These strips are passed through a slot in the top of the box and drawn over a writing-tablet B through rolls located under the housing C. One or more of these strips are passed by the drawing-rolls above the glass tablet or window D, while the lower strip is passed into the box below the window D, where it is filed and kept as a record not accessible to the salesman. These sales-tickets are severed after they have passed the drawing-rolls. This general description is sufficient to enable any one to understand the class of devices to which my invention is applicable; but if a more detailed description is required reference is made to Letters Patent No. 410,616, issued September 10, 1889, to John B. Thies.

I will now describe my invention as applied to this class of registers. The sides A are usually made of cast metal having perforated bosses a to furnish bearings for the journals of the lower or driving roll G, of the pair of drawing-rolls, the surfaces of which are preferably covered with rubber or other yielding substance. The boxes E, which carry the upper roll, are fitted to slide vertically in slots in the sides A. These boxes are bored out to receive the journal-bearings F, Fig. 4. These bearings are eccentrically bored to receive the journals of the upper drawing-roll G', and upon their outer ends are provided with levers f , by which the bearings F are turned one-half a revolution to separate the roll G' from the lower one G, so that the strips of paper may be drawn freely between the rolls to adjust them. When the strips are adjusted, the levers are turned in the opposite direction to bring the rolls in working position. Upon the outer ends of the boxes E are secured angle-plates e , to limit the motion of the levers and stop the eccentric sleeves or bearings F, when the upper roll is brought to

its upper or lower position. These plates also retain the eccentric-bearings in place and prevent end motion. The pressure of the rolls is regulated by set-screws H, which are
 5 tapped through the sides and bear upon the top of the boxes E. It should be understood that both sides of the device are alike.

As the essence of my invention is in means for separating the rolls in this class of devices, so as to admit of a ready adjustment
 10 of the paper strips without withdrawing them from between the rolls, it is obvious from the foregoing that many mere mechanical changes may be made in my device to accomplish the
 15 same end. I have shown what I believe to be the best means; but I would have it understood that I shall consider all mere mechanical variations as within the spirit and scope of my invention.

20 What I claim is—

1. In an autographic registering device of the character described, the combination of the case sides, supporting two or more paper-rolls, the writing-tablet B, over which the paper
 25 webs are drawn, the drawing-rolls G G', movable bearings for one of said rolls, and levers

to actuate said bearings for the purpose of separating and closing said rolls, substantially as and for the purpose described.

2. The combination, substantially as here- 30
 in before set forth, of the case sides A, supporting the paper-rolls, and drawing-roll G, mounted to revolve therein, the boxes E, fitted in the case sides, the eccentric-bearings F, fitted to turn in said boxes, the roll G, jour- 35
 naled in said bearings, and the levers *f*, by which the eccentric-bearings are turned for the purpose of separating or closing the drawing-rolls.

3. The combination of the stationary draw- 40
 ing-roll G, the movable drawing-roll G', the vertically-adjustable boxes E for the movable roll, the eccentric-bearings F, fitted to turn within said boxes, the levers *f* for turning said bearings, and the angle-plates *e*, to hold 45
 the bearings in place and stop the levers when turned in either direction.

JOHN E. PEIRCE.

Witnesses:

C. E. MINNIGH,
 H. E. PARROTT.