



INTERNATIONAL APPLICATION PUBLISHED UNDER THE PATENT COOPERATION TREATY (PCT)

<p>(51) International Patent Classification ⁷ : A61M 37/00</p>	<p>A1</p>	<p>(11) International Publication Number: WO 00/35530 (43) International Publication Date: 22 June 2000 (22.06.00)</p>
--	------------------	--

<p>(21) International Application Number: PCT/US99/29925 (22) International Filing Date: 15 December 1999 (15.12.99) (30) Priority Data: 60/112,691 18 December 1998 (18.12.98) US 09/460,121 13 December 1999 (13.12.99) US (71) Applicant: MINIMED INC. [US/US]; 12744 San Fernando Road, Sylmar, CA 91342 (US). (72) Inventors: MCCONNELL, Susan, M.; 4635 Gershwin Place, Woodland Hills, CA 91364 (US). LORD, Peter, C.; 25505 Old Course Way, Valencia, CA 91355 (US). LIVINGSTON, John, H.; 31 Augusta Lane, Newport Beach, CA 92660 (US). KOVELMAN, Paul, H.; 5344 Seneca Place, Simi Valley, CA 93063 (US). (74) Agent: KOVELMAN, Paul, H.; MiniMed, Inc., 12744 San Fernando Road, Sylmar, CA 91342 (US).</p>	<p>(81) Designated States: AL, AM, AT, AU, AZ, BA, BB, BG, BR, BY, CA, CH, CN, CU, CZ, DE, DK, EE, ES, FI, GB, GD, GE, GH, GM, HR, HU, ID, IL, IN, IS, JP, KE, KG, KP, KR, KZ, LC, LK, LR, LS, LT, LU, LV, MD, MG, MK, MN, MW, MX, NO, NZ, PL, PT, RO, RU, SD, SE, SG, SI, SK, SL, TJ, TM, TR, TT, UA, UG, UZ, VN, YU, ZW, ARIPO patent (GH, GM, KE, LS, MW, SD, SL, SZ, TZ, UG, ZW), Eurasian patent (AM, AZ, BY, KG, KZ, MD, RU, TJ, TM), European patent (AT, BE, CH, CY, DE, DK, ES, FI, FR, GB, GR, IE, IT, LU, MC, NL, PT, SE), OAPI patent (BF, BJ, CF, CG, CI, CM, GA, GN, GW, ML, MR, NE, SN, TD, TG).</p> <p>Published <i>With international search report. Before the expiration of the time limit for amending the claims and to be republished in the event of the receipt of amendments.</i></p>
---	---

(54) Title: INSERTION SETS WITH MICRO-PIERCING MEMBERS FOR USE WITH MEDICAL DEVICES AND METHODS OF USING THE SAME

(57) Abstract

An insertion set for essentially painless insertion through tissue includes a substrate and at least one micro-piercing member. The at least one micro-piercing member is coupled to the substrate to form a patch. In addition, the at least one micro-piercing member has a predetermined length to pierce the material to a predetermined depth to interact with the tissue. In particular embodiments, the insertion set also includes a control structure within the insertion set for controlling the flow of fluid relative to the substrate and the at least one micro-piercing member of the insertion set. In addition, the insertion set may include or utilize methods or structures for maintaining the insertion set on the tissue for a predetermined period of time. Preferably, the predetermined length of the at least one micro-piercing member is long enough to pierce the tissue, and yet short enough to avoid contacting the nerves in the tissue. The insertion set may also include a light controlling structure within the insertion set for controlling the entry of light relative to the substrate and the at least one micro-piercing member of the insertion set. Some types of insertion sets may include a fluorescent analyte detection compound (or other detection compound) to detect the level of an analyte in the tissue, while other insertion sets are an infusion set for infusing a liquid into the tissue.

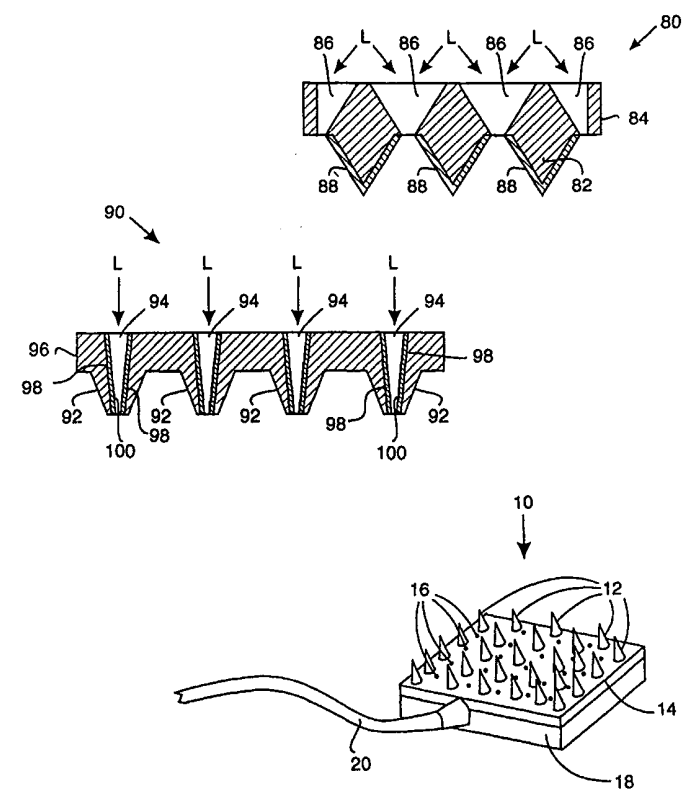

FOR THE PURPOSES OF INFORMATION ONLY

Codes used to identify States party to the PCT on the front pages of pamphlets publishing international applications under the PCT.

AL	Albania	ES	Spain	LS	Lesotho	SI	Slovenia
AM	Armenia	FI	Finland	LT	Lithuania	SK	Slovakia
AT	Austria	FR	France	LU	Luxembourg	SN	Senegal
AU	Australia	GA	Gabon	LV	Latvia	SZ	Swaziland
AZ	Azerbaijan	GB	United Kingdom	MC	Monaco	TD	Chad
BA	Bosnia and Herzegovina	GE	Georgia	MD	Republic of Moldova	TG	Togo
BB	Barbados	GH	Ghana	MG	Madagascar	TJ	Tajikistan
BE	Belgium	GN	Guinea	MK	The former Yugoslav Republic of Macedonia	TM	Turkmenistan
BF	Burkina Faso	GR	Greece			TR	Turkey
BG	Bulgaria	HU	Hungary	ML	Mali	TT	Trinidad and Tobago
BJ	Benin	IE	Ireland	MN	Mongolia	UA	Ukraine
BR	Brazil	IL	Israel	MR	Mauritania	UG	Uganda
BY	Belarus	IS	Iceland	MW	Malawi	US	United States of America
CA	Canada	IT	Italy	MX	Mexico	UZ	Uzbekistan
CF	Central African Republic	JP	Japan	NE	Niger	VN	Viet Nam
CG	Congo	KE	Kenya	NL	Netherlands	YU	Yugoslavia
CH	Switzerland	KG	Kyrgyzstan	NO	Norway	ZW	Zimbabwe
CI	Côte d'Ivoire	KP	Democratic People's Republic of Korea	NZ	New Zealand		
CM	Cameroon			PL	Poland		
CN	China	KR	Republic of Korea	PT	Portugal		
CU	Cuba	KZ	Kazakistan	RO	Romania		
CZ	Czech Republic	LC	Saint Lucia	RU	Russian Federation		
DE	Germany	LI	Liechtenstein	SD	Sudan		
DK	Denmark	LK	Sri Lanka	SE	Sweden		
EE	Estonia	LR	Liberia	SG	Singapore		

TITLE

INSERTION SETS WITH MICRO-PIERCING MEMBERS FOR USE WITH MEDICAL DEVICES
AND METHODS OF USING THE SAME

5

RELATED APPLICATIONS:

This application claims priority on U.S. provisional application Serial No.
60/112,691 filed December 18, 1998, and entitled "Insertion Sets With Micro-
Needles And Methods Of Using The Same", which is here specifically
10 incorporated by reference.

FIELD OF THE INVENTION

This invention relates to insertion sets for use with medical devices and,
in particular embodiments, to insertion sets that use micro-piercing members for
15 use with infusion pumps, test apparatuses, drug delivery systems and/or sensors.

BACKGROUND OF THE INVENTION

Traditionally, medications have been delivered by injection with a single,
fine gauge needle or through an intravenous infusion set with a catheter.
20 However, the administration of an injection with a needle or an intravenous
infusion through a catheter is often accompanied by a small amount of pain or
discomfort as the needle or catheter is inserted and withdrawn from the injection
or infusion site. This often acts as a deterrent to compliance with a medical
regimen as patients seek to avoid the pain or discomfort. To overcome this
25 drawback, finer needles or catheters have been used. However, the finer needles
and catheters still irritate the skin and associated nerve endings, causing some
discomfort and pain, and deterring patient compliance.

As an alternative to overcome these drawbacks, drug delivery systems
have been developed that deliver the medication by infusion into subcutaneous
30 tissue using an infusion set with a soft cannula. However, the soft cannula of the
infusion set is still inserted into the skin with a needle to prevent kinking of the

soft cannula. This, while less traumatic than some other injections, still causes some, although small, discomfort and irritation from the insertion and removal of the needle. One attempt to greatly reduce discomfort and pain has involved the use of automatic insertion devices. But there is still the possibility of some minor
5 irritation since the needle and soft cannula can contact nerves in the subcutaneous tissue.

Another alternative to overcome some of these drawbacks has been the use of transdermal patches to transfer medications through the skin. This method avoids piercing the skin. However, this method of introducing medication
10 through the skin is very limited, since only a few medications are easily passed through the outer skin layers and most will not be passed through the skin surface in sufficient volumes or rates without piercing the skin.

To overcome this drawback of slow medication transfer, silicon micro-needles have been proposed that would pierce the skin to a very minor depth at a
15 distance that does not contact nerve cells and avoids any introduction of pain. However, although this experimental technique is promising there has been no practical application proposed to deliver the medication through these solid micro-needles. One example of typical silicon micro-needles is shown in Fig. 1, and described in "Break Throughs - Technology - Microneedles", Discover
20 magazine, October 1998 (pages 22 and 23), and "Microfabricated Microneedles: A Novel Approach to Transdermal Drug Delivery", Journal of Pharmaceutical Sciences, Volume 87, Number 8, August 1998 (Pages 922-925), which are attached hereto as part of this specification and incorporated by reference.

In other medical devices, bodily characteristics are determined by
25 obtaining a sample of bodily fluid. For example, diabetics often test for blood glucose levels. Traditional blood glucose determinations have utilized a painful finger prick using a lancet to withdraw a small blood sample. This results in discomfort from the lancet as it contacts nerves in the subcutaneous tissue. The pain of lancing and the cumulative discomfort from multiple needle pricks is a
30 strong reason why patients fail to comply with a medical testing regimen.

Although non-invasive systems have been proposed, or are in development, none to date have been commercialized, which are effective and provide accurate results.

5 SUMMARY OF THE DISCLOSURE

It is an object of an embodiment of the present invention to provide an improved insertion set, which obviates for practical purposes, the above mentioned limitations.

10 In accordance with an embodiment of the present invention, an insertion set for essentially painless insertion through tissue of a patient includes a substrate, a plurality of micro-piercing members and a control structure. The plurality of micro-piercing members are coupled to the substrate to form a patch. In addition, the micro-piercing members have a predetermined length to pierce the tissue to a predetermined depth to interact with the tissue of the patient. The control structure is within the insertion set for directing and controlling the flow of fluid relative to the substrate and the plurality of micro-piercing members of the insertion set. In addition, the insertion set may include or utilize methods or structures for maintaining the insertion set on the tissue for a predetermined period of time. Preferably, the predetermined length of the at least one micro-piercing member is long enough to pierce the tissue, and yet short enough to avoid contacting the nerves in the tissue. Still further embodiments of the present invention include a light controlling structure within the insertion set for controlling the entry of light relative to the substrate and the at least one micro-piercing member of the insertion set. Some embodiments include a fluorescent analyte detection compound (or other detection compound) to detect the level of an analyte in the tissue, while other embodiments of the insertion set are an infusion set for infusing a liquid into the tissue. Other embodiments of an insertion set are a combination of an infusion set and a sensor set to perform both functions.

30 In a further embodiment of the present invention, an insertion set for

essentially painless insertion through tissue of a patient includes a substrate, a plurality of micro-piercing members, and a light controlling structure. The plurality of micro-piercing members are coupled to the substrate to form a patch. In addition, the micro-piercing members have a predetermined length to pierce
5 the tissue to a predetermined depth to interact with the tissue of the patient. The light controlling structure is within the insertion set for controlling the entry of light relative to the substrate and the plurality of micro-piercing members of the insertion set. In addition, the insertion set may include or utilize methods or structures for maintaining the insertion set on the tissue for a predetermined
10 period of time. Preferably, the predetermined length of the at least one micro-piercing member is long enough to pierce the tissue, and yet short enough to avoid contacting the nerves in the tissue. Still further embodiments of the present invention include a light controlling structure within the insertion set for controlling the entry of light relative to the substrate and the at least one micro-
15 piercing member of the insertion set. Some embodiments include a fluorescent analyte detection compound (or other detection compound) to detect the level of an analyte in the tissue, while other embodiments of the insertion set are an infusion set for infusing a liquid into the tissue. Other embodiments of an insertion set are a combination of an infusion set and a sensor set to perform both
20 functions.

According to another embodiment of the invention, an insertion set for insertion through a material includes a substrate and at least one micro-piercing member. The at least one micro-piercing member is coupled to the substrate to form a patch. In addition, the at least one micro-piercing member has a
25 predetermined length to pierce the material to a predetermined depth to interact with the material. In particular embodiments, the insertion set also includes a control structure within the insertion set for controlling the flow of fluid relative to the substrate and the at least one micro-piercing member of the insertion set. In addition, the insertion set may include or utilize methods or structures for
30 maintaining the insertion set on the material for a predetermined period of time.

Preferably, the predetermined length of the at least one micro-piercing member is long enough to pierce the material, and yet short enough to avoid contacting contact sensitive elements in the material. Still further embodiments of the present invention include a light controlling structure within the insertion set for
5 controlling the entry of light relative to the substrate and the at least one micro-piercing member of the insertion set. Some embodiments include a fluorescent analyte detection compound (or other detection compound) to detect the level of an analyte in the material, while other embodiments of the insertion set are an infusion set for infusing a liquid into the material. Other embodiments of an
10 insertion set are a combination of an infusion set and a sensor set to perform both functions.

In another further embodiment of the present invention, a self-lancing test strip for essentially painless analysis of an analyte in the tissue of a patient includes a substrate, a plurality of micro-piercing members, a control structure,
15 and an analyte strip. The plurality of micro-piercing members are coupled to the substrate to form a patch. In addition, the micro-piercing members have a predetermined length to pierce the tissue to a predetermined depth to interact with the tissue of the patient. The control structure is within the insertion set for controlling the flow of fluid relative to the substrate and the plurality of micro-
20 piercing members of the insertion set. Also, the analyte strip is coupled to the substrate to receive fluid from the control structure of the insertion set. In further embodiments, the insertion set may include or utilize methods or structures for maintaining the insertion set on the tissue for a predetermined period of time. Preferably, the predetermined length of the at least one micro-piercing member is
25 long enough to pierce the tissue, and yet short enough to avoid contacting the nerves in the tissue. Some embodiments include a fluorescent analyte detection compound (or other detection compound) to detect the level of an analyte in the tissue. Other embodiments of an insertion set are a combination of an infusion set and a sensor set to perform both functions.

30 Other features and advantages of the invention will become apparent from

the following detailed description, taken in conjunction with the accompanying drawings which illustrate, by way of example, various features of embodiments of the invention.

5 BRIEF DESCRIPTION OF THE DRAWINGS

A detailed description of embodiments of the invention will be made with reference to the accompanying drawings, wherein like numerals designate corresponding parts in the several figures.

10 Fig. 1 is a perspective view of silicon micro-needles of the type that may be used in embodiments of the present invention.

Fig. 2 is a perspective view of an insertion set in accordance with a first embodiment of the present invention.

Fig. 3 is a perspective view of an insertion set in accordance with a second embodiment of the present invention.

15 Fig. 4 is a cross-sectional view of the insertion set as shown along the line 4-4 in Fig. 3.

Fig. 5 is a cross-sectional view of the insertion set shown in Fig. 3 and an encapsulating covering to secure the insertion set to the skin.

20 Fig. 6 is a cross-sectional view of an insertion set in accordance with a third embodiment of the present invention.

Fig. 7a is a cross-sectional view of an insertion set in accordance with a fourth embodiment of the present invention.

Fig. 7b is an enlarged, partial cross-sectional view of the insertion set as shown in the circle 7b of Fig. 7a.

25 Fig. 8 is a cross-sectional view of an insertion set in accordance with a fifth embodiment of the present invention.

Fig. 9 is a cross-sectional view of an insertion set in accordance with a sixth embodiment of the present invention.

30 Fig. 10 is a cross-sectional view of an insertion set in accordance with a seventh embodiment of the present invention.

Fig. 11 is a perspective view of a test strip in accordance with an eighth embodiment of the present invention.

Fig. 12A is a cross-sectional view of the test strip as shown along line 12-12 in Fig. 11.

5 Fig. 12B is a cross-sectional view of an alternative embodiment of the test strip shown in Fig. 12A.

Figs 13a and 13b are top plan views of an insertion sets in accordance with an embodiment of the present invention that are combinations infusion and sensor sets.

10 Fig. 14 is a cross-sectional view of an insertion set in accordance with another embodiment of the present invention.

Fig. 15 is a cross-sectional view of an insertion set in accordance with a further embodiment of the present invention.

15 Fig. 16 is a cross-sectional view of an insertion set in accordance with a still further embodiment of the present invention.

Fig. 17 is a partial bottom plan view of a capillary structure for a layer in the insertion set shown in Fig. 16.

Fig. 18(a) is a perspective view of an open encapsulating test strip in accordance with an additional embodiment of the present invention.

20 Fig. 18(b) is a perspective view of a closed encapsulating test strip in accordance with the embodiment of Fig. 18(a).

Fig. 19 is a cross-sectional view of an insertion set in accordance with yet another embodiment of the present invention.

25 Fig. 20 is a cross-sectional view of an insertion set in accordance with still yet another embodiment of the present invention.

Fig. 21 is a perspective view of a flexible insertion set in accordance with a further embodiment of the present invention.

DETAILED DESCRIPTION OF THE PREFERRED EMBODIMENTS

30 As shown in the drawings for purposes of illustration, the invention is

embodied in an insertion set such as an infusion set, sensor set, medical device, combination devices, or the like, with micro-piercing members. Further embodiments of the insertion sets or medical devices may utilize biodegradable implants, capsules, impregnated threads (with medications or the like) with the micro-piercing members. In addition, the insertion sets may be coated with medications, or other agents, that inhibit infection and/or promote healing of the insertion site. Preferred embodiments of the insertion sets are for transcutaneous placement of the insertion set in subcutaneous tissue just below the stratum corneum, but above the level where nerves are present. However, in alternative embodiments, the insertion set may be inserted to deeper depths in the subcutaneous tissue or into other subdermal tissues where the use of micro-piercing members is advantageous. In addition, still further embodiments may be used to place the insertion sets in other types of tissue, such as muscle, lymph, organ tissue or the like, and used in animal tissue. The embodiments may also be used in other applications to sample other fluid flows, such as manufacturing, semiconductor fabrication, chemical synthesis, or the like. Further embodiments of the invention are for infusion fluids other than medications, such as vitamins, hormones, drugs, proteins, peptides, suspensions, emulsions, gels, saline or the like.

In preferred embodiments, the insertion sets include at least one micro-piercing member attached to a substrate to pierce the tissue during insertion. In particular embodiments, the micro-piercing member is a micro-metal needle. In alternative embodiments, the micro-needle may be hollow, solid, grooved, or the like. In further alternative embodiments, the micro-piercing member may be made out of other materials, such as ceramic, plastic, etched metals, crystals embedded on a surface, fibers (such as glass or carbon), ceramics, glass, composites, silicon, biodegradable, hydrophilic substances, substances that soften and/or change once in contact with the body and/or bodily fluids, or the like. In other alternative embodiments, the insertion sets may include more than one micro-piercing member. For example, a single insertion set may include a micro-

5 piercing member for an infusion portion and another micro-piercing member for a separate sensor portion, or the like. Alternatively, the insertion sets may include a plurality of micro-piercing members on a small patch or substrate, such as a series of hollow (or grooved) micro-needles (such as from silicon, plastics, metal or the like) for infusion of a medication or a series of solid micro-needles for sensor applications (such as from silicon, plastics, metal or the like), which micro-needles are used to penetrate the skin. Preferred embodiments of the micro-piercing member have a length on the order of 100 μm . However, longer lengths such as 200 μm or shorter lengths such as 50 μm may be used. Other lengths may also be used, with the selection being dependent on the type of tissue to be penetrated, the depth of nerve tissue, condition of the patient, type of medication, the type of body characteristic to be determined, number of micro-piercing members, the size of the insertion set, or the like. The above features may be combined in various configurations to achieve a set with desired characteristics.

15 In particular embodiments, the micro-piercing members (or needles) have a circular cross-section. However, in alternative embodiments, the micro-piercing members may have other cross-sections, such as square, rectangular, triangular, polygonal, oval, ellipsoid or the like. In preferred embodiments, a substrate and micro-piercing members form a rectangular patch. However, in alternative embodiments, the substrate and micro-piercing members form different shape patches, such as square, triangular, polygonal, oval ellipsoid, or the like. Advantages to the use of micro-piercing members and a substrate structure include a larger surface area for infusion, fluid collection and/or sensing a characteristic, painless insertion, and extremely low profile. The above features may be combined in various configurations to achieve a set with desired characteristics.

25 Preferably, the substrate structure forming the patch is sized between 1/8" to 1/16" square. However, in alternative embodiments, the substrate structure forming the patch is sized smaller or can be considerably larger (upwards of several inches square) with the selection of size being dependent on the type of

30

medication to be infused, the characteristic to be determined, the patient condition, the amount of time the insertion set is to remain in position, and/or the like. For instance as shown, but not limited to, in Figs. 13a and 13b, an insertion set 140 or 142 includes a rigid or flexible substrate 144 that holds at least one
5 sensor 146 to determine a characteristic and at least one infuser 148 to infuse a liquid. If the substrate 144 is rigid, the insertion set 140 and 142 are worn most effective on large surface areas, such as the abdomen, back or the like. If the substrate 144 is flexible, the insertion set could be worn around a wrist, arm, leg or the like. In particular embodiments, the sensor 146 and the infuser are
10 separated by several inches if medication is being infused. However, if a calibration fluid is being infused to calibrate the sensor 146, the infuser 148 may be adjacent, combined with, or relatively close to the sensor 146. In another embodiment, as shown in Fig. 21, a plurality of micro-needle patches 147, that are generally rigid, are placed on a larger contoured and/or flexible patch 149 to
15 provide large surface areas for detection and/or infusion of fluids.

In particular embodiments, the insertion set is maintained in position at the insertion site on the tissue with an adhesive overdressing. In other embodiments, an adhesive patch (or under-dressing) is placed on the tissue prior to insertion of the insertion set, or is used in addition to an overdressing. In still
20 other embodiments, the insertion set has wings (or a flange) surrounding the periphery of the insertion set, which have an adhesive that attaches the insertion set to the tissue. This can be augmented by an overdressing and/or an under-dressing. In yet other embodiments, the substrate surface between the micro-piercing members may have an adhesive that attaches the insertion set to the
25 tissue. This can also be augmented by wings (or a flange), an overdressing and/or an under-dressing. In alternative embodiments, the insertion set may also be attached by sutures, staples, clamps, glue, or the like. In particular embodiments, the micro-piercing members are coated with an anti-microbial substance that tends to inhibit infection occurring around the perforation made in the skin.
30 Further embodiments include a healing agent, such as Vitamin E, anti-

inflammatory agents, such as Dexamethasone, or the like, that promotes healing and/or minimizes scarring after removal of the insertion set with the micro-needles.

As discussed above, preferably, silicon is used to form the micro-piercing members (or needles) and substrates. The micro-piercing members and substrate structure can be formed in silicon through the use of silicon wafer technology such as photolithography, chemical etching, vapor deposition, DREI, laser drilling, and/or the like. In alternative embodiments, metals, ceramics, plastics, or the like, are used to form the micro-piercing members and substrate structure. Such materials include, but are not limited to, specially engineered polymer materials designed for deep photo etching using MEMS (Micro Electro Mechanical Systems) processing techniques, or the like. Methods which can be used for creating the structure in ceramics, metal, or plastic include molding, thermoforming, laser drilling, chemical etching and/or the like. Plastics that can be used for the micro-piercing members and substrate structure include, but are not limited to, PEEK (polyetheretherketone) and LCP (Liquid Crystal Polymer), polycarbonates or the like. PEEK and LCP are particularly strong when formed with thin cross-sections and lend themselves to conventional molding techniques. Plastics may be molded (depending on their flow characteristics) or more viscous plastics could require a combination of molding and laser drilling/chemical etching or thermoforming with laser drilling/chemical etching. LCP is a unique plastic that has both amorphous and crystalline segments that form the plastic. The micro-piercing members and substrate could be formed in such a way that the crystalline segments line up in a particular direction. Then, the amorphous segment may be removed using chemical etching leaving the segments (rods, needles or micro-piercing members) of crystalline material exposed. This could also be done in glass filled plastics. In preferred embodiments, the micro-piercing members and the substrate are formed from the same material, either as an integral unit or separately and later connected. However, in alternative embodiments, the micro-piercing members and the substrate may be formed from

different materials.

In particular embodiments that are either formed from a single piece of material or formed from multiple materials, it is advisable to coat the substrate and micro-piercing members with a material that helps maintain the structural integrity of the insertion set and minimizes breakage, fracture and/or loss of micro-piercing members once the insertion set is inserted or during withdrawal of the insertion set. For instance, the insertion set and micro-piercing members could be coated with a thin layer (i.e., a few microns) of parylene, plastic or the like.

In particular embodiments, the micro-piercing members and substrate structure are generally optically opaque to light and electromagnetic radiation. In other embodiments, the micro-piercing members and substrate structure may have transmissions in ranges or bands for particular purposes, or may be optically transparent to light and electromagnetic radiation that enable the insertion sets to be used as described in more detail below. In other embodiments, as shown in Fig. 14, the insertion set 150 may include "rods" or light pipes 152 that are included in the substrate 154 to direct light to the piercing members 156. In preferred embodiments, the light pipes 152 are formed as separate elements out of SiO₂, Al₂O₃, glass, plastic, or the like, and are connected to the substrate 154 by the use of anodic bonding. In alternative embodiments, the piercing members 156 are formed as the light pipes 152. In addition, the insertion set may be formed from a single piece of SiO₂, Al₂O₃, glass, plastic, or the like, and are etched to form the substrate and micro-piercing members.

In preferred embodiments, the micro-piercing members (or needles) are solid, and access to the insertion site openings, formed by penetration of the micro-piercing members, is through holes drilled in the supporting substrate of the micro-piercing members. Fluids can be drawn out of these holes by capillary action or active suction. Fluids can also be introduced to the insertion site by pumping or capillary action that is biased to flow medication through the holes and through the insertion openings formed by penetration of the micro-piercing

members. In alternative embodiments, the micro-piercing members (or needles) are hollow and permit fluid to be withdrawn or provided to the openings formed by the micro-piercing members at the insertion site through the interior of the micro-piercing members. In further alternatives, the holes may be formed in a part of the micro-piercing members (i.e., on one side of the member - rather than through the exact center) and a part of the substrate. This would simplify manufacturing and avoid very thin tips that might break off when a hole is formed through the exact center of the micro-piercing member. In other embodiments, the use of holes may be avoided by the use of porous materials such as porous sintered titanium, porous polyethylene or other such materials. This would permit medications or other fluids to permeate through the substrate to the tissue or from the tissue to the back of the insertion set. It could also simplify manufacturing issues associated with forming holes in either the micro-piercing members and/or the substrate.

As illustrated in Fig. 2, an insertion set 10 is formed by a plurality of solid micro-piercing members 12 (or needles) attached to a substrate 14. In preferred embodiments, the micro-piercing members 12 are formed integral with the substrate 14 or formed separately and attached to the substrate 14. The substrate 14 is formed with holes 16, or the holes 16 are drilled, adjacent the micro-piercing members 12. The back of the substrate 14 is covered by a fluid delivery chamber 18, which is in turn coupled to an infusion supply tube 20. Medication is then pumped to the medication chamber 18 and dispersed out the holes 16 in the substrate 14 to permeate into the openings formed in the tissue by the penetration of the micro-piercing members 12 in the tissue. In alternative embodiments, the insertion set 10 may be utilized with a sensor and characteristic monitor, in which fluid is drawn off and supplied to the sensor.

Figs. 3 and 4 illustrate an insertion set 30 in accordance with a second embodiment of the present invention that includes an array of micro-piercing members 32 (or needles) formed on a substrate 34. The micro-piercing members 32 are formed with holes 36 passing through the micro-piercing members and the

substrate. For example, silicon could be used as the materials, and the micro-piercing members 32 and substrate 34 structure are perforated. Next a fluid flow connector 38 is attached to the back 40 of the substrate 34 structure. The fluid flow connector 38 is attached to infusion tubing 42 which is attachable to a pump (not shown) to provide fluid communication with the holes 36. The holes 36 do not need to precisely exit the tip 44 (or ends) of the micro-piercing members 32. In fact, it may be advantages to have the holes 36 slightly offset to produce “half needles” or the like with deeper penetration, and which then have the medication flow down the sides of the micro-piercing members 32 into the tissue. In alternative embodiments, the insertion set 30 may be utilized with a sensor and characteristic monitor, in which fluid is drawn off and supplied to the sensor.

Fig. 5 illustrates an alternative embodiment that uses the insertion set 30 shown in Figs. 3 and 4 without the infusion tubing 42 and/or fluid flow connector 40 or the insertion set 10 shown in Fig. 2. The insertion set 30 containing the micro-piercing members 32 and the substrate 34 structure is encapsulated in an encapsulation material 50 and secured to the tissue by an adhesive 50. The encapsulation material 50 may be coupled to infusion tubing 42 and an infusion pump (not shown). In particular embodiments, the encapsulation material 50 can form a pressurized reservoir 54 that contains medication, or other fluid, that is slowly infused into the tissue through the openings in the substrate structure. Preferably, the medication, or other fluid, is loaded into the reservoir 54 after insertion of the insertion set to minimize issues of leakage during assembly, storage and transport. In alternative embodiments, the encapsulation material 50 may be a component of an infusion pump that pumps the medication, or other fluid, into the user, such as a wrist watch device, or the like mounted over the encapsulation material 50. In other embodiments, the encapsulation material 50 may form a negative pressure reservoir to draw off fluid from the tissue. In other embodiments, a suction device (not shown) may be attached to the encapsulation material 50, where for example, a user uses a valve structure to vent air and then apply suction to the interior of the encapsulation material 50 forming the reservoir

54 to draw off the fluid. The drawn off fluid could be used to determine bodily characteristics with a built in sensor or drawn off fluid could be supplied to a remote sensor. Preferably, the negative pressure is created in the reservoir 54 after insertion of the insertion set to minimize issues of leakage during assembly, storage and transport. In alternative embodiments, the encapsulation material 50 may contain hydrophilic or wicking material (instead of or in addition to the negative pressure) to draw off fluid from the tissue. In further embodiments, the encapsulation material 50 may be divided into sub-regions, in which one region provides fluid to the tissue and the other region withdraws fluid from the tissue. In still further embodiments, the encapsulation material 50 may be used with ionphoretic medication devices or the like. For example, these types of devices would work more efficiently, since the outer layer of the tissue is already penetrated and fluid flow is easier to facilitate.

As discussed above, embodiments of the insertion sets can be created in chemically etched metals, such as titanium or stainless steel. Also, high strength plastics or composite structures can be used. For example, as shown in Fig. 6, an insertion set 60 in accordance with third embodiment of the present invention utilizes hollow carbon or glass fibers that form the micro-piercing members 62 (or needles). The micro-piercing members 62 are imbedded in another matrix material to form the substrate 64 to create the insertion set 60. In one embodiment, LCP plastic (described above) is a good candidate for forming an insertion set 60 having this structure. In alternative embodiments, ceramics or sintered metals are also suitable for forming the insertion set 60.

Figs. 7a and 7b illustrate an insertion set 70 in accordance with a fourth embodiment of the present invention. The insertion set 70 includes micro-piercing members 72 (or needles) that have an outer surface 74 coated with a photo-reactive substance or compound 76 that optically changes, fluoresces, or the like, or other suitable compounds that detect changing properties in the presence of a bodily fluid analyte, such as glucose or the like. The compounds can also be used to detect the level of an analyte that has been ingested, injected

or placed inside the body, such as marker substances, or the like. For example, possible compounds, including but not limited to, produce a fluorescent change in the presence of a bodily fluid analyte are disclosed in U.S. Patent No. 5,503,770 issued April 2, 1996 to James et al. and entitled "Fluorescent Compound Suitable
5 For Use In The Detection Of Saccharides"; U.S. Patent No. 5,512,246 issued April 30, 1996 to Russell et al. and entitled "Method and Means for Detecting Polyhydroxyl Compunds"; U.S. Provisional Application Serial No. 60/007,515 to Van Antwerp et al. and entitled "Minimally Invasive Chemically Amplified Optical Glucose Sensor"; and U.S. Patent Application Serial No. 08/752,945 to
10 Van Antwerp et al. and entitled "Detection of Biological Molecules Using Chemical Amplification", all of which are herein incorporated by reference. Other compounds using Donor Acceptor fluorescent techniques may be used, such as disclosed in U.S. Patent No. 5,628,310 issued May 13, 1997 to Rao et al. and entitled " Method and Apparatus to Perform Trans-cutaneous Analyte
15 Monitoring"; U.S. Patent No. 5,342,789 issued August 30, 1994 to Chick et al. and entitled "Method and Device for Detecting and Quantifying Glucose in body Fluids"; and U.S. Patent No. 5,246,867 issued September 21, 1993 to Lakowicz et al. and entitled "Determination and Quantification of Saccharides by Luminescent Lifetimes and Energy Transfer", all of which are herein incorporated
20 by reference.

In the illustrated embodiment, the micro-piercing members 72 are coated with the fluorescent material 76 and a substrate 78 is drilled with holes 79 that permit the passage of light L to illuminate the sides of the micro-piercing members 72 to induce a fluorescent reaction in the coated material 76 in the
25 presence of the analyte. The strength (or intensity) of the florescence from the coated material is used to determine the amount of analyte present in the bodily fluid (such as interstitial fluid, blood or the like). In alternative embodiments, lifetime measurements of the fluorescence may be used. The use of exterior coated micro-piercing members 72 is preferred for near continuous monitoring
30 applications, since it is easier for bodily fluids to flow around and be replenished

around the outside of the micro-piercing members 72. In other embodiments, a second fluorescent compound (not shown) is used as a reference signal and may be placed at one or more locations around the substrate 78. Still further embodiments, may be utilized with an infusion set to determine the level of medication, or fluid being absorbed to determine proper flow rates.

As discussed, preferred embodiments utilize fluorescent compounds to determine a bodily characteristic. However, alternative embodiments may use other electro-chemical reactions, such as, for example, in diabetes testing, the compounds could be those currently used in conventional blood glucose meters or glucose sensors that use interstitial fluid with glucose oxidase sensors such as those disclosed in U.S. Patent No. 5,391,250 issued February 21, 1995 to Cheney, II et al. and entitled "Method of Fabricating Thin Film Sensors", which is herein incorporated by reference. Other compounds for the detection of viral loads (such as in HIV, hepatitis or the like), cholesterol levels, or other analytes may also be used. In addition, optical analyte materials that measure a change in optical properties of the materials that are sensitive to IR, visible or other forms of radiation may be used.

Fig. 8 illustrates an insertion set 80 in accordance with a fifth embodiment of the present invention. The insertion set 80 contains a plurality of coated micro-piercing members 82 (or needles) on a substrate 84 similar to that shown in Figs. 7a and 7b. However, in this embodiment, the holes 86 in the substrate 84 are more conical to allow better illumination of the sides of the coated micro-piercing members 82. A preferred method for forming conical holes 86 is the use of back side etching of the substrate 84, which would be easier than laser drilling. This allows the light L to more directly impinge on the fluorescent compound 88 (or other suitable detection compound), and minimizes reliance on reflection off the tissue. In alternative embodiments, the holes may be cylindrical, like in the earlier embodiments, but formed at an angle to illuminate one side of the micro-piercing members 82. This simplifies manufacturing of the substrate 84, since more conventional manufacturing methods, such as laser drilling may be used.

In another alternative embodiment, the substrate 84 and/or micro-piercing members 82 are formed from optically transparent materials that permit the light to pass through the substrate 84 and the micro-piercing members 82 to illuminate the fluorescent compound (or other suitable detection compound). This would be advantageous, since it would obviate the need to drill light transmitting holes. It would also possibly be more acceptable for continuous sensing, since the holes would not be come clogged with bodily fluids and the fluid around the micro-piercing members 82 would not tend to easily "dry out." As shown in Fig. 15, an insertion set 160 is formed without holes in the substrate and/or through the micro-piercing members 164. The substrate 162 and micro-piercing members 164 are formed from a transparent material, such as SiO₂, Al₂O₃, glass, plastic, or the like, to permit light L to pass through to the substrate 162 and micro-piercing members 164 to a coating 166, similar to that described above in the embodiments of Figs. 7a-8.

Fig. 9 illustrates an insertion set 90 in accordance with a sixth embodiment of the present invention, in which the micro-piercing members 92 (or needles) are formed with the holes 94 passing through the micro-piercing members 92 and a substrate 96. In this embodiments, the interior surface 98 of the hollow micro-piercing members 92 is coated with a fluorescent compound 100 (or other suitable detection compound). This permits easier exposure of the fluorescent compound 100 to light L and minimizes the effects of insufficient illumination or distortion through the substrate 96. This embodiment tends to be more ideally suited for discrete measurements, since it would require ancillary structure to make the fluid flow from the tissue continuously over long periods of time. This embodiment (as well as the embodiments as shown in Figs. 7a-8), could also be used with a fluid delivery system and used to detect back flow of bodily fluids (such as interstitial fluids, blood, or the like), which would indicate a blockage in the infusion supply tubing, or a compound could be used to determine the presence of bacteria and infection developing under the insertion set 90. The coating compound could also be used to detect other contaminants in

the fluid flow stream from the infusion supply.

Fig. 10 illustrates an insertion set 110 in accordance with a seventh embodiment of the present invention. This embodiment utilizes micro-piercing members 112 and a substrate 114 similar to that shown in Fig. 2 (although this embodiment could easily utilize the hollow micro-piercing member structure shown in Fig. 3). In this embodiment, the micro-piercing members 112 penetrate the tissue, and then the holes 116 in the substrate 114 draw off the interstitial fluid (or other liquid or fluid) by capillary action to a layer of material 118 that contains a fluorescent compound, or the like (as discussed above) that responds to the presence of an analyte in the interstitial fluid (or other liquid or fluid). The layer of material 118 may use capillary action to distribute the interstitial fluid (or other liquid or fluid) throughout the layer of material 118. In operation, the interstitial fluid (or other liquid of fluid) is pulled from the site by capillary action and wets the fluorescent compound which is then analyzed by a sensor to determine the concentration of the analyte.

Figs. 11 and 12A illustrate a self-lancing test strip 120 in accordance with an eighth embodiment of the present invention. The self-lancing test strip 120 uses solid (or hollow) micro-piercing members 122 (or needles) and holes 123 on a substrate 124 coupled via an adhesive or wicking material 126 to an analyte strip 128 that contains a compound that reacts to the presence of an analyte in bodily fluid (such as interstitial fluid, blood or the like) withdrawn from the fluid. In further embodiments, the wicking material or adhesive layer 126 may be omitted and the substrate 124 would be directly coupled to the analyte strip 128. In particular embodiments, a fluorescent compound and detection method is used as described above. However, in alternative embodiments, other electro-chemical reactions, such as, for example, in diabetes testing the compounds could be those currently used in conventional blood glucose meters or glucose sensors that use interstitial fluid with glucose oxidase sensors such as those disclosed in U.S. Patent No. 5,391,250 issued February 21, 1995 to Cheney, II et al. and entitled "Method of Fabricating Thin Film Sensors", which is herein incorporated by

reference. Other compounds for the detection of viral loads (such as in HIV, hepatitis or the like), cholesterol levels, or other analytes may also be used.

Preferably, the self-lancing test strip harvests interstitial fluid painlessly from the skin for an intermittent reading of the analyte level as a replacement to conventional finger sticks used to determine glucose levels, cholesterol levels or the like. In the preferred illustrated embodiment, the user taps the self-lancing test strip 120 with the micro-piercing members 122 against the skin to pierce the upper layer and then the interstitial fluid is released from the skin and pulled by capillary action through the holes 123 in the substrate 124. Alternatively, a flexible dome 300 and vent hole 302 are positioned over the skin penetrating portion of the self-lancing test strip 120 to create a negative pressure on the side opposite the micro-piercing members 122 to assist in drawing fluids through the holes 123 in the substrate 124, as shown in Fig. 12B.

The self-lancing test strip remains on the skin for a period of time sufficient to withdraw the interstitial fluid, with the time being determined based upon the condition of the user's skin, the temperature, the environmental conditions surrounding the tissue, the type of fluid being withdrawn, the number of micro-piercing members 122, the number of holes 123, the size of the substrate 124, or the like. The interstitial fluid is drawn into the wicking and/or adhesive layer 126 to evenly wet the compound in the analyte strip 128 above it. The self-lancing test strip 120 is then inserted into a meter (not shown) for analyzing the interstitial fluid using conventional tests, or the fluorescent tests described above.

Alternatively, the self-lancing test strip 120 can be left in place on the skin (or tissue), and a test meter can be used to periodically measure the analyte, without the need to remove the self-lancing test strip from the skin.

Preferably, the analyte layer 128 is placed down on any optical device to minimize scratching or abrasion of the optical device by the micro-piercing members 122. In alternative embodiments, the micro-piercing members are hollow and draw the interstitial fluid to the reagent through the interior of the micro-piercing members. In further embodiments, the micro-piercing members

and substrate are formed out of a porous materials to facilitate transfer of the bodily fluid. This may obviate the need for holes in the substrate and/or micro-piercing members.

5 Figs. 16 and 17 illustrate a variation of the embodiments shown in Figs. 10-12, in which an insertion set 170 contains a layer of micro channels 172 between the substrate 174 and the analyte material 176. In preferred
10 embodiments, the micro-channels are “v” shaped and formed from etching of the material forming the layer of micro-channels. Also, as shown in Figs. 16 and 17, the holes 178 in the substrate 174 line up with the intersections 180 of the
15 channels 182 in a first direction and the channels 184 in a second direction. The channels may be at right angles, oblique, acute, or the like to each other. Preferably, the channels are etched to a few microns depth to promote capillary action to draw the fluid to a collection reservoir 186 that concentrates the
20 collected fluid to provide stronger readings. This allows fluid to be collected over a wide area in small quantities to give strong concentrated indications in a much smaller area. In alternative embodiments, the micro-channels may be formed on the opposite side of the substrate to improve the diffusion of the collected fluid in the analyte material. In further alternative embodiments, the micro-channels may be formed on both sides of the substrate.

25 Figs. 18(a) and 18(b) illustrate a self-lancing test strip 190 similar to the embodiment shown in Figs. 11, 12A and 12B. The embodiment includes a fold-over encapsulating tip 192 to cover the micro-piercing members 194 after use of the test strip 190. This avoids or minimizes the possibility of bio-hazard contamination after use of the test strip 190. In preferred embodiments, the fold-
30 over encapsulating tip includes an adhesive 196 and is folded over to cover the exposed micro-piercing members 194 after the test. In alternative embodiments, the fold-over tip, may be stiff enough to be bent away from the micro-piercing members 194 when the test strip 190 is used to avoid premature or accidental contact with the micro-piercing members 194. Then after use, the stiff fold-over tip springs back to cover the micro-piercing members 194. In further

embodiments, the interior surface of the fold-over tip that contacts the micro-piercing members 194 includes a reflective agent to improve the optical characteristics of the test strip 190, if a reading is taken from the opposite side.

Fig. 19 is a cross-sectional view of another insertion set 200 in accordance with an embodiment of the present invention. In this embodiment, the holes 202 (or channels) in the substrate 204 and/or micro-piercing members 206 are filled with a hydrophilic material 208 that draws out the fluid from beneath the skin. The hydrophilic material 208 facilitates getting the fluid more quickly and easily to an analyte detection compound 210. In addition, the hydrophilic material 208 tends to minimize the ability of the analyte detection compound to contact or migrate into the tissues of the user.

Fig. 20 is a cross-sectional diagram showing the use of an optically transparent substrate 212 and micro-piercing members 214 to permit light L to be introduced directly under the skin 215 to illuminate an implanted optical analyte material 216 to more easily determine the optical changes of the optical analyte material 216. The advantage is that the optical transparent substrate 212 and micro-piercing members 214 provide a shorter light path distance through the skin 215, which lowers the amount of total diffusion and absorption of light in the skin (or tissue).

While the description above refers to particular embodiments of the present invention, it will be understood that many modifications may be made without departing from the spirit thereof. The accompanying claims are intended to cover such modifications as would fall within the true scope and spirit of the present invention.

The presently disclosed embodiments are therefore to be considered in all respects as illustrative and not restrictive, the scope of the invention being indicated by the appended claims, rather than the foregoing description, and all changes which come within the meaning and range of equivalency of the claims are therefore intended to be embraced therein.

WHAT IS CLAIMED IS:

1. An insertion set for essentially painless insertion through tissue of a patient, the insertion set comprising:
 - a substrate:
 - 5 a plurality of micro-piercing members coupled to the substrate to form a patch, wherein the plurality of micro-piercing members have a predetermined length to pierce the tissue to a predetermined depth to interact with the tissue of the patient; and
 - 10 a control structure within the insertion set for controlling a flow of fluid relative to the substrate and the plurality of micro-piercing members of the insertion set.

2. An insertion set according to claim 1, further including means for maintaining the insertion set on the tissue for a predetermined period of time.

- 15 3. An insertion set according to claim 1, wherein the predetermined length of the plurality of micro-piercing members are long enough to pierce the tissue and short enough to avoid contacting the nerves in the tissue.

- 20 4. An insertion set according to claim 1, wherein the insertion set is an infusion set for infusing a liquid into the tissue.

5. An insertion set for essentially painless insertion through tissue of a patient, the insertion set comprising:

a substrate:

5 a plurality of micro-piercing members coupled to the substrate to form a patch, wherein the plurality of micro-piercing members have a predetermined length to pierce the tissue to a predetermined depth to interact with the tissue of the patient; and

10 a light controlling structure within the insertion set for controlling the entry of light relative to the substrate and the plurality of micro-piercing members of the insertion set.

6. An insertion set according to claim 5, further including means for maintaining the insertion set on the tissue for a predetermined period of time.

15 7. An insertion set according to claim 5, wherein the predetermined length of the plurality micro-piercing members are long enough to pierce the tissue and short enough to avoid contacting the nerves in the tissue.

20 8. An insertion set according to claim 7, wherein the insertion set further includes an optical analyte detection compound to detect the level of an analyte in the tissue.

9. An insertion set for insertion through a material, the insertion set comprising:

25 a substrate: and

at least one micro-piercing member coupled to the substrate to form a patch, wherein the at least one micro-piercing member has a predetermined length to pierce the material to a predetermined depth to interact with the material.

10. An insertion set according to claim 9, further including a control structure within the insertion set for controlling the flow of fluid relative to the substrate and the at least one micro-piercing member of the insertion set.

5 11. An insertion set according to claim 9, further including means for maintaining the insertion set on the material for a predetermined period of time.

10 12. An insertion set according to claim 9, wherein the predetermined length of the at least one micro-piercing member is long enough to pierce the material and short enough to avoid contacting contact sensitive elements in the material.

15 13. An insertion set according to claim 9, further including a light controlling structure within the insertion set for controlling the entry of light relative to the substrate and the at least one micro-piercing member of the insertion set.

20 14. An insertion set according to claim 13, wherein the insertion set further includes an optical analyte detection compound to detect the level of an analyte in the material.

25 15. An insertion set according to claim 9, wherein the insertion set further includes an analyte detection compound to detect the level of an analyte in the material.

16. An insertion set according to claim 9, wherein the insertion set is an infusion set for infusing a liquid into the tissue.

17. A self-lancing test strip for essentially painless analysis of an analyte in the tissue of a patient, the self-lancing test strip comprising:
a substrate:
a plurality of micro-piercing members coupled to the substrate to form a patch, wherein the plurality of micro-piercing members have a predetermined length to pierce the tissue to a predetermined depth to interact with the tissue of the patient;
a control structure within the insertion set for controlling a flow of fluid relative to the substrate and the plurality of micro-piercing members of the insertion set; and
an analyte strip coupled to the substrate to receive fluid from the control structure of the insertion set.
18. A self-lancing test strip set according to claim 17, wherein the analyte strip further includes a fluorescent analyte detection compound to detect the level of an analyte in the tissue.
19. A self-lancing test strip according to claim 17, wherein the analyte strip further includes an analyte detection compound to detect the level of an analyte in the tissue.
20. A self-lancing test strip according to claim 17, further including a light controlling structure within the insertion set for controlling the entry of light relative to the substrate and the at least one micro-piercing member of the insertion set.
21. A self-lancing test strip according to claim 20, wherein the analyte strip further includes an optical analyte detection compound to detect the level of an analyte in the tissue.

22. A self-lancing test strip according to claim 17, wherein the insertion set further includes an analyte detection compound to detect the level of an analyte in the tissue.

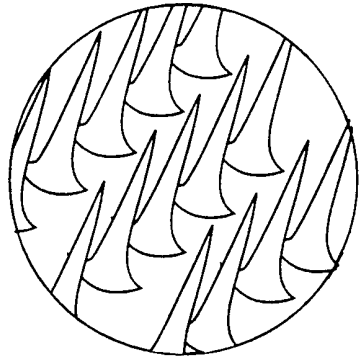

FIG. 1

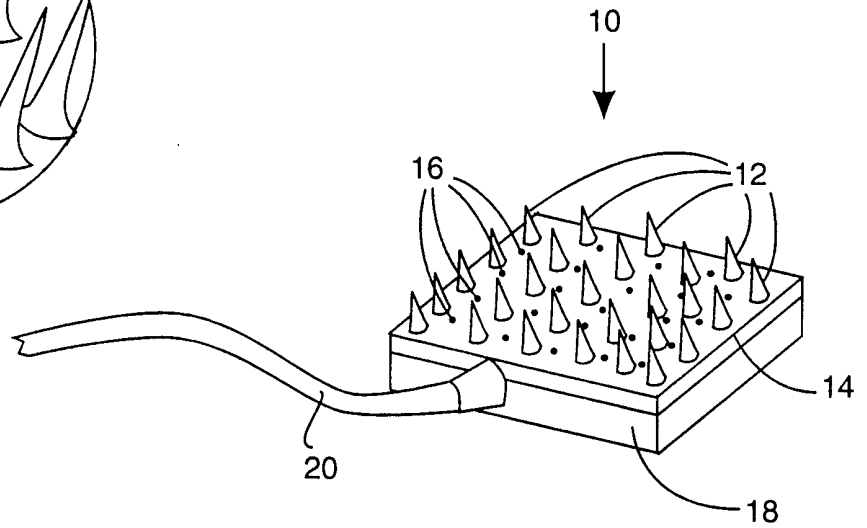

FIG. 2

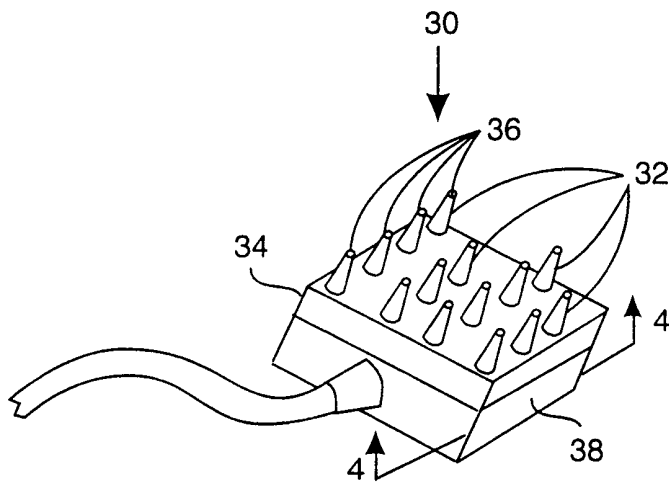

FIG. 3

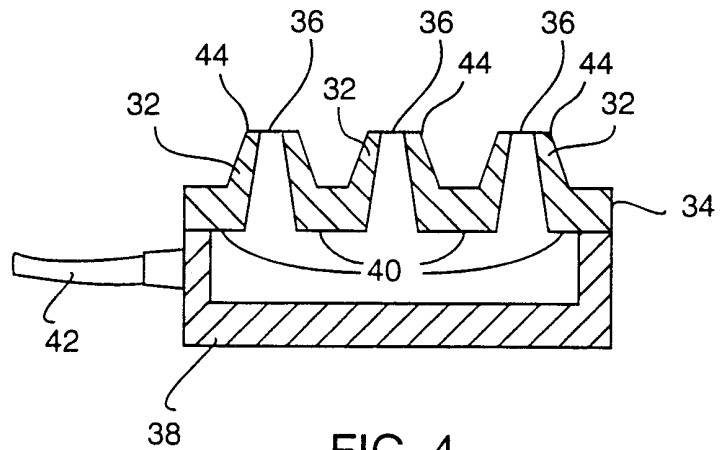

FIG. 4

2 / 6

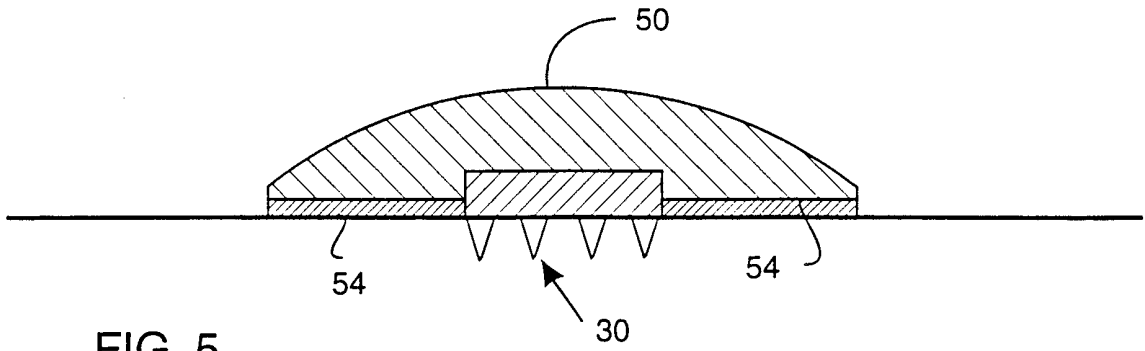

FIG. 5

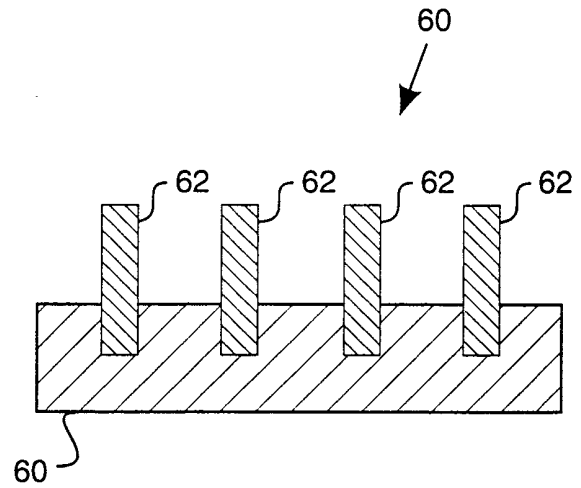

FIG. 6

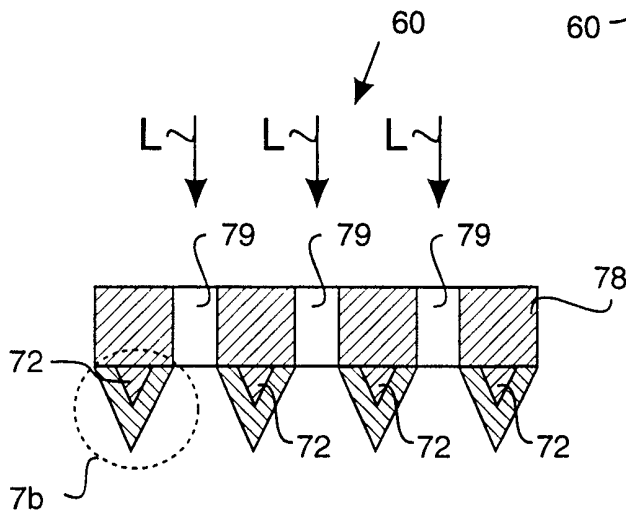

FIG. 7a

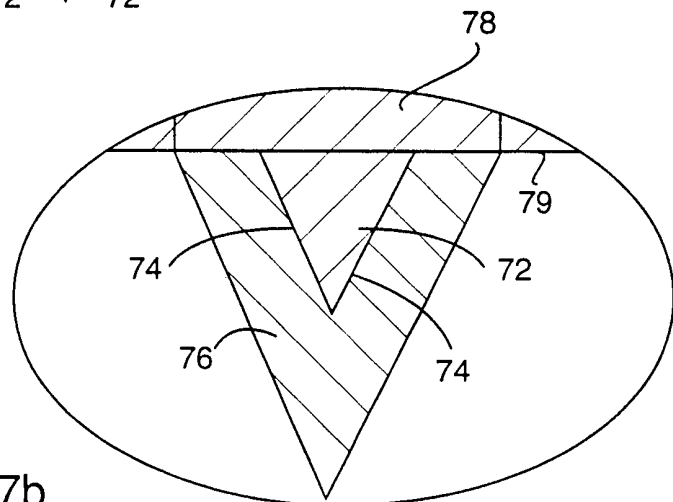

FIG. 7b

FIG. 8

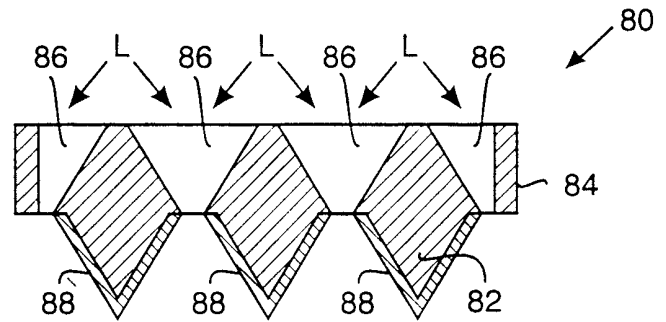

FIG. 9

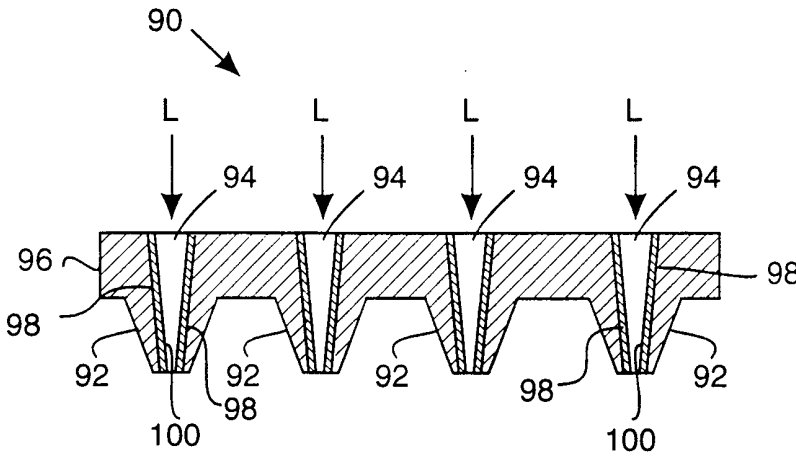

FIG. 10

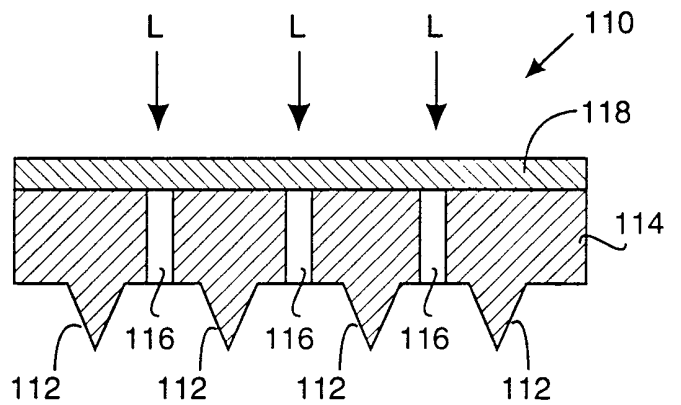
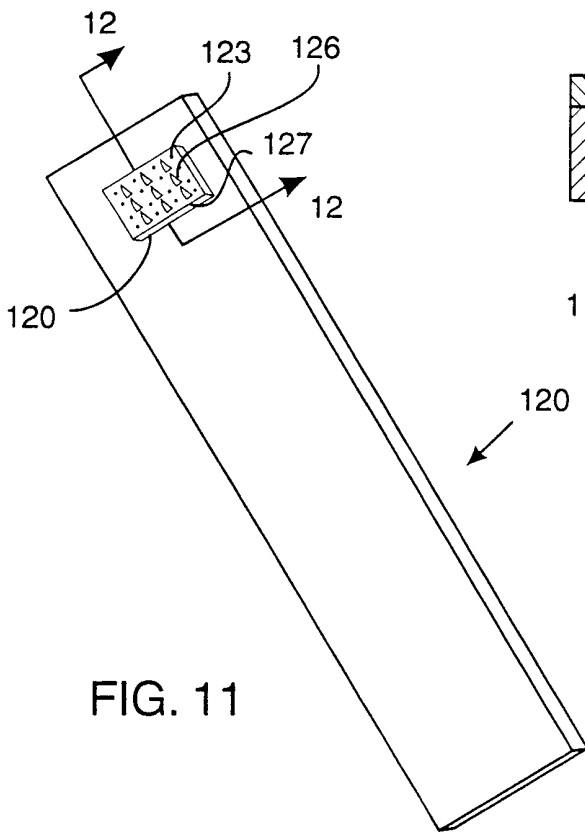

FIG. 11



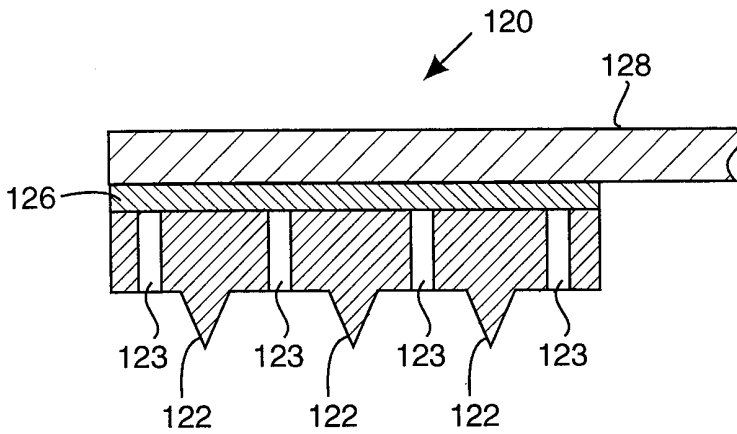

FIG. 12A

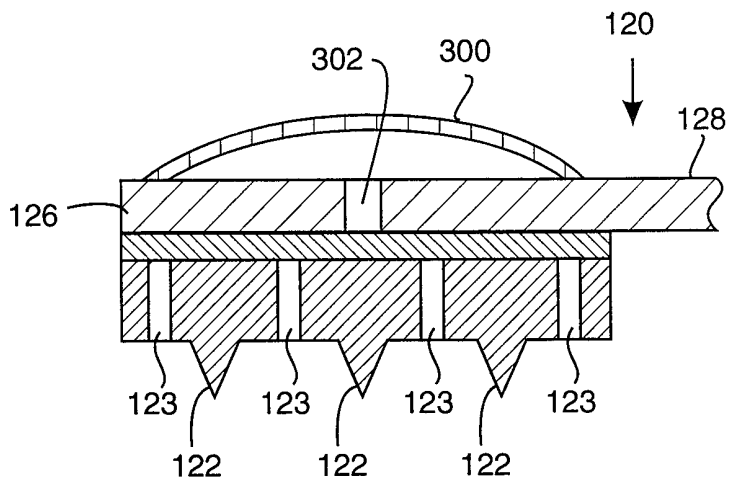

FIG. 12B

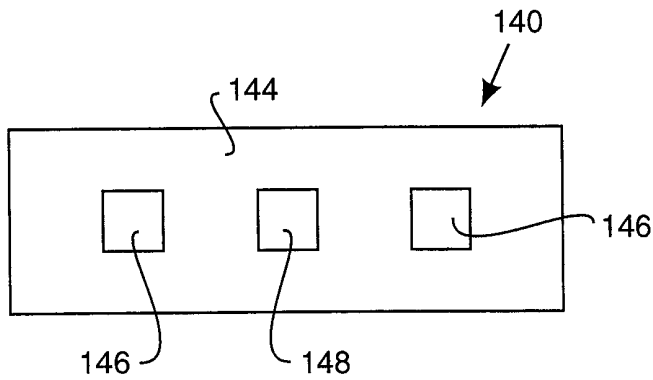

FIG. 13a

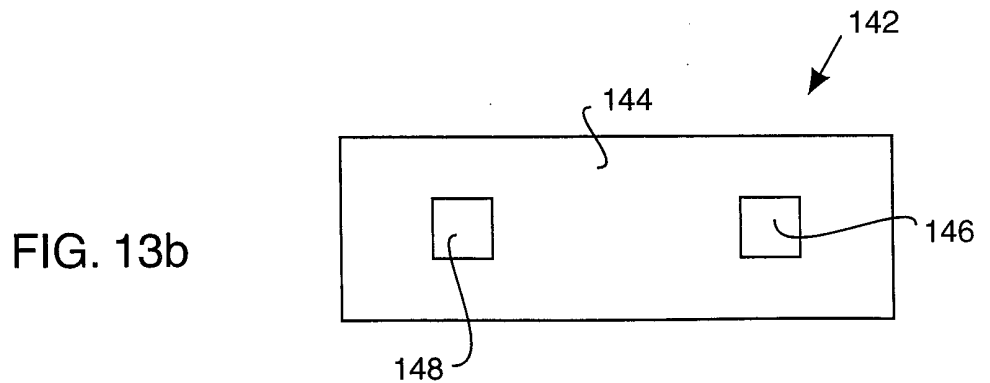
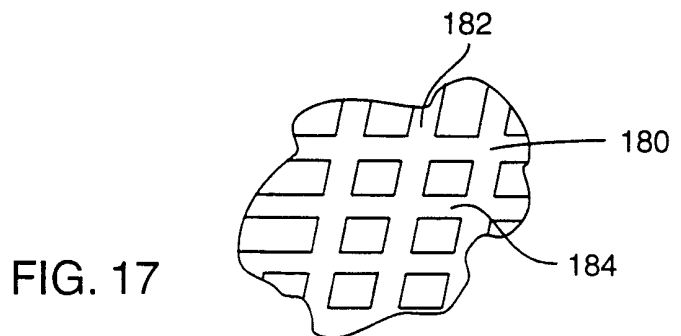
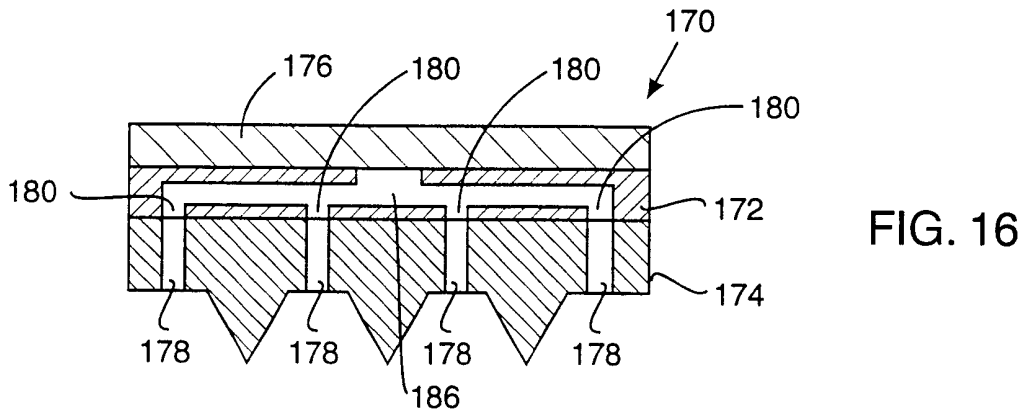
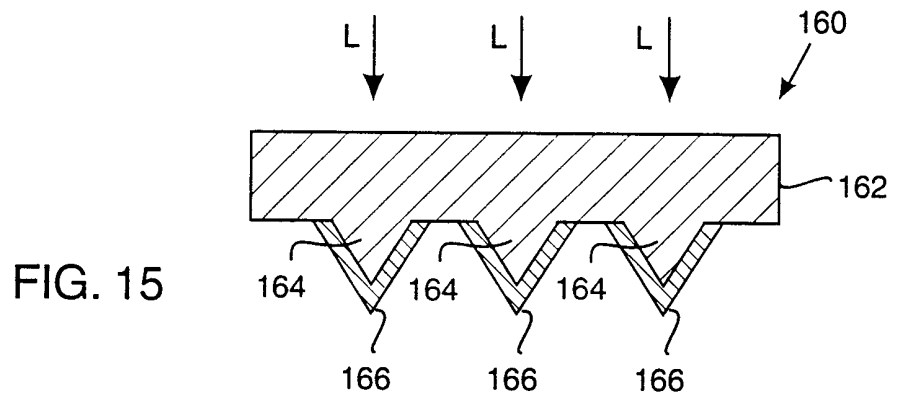
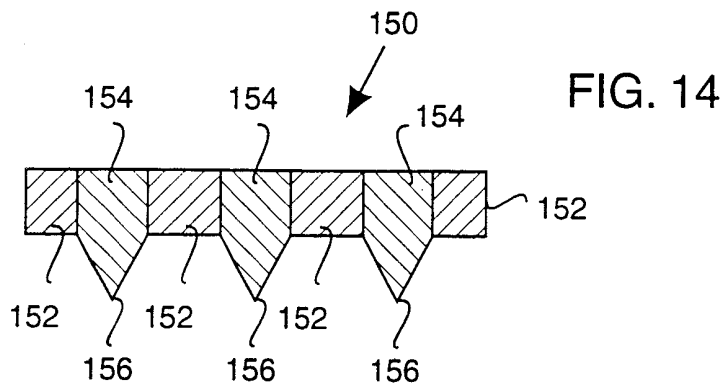

FIG. 13b



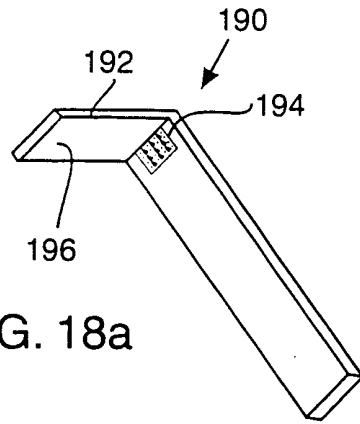

FIG. 18a

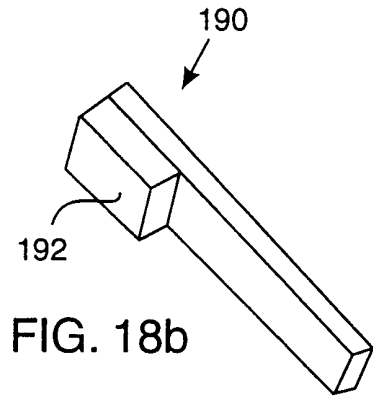

FIG. 18b

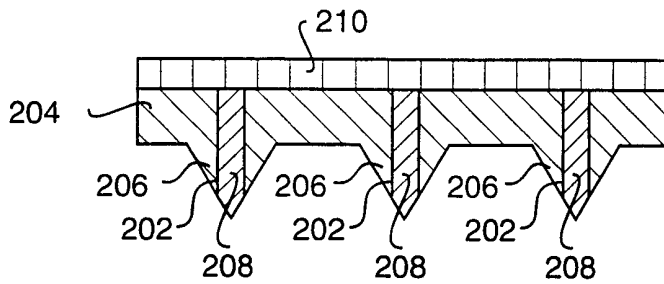

FIG. 19

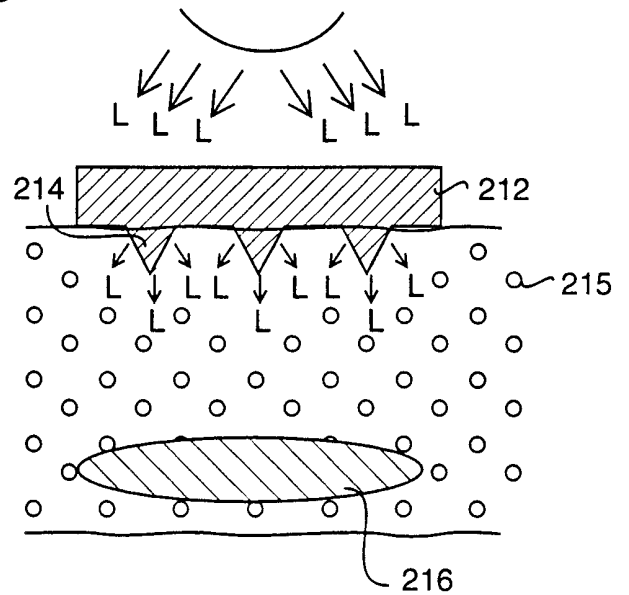

FIG. 20

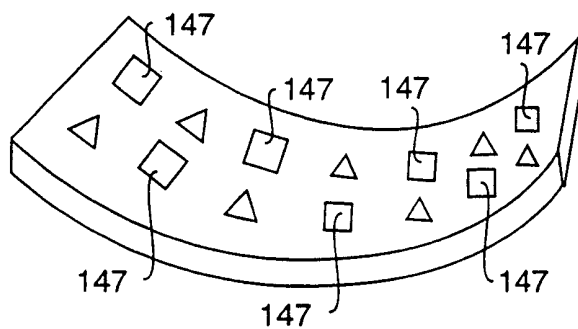

FIG. 21

INTERNATIONAL SEARCH REPORT

International Application No

PCT/US 99/29925

A. CLASSIFICATION OF SUBJECT MATTER
IPC 7 A61M37/00

According to International Patent Classification (IPC) or to both national classification and IPC

B. FIELDS SEARCHED

Minimum documentation searched (classification system followed by classification symbols)

IPC 7 A61M A61K

Documentation searched other than minimum documentation to the extent that such documents are included in the fields searched

Electronic data base consulted during the international search (name of data base and, where practical, search terms used)

C. DOCUMENTS CONSIDERED TO BE RELEVANT

Category *	Citation of document, with indication, where appropriate, of the relevant passages	Relevant to claim No.
X	WO 96 37256 A (SILICON MICRODEVICES INC ;GODSHALL NED A (US)) 28 November 1996 (1996-11-28) page 1, line 15 - line 18 page 5, line 2 - line 13 abstract; figures	1-4, 9-12, 16
A	--- -/--	5-7

Further documents are listed in the continuation of box C.

Patent family members are listed in annex.

* Special categories of cited documents :

"A" document defining the general state of the art which is not considered to be of particular relevance

"E" earlier document but published on or after the international filing date

"L" document which may throw doubts on priority claim(s) or which is cited to establish the publication date of another citation or other special reason (as specified)

"O" document referring to an oral disclosure, use, exhibition or other means

"P" document published prior to the international filing date but later than the priority date claimed

"T" later document published after the international filing date or priority date and not in conflict with the application but cited to understand the principle or theory underlying the invention

"X" document of particular relevance; the claimed invention cannot be considered novel or cannot be considered to involve an inventive step when the document is taken alone

"Y" document of particular relevance; the claimed invention cannot be considered to involve an inventive step when the document is combined with one or more other such documents, such combination being obvious to a person skilled in the art.

"&" document member of the same patent family

Date of the actual completion of the international search

26 April 2000

Date of mailing of the international search report

08/05/2000

Name and mailing address of the ISA

European Patent Office, P.B. 5818 Patentlaan 2
NL - 2280 HV Rijswijk
Tel. (+31-70) 340-2040, Tx. 31 651 epo.nl,
Fax: (+31-70) 340-3016

Authorized officer

Sedy, R

INTERNATIONAL SEARCH REPORT

International Application No

PCT/US 99/29925

C.(Continuation) DOCUMENTS CONSIDERED TO BE RELEVANT		
Category	Citation of document, with indication, where appropriate, of the relevant passages	Relevant to claim No.
X	DE 195 25 607 A (BOEHRINGER INGELHEIM KG) 16 January 1997 (1997-01-16) column 2, line 20 - line 28 column 2, line 50 -column 3, line 1 column 3, line 30 - line 35 column 3, line 50 - line 53 column 4, line 24 - line 28 column 4, line 36 - line 40 claims; figures	1,2,4, 9-11,15, 16
Y	---	17
X	EP 0 081 975 A (MAGANIAS NICHOLAS H) 22 June 1983 (1983-06-22) page 3, line 25 -page 4, line 4 figures	9
A	---	1,5,17
X	US 3 964 482 A (GERSTEL MARTIN S ET AL) 22 June 1976 (1976-06-22)	9
A	the whole document	1,5,17
Y	---	17
Y	US 5 665 065 A (COLMAN FREDRIC C ET AL) 9 September 1997 (1997-09-09) column 4, line 17 - line 19	17
A	---	1,5,9,17
A	WO 96 17648 A (CIBA GEIGY AG ;MANZ ANDREAS (CH); EFFENHAUSER CARLO STEFAN (DE)) 13 June 1996 (1996-06-13) claim 1; figures	1,5,9,17
A	---	5
A	US 5 628 310 A (LAKOWICZ JOSEPH R ET AL) 13 May 1997 (1997-05-13) cited in the application abstract	5
A	---	5
A	US 4 966 159 A (MAGANIAS NICHOLAS H) 30 October 1990 (1990-10-30) column 5, line 17 - line 20 -----	5

INTERNATIONAL SEARCH REPORT

Information on patent family members

International Application No

PCT/US 99/29925

Patent document cited in search report	Publication date	Patent family member(s)	Publication date
WO 9637256 A	28-11-1996	AU 5869796 A	11-12-1996
DE 19525607 A	16-01-1997	AU 6656796 A BG 102200 A BR 9609796 A CA 2226718 A CN 1190904 A CZ 9800118 A WO 9703718 A EP 0840634 A HU 9802773 A JP 11509123 T NO 980147 A PL 324530 A SK 4998 A	18-02-1997 31-08-1998 16-03-1999 06-02-1997 19-08-1998 17-06-1998 06-02-1997 13-05-1998 28-06-1999 17-08-1999 13-03-1998 08-06-1998 09-09-1998
EP 0081975 A	22-06-1983	US 4473083 A AT 23794 T DE 3274422 D JP 58131919 A US 4802493 A US 4966159 A	25-09-1984 15-12-1986 15-01-1987 06-08-1983 07-02-1989 30-10-1990
US 3964482 A	22-06-1976	NONE	
US 5665065 A	09-09-1997	CA 2222070 A EP 0830160 A JP 11507250 T WO 9637246 A	28-11-1996 25-03-1998 29-06-1999 28-11-1996
WO 9617648 A	13-06-1996	AT 177325 T AU 4256496 A CA 2205444 A DE 59505328 D EP 0796128 A JP 10510175 T	15-03-1999 26-06-1996 13-06-1996 15-04-1999 24-09-1997 06-10-1998
US 5628310 A	13-05-1997	AU 711444 B AU 5798896 A CA 2218926 A EP 0952783 A WO 9636275 A	14-10-1999 29-11-1996 21-11-1996 03-11-1999 21-11-1996
US 4966159 A	30-10-1990	US 4473083 A AT 23794 T DE 3274422 D EP 0081975 A JP 58131919 A US 4802493 A	25-09-1984 15-12-1986 15-01-1987 22-06-1983 06-08-1983 07-02-1989