



EUROPEAN PATENT APPLICATION

Application number : **93830367.4**

Int. Cl.⁵ : **E06B 3/46, E05F 15/14,
E05B 65/08**

Date of filing : **10.09.93**

Priority : **21.10.92 IT MI922411**

Inventor : **Berardi, Giuseppe, Scigno S.r.l.
Via G. Pascoli 43
I-47040 Cerasolo Ausa di Coriano, Forli (IT)**

Date of publication of application :
27.04.94 Bulletin 94/17

Representative : **Cicogna, Franco
Ufficio Internazionale Brevetti Dott.Prof.
Franco Cicogna Via Visconti di Modrone, 14/A
I-20122 Milano (IT)**

Designated Contracting States :
**AT BE CH DE DK ES FR GB GR IE LI LU MC NL
PT SE**

Applicant : **SCRIGNO S.r.l.
Via G. Pascoli, 43
I-47040 CERASOLO AUSA DI CORIANO, Forli
(IT)**

Motorized concealable sliding door having an improved box.

On the major faces of the box, which is formed by fretted and galvanized strip elements (4), there are provided grating elements (10) connected by connecting clips (11), suitable to provide a mechanical connection between the grating elements and the box.

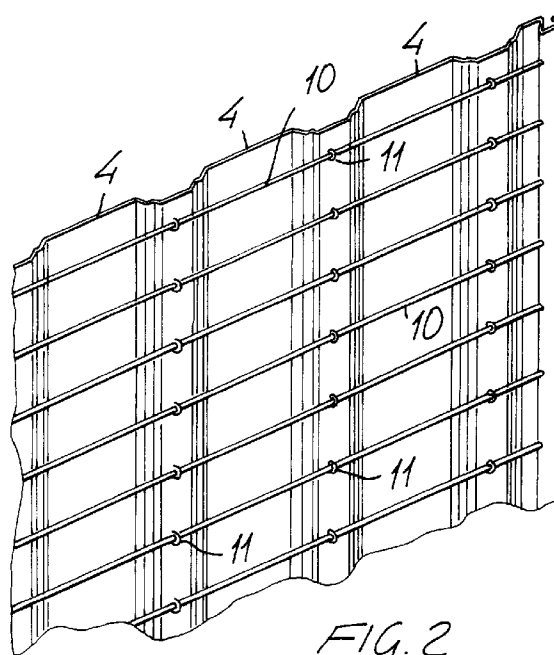

BACKGROUND OF THE INVENTION

The present invention relates to a motorized concealable sliding door, having an improved box.

As is known, there are already commercially available concealable sliding doors to be used both for outside and inside environments, which are provided with a door frame defining a box which is made of fretted strip elements which are connected to one another so as to provide the construction to be introduced into the wall.

In order to facilitate the coupling of the box covering plastering, it is necessary to apply a grating net or the like, extending through the two major faces of the box.

The box, in particular, is made of galvanized sheet metal elements which are damaged in those regions thereof where is performed a high temperature welding operation, that is that type of welding process which must be necessarily used for coupling the grating net to the box.

Under these conditions there are generated spots where the galvanized protection is lacking and at these spots, the assembled metal parts can be easily subjected to rust.

Another problem is that prior solutions are affected by great difficulties, in particular with respect to the application of a driving assembly, since they require a rather complex installation operation with consequent large size and projection of the door from the wall, thereby the wall housing the door can not be practically further exploited.

Another drawback of prior solutions is that prior sliding doors of the above mentioned type are scarcely flexible in operation and, moreover, they do not afford the possibility of making a double sliding door, since the prior constructions are not suitable to provide the necessary width for a double sliding door.

Yet another problem, moreover, is that of a poor thermal insulation of prior sliding doors, with consequent great thermal loss spots through the door.

SUMMARY OF THE INVENTION

Accordingly, the aim of the present invention is to overcome the above mentioned drawbacks, by providing a motorized concealable sliding door including an improved box, in which there are completely eliminated the welded regions necessary for connecting the grating net and the box strip elements, so that the sliding door can be advantageously used mainly in outside applications.

Within the scope of the above mentioned aim, a main object of the present invention is to provide such a motorized sliding door, which allows to house its driving motor in a very compact manner, so as to prevent projecting regions from being generated with respect to the wall, thereby allowing the wall to be ex-

ploited for other applications.

Another object of the present invention is to provide such a door construction in which the rails, together with the driving members, can be reassembled outside of the door box and then can be mounted by a quick connection system on the top cross member of the door.

Yet another object of the present invention is to provide such a sliding door which is very reliable and safe in operation.

According to one aspect of the present invention, the above mentioned aim and objects, as well as yet other objects, which will become more apparent hereinafter, are achieved by a motorized concealable sliding door, having an improved box, comprising a frame defining sliding rails for at least a door wing, and a box, suitable to be housed inside a wall, characterized in that on the major faces of said box, formed by fretted and galvanized strip like elements, there are provided grating elements which are connected by connecting clips suitable to mechanically connect said strip elements and box.

BRIEF DESCRIPTION OF THE DRAWINGS

Further characteristics and advantages of the present invention will become more apparent hereinafter from the following description of a preferred, though not exclusive, embodiment of a motorized concealable sliding door provided with an improved box, which is illustrated, by way of an indicative but not limitative example, in the accompanying drawings, where:

Figure 1 is a schematic elevation view illustrating the motorized sliding door according to the invention, and in which there is clearly also shown the door box;

Figure 2 shows a major or main wall or panel of the box, to which there is applied a grating net; Figure 3 is a schematic cross-sectional view illustrating the connection between the grating net and box;

Figure 4 is a horizontal cross-sectional view illustrating the box with the grating net and thermally insulating layers;

Figure 5 is a schematic top-plane and cross-sectional horizontal view of the sliding door according to the present invention;

Figure 6 is a cross-sectional view illustrating the top sliding guides of the door;

Figure 7 is an elevation view illustrating the driving means for driving the sliding door;

Figure 8 is a top plane view of the subject driving means.

Figure 9 illustrates a motor-reducing unit for manually driving the door;

Figure 10 is a cross-sectional view illustrating the electric closure door bolt;

Figure 11 is a perspective view of the door bolts; and
 Figure 12 is a vertical cross-sectional view illustrating a sliding door provided with a double sliding door wing.

DESCRIPTION OF THE PREFERRED EMBODIMENTS

With reference to the number references of the above disclosed figures, the motorizing concealable sliding door provided with an improved door box according to the present invention, which has been generally indicated at the reference number 1, comprises a door frame 2, which is advantageously made of suitably contoured sheet metal section members and which defines a door box 3 arranged adjoining the opening port of the door.

This box, in particular, is made of fretted strip like elements 4 which are slidably connected to one another and caulked so as to mutually lock these elements.

The strip elements are connected by a bottom strip element 5 closing at the end the door box.

As stated, the door box is made of galvanized fretted strip like elements and, heretofore, it was very difficult to connect to the door box the grating net 10 which is conventionally used for coupling the wall finishing plastering applied on the wall in which the door box is usually housed.

A main feature of the present invention is that the grating net 10 is connected by clips 11 which are engaged on strip-like elements and suitably bent so as to provide a mechanical type of connection, which does not damage the galvanized protection.

Inside the door box there are provided thermally insulated layers 12, providing a very good thermal insulation and barrier against heat losses.

Another important feature of the present invention is that there are provided motorizing or driving means, comprising an electric motor 20 which is connected to the top cross-member of the door frame and is arranged at an intermediate portion of the door.

The electric motor 20, through a bevel gear pair 21, drives a toothed pulley 22, entraining a toothed belt, indicated at the reference number 23, connected to one of the truck assemblies 24 supporting the door.

The toothed belt 23 is further entrained on a transmission toothed pulley 25, arranged near the rabbet of the door and also supported by the top cross-member.

As is clearly shown in figure 6, the truck assemblies 24 can slide on rails 25 having a C-shape and also connected to the top cross-member 26 of the door frame.

To the truck assemblies 24 there is connected a wing, indicated at the reference number 30, which, owing to the very good strength of this construction,

can also have a comparatively great weight.

Moreover, the motor further comprises a coaxial-axis motor reducing unit, which allows the possibility of manually opening the door in case of power failure or other emergency cases.

In this connection it should be apparent that by arranging the electric motor not at the end portions of the rail, but slightly beyond the start part of the box, it is possible, with respect to prior systems, to reduce the length of the driving assemblies, with a consequent small size and effective damping of possible vibration.

In order to open the door, at the abutment edge of the wing 30 there is provided a guide vertical section member 31 of omega shape, inside which can slide a small bolt 32, comprising a bolt rod including a contoured elongated slot 33, engaging with a locking pin element 34 provided on the door rabbet.

At the top the bolt 32 is provided with a bolt block 35, having a recess 36 in which can be engaged the head portion 37 of a rod 38 connected to an electromagnet 39 which will drive the bolt 32 from its locking position to its releasing position and vice versa.

With the disclosed connection assembly, the electromagnet is housed in the fixed door part and will cause the contoured head 37 to be engaged in the seat 36, as the door wing 30 is closed, and then it will allow the subsequent translating motion providing the locking of the door.

In order to release this locking, for example in a case of power failure, there is provided a manual unlocking lever, indicated at the reference number 40, which directly operates on the electromagnet.

As is shown in figure 12 it is also possible, by holding those same designing features which have been above disclosed, to provide a sliding double wing door, the wings of which are indicated at 30a and 30b, which are arranged adjoining one another and housed in a door box which, consequently, will have a greater width.

From the above disclosure it should be apparent that the invention fully achieves the intended aim and objects.

In particular, the fact is to be pointed out that a sliding door has been made, both for outside and inside use, in which the grating net can be applied to the door box in a very satisfactory way, owing to the provision of the above disclosed clips, which are mechanically connected in the galvanized region without damaging the latter.

Another very important aspect of the present invention is that the electric motor is so arranged that it allows to reduce to a minimum the occupied space, and moreover provides a very improved operation.

The invention as disclosed is susceptible to several modifications and variations all of which will come within the scope of the inventive idea.

Moreover, all of the details can be replaced by

other technically equivalent elements.

In practicing the invention, the used material, as well as the contingent size and shape can be according to requirements.

Claims

1. A motorized concealable sliding door, having an improved box, comprising a frame defining sliding rails for at least a door wing, and a box, suitable to be housed inside a wall, characterized in that on the major faces of said box, formed by fretted and galvanized strip like elements, there are provided grating elements which are connected by connecting clips suitable to mechanically connect said strip elements and box. 10 15
2. A motorized sliding door, according to Claim 1, characterized in that said door further comprises thermally insulating material layers arranged on the inner walls of said door box. 20
3. A motorized sliding door, according to Claims 1 and 2, characterized in that said door further comprises a motorizing assembly for driving the door wing, which can be pre-assembled outside of the door box and can be applied by a quick connection system on the top cross-member of the door. 25 30
4. A motorized sliding door, according to one or more of the preceding claims, characterized in that said driving assembly is arranged substantially at a central portion of said door box. 35
5. A motorized sliding door, according to one or more of the preceding claims, characterized in that said driving assembly is connected through a bevel gear pair to a toothed pulley cooperating with a toothed belt entrained on a transmission toothed pulley and being connected to one of the door wing sliding truck assemblies. 40
6. A motorized sliding door, according to one or more of the preceding claims, characterized in that said door further comprises a motor-reducing unit of the coaxial-axis type, for allowing the door to be manually opened. 45 50
7. A motorized sliding door, according to one or more of the preceding claims, characterized in that said door further comprises a bolt element for closing the door wing, said bolt element being omega shaped and connected at the door wing abutment edge, in said omega shaped bolt there being slidably provided a locking element including at least an elongated slot engageable with a 55

locking pin elements provided on the fixed frame of the door, said locking element being connected to a top block element and being provided with a mating seat which can be connected to a shaped head portion in turn connected to an electromagnet mounted on the door top cross member.

8. A motorized sliding door, according to one or more of the preceding claims, characterized in that said door further comprises two adjoining sliding door wings.

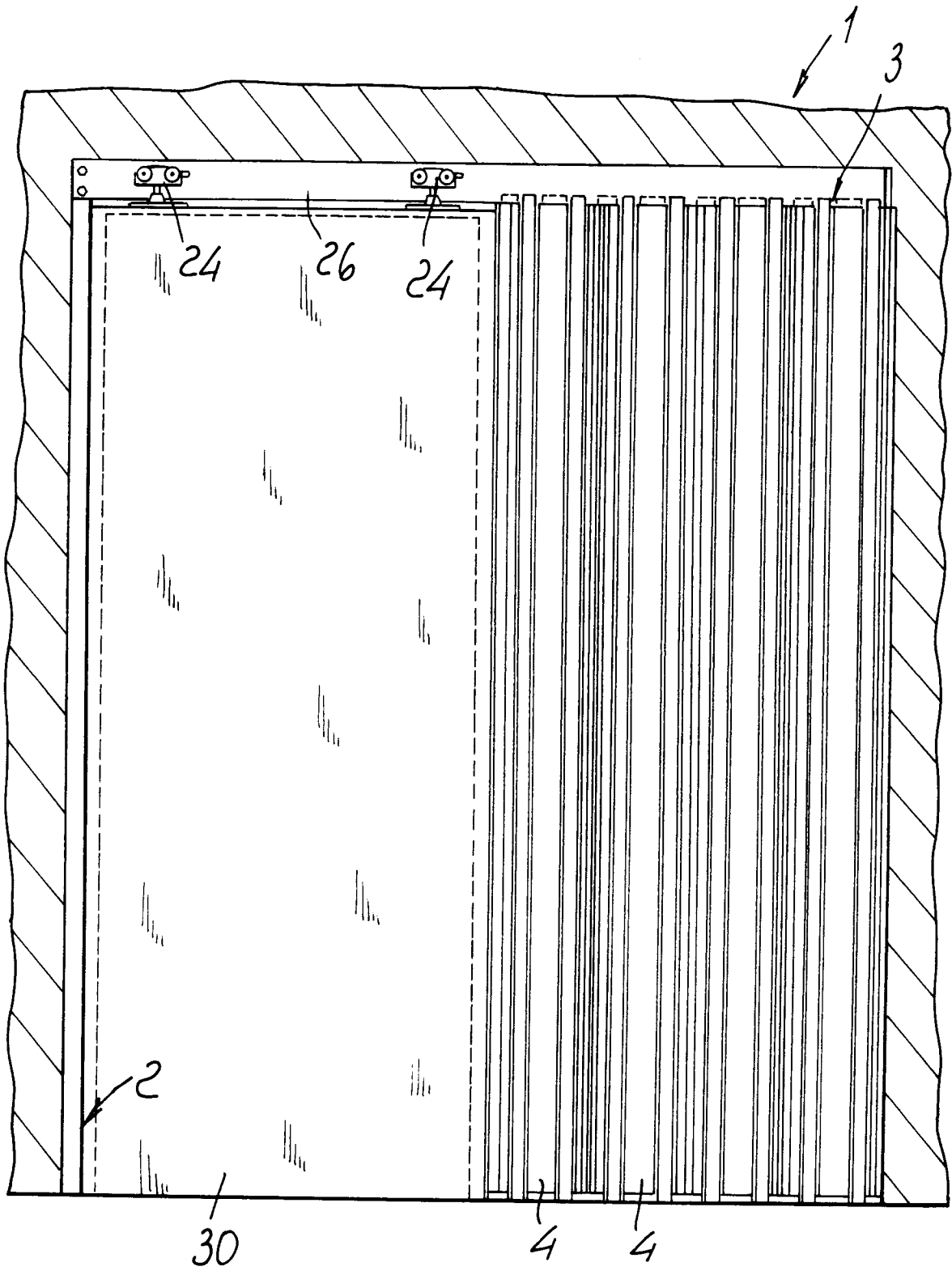

FIG. 1

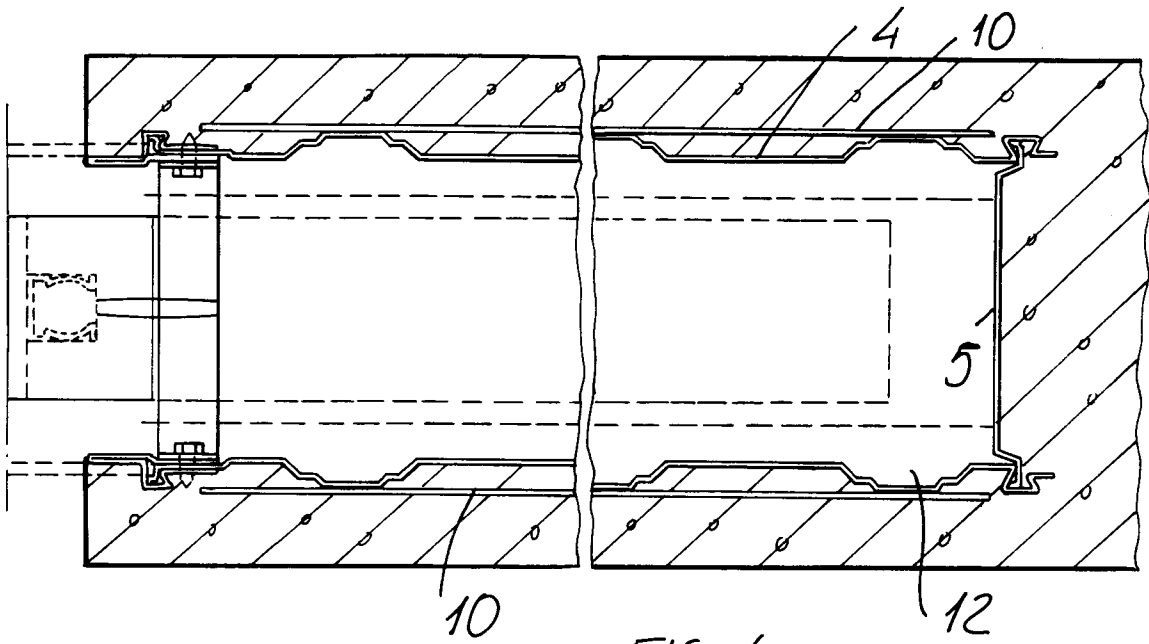

FIG. 4

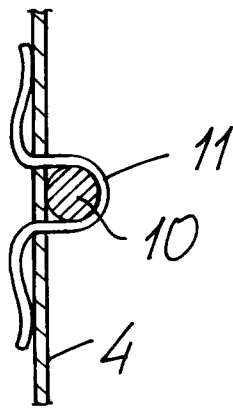

FIG. 3

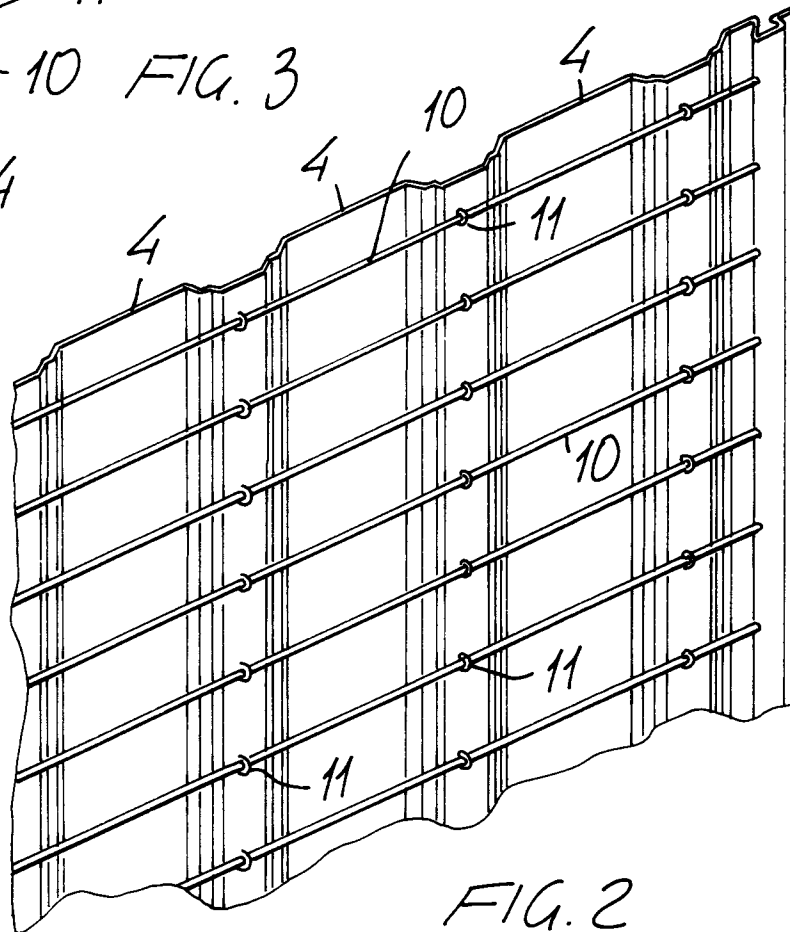

FIG. 2

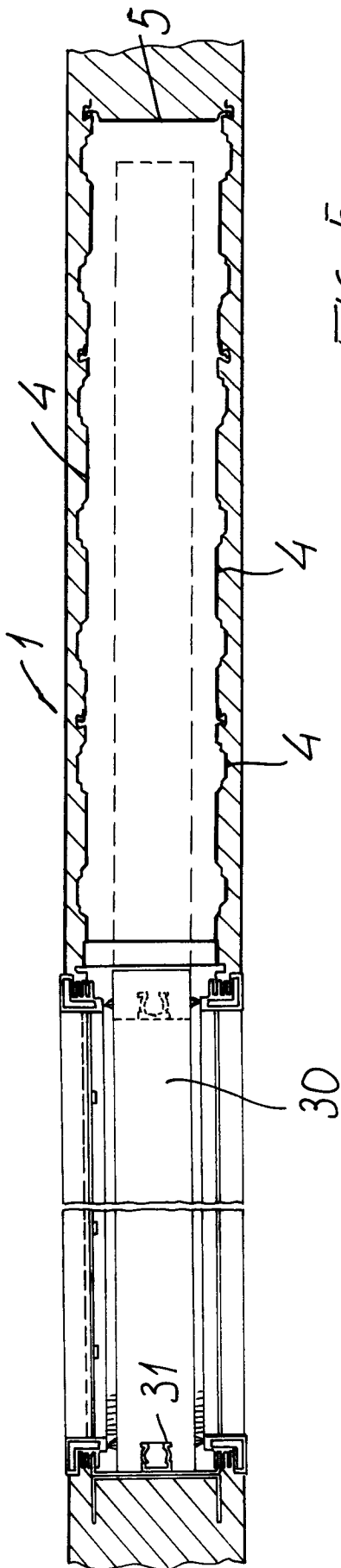

FIG. 5

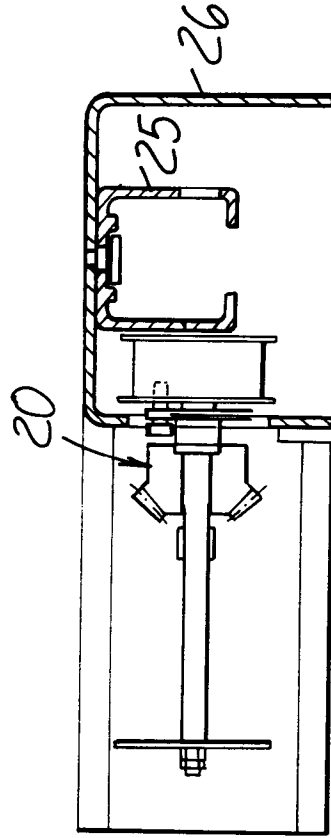

FIG. 9

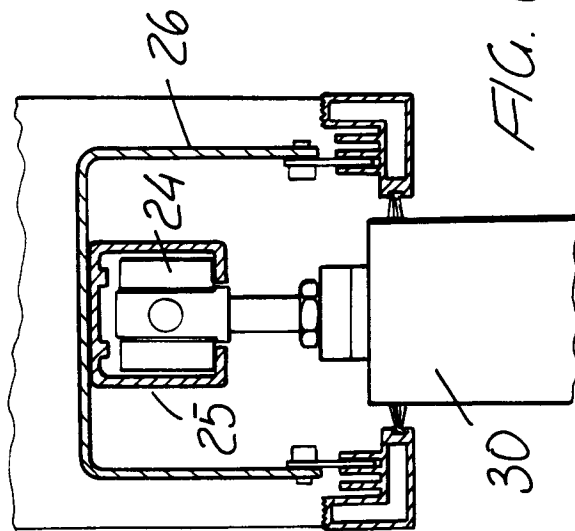

FIG. 6

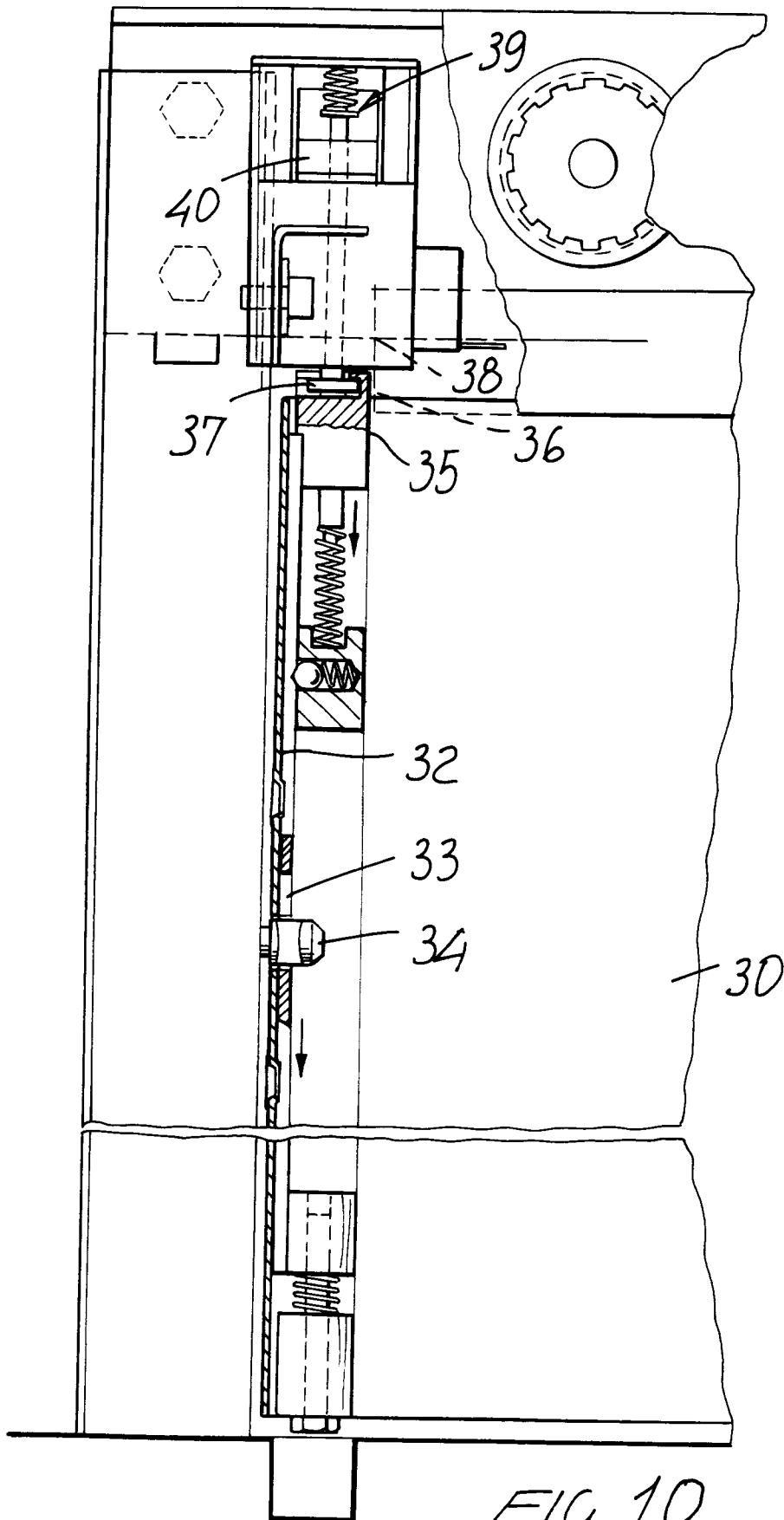

FIG. 10

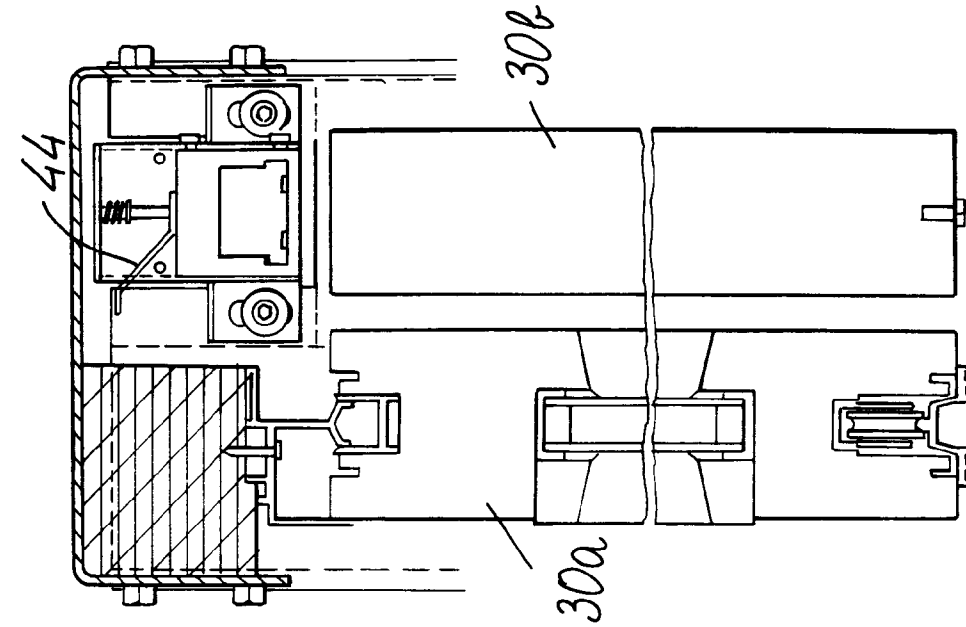

FIG. 12

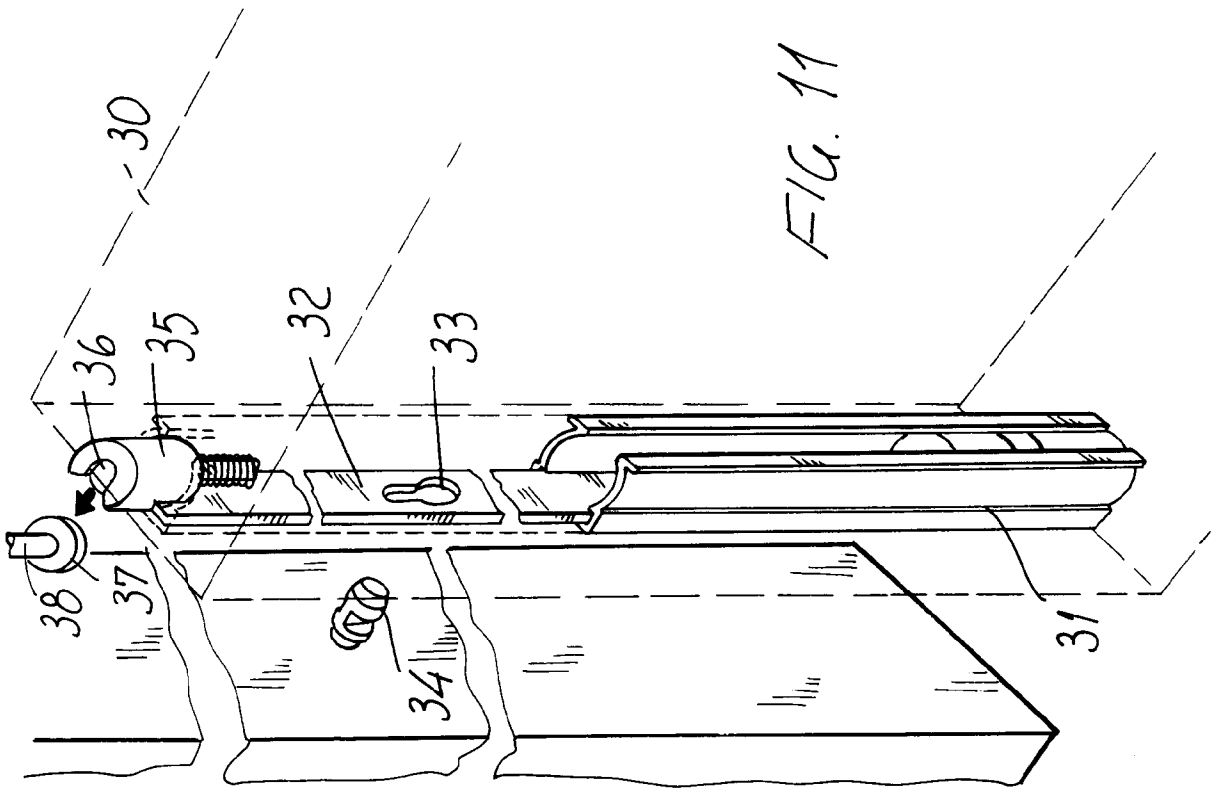
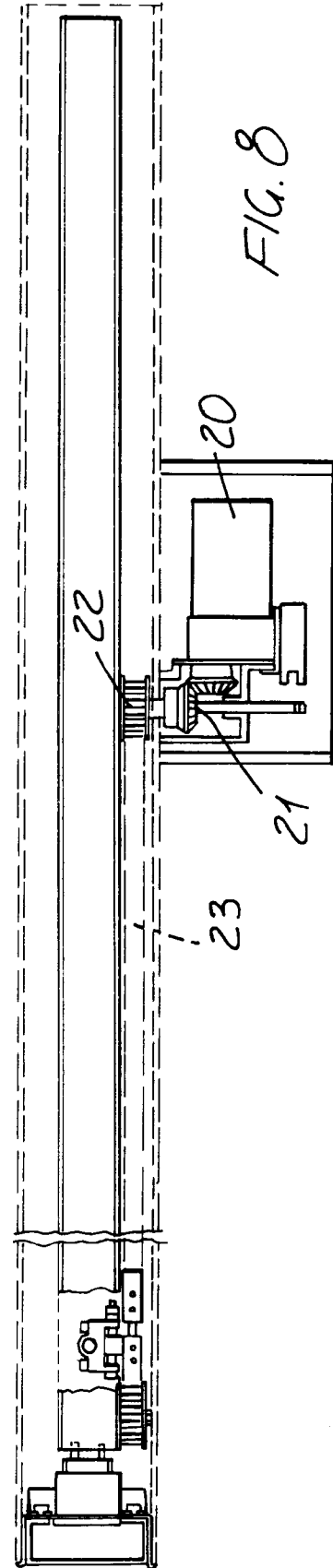
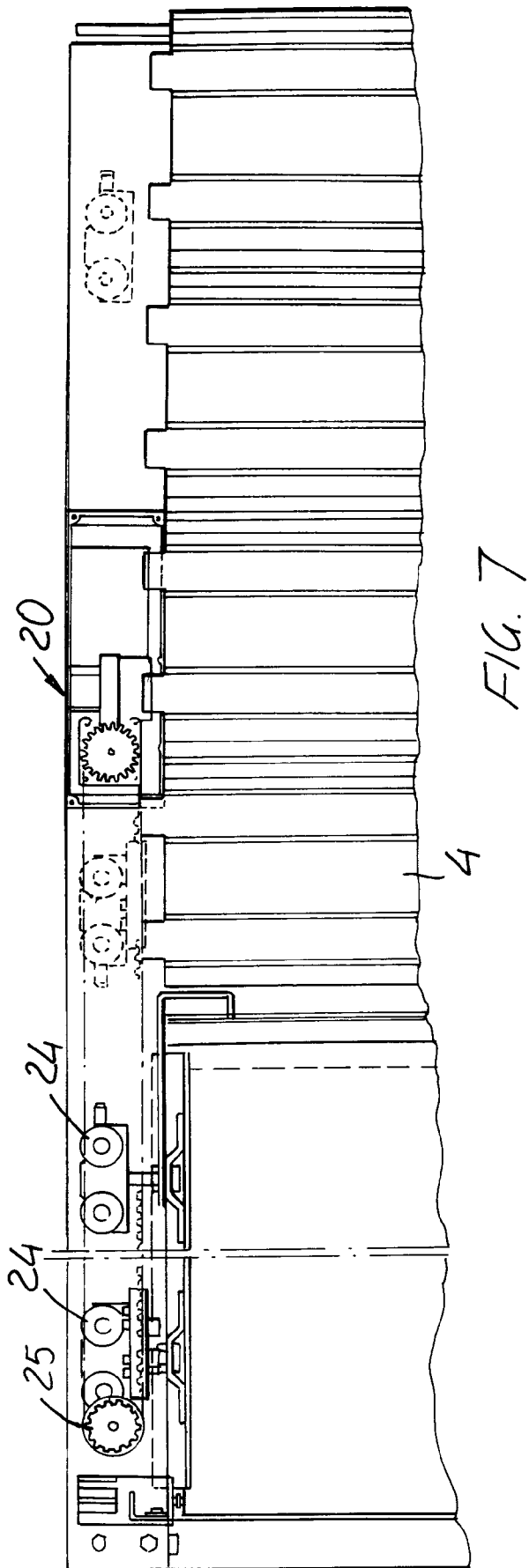

FIG. 11





European Patent
Office

EUROPEAN SEARCH REPORT

Application Number
EP 93 83 0367

DOCUMENTS CONSIDERED TO BE RELEVANT			
Category	Citation of document with indication, where appropriate, of relevant passages	Relevant to claim	CLASSIFICATION OF THE APPLICATION (Int.Cl.5)
Y	EP-A-0 505 614 (DE FAVERI) * column 1, line 28 - line 57 * * column 4, line 37 - column 5, line 2 * * claims 1,2,8-12 * * figures * ---	1	E06B3/46 E05F15/14 E05B65/08
Y A	EP-A-0 312 417 (DELAPORTE) * the whole document * ---	1 3-5	
A	FR-A-1 518 017 (FERMETURES MISCHLER) * page 2, left column, paragraph 13 - right column, paragraph 8 * * page 3, right column, paragraph 2 -paragraph 7 * * page 4, left column, paragraph 3 -paragraph 7 * * figures 1-3,11-21 * ---	1-5,7	
A	EP-A-0 225 675 (KOMPIER & VAN ROOIJ) * the whole document * ---	1-3	
A	US-A-4 385 470 (BRYSON ET AL) * column 3, line 3 - column 4, line 54 * * figures 1,2,6 * ---	1,2	TECHNICAL FIELDS SEARCHED (Int.Cl.5) E06B E04F
A	US-A-4 050 189 (PETERSON) * column 2, line 12 - line 24 * * column 3, line 1 - column 4, line 14 * * figures 1-3 * ---	1,3,5	
A	GB-A-819 531 (LIGHT STEEL SECTIONAL CONSTRUCTIONS) * page 2, line 24 - line 55 * * figures 1-3 * ---	1	
A	US-A-2 026 886 (GOELTZ ET AL) * page 1, right column, line 21 - line 53; figures * ---	1	
		-/--	
The present search report has been drawn up for all claims			
Place of search THE HAGUE		Date of completion of the search 28 January 1994	Examiner Depoorter, F
CATEGORY OF CITED DOCUMENTS		T : theory or principle underlying the invention E : earlier patent document, but published on, or after the filing date D : document cited in the application L : document cited for other reasons & : member of the same patent family, corresponding document	
X : particularly relevant if taken alone Y : particularly relevant if combined with another document of the same category A : technological background O : non-written disclosure P : intermediate document			

EPO FORM 1503 01.82 (P04/C01)



European Patent
Office

EUROPEAN SEARCH REPORT

Application Number
EP 93 83 0367

DOCUMENTS CONSIDERED TO BE RELEVANT			
Category	Citation of document with indication, where appropriate, of relevant passages	Relevant to claim	CLASSIFICATION OF THE APPLICATION (Int.Cl.5)
A	US-A-3 247 615 (KALOG) * column 1, line 58 - column 2, line 7; figure 1 * ---	3	
A	FR-A-664 371 (MARCHAND) * page 1, line 1 - page 2, line 81; figures * -----	8	
The present search report has been drawn up for all claims			TECHNICAL FIELDS SEARCHED (Int.Cl.5)
Place of search THE HAGUE		Date of completion of the search 28 January 1994	Examiner Depoorter, F
<p>CATEGORY OF CITED DOCUMENTS</p> <p>X : particularly relevant if taken alone Y : particularly relevant if combined with another document of the same category A : technological background O : non-written disclosure P : intermediate document</p> <p>T : theory or principle underlying the invention E : earlier patent document, but published on, or after the filing date D : document cited in the application L : document cited for other reasons & : member of the same patent family, corresponding document</p>			

EPO FORM 1503 (03.82) (P04C01)