

(19)



(11)

EP 3 296 095 B1

(12)

EUROPEAN PATENT SPECIFICATION

(45) Date of publication and mention of the grant of the patent:
28.06.2023 Bulletin 2023/26

(51) International Patent Classification (IPC):
B30B 9/30 (2006.01) B65F 1/14 (2006.01)
B30B 1/00 (2006.01) B65F 1/10 (2006.01)
B65F 1/16 (2006.01)

(21) Application number: **17199774.5**

(52) Cooperative Patent Classification (CPC):
B30B 9/3046; B65F 1/10; B65F 1/1405;
B65F 1/1447; B65F 1/1615; B65F 2210/168;
B65F 2210/172

(22) Date of filing: **03.03.2016**

(54) REFUSE COLLECTION AND COMPACTION DEVICES

ABFALLSAMMEL- UND VERDICHTUNGSVORRICHTUNGEN

DISPOSITIFS DE COMPACTAGE ET DE COLLECTE D'ORDURES

(84) Designated Contracting States:
AL AT BE BG CH CY CZ DE DK EE ES FI FR GB
GR HR HU IE IS IT LI LT LU LV MC MK MT NL NO
PL PT RO RS SE SI SK SM TR

(72) Inventors:
• **Timmerman, Jacob Koert**
9404 AW ASSEN (NL)
• **Verschoor, Cornelis Geert**
3405 BH BENSCHOP (NL)

(30) Priority: **05.03.2015 NL 2014400**
15.04.2015 NL 2014644

(74) Representative: **EP&C**
P.O. Box 3241
2280 GE Rijswijk (NL)

(43) Date of publication of application:
21.03.2018 Bulletin 2018/12

(62) Document number(s) of the earlier application(s) in accordance with Art. 76 EPC:
16722405.4 / 3 265 303

(56) References cited:
EP-A1- 1 508 535 CH-A1- 704 762
CN-Y- 201 228 156 DE-A1- 2 202 156
DE-A1-102006 031 131 GB-A- 1 477 311
JP-A- H09 136 191 NL-A- 7 900 279
NL-C2- 1 000 419

(73) Proprietor: **Mr. Fill Holding B.V.**
4104 BG Culemborg (NL)

EP 3 296 095 B1

Note: Within nine months of the publication of the mention of the grant of the European patent in the European Patent Bulletin, any person may give notice to the European Patent Office of opposition to that patent, in accordance with the Implementing Regulations. Notice of opposition shall not be deemed to have been filed until the opposition fee has been paid. (Art. 99(1) European Patent Convention).

Description

[0001] The present invention relates to the field of collector and compactor devices, in particular to the field of vertical compactor devices that compact refuse collected in an exchangeable bin open at the top.

[0002] Known vertical refuse collector and compactor devices generally comprise a housing with a refuse insertion opening. Refuse inserted through the refuse insertion opening is collected in an exchangeable bin, e.g. a wheeled bin, provided in the interior of the housing. Known vertical refuse collector and compactor devices further comprise a compactor unit adapted to press on the collected refuse to reduce its volume. The compactor unit generally comprises a press element, such as a plate, that during compaction moves from a higher position above or near the top of the bin to a lower position inside the bin, thereby pressing the collected refuse in the bin further down. The compactor unit furthermore generally comprises a frame attached to the housing and a hinged construction that connects the press element to the frame. Through compaction more refuse can be collected in a bin of a given size, thus reducing costs associated with emptying and/or replacing full bins.

[0003] WO2006073224 discloses a vertical refuse collector and compactor device comprising a housing to hold an exchangeable open topped bin, said housing having a front face with a refuse insertion opening, a rear face and a top face. The device further includes a compactor unit comprising a frame attached to said housing and two parallel spaced apart upper pivot links. The upper pivot links are at one end connected to the frame at a first pivot axis, said first pivot axis being a horizontal axis near the rear face of the housing. The compactor unit further comprises one front pivot link connected at a second pivot axis to said upper pivot links, said second pivot axis being at the end of the upper pivot link opposite the first pivot axis and parallel to the first pivot axis. The compactor unit further comprises a press element, connected to said front pivot link at the end thereof opposite the second pivot axis, and two parallel lower pivot links, substantially parallel to the two upper pivot links. The press element is formed as two horizontal rods at right angles to each other with foldable extension rods pivotally attached to the ends of each rod. Said two lower pivot links are at one end connected to the frame at a third pivot axis, said third pivot axis being below the first pivot axis and parallel to the first pivot axis. Said two lower pivot links are connected to front pivot link at a fourth pivot axis, said fourth pivot axis being at the ends of the lower pivot links opposite the first pivot axis and parallel to the first pivot axis. The compactor unit further comprises an actuator adapted to impart to the press element a vertical motion from an upper retracted position, in which the upper pivot links tilt toward the top of the housing, to a lower pressing position and vice versa for compacting refuse. The compactor unit further comprises a motor to drive said actuator.

[0004] Several drawbacks to the vertical refuse collector of WO2006073224 can be pointed out. As the press element hangs above the bin at a height only slightly above the top of the bin and at the same height as the refuse insertion opening, refuse that enters the housing through the refuse insertion opening can easily fall on top of the press element, which is unwanted as the refuse cannot be compacted properly and may lead to malfunction of the compactor. Moreover, the two horizontal rods of the press element only press upon a small portion of the upper layer of refuse collected the bin, thus realizing only little compaction. Lastly, the hinged construction disclosed in WO2006073224 may not be able to exert a large enough pressing force and thus may not allow the desired level of compaction of the refuse.

[0005] Document CN 201 228 156 Y, on which the preamble of claim 1 is based, discloses a refuse collector and compactor device comprising a housing adapted to hold an exchangeable open topped bin. The housing has a front face with a refuse insertion opening. The device further comprises a compactor unit with a frame attached to the housing, upper pivot links, lower pivot links, front pivot links, and rear pivot links. A press element is connected to the front and rear pivot links. The press plate is actuated to move from a tilted orientation in an upper retracted position, with the edge of the press plate closest to the front face of the housing elevated with respect to the edge near the rear face of the housing, to a substantially levelled orientation in the lower pressing position.

[0006] The object of the present invention is to provide a vertical refuse collection and compaction device that overcomes one or more of the abovementioned drawbacks. In particular, the present invention provides a refuse collection and compactor device in which refuse collection is not hindered by the presence of the compactor unit, while at the same time providing a compactor unit that allows to be economic of space. With economic of space it is meant that the addition of the compactor unit within a housing adapted to hold an exchangeable open topped bin, said housing having a front face with a refuse insertion opening, requires only a limited enlargement of the housing (approximately maximally 10-20 percent of the original volume of the housing). In particular the compaction unit does not require the height of the housing to be much increased compared to the height of the housing without compactor unit. This is e.g. advantageous in public areas where the device might otherwise be an undesirable obstacle.

[0007] The present invention provides a refuse collector and compactor device according to claim 1 and a method for collecting and compacting refuse according to claim 14.

[0008] In a preferred embodiment the distance between the fourth pivot axis and the fifth pivot axis moreover equals the distance between the seventh and the sixth pivot axis, so that the tilt of the press plate is substantially equal to the tilt of the upper pivot links.

[0009] The hinged construction that comprises one or

more upper pivot links, one or more lower pivot links, one or more front pivot links and one or more rear pivot links, interconnected and connected to the press plate as described above with the rear pivot links connected at the seventh pivot axis to said one or more lower pivot links results in a tilt of the press plate with a tilting angle with respect to the horizontal about an axis parallel to the first pivot axis. Said tilting angle of the press plate is in a fixed relation to the angle of the upper pivot links to the horizontal. For instance, in a preferred embodiment the distance between the fourth pivot axis and the fifth pivot axis equals the distance between the seventh and the sixth pivot axis, so that the angle of the press plate with respect to horizontal is equal to the angle of the upper pivot links to the horizontal. The distance between the fourth pivot axis and the fifth pivot axis may also be smaller or larger than the distance between the seventh and the sixth pivot axis, so that the press plate is for instance tilted upwards at its front edge when the one or more upper pivot links are oriented horizontally and becomes levelled when the upper pivot links are rotated further downwards. The same angle of the press plate and the upper pivot links is preferred as this leads to a most economic of space compactor unit in the retracted position.

[0010] In the pressing position the press plate is preferably substantially levelled to press upon a large part of the refuse contained in the collector unit. In the pressing position the angle between upper pivot links and front pivot links is large, e.g. 60-120 degrees.

[0011] In the retracted position the upper pivot links tilt toward the top of the housing and as the lower pivot links are parallel to the upper pivot links also the lower pivot links are tilted toward the top of the housing. In the retracted position the angle between the upper pivot links and the front pivot links is small, e.g. 0-30 degrees. The rear pivot links are parallel to the front pivot links and are thus at the same small angle to the front pivot links. The front and rear pivot links are thus substantially folded against the upper and lower pivot links. The press plate is in the preferred embodiment tilted at the same angle as the upper pivot links and the angle between the front pivot links and the press plate is therefore small, e.g. 0-30 degrees.

[0012] In the retracted position the press plate seen from the front face of the housing, e.g. through the insertion opening, at least partially covers the hinged construction formed by the upper pivot links, lower pivot links, front pivot links and rear pivot links. From this viewpoint the press plate may also partially or entirely cover the actuator and motor. The folding of the hinged construction and the tilting of the press plate thus leads to an economic of size compactor unit in the retracted position. It also strongly reduces the chance that refuse inserted into the bin through the refuse insertion opening will get stuck on top of the press plate and/or in the hinged construction. Also, as the hinged construction may thus be hidden from view, it is unlikely that it will be tampered with.

[0013] The vertical refuse collector and compactor de-

vice is to be used with an exchangeable bin, possibly wheeled, e.g. two wheels at one lower corner, open at the top and placed in the housing. When the bin is empty or only partially filled the compactor unit is in the retracted position above the exchangeable bin. In order to detect the fill level in the bin a sensor is provided. Only when the bin is substantially filled with refuse the compactor unit moves from the retracted position to the pressing position. During the motion from the retracted position to the pressing position the press plate enters the exchangeable bin and moves downward down to a height that is preferably between 70 and 90 % of the height of the bin, thereby compacting the refuse. Subsequently the compactor moves back to the retracted position, in which it remains until the bin is substantially filled again.

[0014] The press plate exerts a force on the refuse in order to compact the refuse. If the bin contains a lot of refuse that has already been compacted several times the compactor unit may not be able to apply the force needed to reach its most extended position with the press plate substantially levelled. When in this situation the compactor unit reaches its maximum force it will retract into the retracted position.

[0015] In a preferred embodiment the lower pivot links have a horizontal position in between a pair of parallel spaced apart upper pivot links.

[0016] According to the invention the lower pivot links comprise one or more recesses into which in the upper retracted position the fifth and sixth pivot axis insert and/or the upper pivot links comprise one or more recesses into which in the retracted position the fourth and seventh pivot axis insert.

[0017] These recesses allow the hinged construction and press plate to be folded together to a larger extent and thus to obtain a more economic of space arrangement in the retracted position. In these embodiments the one more rear pivot links are connected at the above-mentioned seventh pivot axis to said one or more lower pivot links.

[0018] In some embodiments the press plate is not an entirely flat plate, but is somewhat rounded around an axis parallel to the first axis to be able to apply a larger pressing force and/or to obtain a more economic of size retracted position. In this case the angle of the press plate with respect to horizontal referred to above is the angle between horizontal and the plane through the fifth and sixth pivot axis.

[0019] In an embodiment the actuator is connected at one end to the one or more lower pivot links and the one or more rear pivot links are connected at the seventh pivot axis to the one or more lower pivot links. The lower pivot links are used to transmit a pressing force from the actuator to the press plate, while front pivot links and upper pivot links provide stability to the hinged construction. The one or more rear pivot links may be rounded between their two pivot axis to be able to withstand a large pressing force. Other embodiments of the invention may distribute the forces differently over the pivot links.

In other embodiments the actuator may be connected between the frame and a different part of the hinged construction, e.g. the upper pivot link or the rear pivot link, or between the frame and the press plate.

[0020] In a preferred embodiment the upper pivot links, the lower pivot links, the front pivot links and the rear pivot links each comprise a pair of pivot links spaced apart and parallel to each other. Optionally connection means such as connection rods interconnect the pair of pivot links to add stability to the hinged construction. These connection rods are preferably provided at ends of the upper pivot links, lower pivot links, front pivot links and rear pivot links, e.g. at the second pivot axis, the fourth pivot axis and/or the seventh pivot axis.

[0021] The frame of the compactor unit can be connected to a side face or to the top face of the housing. Preferably the frame is connected to the top face of the housing towards the rear face of the housing or to the rear face of the housing towards the top face. The frame may comprise one or more suspension elements extending downwards from the frame, at the ends of which the one or more upper pivot links and lower pivot links are connected.

[0022] The actuator may be a linear actuator, e.g. a cylinder-with-piston, e.g. hydraulic, or a spindle, e.g. an electric motor screw spindle.

[0023] The actuator may at one end be connected to the frame and at the other end connected to the one or more pivot links or directly to the press plate, preferably to the one or more lower pivot links.

[0024] In a preferred embodiment the motor is placed adjacent to and in front of the actuator, toward the front side of the housing, to achieve an economic of space retracted position.

[0025] The housing and compactor unit are preferably used with an exchangeable bin open at the top having a volume between 120-240 litres, but the same device with minor adjustments is expected to be useable with bins of larger or smaller volume. The length of the pivot links and the size of the press element can be adjusted so as to achieve good compaction. For example a bin with a volume of 120 litres has an opening at its top with a standard size of approximately 38 cm by 38 cm and the press plate for a bin of this volume has in a preferred embodiment a size of approximately 32 cm by 28 cm. Smaller or slightly larger press plate sizes are however also possible.

[0026] In a preferred embodiment the refuse collector and compactor device has a refuse insertion opening into which a lid with a handle is provided. In order to insert refuse into the device the lid is pulled or rotated outward from the housing using the handle. Refuse is then inserted, after which the lid is pivoted inwards again.

[0027] In a preferred embodiment the refuse collector and compactor device comprises an active or passive locking system to prevent simultaneous opening of the lid provided into the refuse insertion opening and operation of the press mechanism. The locking system thus

prevents the compactor unit from leaving the retracted position when the lid is open, while preventing the lid from opening when the compactor unit has started its downwards motion from the retracted to the pressing position.

[0028] In a preferred embodiment the press plate attains a tilted orientation in the retracted position with an angle upwards with respect to horizontal of between 10 and 80 degrees, preferably between 30 and 60 degrees.

[0029] In a preferred embodiment the press plate attains a substantially levelled orientation in the pressing position with a tilt upwards or downwards with respect to horizontal of between 0 and 30 degrees.

[0030] In a preferred embodiment the refuse collector and compactor device comprises a shield system that shields the assembly of links of the device, or at least a part thereof, from contact with and/or interference by the refuse. The shield system may be embodied to shield these elements of the device from contact with refuse at the moment that said refuse is inserted via the refuse insertion opening into a bin that is placed in the housing. The shield system may also shield these elements of the device from contact with said refuse during the compaction thereof, that is, during the pressing motion of the device. Such contact may arise in the absence of a shield system e.g. when during compression an item of refuse near a side of the housing is pushed on top of the press plate. The contact of refuse with these elements of the device other than the press plate and, if provided, the shield system, is likely to be detrimental to the functioning and durability of the device, as such refuse may e.g. end up between the pivotal links, e.g. close to a pivot axis, and subsequently prevent proper execution of the pressing motion. The provision of a shield system is therefore advantageous.

[0031] Said shield system may comprise a front plate provided to, e.g. secured onto and/or integrated with, the one or more front pivot links, e.g. at the front side thereof, e.g. with a bottom edge of the front plate substantially at the height of the fifth pivot axis and extending along said one or more front pivot links to an upper end of the front plate. Said upper end may for instance be provided substantially at the height of the fourth pivot axis. Said front plate preferably has a front plate width in a direction parallel to the first pivot axis between a left end and a right end that is equal to the width of the press plate, said press plate width being also in a direction parallel to the first pivot axis between a left and a right end.

[0032] Said shield system may, e.g. in addition to said front plate, comprise two press plate side plates provided to the press plate at respectively the left and right side thereof. Said press plate side plates preferably are raised from the respective side of the press plate, e.g. extend in a side plane perpendicular to the front face of the housing and perpendicular to the top face of the housing.

[0033] Said shield system may also comprise two front side shield plates that are joined to the front plate at the respectively the left and right end thereof. Said front side shield plates generally extend in a side plane, e.g. sub-

stantially perpendicular to the front face of the housing and perpendicular to the top face of the housing.

[0034] Whereas the front plate shields the linkage assembly of the collector and compactor device from refuse at the front side of said device, said side plates shield these elements from refuse at the sides.

[0035] in an embodiment comprising a shield system with a front plate, the fifth pivot axis is preferably provided at or near the front edge of the press plate. In an embodiment said shield system also comprises a bottom shield plate provided to said one or more front pivot links at a bottom end thereof. Said bottom plate extends along the lower end of the front pivot links from the front thereof substantially to the fifth pivot axis. In this way said bottom plate adjoins with its front end to the lower end of the front plate and adjoins with its rear end to the front edge of the press plate.

[0036] A plate member of the shield system may be formed by a closed surface plate, e.g. of steel, but may also be made of perforated plate material when desired or other non-closed surface members, e.g. a grating.

[0037] The present invention also relates to a combination of a refuse collector and compactor device according to the present invention and an exchangeable bin, e.g. arranged within the housing.

[0038] The present invention also relates to a method for collecting and compacting refuse, wherein use is made of a refuse collector and compactor device according to the present invention and wherein an exchangeable bin is arranged within the housing.

[0039] The invention will now be described with reference to the drawings.

Fig. 1 shows a side view of the refuse collector and compactor device according to the invention and an exchangeable bin,

Figs. 2-4 show the vertical motion and simultaneous change of tilting angle of the press plate of figure 1 from the retracted to the pressing position,

Fig 2 shows a side view of the refuse collector and compactor device in the retracted position,

Fig. 3 shows a side view of the refuse collector and compactor device in a position in between the retracted and pressing position,

Fig. 4 shows a side view of the refuse collector and compactor device in the pressing position.

Fig. 5 shows a side view of the passive locking system of the refuse collector and compactor device according to the invention with the lid provided in the refuse insertion opening in the front face of the housing being partly opened,

Fig. 6 shows a side view of the passive locking system of the refuse collector and compactor device according to the invention with said lid being closed,

Fig. 7 shows the passive locking system of the refuse collector and compactor device according to the invention from a different viewpoint,

Fig. 8 shows a view of the refuse collector and com-

packtor device with shield system according to the invention with the device in a retracted position,

Fig. 9 shows a view of the refuse collector and compactor device of figure 8 in an intermediate position in between the retracted position and the fully extended pressing position,

Fig. 10 shows another view of the refuse collector and compactor device as shown in figure 9.

[0040] With reference to the drawings embodiments and optional features of vertical refuse collector and compactor device according to the invention will be described.

[0041] The refuse collector and compactor device 101 comprises a housing 102 with a front face 1021, a top face 1023 and a rear face 1024. The front face 1021 has a refuse insertion opening 1022 into which a lid 1025 with a handle 1026 is provided. An open topped bin 105 is provided in the housing 102.

[0042] The compactor unit 103 comprises a frame 10301 attached to said housing 102. The frame may comprise one or more suspension elements 103011, here two spaced apart parallel suspension elements, extending mainly downwards.

[0043] The compactor unit furthermore comprises a pair of parallel spaced apart upper pivot links 10302, each connected at one end to one of the suspension elements 103011 at a first pivot axis 10303. The first pivot axis 10303 is a horizontal axis near the rear face of the housing.

[0044] The compactor unit further comprises a pair of parallel spaced apart front pivot links 10304, each connected to one upper pivot link 10302 at a second pivot axis 10305 provided at the end of the upper pivot link 10302 opposite the first pivot axis 10303. The second pivot axis 10305 is parallel to the first axis 10303.

[0045] The compactor unit further comprises a rectangular or square press plate 10306 connected at a fifth axis 10312 to the pair of front pivot links 10304. The fifth axis is parallel to the first axis.

[0046] The compactor unit further comprises a pair of parallel spaced apart lower pivot links 10307 parallel to the pair of upper pivot links 10302. Each lower pivot link is connected to one of the suspension elements at a third pivot axis 10308 provided below the first pivot axis 10303. The third pivot axis 10308 is parallel to the first pivot axis 10303.

[0047] The lower pivot links may have a horizontal position within the pair of upper pivot links as shown most clearly in figures 3-4.

[0048] Each lower pivot link 10307 is connected at its end opposite the third pivot axis 10308 to one of the front pivot links 10304 at a fourth axis 10309. The fourth axis 10309 is provided on the front pivot link 10304 between the second axis 10305 and the fifth axis 10312. The fourth axis 10309 is parallel to the first axis 10303.

[0049] The compactor unit 103 further comprises a pair of parallel spaced apart rear pivot links 10313, each con-

nected at one end to one of the lower pivot links 10307 at a seventh axis 10315 provided on each of said lower pivot links 10307 between the fourth axis 10309 and the third axis 10308. The seventh axis 10315 is parallel to the first axis 10303.

[0050] Each rear pivot link 10313 is connected at its end opposite the seventh axis 10315 to the press plate at a sixth axis 10314. The sixth axis 10314 is parallel to the first axis 10303.

[0051] The compactor unit 103 further comprises a cylinder-with-piston 10310 comprising a cylinder 10310a and a piston 10310b. The cylinder 10310a is connected to the frame 10301, while the piston 10310b is connected at an axis 103101 on the lower pivot links 10307 at a position thereof between the seventh axis 10315 and the third axis 10308. The axis 103101 is parallel to the first axis 10303.

[0052] The compactor unit 103 further comprises a motor 10311 to drive said actuator. The motor 10311 is connected to the frame 10301 and provided in front of the cylinder 10310a.

[0053] The press plate 10306 and the hinged construction, formed by the upper pivot links 10302, lower pivot links 10307, front pivot links 10304 and rear pivot links 10313, are shown in figure 9 in substantially the pressing position with the hinged construction at an extension close to the maximum extension it is adapted to attain and with the press plate 10306 substantially levelled.

[0054] The upper pivot links 10302 and the lower pivot links 10307 contain recesses 10316 into which in the retracted position the pivotal connections at the fourth 10309, fifth 10312, sixth 10314 and seventh 10315 pivot axis insert. In the shown embodiment the rear pivot links 10313 have a curved shape along the longitudinal direction.

[0055] Connection rods 10317, shown in figures 1 - 4, interconnect the pair of parallel upper pivot links and the pair of front pivot links at the second pivot axis 10305, the pair of parallel lower pivot links and the pair of front pivot links at the fourth pivot axis 10309 and the pair of parallel lower pivot links and the pair of rear pivot links at the seventh pivot axis 10315.

[0056] With reference to figures 2-4 the vertical motion and simultaneous change of tilting angle of the press plate from the retracted to the pressing position will be described.

[0057] Figure 2 shows the compactor unit in the retracted position. The upper pivot links 10302 are tilted toward the top of the housing and the angle between upper pivot links and front pivot links is small, e.g. approximately 10 degrees. The press plate is tilted at an angle with respect to the horizontal that is substantially the same as the angle of the upper pivot links with respect to the horizontal. The piston 10310b is also retracted.

[0058] As will be apparent from figures 3 and especially 4 in the shown embodiment the distance between the fourth pivot axis 10309 and the fifth pivot axis 10312 equals the distance between the seventh 10315 and the

sixth pivot 10314 axis, so that the angle of the press plate with respect to horizontal equals the angle of the upper pivot links to the horizontal.

[0059] In figure 3 a stroke of the piston 10310b of the cylinder-with-piston 10310 has moved to upper pivot links 10302, lower pivot links 10307, front pivot links 10304 and rear pivot links 10313 to a partially unfolded position in between the retracted position of figure 10 and the pressing position of figure 12.

[0060] In figure 4 the stroke of the piston 10310b of the cylinder-with-piston 10310 has moved the upper pivot links 10302, lower pivot links 10307, front pivot links 10304 and rear pivot links 10313 to its maximally unfolded position, the pressing position. The angle between the upper pivot links and the front pivot links is large, e.g. approximately 90 degrees. In this position the press plate is expected to be in contact with refuse and is expected to be pushing the refuse downwards.

[0061] In the shown embodiment the upper pivot links 10302 and the lower pivot links 10307 are substantially levelled, while the front pivot links 10304 and rear pivot links 10313 extend substantially in the vertical direction. The press plate 10306 is substantially parallel to the upper pivot links 10302 and lower pivot links 10307 and thus also substantially levelled. The piston 10310b of the cylinder-with-piston 10310 is at its maximum extension.

[0062] With reference to figures 5-7 an embodiment of the passive locking system 104 will now be described.

[0063] The lid 1025 provided in the front face 1021 of the housing 102 comprises a front face 10251 at the position of the refuse insertion opening 1022 and two side faces 10252. In order to insert refuse to the device the lid 1025 is pulled or rotated outwards from the housing using the handle 1026. Refuse is then inserted, after which the lid 1025 is pushed inwards again.

[0064] The passive locking system 104 comprises a cap 1040 that partially covers in the retracted position the upper ends of the one or more upper pivot links and front pivot links at the site of the second pivot axis 10305. The cap 1040 covers the upper pivot links and front pivot links at the site of the second pivot axis at the top and sides. The cap 1040 comprises a front face 1042, into which recesses 1041, shown in figure 15, are provided at the outer ends. The side faces 10252 of the lid 1025 can partly insert into said recesses 1041.

[0065] When the lid 1025 is closed the cap 1040 is located above the lid and is not in contact with the lid 1040 as shown in figure 5.

[0066] When the lid 1025 is opened the side faces of the lid 10252 move forward and partly insert into the recesses 1041 in the front face 1042 of the cap as shown in figure 6. The downward motion of the pressing unit requires the upper pivot links 10302 to perform a rotation that in the initial stage of this downward movement moves the upper end of the upper pivot links near the second pivot axis 10305 toward the front face 1021 of the housing 102. The cap 1040 surrounding the upper pivot links 10302 should therefore move forward together with the

pivot links, e.g. by a pivotable and/or extendable connection of the cap 1040 to the frame 10301. When the lid 1025 is opened the motion of the cap 1040 in this forward direction is however prevented, as the side faces 10252 of the lid 1025 press against the front face 1042 of the cap 1040. Therefore the upper pivot links 10302 cannot perform the required rotation and the compactor unit is locked in the storage position.

[0067] When the lid is completely closed the compactor unit can start its movement from the storage to the pressing position by pushing the cap 1040 that surrounds the upper end of the upper pivot links closer toward the front face 1021 of the housing 102. When trying to open the lid after the cap 1040 has moved forward the side faces 10252 of the lid 1025 come into contact with the front face 1042 of the cap 1040, thereby preventing further outward movement of the lid 1025. In this way the cap 1040 prevents the lid 1025 from being opened when the compactor unit is not in the storage position.

[0068] With reference to figures 8-10 an embodiment of the refuse collector and compactor device provided with a shield system 106 will now be described. In general the structure and operation of the device is the same as described above and will not be discussed again. As explained the shield system serves as a mechanical shield that prevents refuse from reaching the assembly of links and related pivots of the device, e.g. as someone deposits refuse into the device via the opening thereof. The shield system enhances the operational reliability of the device.

[0069] The shield system 106 comprises a front plate 1061 that is provided to the pair of spaced apart parallel front pivot links 10304, here provided to the front side of the pair of spaced apart parallel front pivot links 10304. Said front plate 1061 here interconnects the pair of front pivot links 10304.

[0070] The front plate 1061 extends laterally over a width substantially equal to the width of the press plate. The width of both the front plate 1061 and the press plate here correspond to a dimension parallel to the first pivot axis 10303. The press plate and front plate each extend along said direction parallel to the first pivot axis 10303 between a left end and a right end.

[0071] The front plate 1061 has a bottom end that is provided substantially at the height of the fifth pivot axis 10312 and extends along said one or more front pivot links 10304 to an upper end, e.g. said upper end being substantially at the height of the fourth pivot axis 10309. Said front 1061 thus extends along at least a portion of the front pivot links 10304, and possibly extends along the full length of the front pivot links 10304 between the height of the second pivot axis 10305 and the height of the fifth pivot axis 10312.

[0072] The shield system 106 moreover comprises side plates 1062 provided to the left end and the right end of the press plate. Said side plates 1062 here each extend in a side plane perpendicular to the front face of the housing and perpendicular to the top face of the hous-

ing.

[0073] Moreover, the front plate 1061 is joined to front side shield plates 1063 which are provided to the left end and the right end of the front plate. Similarly to the press plate side plates 1062 said front side shield plates 1063 here each extend in a side plane perpendicular to the front face of the housing and perpendicular to the top face of the housing.

[0074] The front side shield plates 1063 are here provided at the extreme left and right end of said front plate 1061, while the press plate side plates 1062, while also provided substantially at the left and right end of said press plate 10306, are provided slightly inwards with respect to the front side shield plates 1063, so that front side shield plate 1063 and press plate side plate 1062 are slightly offset, thereby allowing these adjacent press plate side plates 1062 and front side shield plates 1063 to overlap when viewed from the side. Said overlap avoids a gap between said shielding plates from arising in the retracted position, in the pressing position or in any position intermediate these position.

[0075] In the embodiment of figures 8-10 the fifth pivot axis 10312 is provided at the edge of the press plate 10306 that is closest to the front face of the housing. In such an embodiment the shield system 106 may also comprise a bottom plate 1064 that serves to avoid the occurrence of a gap between the front plate 1061 and the press plate 10306. Said bottom plate 1064 is provided to said one or more front pivot links 10304 at a bottom end thereof and extends along the lower end of the front pivot links 10304 from the front thereof substantially to the fifth pivot axis 10312. In this way the bottom plate 1064 adjoins with its front end to the lower end of the front plate 1061 and adjoins with its rear end to the front edge of the press plate 10306.

[0076] The front plate 1061 and bottom plate 1064, optionally also the front plate side plates 1063, may be joined to form an integral structure.

[0077] In the embodiment of figures 8-10 the press plate 10306 comprises a rearmost section of which the tilt is, as in previous embodiments, equal to the tilt of the upper pivot links 10302. The press plate 10306 moreover comprises a section forward of said rearmost section with a slightly more downward orientation, followed by a section having a more upward orientation. Said sections allow for a more compact collector and compactor device in the retracted position. The overall tilt of the press plate 10306 in the embodiment of figures 8-10 is however still substantially equal to the tilt of the upper pivot links 10302.

Claims

1. A refuse collector and compactor device (101) comprising:

- a housing (102) to hold an exchangeable open

topped bin (105), said housing having a front face (1021) with a refuse insertion opening (1022), a rear face (1024) and a top face (1023),
- a compactor unit (103) comprising:

- a frame (10301) attached to said housing (102),
- one or more upper pivot links (10302), said one or more upper pivot links at one end connected to the frame at first pivot axis (10303), said first pivot axis being a horizontal axis near the rear face of the housing,
- one or more front pivot links (10304), said one or more front pivot links connected at a second pivot axis (10305) to said one or more upper pivot links (10302), said second pivot axis being at the end of the upper pivot link opposite the first pivot axis and parallel to the first pivot axis,
- a press element (10306) connected to said one or more front pivot links at the ends thereof opposite the second pivot axis,
- one or more lower pivot links (10307), substantially parallel to the one or more upper pivot links, said one or more lower pivot links at one end connected to the frame at a third pivot axis (10308), said third pivot axis being below the first pivot axis and parallel to the first pivot axis, said one or more lower pivot links connected to the one or more front pivot links at a fourth pivot axis (10309), said fourth pivot axis being at the end of the lower pivot link opposite the first pivot axis and parallel to the first pivot axis,
- an actuator (10310) adapted to impart to the press element a vertical motion from an upper retracted position, in which the upper pivot links tilt toward the top of the housing, to a lower pressing position and vice versa for compacting refuse,

wherein the press element is a press plate (10306) connected to the front pivot links at a fifth pivot axis (10312), said fifth pivot axis parallel to the first pivot axis,

wherein the compactor unit further comprises one or more rear pivot links (10313), substantially parallel to the front pivot links, said one or more rear pivot links connected at one end to said press plate at a sixth pivot axis (10314), said sixth pivot axis parallel to the first pivot axis and offset toward the rear face of the housing with respect to the fifth pivot axis, said one or more rear pivot links connected at a seventh pivot axis (10315) to said one or more lower pivot links, said seventh axis being at the end of the rear pivot link opposite the sixth pivot axis and parallel to the first pivot axis, said one or more

rear pivot links adapted to impart to the press plate a motion from a tilted orientation in the upper retracted position, with the edge of the press plate (10306) closest to the front face of the housing elevated with respect to the edge near the rear face of the housing, to a substantially levelled orientation in the lower pressing position, **characterized in that** the compactor unit (103) comprises a motor (10311) to drive said actuator, and

in that said lower pivot links comprise one or more recesses into which in the upper retracted position the fifth and sixth pivot axis insert, and/or

in that said upper pivot links (10302) comprise one or more recesses into which in the retracted position the fourth (10309) and seventh (10315) pivot axis insert.

2. A refuse compactor device according to claim 1, wherein the distance between the fourth pivot axis and the fifth pivot axis equals the distance between the seventh and the sixth pivot axis, so that the tilt of the press plate is substantially equal to the tilt of the upper pivot links.
3. A refuse collector and compactor device according to claim 1 or 2, wherein the lower pivot links (10307) have a horizontal position in between a pair of parallel spaced apart upper pivot links (10302).
4. A refuse collector and compactor according to any of the preceding claims, wherein at least one, e.g. all, of the upper pivot links, front pivot links, lower pivot links and rear pivot links is a pair of spaced apart parallel pivot links.
5. A refuse collector and compactor according to claim 4, wherein the upper pivot links, front pivot links, lower pivot links and rear pivot links are a pair of spaced apart parallel pivot links and one or more of the pairs of upper pivot links, lower pivot links, front pivot links and rear pivot links are interconnected by connection means, e.g. connection rods, preferably placed at the second pivot axis, the fourth pivot axis and/or the seventh pivot axis.
6. A refuse collector and compactor device according to any of the preceding claims, wherein said press plate (10306) has a press plate width in a direction parallel to the first pivot axis between a left end and a right end of said press plate and wherein said refuse collector and compactor device further comprises a shield system (106) comprising a front plate (1061), wherein said front plate is provided to said one or more front pivot links (10304), e.g. provided to said one or more front pivot links at the front side thereof, wherein the front plate has a front plate width

in a direction substantially parallel to the first pivot axis (10303) between a left end and a right end of said front plate that is preferably substantially equal to the press plate width, wherein said front plate has a bottom end substantially at the height of the fifth pivot axis and extends along said one or more front pivot links to an upper end, e.g. said upper end being substantially at the height of the fourth pivot axis.

7. A refuse collector and compactor according to claim 6, wherein the shield system further comprises two press plate side plates (1062) provided to the press plate at respectively the left and right side thereof, each press plate side plate preferably extending in a side plane perpendicular to the front face of the housing and perpendicular to the top face of the housing, and wherein the shield system further comprises two front side shield plates (1063) joined to the front plate at or near respectively the left and right end thereof, each front side shield plate preferably extending in a side plane perpendicular to the front face and perpendicular to the top face of the housing.
8. A refuse collector and compactor according to claim 6 or 7, wherein said fifth pivot axis is provided substantially at the front edge of the press plate and wherein the shield system further comprises a bottom plate (1064), said bottom plate provided to said one or more front pivot links at a bottom end thereof and extending along the lower end of the front pivot links from the front thereof substantially to the fifth pivot axis, so that said bottom plate adjoins with its front end to the lower end of the front plate and adjoins with its rear end to the front edge of the press plate.
9. A refuse collector and compactor device according to any of the preceding claims, wherein the actuator is a linear actuator, preferably a cylinder-with-piston (10310), at one end connected to the frame and at the other end connected to one or more of the pivot links or directly to the press plate (10306), preferably to the one or more lower pivot links, wherein optionally the motor (10311) is placed adjacent to the linear actuator and toward the front face of the housing.
10. A refuse collector and compactor device according to any of the preceding claims, further comprising a lid (1025) provided in the refuse insertion opening and a passive locking system (104) that prevents opening of the lid when the compactor unit is not in the retracted position, wherein optionally said passive locking system also prevents motion of the compactor unit when the lid is opened.
11. A refuse collector and compactor device according to any of the preceding claims, wherein the press

plate (10306) attains a tilted orientation in the retracted position with an angle upwards with respect to horizontal of between 10 and 80 degrees, preferably between 30 and 60 degrees.

12. A refuse collector and compactor device according to any of the preceding claims, wherein the press plate (10306) attains a substantially levelled orientation in the pressing position with a tilt upwards or downwards with respect to horizontal of between 0 and 30 degrees.
13. In combination a refuse collector and compactor device (101) according to any of the preceding claims and an exchangeable bin (105), e.g. arranged within the housing.
14. A method for collecting and compacting refuse, wherein use is made of a refuse collector and compactor device according to any of the preceding claims, and wherein an exchangeable bin (105) is arranged within the housing.

25 Patentansprüche

1. Abfallsammel- und Verdichtungsvorrichtung (101), umfassend:
- ein Gehäuse (102), um einen austauschbaren, oben offenen Behälter (105) zu halten, wobei das Gehäuse eine Vorderseite (1021) mit einer Abfallsammelöffnung (1022), eine Rückseite (1024) und eine Oberseite (1023) aufweist,
 - eine Verdichtungseinheit (103), umfassend:
 - einen Rahmen (10301), der an dem Gehäuse (102) angebracht ist,
 - ein oder mehrere obere Schwenkglieder (10302), wobei das eine oder die mehreren oberen Schwenkglieder an einem Ende mit dem Rahmen an einer ersten Schwenkachse (10303) verbunden sind, wobei die erste Schwenkachse eine horizontale Achse in der Nähe der Rückseite des Gehäuses ist,
 - ein oder mehrere vordere Schwenkglieder (10304), wobei das eine oder die mehreren vorderen Schwenkglieder an einer zweiten Schwenkachse (10305) mit dem einen oder den mehreren oberen Schwenkgliedern (10302) verbunden sind, wobei sich die zweite Schwenkachse an dem Ende des oberen Schwenkglieds befindet, das der ersten Schwenkachse gegenüberliegt und parallel zu der ersten Schwenkachse verläuft,
 - ein Presselement (10306), das mit dem einen oder den mehreren vorderen

Schwenkgliedern an deren Enden gegenüber der zweiten Schwenkachse verbunden ist,

- ein oder mehrere untere Schwenkglieder (10307), die im Wesentlichen parallel zu dem einen oder den mehreren oberen Schwenkgliedern sind, wobei das eine oder die mehreren unteren Schwenkglieder an einem Ende mit dem Rahmen an einer dritten Schwenkachse (10308) verbunden sind, wobei die dritte Schwenkachse unterhalb der ersten Schwenkachse und parallel zu der ersten Schwenkachse liegt, wobei das eine oder die mehreren unteren Schwenkglieder mit dem einen oder den mehreren vorderen Schwenkgliedern an einer vierten Schwenkachse (10309) verbunden sind, wobei die vierte Schwenkachse an dem Ende des unteren Schwenkglieds gegenüber der ersten Schwenkachse und parallel zu der ersten Schwenkachse liegt,

- einen Aktuator (10310), der geeignet ist, dem Presselement eine vertikale Bewegung von einer oberen eingefahrenen Position, in der die oberen Schwenkglieder zu der Oberseite des Gehäuses hin kippen, zu einer unteren Pressposition und umgekehrt zum Verdichten von Müll zu verleihen,

wobei das Presselement eine Pressplatte (10306) ist, die mit den vorderen Schwenkgliedern an einer fünften Schwenkachse (10312) verbunden ist, wobei die fünfte Schwenkachse parallel zu der ersten Schwenkachse verläuft, wobei die Verdichtungseinheit darüber hinaus ein oder mehrere hintere Schwenkglieder (10313) umfasst, die im Wesentlichen parallel zu den vorderen Schwenkgliedern verlaufen, wobei das eine oder die mehreren hinteren Schwenkglieder an einem Ende mit der Pressplatte an einer sechsten Schwenkachse (10314) verbunden sind, wobei die sechste Schwenkachse parallel zu der ersten Schwenkachse verläuft und in Bezug auf die fünfte Schwenkachse in Richtung der Rückseite des Gehäuses versetzt ist, wobei das eine oder die mehreren hinteren Schwenkglieder an einer siebten Schwenkachse (10315) mit dem einen oder den mehreren unteren Schwenkgliedern verbunden sind, wobei sich die siebte Achse an dem Ende des hinteren Schwenkgliedes befindet, das der sechsten Schwenkachse gegenüberliegt und parallel zu der ersten Schwenkachse verläuft, wobei das eine oder die mehreren hinteren Schwenkglieder so ausgelegt sind, dass sie der Pressplatte eine Bewegung aus einer gekippten Ausrichtung in der oberen eingefahrenen Position, wobei die Kante der Pressplatte (10306),

die der Vorderseite des Gehäuses am nächsten ist, in Bezug auf die Kante nahe der Rückseite des Gehäuses erhöht ist, in eine im Wesentlichen nivellierte Ausrichtung in der unteren Pressposition verleihen,

dadurch gekennzeichnet, dass die Verdichtungseinheit (103) einen Motor (10311) zum Antreiben des Aktuators umfasst, und dass die unteren Schwenkglieder eine oder mehrere Aussparungen umfassen, in die in der oberen eingefahrenen Position die fünfte und sechste Schwenkachse eingreifen, und/oder dass die oberen Schwenkglieder (10302) eine oder mehrere Aussparungen umfassen, in die in der eingefahrenen Position die vierte (10309) und siebte (10315) Schwenkachse eingreifen.

2. Abfallsammel- und Verdichtungsrichtung nach Anspruch 1, wobei der Abstand zwischen der vierten Schwenkachse und der fünften Schwenkachse gleich dem Abstand zwischen der siebten und der sechsten Schwenkachse ist, so dass die Neigung der Pressplatte im Wesentlichen gleich der Neigung der oberen Schwenkglieder ist.
3. Abfallsammel- und Verdichtungsrichtung nach Anspruch 1 oder 2, wobei die unteren Schwenkglieder (10307) eine horizontale Position zwischen einem Paar paralleler, voneinander beabstandeter oberer Schwenkglieder (10302) einnehmen.
4. Abfallsammel- und Verdichtungsrichtung nach einem der vorhergehenden Ansprüche, wobei mindestens eines, z.B. alle, der oberen Schwenkglieder, vorderen Schwenkglieder, unteren Schwenkglieder und hinteren Schwenkglieder ein Paar von beabstandeten parallelen Schwenkglieder ist.
5. Abfallsammel- und Verdichtungsrichtung nach Anspruch 4, wobei die oberen Schwenkglieder, die vorderen Schwenkglieder, die unteren Schwenkglieder und die hinteren Schwenkglieder ein Paar von beabstandeten parallelen Schwenkgliedern sind und eines oder mehrere der Paare von oberen Schwenkgliedern, unteren Schwenkgliedern, vorderen Schwenkgliedern und hinteren Schwenkgliedern durch Verbindungsmittel, z. B. Verbindungsstangen, miteinander verbunden sind, die vorzugsweise an der zweiten Schwenkachse, der vierten Schwenkachse und/oder der siebten Schwenkachse angeordnet sind.
6. Abfallsammel- und Verdichtungsrichtung nach einem der vorhergehenden Ansprüche, wobei die Pressplatte (10306) eine Pressplattenbreite in einer Richtung parallel zu der ersten Schwenkachse zwischen einem linken Ende und einem rechten Ende der Pressplatte aufweist und wobei die Ab-

- fallsammel- und Verdichtungsvorrichtung darüber hinaus ein Abschirmsystem (106) umfasst, das eine Frontplatte (1061) umfasst, wobei die Frontplatte an dem einen oder den mehreren vorderen Schwenkgliedern (10304) vorgesehen ist, z.B. an dem einen oder den mehreren vorderen Schwenkgliedern an der Vorderseite davon vorgesehen ist, wobei die Frontplatte eine Frontplattenbreite in einer Richtung im Wesentlichen parallel zu der ersten Schwenkachse (10303) zwischen einem linken Ende und einem rechten Ende der Frontplatte aufweist, die vorzugsweise im Wesentlichen gleich der Pressplattenbreite ist, wobei die Frontplatte ein unteres Ende im Wesentlichen auf der Höhe der fünften Schwenkachse aufweist und sich entlang des einen oder der mehreren vorderen Schwenkglieder zu einem oberen Ende erstreckt, wobei z.B. das obere Ende im Wesentlichen auf der Höhe der vierten Schwenkachse liegt.
7. Abfallsammel- und Verdichtungsvorrichtung nach Anspruch 6, wobei das Abschirmsystem darüber hinaus zwei Pressplattenseitenplatten (1062) umfasst, die an der Pressplatte an deren linker bzw. rechter Seite vorgesehen sind, wobei sich jede Pressplattenseitenplatte vorzugsweise in einer Seitenebene senkrecht zu der Vorderseite des Gehäuses und senkrecht zu der Oberseite des Gehäuses erstreckt, und wobei das Abschirmsystem darüber hinaus zwei Vorderseitenabschirmplatten (1063) umfasst, die mit der Frontplatte an oder nahe deren linkem bzw. rechtem Ende verbunden sind, wobei sich jede Vorderseitenabschirmplatte vorzugsweise in einer Seitenebene senkrecht zu der Vorderseite und senkrecht zu der Oberseite des Gehäuses erstreckt.
8. Abfallsammel- und Verdichtungsvorrichtung nach Anspruch 6 oder 7, wobei die fünfte Schwenkachse im Wesentlichen an der Vorderkante der Pressplatte vorgesehen ist, und wobei das Abschirmsystem darüber hinaus eine Bodenplatte (1064) umfasst, wobei die Bodenplatte an dem einen oder den mehreren vorderen Schwenkgliedern an deren unterem Ende vorgesehen ist und sich entlang des unteren Endes der vorderen Schwenkglieder von deren Vorderseite im Wesentlichen zu der fünften Schwenkachse erstreckt, so dass die Bodenplatte mit ihrem vorderen Ende an das untere Ende der Frontplatte angrenzt und mit ihrem hinteren Ende an die Vorderkante der Pressplatte angrenzt.
9. Abfallsammel- und Verdichtungsvorrichtung nach einem der vorhergehenden Ansprüche, wobei der Aktuator ein Linearaktuator, vorzugsweise ein Zylinder mit Kolben (10310), ist, der an einem Ende mit dem Rahmen und an dem anderen Ende mit einem oder mehreren der Schwenkglieder oder direkt mit der Pressplatte (10306), vorzugsweise mit dem einen oder den mehreren unteren Schwenkgliedern, verbunden ist, wobei optional der Motor (10311) neben dem Linearaktuator und in Richtung der Vorderseite des Gehäuses angeordnet ist.
10. Abfallsammel- und Verdichtungsvorrichtung nach einem der vorhergehenden Ansprüche, die darüber hinaus einen in der Abfallsammelöffnung vorgesehenen Deckel (1025) und ein passives Verriegelungssystem (104) umfasst, das ein Öffnen des Deckels verhindert, wenn sich die Verdichtungseinheit nicht in der eingefahrenen Position befindet, wobei das passive Verriegelungssystem optional auch eine Bewegung der Verdichtungseinheit verhindert, wenn der Deckel geöffnet ist.
11. Abfallsammel- und Verdichtungsvorrichtung nach einem der vorhergehenden Ansprüche, wobei die Pressplatte (10306) in der eingefahrenen Position eine Neigung mit einem Winkel nach oben gegenüber der Horizontalen zwischen 10 und 80 Grad, vorzugsweise zwischen 30 und 60 Grad, einnimmt.
12. Abfallsammel- und Verdichtungsvorrichtung nach einem der vorhergehenden Ansprüche, wobei die Pressplatte (10306) in der Pressposition eine im Wesentlichen ebene Ausrichtung mit einer Neigung nach oben oder unten gegenüber der Horizontalen zwischen 0 und 30 Grad annimmt.
13. Kombination aus einer Abfallsammel- und Verdichtungsvorrichtung (101) nach einem der vorhergehenden Ansprüche und einem austauschbaren Behälter (105), der z. B. innerhalb des Gehäuses angeordnet ist.
14. Verfahren zum Sammeln und Verdichten von Abfall, wobei eine Abfallsammel- und Verdichtungsvorrichtung nach einem der vorhergehenden Ansprüche verwendet wird, und wobei ein austauschbarer Behälter (105) innerhalb des Gehäuses angeordnet ist.
- Revendications**
1. Dispositif de compactage et de collecte d'ordures (101) comprenant :
- un logement (102) pour contenir un compartiment à partie supérieure ouverte échangeable (105), ledit logement ayant une face avant (1021) avec une ouverture d'insertion d'ordures (1022), une face arrière (1024) et une face supérieure (1023),
- une unité de compactage (103) comprenant :
- un bâti (10301) fixé sur ledit logement

(102),

- une ou plusieurs liaisons de pivot supérieures (10302), lesdites une ou plusieurs liaisons de pivot supérieures étant raccordées, au niveau d'une extrémité, au bâti à un premier axe de pivot (10303), ledit premier axe de pivot étant un axe horizontal à proximité de la face arrière du logement,

- une ou plusieurs liaisons de pivot avant (10304), lesdites une ou plusieurs liaisons de pivot avant étant raccordées à un deuxième axe de pivot (10305), auxdites une ou plusieurs liaisons de pivot supérieures (10302), ledit deuxième axe de pivot étant à l'extrémité de la liaison de pivot supérieure, opposé au premier axe de pivot et parallèle au premier axe de pivot,

- un élément de presse (10306) raccordé auxdites une ou plusieurs liaisons de pivot avant au niveau de ses extrémités opposées au deuxième axe de pivot,

- une ou plusieurs liaisons de pivot inférieures (10307) sensiblement parallèles aux une ou plusieurs liaisons de pivot supérieures, lesdites une ou plusieurs liaisons de pivot inférieures étant raccordées, au niveau d'une extrémité, au bâti à un troisième axe de pivot (10308), ledit troisième axe de pivot étant au-dessous du premier axe de pivot et parallèle au premier axe de pivot, lesdites une ou plusieurs liaisons de pivot inférieures étant raccordées aux une ou plusieurs liaisons de pivot avant à un quatrième axe de pivot (10309), ledit quatrième axe de pivot étant à l'extrémité de la liaison de pivot inférieure opposée au premier axe de pivot et parallèle au premier axe de pivot,

- un actionneur (10310) adapté pour communiquer à l'élément de presse, un mouvement vertical allant d'une position rétractée supérieure, dans laquelle les liaisons de pivot supérieures s'inclinent vers le dessus du logement, jusqu'à une position de pression inférieure et vice versa pour compacter les ordures,

dans lequel l'élément de presse est une plaque de presse (10306) raccordée aux liaisons de pivot avant à un cinquième axe de pivot (10312), ledit cinquième axe de pivot étant parallèle au premier axe de pivot,

dans lequel l'unité de compactage comprend en outre une ou plusieurs liaisons de pivot arrière (10313), sensiblement parallèles aux liaisons de pivot avant, lesdites une ou plusieurs liaisons de pivot arrière étant raccordées, au niveau d'une extrémité, à ladite plaque de presse à un sixième axe de pivot (10314), ledit sixième axe

de pivot étant parallèle au premier axe de pivot et décalé vers la face arrière du logement par rapport au cinquième axe de pivot, lesdites une ou plusieurs liaisons de pivot arrière étant raccordées à un septième axe de pivot (10315) auxdites une ou plusieurs liaisons de pivot inférieures, ledit septième axe étant au niveau de l'extrémité de la liaison de pivot arrière opposé au sixième axe de pivot et parallèle au premier axe de pivot, lesdites une ou plusieurs liaisons de pivot arrière étant adaptées pour communiquer à la plaque de presse un mouvement à partir d'une orientation inclinée dans la position rétractée supérieure, avec le bord de la plaque de presse (10306) le plus proche de la face avant du logement levé par rapport au bord à proximité de la face arrière du logement, jusqu'à une orientation sensiblement de niveau dans la position de pression inférieure, **caractérisé en ce que** l'unité de compactage (103) comprend un moteur (10311) pour entraîner ledit actionneur, et

en ce que lesdites liaisons de pivot inférieures comprennent un ou plusieurs évidements dans lesquels, dans la position rétractée supérieure, les cinquième et sixième axes de pivot s'insèrent, et/ou

en ce que lesdites liaisons de pivot supérieures (10302) comprennent un ou plusieurs évidements dans lesquels, dans la position rétractée, le quatrième (10309) et le septième (10315) axe de pivot s'insèrent.

2. Dispositif de compactage d'ordures selon la revendication 1, dans lequel la distance entre le quatrième axe de pivot et le cinquième axe de pivot est égale à la distance entre le septième et le sixième axe de pivot, de sorte que l'inclinaison de la plaque de presse est sensiblement égale à l'inclinaison des liaisons de pivot supérieures.
3. Dispositif de compactage et de collecte d'ordures selon la revendication 1 ou 2, dans lequel les liaisons de pivot supérieures (10307) ont une position horizontale entre une paire de liaisons de pivot supérieures (10302) parallèles espacées.
4. Dispositif de compactage et de collecte d'ordures selon l'une quelconque des revendications précédentes, dans lequel au moins l'une, par exemple toutes, parmi les liaisons de pivot supérieures, les liaisons de pivot avant, les liaisons de pivot inférieures et les liaisons de pivot arrière est une paire de liaisons de pivot parallèles espacées.
5. Dispositif de compactage et de collecte d'ordures selon la revendication 4, dans lequel les liaisons de pivot supérieures, les liaisons de pivot avant, les

- liaisons de pivot inférieures et les liaisons de pivot arrière sont une paire de liaisons de pivot parallèles espacées et une ou plusieurs des paires de liaisons de pivot supérieures, de liaisons de pivot inférieures, de liaisons de pivot avant et de liaisons de pivot arrière sont interconnectées par un moyen de raccordement, par exemple des tiges de raccordement, de préférence placées au niveau du deuxième axe de pivot, du quatrième axe de pivot et/ou du septième axe de pivot.
- 5
- 10
6. Dispositif de compactage et de collecte d'ordures selon l'une quelconque des revendications précédentes, dans lequel ladite plaque de presse (10306) a une largeur de plaque de presse dans une direction parallèle au premier axe de pivot entre une extrémité gauche et une extrémité droite de ladite plaque de presse et dans lequel ledit dispositif de compactage et de collecte d'ordures comprend en outre un système de protection (106) comprenant une plaque avant (1061), dans lequel ladite plaque avant est prévue sur lesdites une ou plusieurs liaisons de pivot avant (10304), par exemple prévue sur lesdites une ou plusieurs liaisons de pivot avant au niveau de son côté avant, dans lequel la plaque avant a une largeur de plaque avant dans une direction sensiblement parallèle au premier axe de pivot (10303) entre une extrémité gauche et une extrémité droite de ladite plaque avant qui est de préférence sensiblement égale à la largeur de plaque de presse, dans lequel ladite plaque avant a une extrémité inférieure sensiblement à la hauteur du cinquième axe de pivot et s'étend le long desdites une ou plusieurs liaisons de pivot avant jusqu'à une extrémité supérieure, par exemple ladite extrémité supérieure étant sensiblement à la hauteur du quatrième axe de pivot.
- 15
- 20
- 25
- 30
- 35
7. Dispositif de compactage et de collecte d'ordures selon la revendication 6, dans lequel le système de protection comprend en outre deux plaques latérales de plaque de presse (1062) prévues sur la plaque de presse respectivement au niveau de son côté gauche et droit, chaque plaque latérale de plaque de presse s'étendant de préférence dans un plan latéral perpendiculaire à la face avant du logement et perpendiculaire à la face supérieure du logement, et dans lequel le système de protection comprend en outre deux plaques de protection du côté avant (1063) assemblées à la plaque avant au niveau de ou respectivement à côté de son extrémité gauche et droite, chaque plaque de protection du côté avant s'étendant de préférence dans un plan latéral perpendiculaire à la face avant et perpendiculaire à la face supérieure du logement.
- 40
- 45
- 50
8. Dispositif de compactage et de collecte d'ordures selon la revendication 6 ou 7, dans lequel ledit cinquième axe de pivot est prévu sensiblement au niveau du bord avant de la plaque de presse et dans lequel le système de protection comprend en outre une plaque inférieure (1064), ladite plaque inférieure étant prévue sur lesdites une ou plusieurs liaisons de pivot avant au niveau de son extrémité inférieure et s'étendant le long de l'extrémité inférieure des liaisons de pivot avant à partir de sa partie avant sensiblement jusqu'au cinquième axe de pivot, de sorte que ladite plaque inférieure est attenante avec son extrémité avant, à l'extrémité inférieure de la plaque avant et est attenante avec son extrémité arrière, au bord avant de la plaque de presse.
9. Dispositif de compactage et de collecte d'ordures selon l'une quelconque des revendications précédentes, dans lequel l'actionneur est un actionneur linéaire, de préférence un cylindre avec un piston (10310), au niveau d'une extrémité, raccordé au bâti et au niveau de l'autre extrémité, raccordé aux une ou plusieurs liaisons de pivot ou directement à la plaque de presse (10306), de préférence aux une ou plusieurs liaisons de pivot inférieures, dans lequel facultativement le moteur (10311) est placé de manière adjacente à l'actionneur linéaire et vers la face avant du logement.
10. Dispositif de compactage et de collecte d'ordures selon l'une quelconque des revendications précédentes, comprenant en outre un couvercle (1025) prévu dans l'ouverture d'insertion d'ordures et un système de verrouillage passif (104) qui empêche l'ouverture du couvercle lorsque l'unité de compactage n'est pas dans la position rétractée, dans lequel facultativement ledit système de verrouillage passif empêche également le mouvement de l'unité de compactage lorsque le couvercle est ouvert.
11. Dispositif de compactage et de collecte d'ordures selon l'une quelconque des revendications précédentes, dans lequel la plaque de presse (10306) atteint une orientation inclinée dans la position rétractée avec un angle ascendant par rapport à l'horizontale compris entre 10 et 80 degrés, de préférence entre 30 et 60 degrés.
12. Dispositif de compactage et de collecte d'ordures selon l'une quelconque des revendications précédentes, dans lequel la plaque de presse (10306) atteint une orientation sensiblement de niveau dans la position de pression avec une inclinaison vers le haut ou vers le bas par rapport à l'horizontale comprise entre 0 et 30 degrés.
13. En combinaison, un dispositif de compactage et de collecte d'ordures (101) selon l'une quelconque des revendications précédentes et un compartiment échangeable (105), par exemple agencé à l'intérieur du logement.
- 55

14. Procédé pour compacter et collecter des ordures, dans lequel on utilise un dispositif de compactage et de collecte d'ordures selon l'une quelconque des revendications précédentes, et dans lequel un compartiment échangeable (105) est agencé à l'intérieur du logement. 5

10

15

20

25

30

35

40

45

50

55

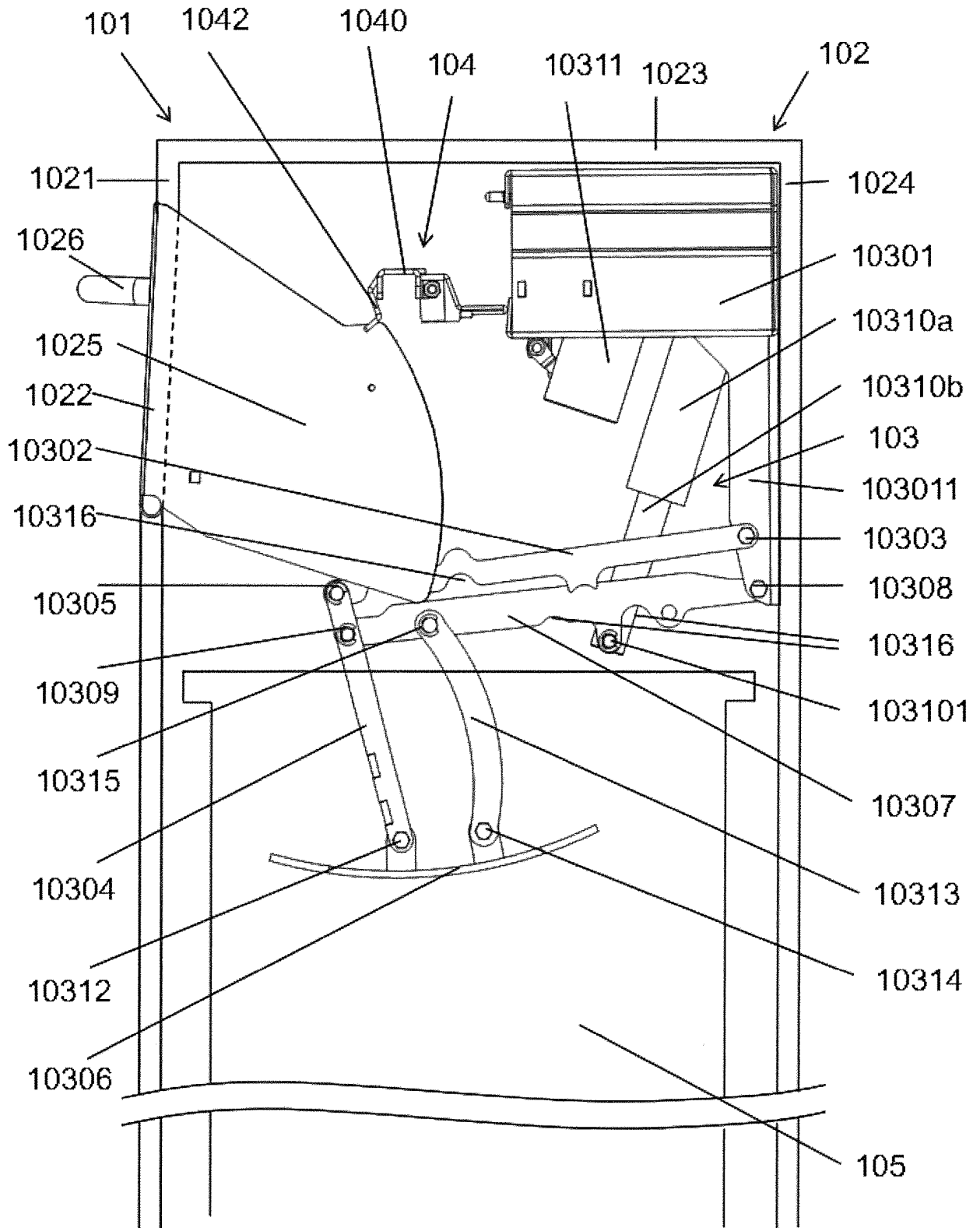

Fig. 1

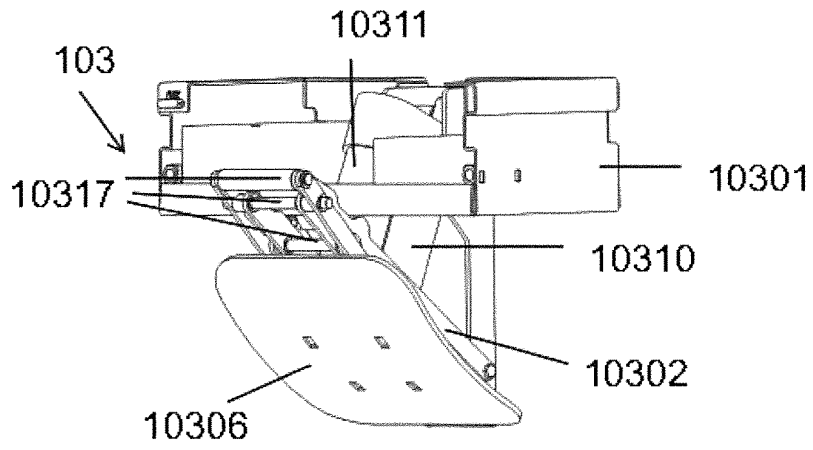

Fig. 2

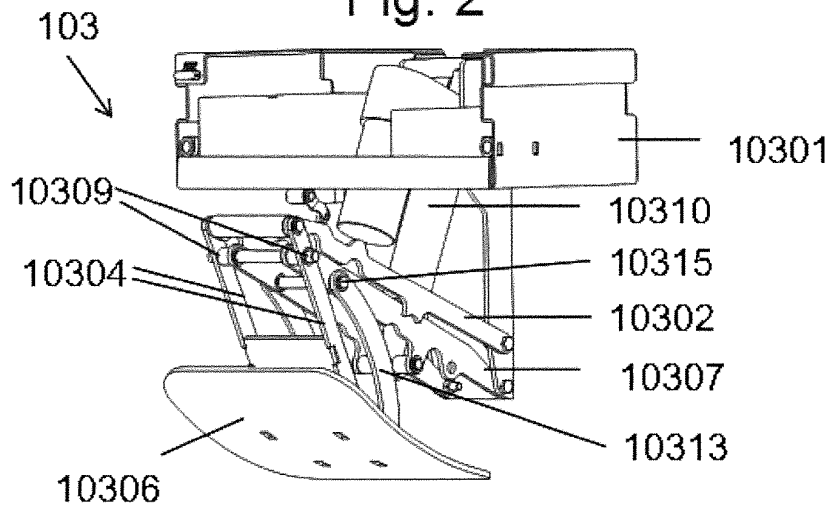

Fig. 3

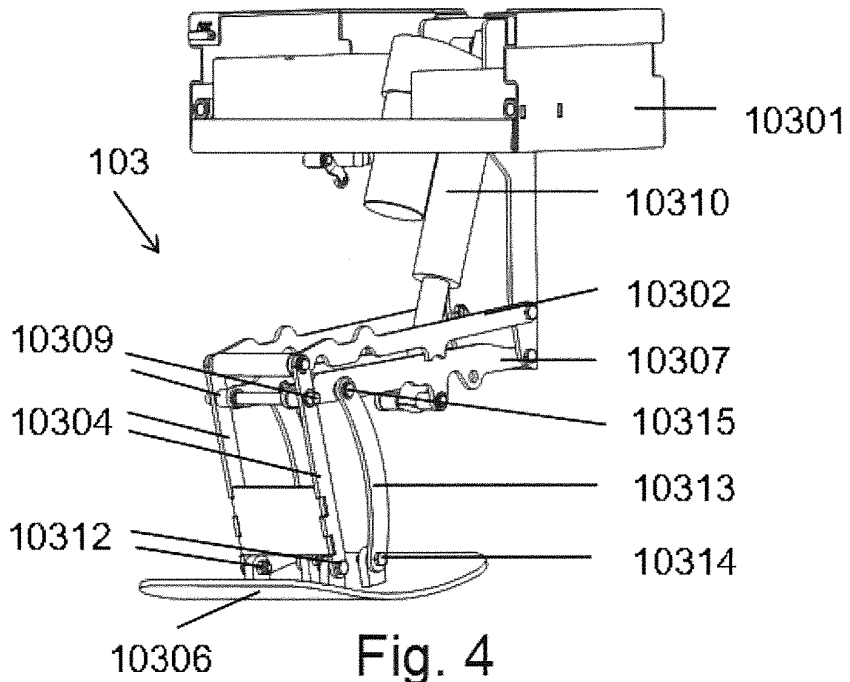

Fig. 4

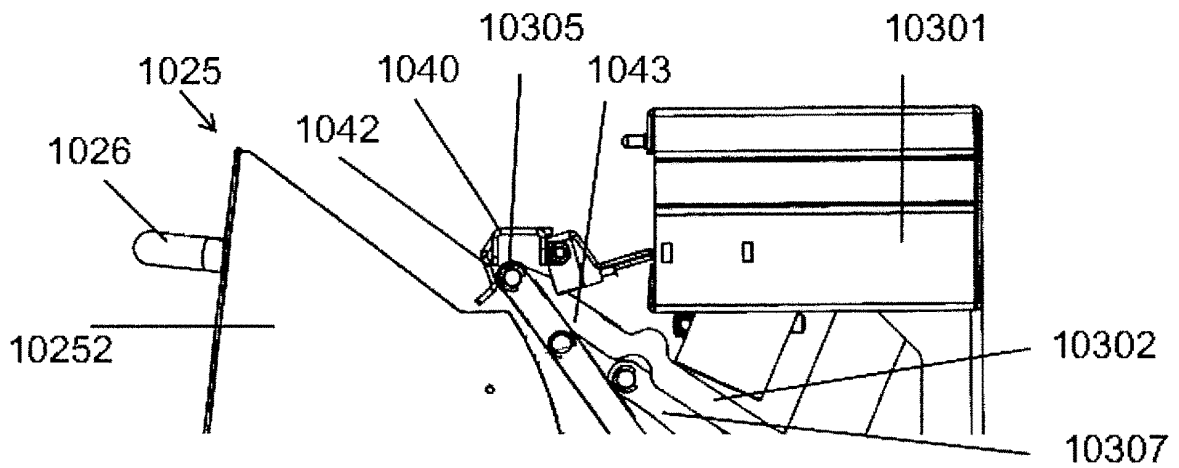

Fig. 5

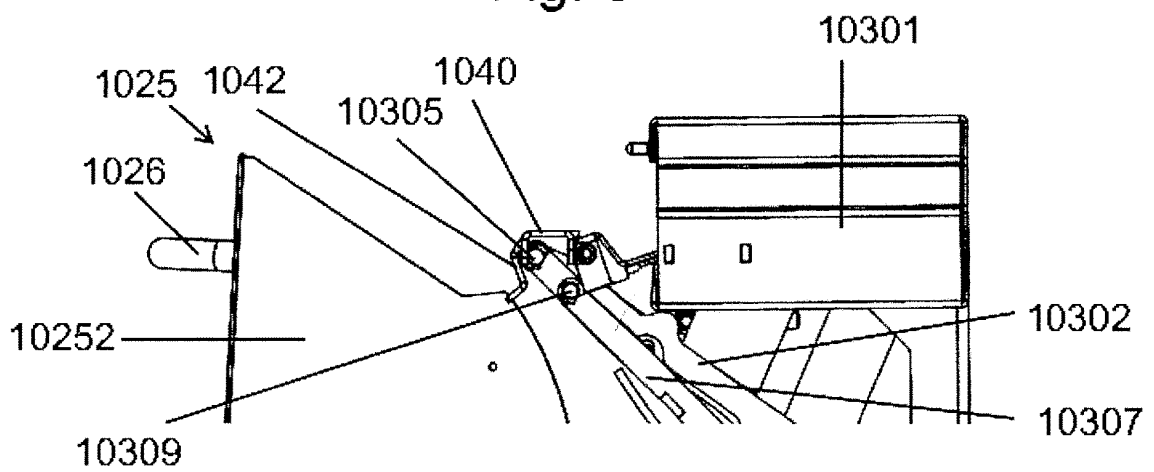

Fig. 6

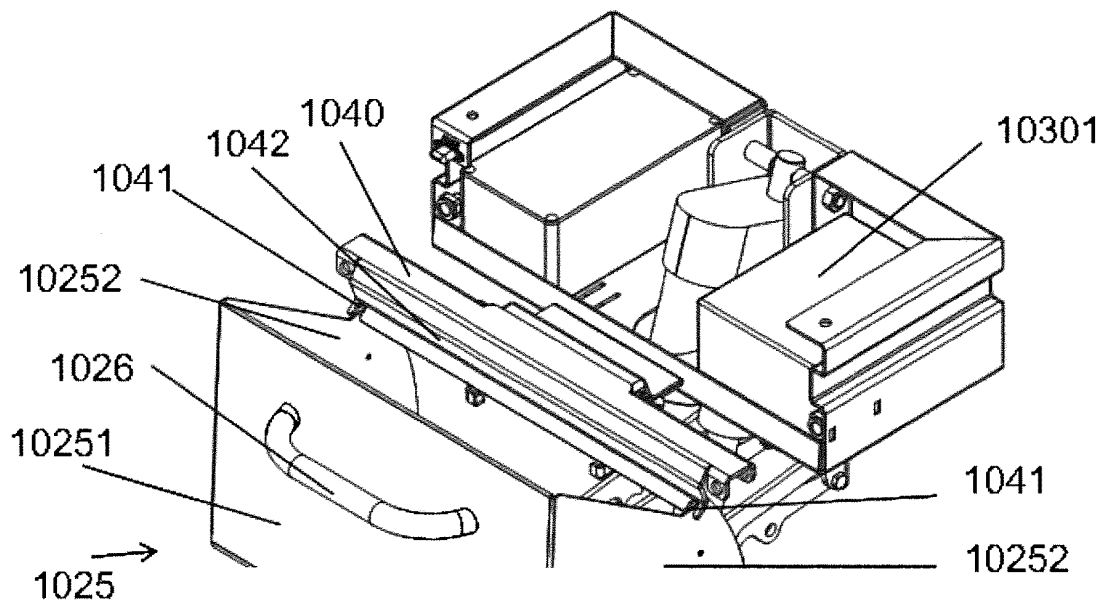

Fig. 7

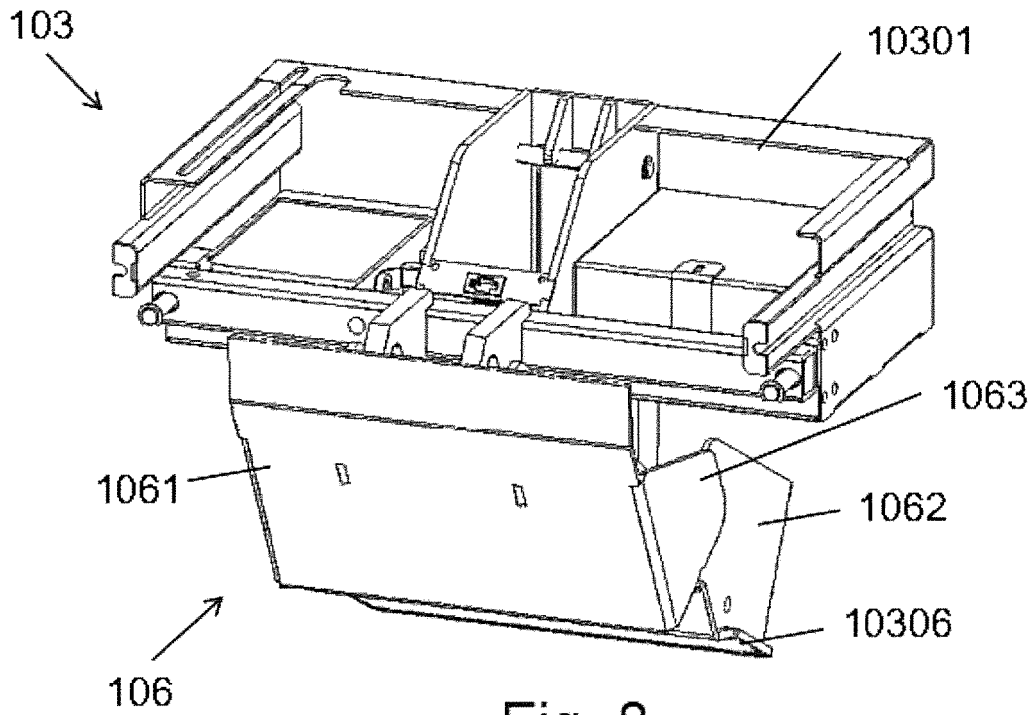

Fig. 8

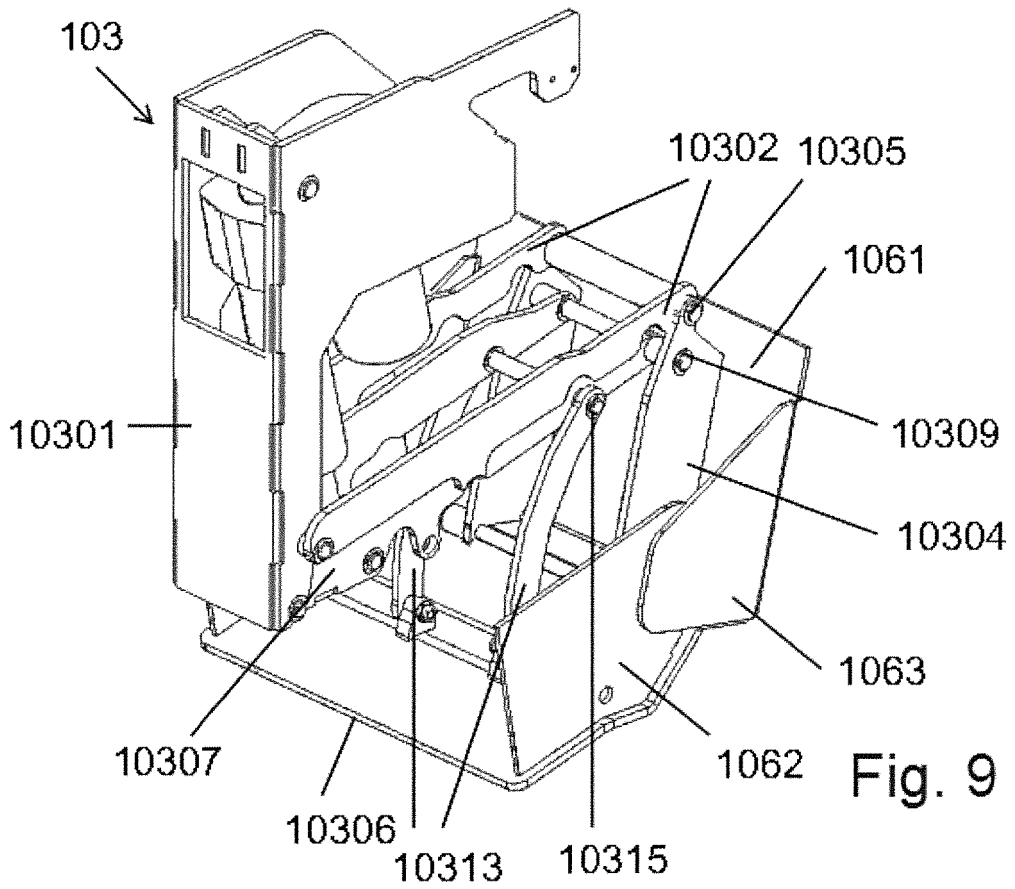

Fig. 9

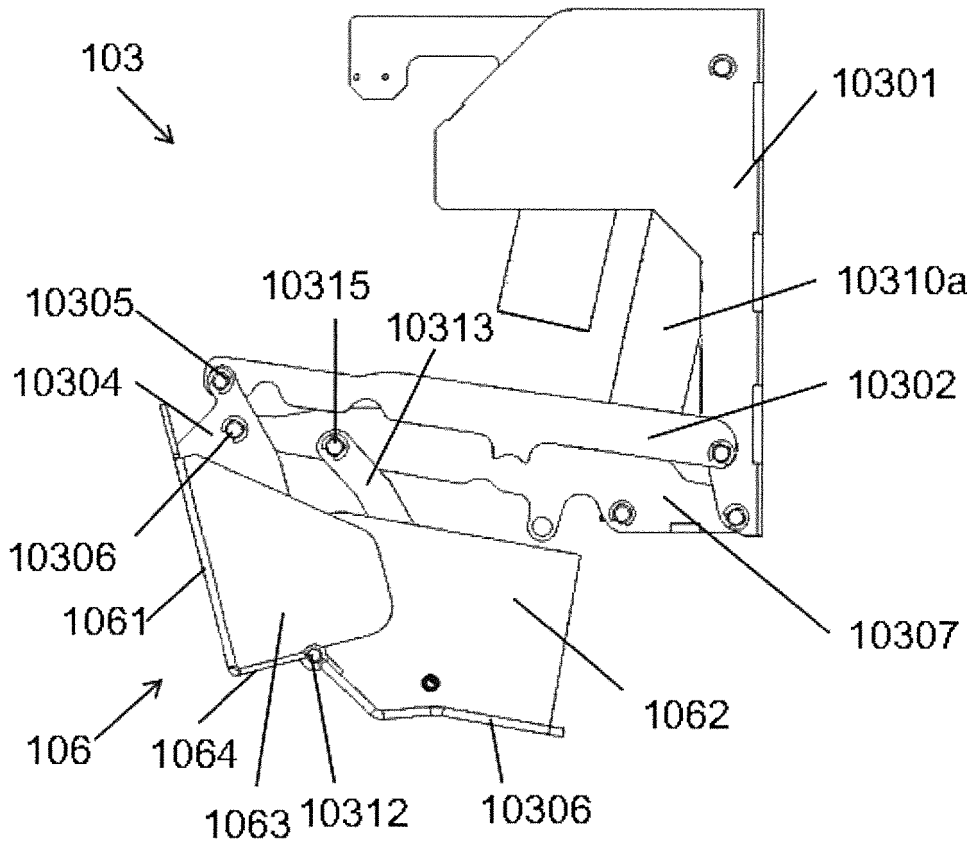

Fig. 10

REFERENCES CITED IN THE DESCRIPTION

This list of references cited by the applicant is for the reader's convenience only. It does not form part of the European patent document. Even though great care has been taken in compiling the references, errors or omissions cannot be excluded and the EPO disclaims all liability in this regard.

Patent documents cited in the description

- WO 2006073224 A [0003] [0004]
- CN 201228156 Y [0005]