

No. 641,885.

Patented Jan. 23, 1900.

J. PEARCE & G. H. JACKSON.
FINISHING TOOL FOR FACING PISTON RINGS.

(Application filed Sept. 2, 1899.)

(No Model.)

Fig. 1.

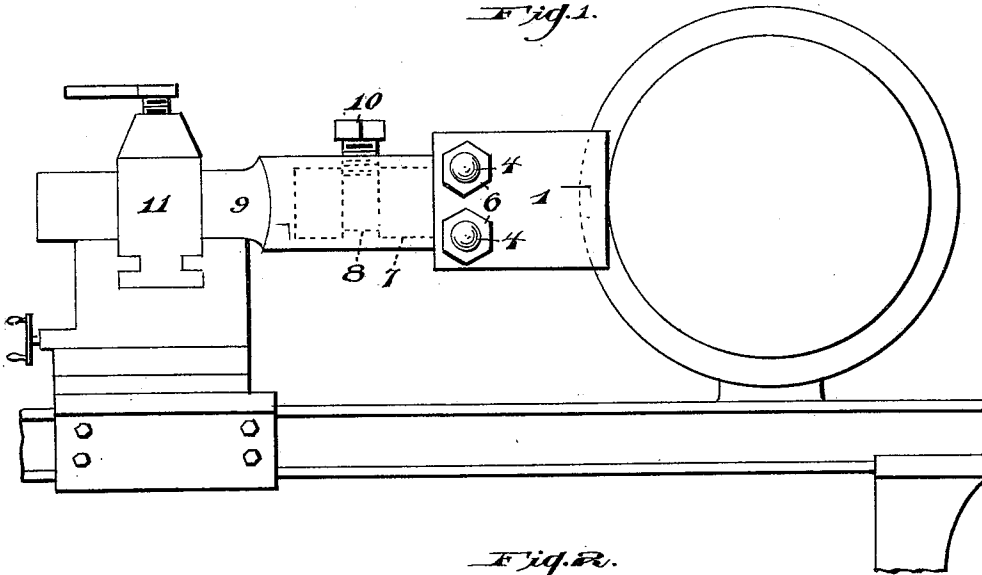

Fig. 2.

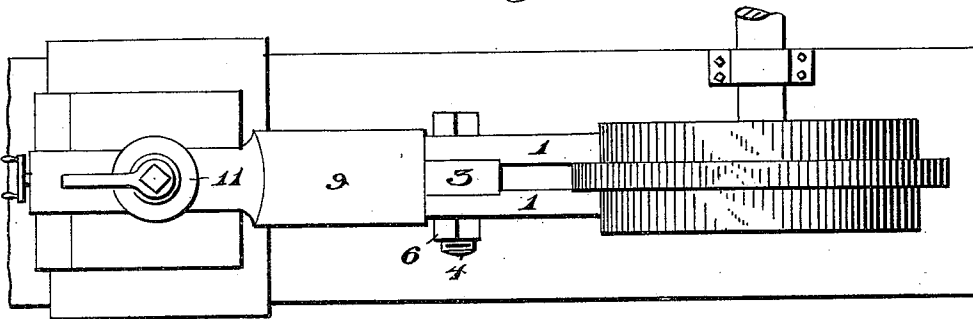

Fig. 3.

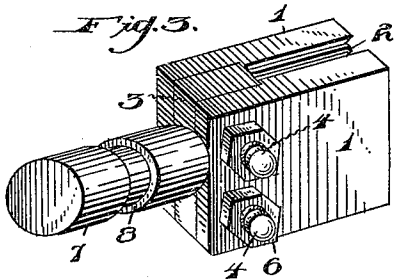
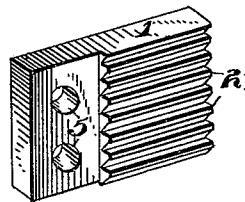

Fig. 4.



WITNESSES:

J. P. Appleman
W. M. Haymakers

INVENTORS-

Josiah Pearce
George H. Jackson

BY

A. C. Everitt & Co.
ATTORNEYS.

UNITED STATES PATENT OFFICE.

JOSIAH PEARCE AND GEORGE H. JACKSON, OF SWISSVALE, PENNSYLVANIA.

FINISHING-TOOL FOR FACING PISTON-RINGS.

SPECIFICATION forming part of Letters Patent No. 641,885, dated January 23, 1900.

Application filed September 2, 1899. Serial No. 729,327. (No model.)

To all whom it may concern:

Be it known that we, JOSIAH PEARCE and GEORGE H. JACKSON, citizens of the United States of America, residing at Swissvale, in the county of Allegheny and State of Pennsylvania, have invented certain new and useful Improvements in Finishing-Tools for Facing Piston-Rings, of which the following is a specification, reference being had therein to the accompanying drawings.

This invention relates to certain new and useful improvements in finishing-tools for facing piston-rings, and has for an object to construct a tool for this purpose that will be extremely simple in its construction, strong, durable, effectual in its operation, and comparatively inexpensive to manufacture.

The invention has for its further object to construct a tool of this character wherewith a perfectly even and smooth surface may be produced upon the sides of the piston-ring, which is not obtainable under the present methods without considerable labor and difficulty.

A still further object of the invention is to construct a tool for this purpose that will require no especial construction of tool-holder, but which may be easily and quickly secured in or removed from any ordinary tool-holder, as desired.

Briefly described, the invention consists of two similar plates which are provided on their inner faces with cutting-teeth extending in alinement with the plates. These two plates are suitably spaced apart, which may be done by a center block, as herein shown, to which the plates are rigidly secured. A shank is connected to this center block at the rear of the cutting-plates for holding the tool in the tool-holder, the shank being so constructed as to prevent the tool from becoming disengaged and also allow its rotation in the tool-holder.

In describing the invention in detail reference is had to the accompanying drawings, forming a part of this specification, and wherein like numerals of reference will be employed to designate similar parts throughout the several views, in which—

Figure 1 is a side view of our improved tool, showing the same in position in a tool-holder

and in engagement with the piston-ring. Fig. 2 is a top plan view of the same. Fig. 3 is a perspective view of our improved facing-tool, and Fig. 4 is a like view of one of the cutting-plates detached.

In facing the sides of piston-rings it is desirable, and, in fact, absolutely necessary, that these sides be perfectly smooth and true throughout in order that they will perfectly fit in the groove of the piston-head and prevent any escape of steam, gas, or the like between the ring and the wall of the groove, or, in other words, a perfect joint established, which has not heretofore been obtainable without the aid of grinding. This result is obtained by our improved tool, which consists of two substantially similar plates 1, which we herein term the "cutting-plates." These plates are shown in the accompanying drawings as being substantially rectangular in form, though we are of course not limited to this shape of cutting-plate to accomplish the result. We provide each of these plates with a series of cutting-teeth 2, which extend horizontally in alinement with the plates, and as the entire inner faces of the plates could not be brought into engagement with the piston-rings these teeth may be extended for but a portion of the length of the plates, as is illustrated herewith. The cutting-plates may be shouldered on their inner faces, extending from the rear end of the cutting-teeth to the rear ends of the plates, so that the portions of the plates which have the cutting-teeth thereon are of greater thickness, when measured from the outer edge of the cutting-teeth to the outer face of the plates, than the portions of the plates which are between the rear end of the cutting-teeth and the rear ends of the plates. These cutting-plates are spaced apart, so as to receive the piston-ring between the same and allow the cutting-teeth to engage and face the ring, by means of a center block 3, which we have shown as fitting neatly in the shouldered portions of the cutting-plates. This center block is secured in position and the cutting-plates secured thereto by means of bolts 4 4 passing through apertures 5 5 in the cutting-plates and through registering apertures provided therefor in the center block. These bolts are

held secure by nuts 6 6, as shown. This form of fastening is shown as the more convenient and practical one, though, of course, the cutting-plates could be riveted securely to the center or spacing block, if desired. The center or spacing block has formed integral with its rear face or secured thereto in any desirable manner a suitable stock or shank 7, which is provided at any suitable or desirable point with a peripheral groove 8. This stock or shank is adapted to engage in and be secured in the tool-holder 9, a convenient and practical means for securing the same being shown herein, which consists of a set-screw 10, arranged in the tool-holder 9 and adapted to engage in the peripheral groove 8 of the stock or shank. When the stock or shank is made cylindrical, it will be observed that this form of fastening will permit the rotation of the stock or shank within the tool-holder in order that the tool may be at all times in true alignment with and in proper position for perfectly facing the ring.

In Figs. 1 and 2 we have shown the tool-holder secured in the tool-post 11, the latter being supported on the lathe-bed in the ordinary manner. The piston-ring is also shown mounted upon a suitable mandrel, to which it is secured in any desirable manner and the mandrel driven to bring the sides of the ring into engagement with the cutting-teeth of the tool.

It is thought that with reference to the accompanying drawings the foregoing description will fully enable those skilled in the art to thoroughly understand the operation of the device without further detailed description thereof. We desire, however, to call attention to the fact that with the tool having the two plates—one to engage each side of the piston-ring and face the same—the ring must necessarily be faced absolutely true throughout by reason of the ring being simultaneously faced on both sides, and to accomplish this various changes might be made in the details of construction, such as the extending or decreasing the length of the cutting-teeth on the plates, the manner of spacing these plates apart, the manner of securing the same together in the construction of the stock or shank, and like details, without departing from the general spirit of our invention.

Having fully described our invention, what we claim as new, and desire to secure by Letters Patent, is—

1. A finishing-tool for facing piston-rings, comprising in its construction a pair of substantially rectangular plates which are suitably spaced apart and secured together, said plates being provided on their inner faces with cutting-teeth, and means for securing said plates in a tool-holder.

2. A finishing-tool for facing piston-rings, comprising in its construction a pair of plates provided on their inner faces with cutting-teeth extending in longitudinal alinement therewith, said plates being suitably spaced

apart and secured together, and means for securing said plates in a tool-holder.

3. A finishing-tool for facing piston-rings, comprising in its construction, a pair of plates provided on a portion of their inner faces with cutting-teeth extending in horizontal and longitudinal alinement, and means connected to the said plates for securing the same in a tool-holder.

4. A finishing-tool for facing piston-rings comprising in its construction, a pair of substantially rectangular plates which are provided on their inner faces with cutting-teeth, and means connected to said plates for securing the same in a tool-holder.

5. A finishing-tool for facing piston-rings, comprising in its construction, a pair of similar-shaped plates provided on their inner faces with cutting-teeth extending in horizontal and longitudinal alinement therewith, a spacing-block secured between said plates, and a stock or shank connected to said spacing-block.

6. A finishing-tool for facing piston-rings, comprising in its construction, a pair of similar-shaped plates which are provided on a portion of their inner faces with cutting-teeth extending in horizontal and longitudinal alinement therewith, means arranged between the plates for spacing the same apart and to which they are secured, and a stock or shank for securing the same in a tool-holder.

7. A finishing-tool comprising in its construction, a pair of substantially rectangular plates which are provided on their inner faces with cutting-teeth extending in horizontal alinement therewith, means arranged between the plates for spacing the same apart and to which they are secured, and means for securing said plates in a tool-holder.

8. A finishing-tool for facing piston-rings, comprising in its construction, a pair of plates suitably supported and spaced apart and provided with a series of horizontally and longitudinally extending cutting-teeth, substantially as described.

9. A finishing-tool for facing piston-rings, consisting of a pair of plates provided with a series of horizontally and longitudinally extending teeth, means for spacing the plates apart, and means for securing said plates in a tool-holder, substantially as described.

10. A finishing-tool for facing piston-rings, consisting of a pair of plates provided with a series of horizontally and longitudinally extending cutting-teeth, a center block arranged between the said plates, means for securing the said plates and block together, and means connected to the said block for securing the tool in a tool-holder, substantially as described.

11. A tool for facing piston-rings, consisting of a pair of substantially rectangular plates provided with a series of horizontally extending cutting-teeth, a center block arranged between the said plates, means for securing the said plates and block together,

and means connected to the said block for securing the tool in a tool-holder, substantially as described.

5 12. A finishing-tool for facing piston-rings, comprising in its construction a pair of plates provided on one face thereof with a series of horizontally and longitudinally extending cutting-teeth and having a shouldered portion, a center block secured to the said plates
10 at the shouldered portion, and a shank connected to the said center block for rotatably securing the tool in a tool-holder, substantially as described.

15 13. A tool for the purpose described, comprising in its construction, a pair of substan-

tially rectangular plates suitably spaced apart and secured together, said plates being provided on a portion of their inner faces with cutting-teeth which extend horizontally in alinement therewith, and means for rotatably securing said tool in a tool-holder, substantially as described.

In testimony whereof we affix our signatures in the presence of two witnesses.

JOSIAH PEARCE.
GEORGE H. JACKSON.

Witnesses:

JOHN NOLAND,
JOHN GROETZINGER.