

C. LEARNED.  
Hemp Brake.

No. 2,831.

Patented Oct. 22, 1842.

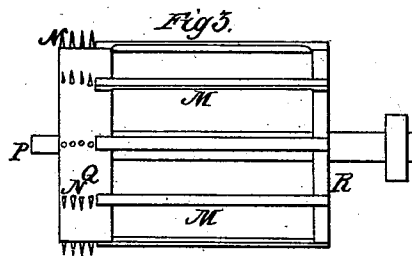
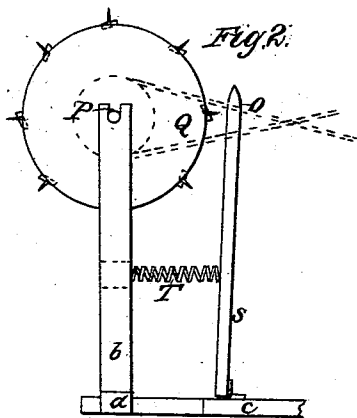
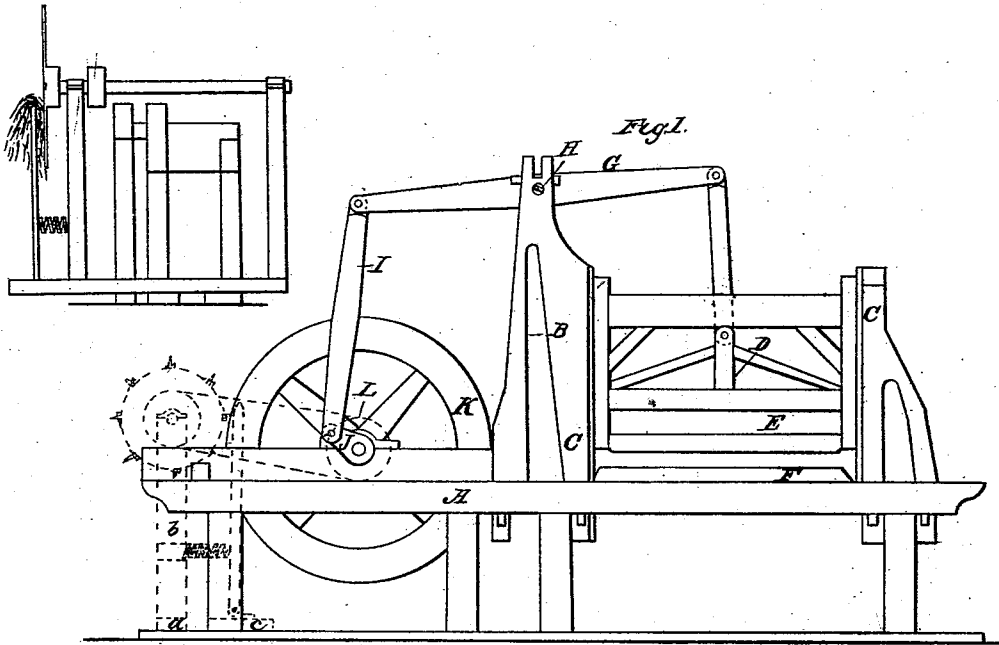

# UNITED STATES PATENT OFFICE.

CHARLES LEARNED, OF ST. LOUIS, MISSOURI.

IMPROVEMENT IN MACHINES FOR CLEANING AND HACKLING FLAX AND HEMP.

Specification forming part of Letters Patent No. 2,831, dated October 22, 1842.

*To all whom it may concern:*

Be it known that I, CHARLES LEARNED, of St. Louis, in the county of St. Louis and State of Missouri, have invented a new and useful Improvement in Machines for Breaking, Cleaning, and Hackling Hemp and Flax, &c., which is described as follows, reference being had to the annexed drawings of the same, making part of this specification.

Figure 1 is a side elevation of the machine; Fig. 2, a side elevation of the revolving drum and knives, jointed board, &c., for cleaning and hackling the hemp, &c.; Fig. 3, a front view of the revolving drums, knives, &c.

Similar letters refer to corresponding parts.

The frame A, Fig. 1, of this machine is made of sufficient size and strength to contain and support the parts hereinafter described. In the center of this frame and on the top thereof are framed two parallel uprights, B. Between these uprights, on one end of the frame, are framed four vertical parallel fender-posts, C. These posts are rabbeted on the inner corners to form grooves for a rectangular frame, D, to move up and down in. This frame is composed of four vertical timbers framed together. In this frame and at the bottom thereof are arranged a series of horizontal longitudinal parallel slats or bars, E, for breaking the hemp. A series or set of plates or bars, F, corresponding with those just described, are arranged below them in the frame, with spaces between them a little wider than the thickness of the rising and falling slats before described, in a horizontal and fixed position in the frame A, and longitudinal and parallel, so that the rising and falling slats can pass between them for breaking the hemp, &c., across them at right angles when thus placed by the operator. The rising and falling frame is attached to the extremity of a vibrating beam, G, turning on a horizontal bolt, H, as its fulcrum passes through the aforesaid posts and the said vibrating beam. The other end of the vibrating beam is connected by a pitman, I, to the wrist of a horizontal crank-shaft, J, turning in suitable boxes on the frame by any convenient power—horse, steam, manual, or other power—having on said shaft a fly-wheel, K, for steadying the motion, and a pulley, L, or suitable gearing for turning it. The frame A may be extended horizontally, so as to admit another rising and falling frame

of slats, and a series of stationary parallel slats between which they work, said frame being attached to the end of a walking-beam connected to the crank-shaft in the manner before described, so that they shall work simultaneously or alternately, as preferred. The flax or hemp to be broken is placed upon the horizontal fixed slats at right angles thereto. The movable slats are then brought down upon the hemp in that position, which breaks it and carries the hemp and broken stalk into the spaces between the slats. The movable slats are then raised and the hemp drawn forward toward the operator and the operation repeated, and so on until the bunch of hemp is completely broken. The slats may be placed nearer together at the ends next the center of the machine than at the opposite ends, for the purpose of gradually increasing the degree of fineness of the breaking as the operator brings the bundle of hemp from the widest ends of the spaces toward the ends placed nearer together. The slats, however, may be placed parallel, as before stated. The breaking of the hemp being completed, it is removed to the end of the frame A, where the broken stalk or shive and tow are separated from the hemp by revolving knives M and pins N, turned by a crossed band, O, passed around the pulley on the axle of drums to which the knives are fastened. These knives are arranged and operated in the following manner: A transverse horizontal sill-timber, a, is secured to the sills of the frame A at one end. Two upright posts, b, are secured at each end of this transverse timber by mortises and tenons. On top of each of these posts is fastened a box, in which turns a horizontal shaft, P, near each end of which are fastened two drums, Q R, or heads, about three feet in diameter and three feet apart—the one, Q, next the end of the shaft being about twice the width or thickness of the other. Eight or more wooden knives, M, are arranged and secured on the peripheries of these heads or drums at equal distances apart and extending from one drum to the other. These knives are of an oblong form, and are fastened and held securely in their places by being let into countersinks made in the peripheries of these heads, and secured by screws. From the periphery of the drum nearest the extremity of the horizontal shaft project as many rows of teeth, N

as there are knives, which teeth are for hackling the hemp or separating the tow from the same. A jointed rest or hackling board is placed in front of each set of knives, and near them upon or over the upper end of which the hemp or flax is placed to be operated on by the knives and teeth. This rest is jointed to a transverse sill, *c*, arranged and secured in a parallel line with the sill *a*, and is held off a short distance from the knives by a spiral spring, *T*, attached to it, and to a horizontal timber mortised and tenoned into the uprights and extending from one to the other. The operator takes the broken hemp and places it over the top of the jointed rest and holds it with his hand in that position, and pushes the rest with the hemp toward the knives until the hemp is in contact with them, and the knives having a rotary motion takes off the

broken particles of stalk or shive when the operator moves it along the top of the rest to the hackling-pins which separate the tow from the same. When this side is fully cleaned, the other is turned toward the knives and treated in a similar manner.

What I claim as my invention, and which I desire to secure by Letters Patent, is—

The method of combining the machine for whipping or cleaning with the hackling, so that the flax or hemp can be passed from one to the other by simply sliding it on the spring rest-board, as described, by attaching the cleaning-knives and hackling-pins to the same drum, in the manner described.

CHAS. LEARNED.

Witnesses:

E. MAHER,

F. H. SOUTHWORTH.