

(No Model.)

G. FOX.
STEAM BOILER.

No. 324,101.

Patented Aug. 11, 1885.

Fig. 1

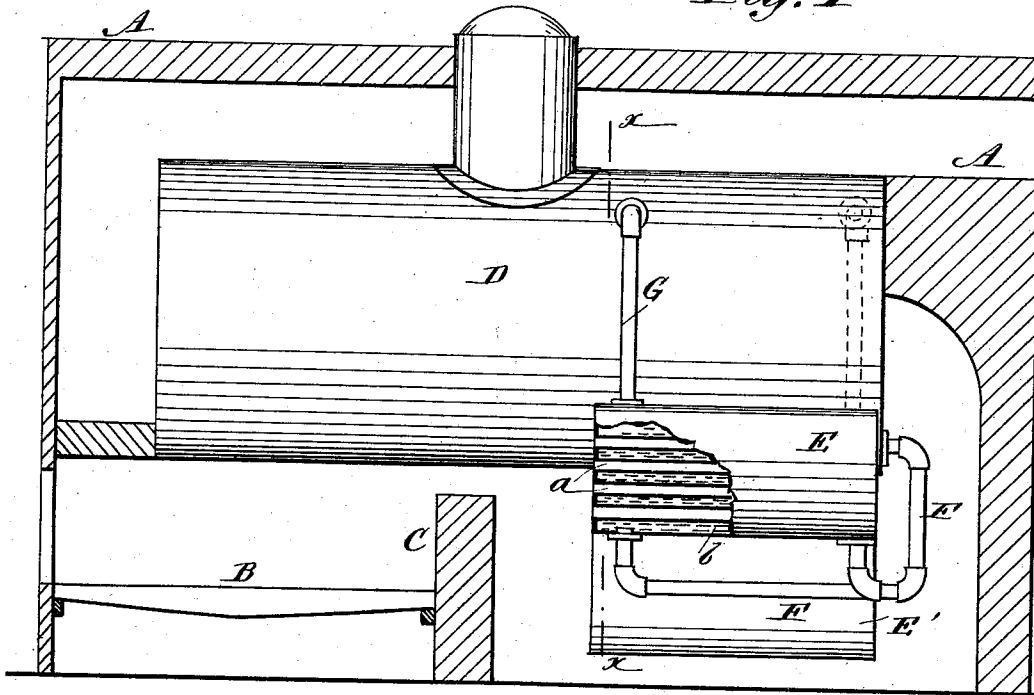
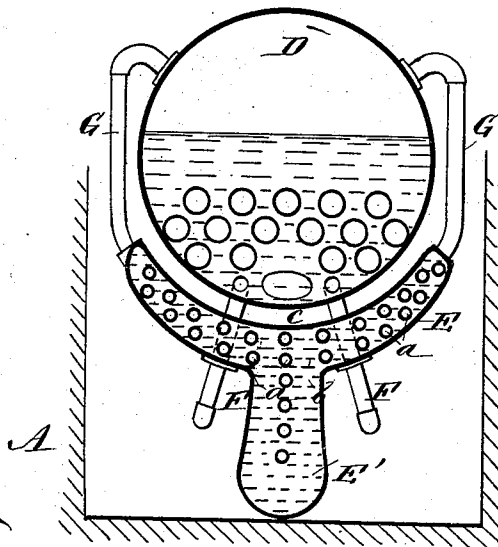

Fig. 2



WITNESSES:

C. Nelson
C. Sedgwick

INVENTOR:

G. Fox
BY *Munn & Co*
ATTORNEYS.

UNITED STATES PATENT OFFICE.

GEORGE FOX, OF NEW YORK, N. Y.

STEAM-BOILER.

SPECIFICATION forming part of Letters Patent No. 324,101, dated August 11, 1885.

Application filed April 16, 1885. (No model.)

To all whom it may concern:

Be it known that I, GEORGE FOX, of the city, county, and State of New York, have invented certain new and useful Improvements in Steam-Boilers, of which the following is a full, clear, and exact description.

My invention consists of a supplementary boiler connected with the main boiler by suitable pipes and placed in the fire-box for heating the water and generating steam therein, thus effecting economy in fuel.

Reference is to be had to the accompanying drawings, forming part of this specification, in which similar letters of reference indicate corresponding parts in the figures.

Figure 1 shows a furnace and boiler having my supplementary boiler applied thereto, the latter being broken away to show the preferred construction; and Fig. 2 is a transverse section on line *x x*, Fig. 1.

A represents the furnace, which is preferably of the reverberatory character, with grate-bars B and bridge-wall C. The main boiler D is fitted in the furnace A in an ordinary manner, and beneath it is placed the supplementary boiler E. This is by preference made concaved in form, with a downwardly-projecting pocket, E', and is by preference provided with fire-tubes *a a*, through which the flames and products of combustion from the fuel pass for heating the water in the water-space *b* of the boiler.

The pocket E' is to receive any sediment that may be deposited in the supplementary boiler. Water is supplied to the supplementary boiler E, preferably from the main boiler D, through the inlet-pipes F, which pass from the lower part of the boiler D down below the supplementary boiler and enter it at the bottom, as shown clearly in the drawings, so that the water will be considerably heated in the pipes F. The supplementary boiler is connected also with the main boiler by the return-pipes G, that conduct the water from the supplementary boiler back to the main boiler, and these pipes G by preference enter the main boiler above the water-line.

The supplementary boiler is so set beneath the main boiler D as to leave the space *c* be-

tween the upper and lower surfaces of the two boilers, through which heat and products of combustion may pass, so that the heat will be confined, and thus more effective upon both boilers. The lower part of the supplementary boiler is at the point of intensest heat in the furnace, so that the maximum amount of heat is utilized.

When the boilers are filled with water and the fire started, a continuous flow of water will take place from the main boiler to and from the supplementary boiler.

Having thus described my invention, what I claim as new, and desire to secure by Letters Patent, is—

1. The combination, with the main boiler, of a lower supplementary boiler, both boilers being arranged wholly within the furnace, and with the concaved surface of one boiler separated from the opposite surface of the other boiler by a flame or heat space or passage, substantially as shown and described, and for the purpose specified.

2. The supplementary boiler E, made concaved in shape, placed below the main boiler to leave space *c*, and connected with the main boiler, substantially as described.

3. The supplementary concaved boiler E, placed in the furnace below the main boiler and connected therewith by pipes F G, an intermediate space being provided between the two boilers, substantially as described.

4. The combination, with the main boiler D, of the supplementary boiler E, placed in the furnace to form space *c* between the two boilers, and connected with the main boiler by inlet-pipes F and return-pipes G, the former reaching below the supplementary concaved boiler, the latter entering the main boiler near its upper portion, substantially as described.

5. The supplementary boiler E, placed in the fire-box and connected with the main boiler, and formed with a downwardly-projecting pocket, substantially as and for the purposes set forth.

GEORGE FOX.

Witnesses:

H. A. WEST,
C. SEDGWICK.