

ROWE, MITCHELL & HAMILL,
BROADCAST SEEDSOWER

PATENTED

73548 *Fig. 1.* JAN 21 1868

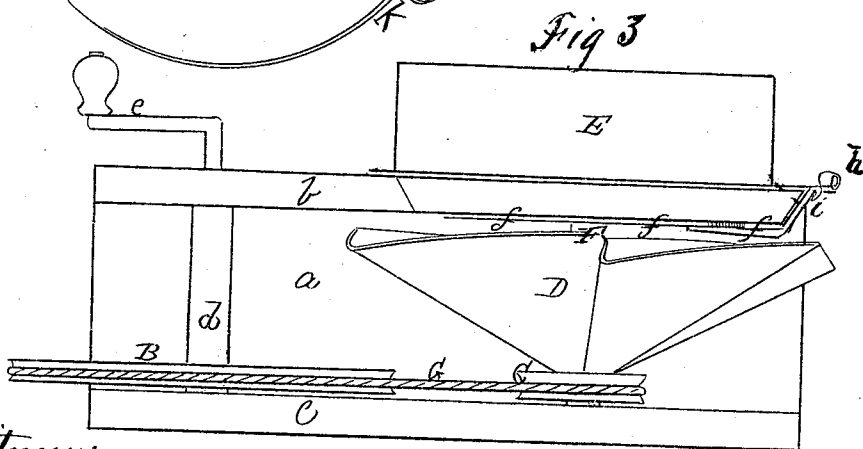
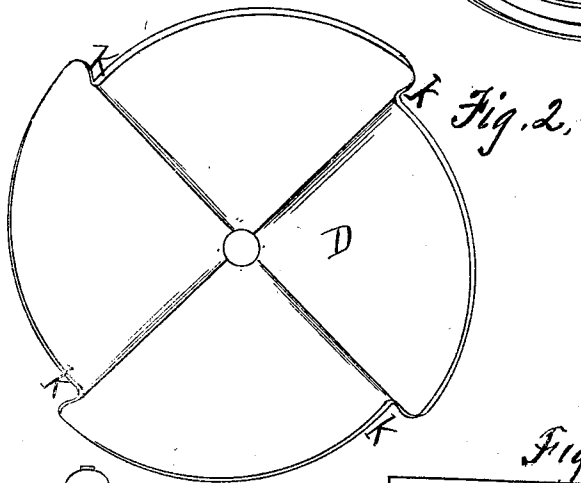
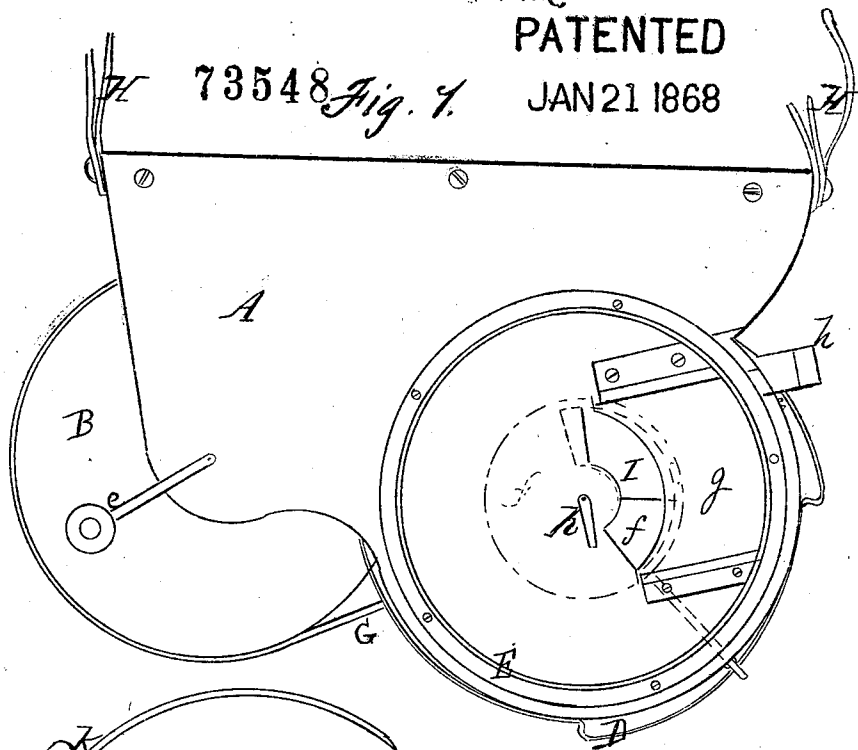

Witnesses

P. F. Dodge,
A. G. Cabell

Inventors

A. Rowe,
W. H. Mitchell,
G. P. Hamill,
by *D. S. & M. W.*
Mich. Atty.

United States Patent Office.

A. ROWE, W. H. MITCHELL, AND E. B. HAMILL, OF MACOMB, ILLINOIS.

Letters Patent No. 73,548, dated January 21, 1868.

IMPROVEMENT IN SEED-SOWER.

The Schedule referred to in these Letters Patent and making part of the same.

TO ALL WHOM IT MAY CONCERN:

Be it known that we, A. ROWE, W. H. MITCHELL, and E. B. HAMILL, of Macomb, in the county of McDonough, and State of Illinois, have invented certain new and useful Improvements in Broadcast Seed-Sowers; and we hereby declare that the following is a full, clear, and exact description thereof, reference being had to the accompanying drawings, making part of this specification, and to the letters of reference marked thereon, like letters indicating like parts wherever they occur.

To enable others skilled in the art to construct and use our invention, we will proceed to describe it.

Our invention relates to "broadcast seed-sowers," to be carried and worked by the operator, or attached to some moving vehicle, and consists of certain new and useful improvements in the manner of their construction, by which great evenness of sowing can be secured at all times. In the drawings—

Figure 1 is a top plan view.

Figure 2 is a view of a part detached; and

Figure 3 is a side or edge view.

In constructing our broadcast seed-sower, we make a frame, A, of suitable size and strength, consisting of a back piece, *a*, and top and bottom pieces *b c*, as shown in figs. 1 and 3. Between top and bottom pieces *b c* we place a driving-pulley, B, on a shaft, *d*, which has its bearings in the pieces *b* and *c*, and projects far enough above the former to be bent, and form the crank-handle *e*, or to have a crank-handle, *e*, attached. We also place between the pieces *b* and *c* a shaft, F, with its bearings in them, and on this shaft place a small pulley, C, in the same plane with the driving-pulley B. Immediately above the pulley C, on the shaft F, we attach the fluted concave D, made of a single piece of metal, as shown in figs. 2 and 3. This fluted concave D we make out of a circular piece of metal, by sinking it in the middle and forming up the rim, or by striking up the same with a die or hammer, so as to make the flutes or ribs *k*. On the upper side of the top piece *b*, and directly over the fluted concave D, we attach the hopper E, which is so formed that the mouth of a suitable-sized sack or bag may be attached to it. Near the centre of the space enclosed by the hopper E we make a circular oblong opening, I, in the top piece *b*, as seen in fig. 1, and provide it, on its upper side, with a sliding cover, *g*, for closing it transversely, and also provide it, on its under side, with an oscillating valve, *f*, to partially close it longitudinally, when desired. The sliding cover is moved by the handle, *h*, laterally, and the oscillating valve *f* by the handle *i*. The shaft F projects through the top piece within the hopper E, to be bent and form the arm *p*, or to have the arm *p* attached. This arm rotates with the shaft F.

In operating our sower, we first fill the hopper E, and the sack attached, with grain. The sack should be long enough to stretch up on to the shoulder of the operator, so that it may be held in an upright position. The sower we suspend from the shoulders of the operator, by means of the straps H. The operator then pulls out the sliding cover *g* at any desired distance, sets the rotating valve *f* as he wants it, and, as he steps forward across the field, turns the crank *e*, which moves the driving-pulley B, which, being connected with the small pulley *c*, drives it, and causes the fluted concave D to revolve rapidly.

The grain passes through the opening I into the centre of the fluted concave D, which, in revolving, gives it a centrifugal motion, and throws it off, along and out of the flutes *k*, in a uniform and even manner.

By means of the sliding cover *g*, we are able to suit the hole I to different-sized grain, as well as to regulate the flow. In windy weather, we find it advantageous to move the rotary valve *f* so as to cause the flow of the grain more directly in the centre of the fluted concave D, and then revolve it first in one direction and then in the other.

It is obvious that our sower may be attached to the rear end of a wagon or other vehicle, and operated as above described claims.

1. The fluted or ribbed concave disk D, made of a single plate struck up with the ribs *k*, in the form and manner substantially as shown and described.

2. The oblong curved opening I, for the passage of the grain from the hopper to the disk, as set forth.

3. In combination with the opening I, we claim the oscillating slide-valve *f*, for regulating the delivery of the grain at different points on the disk, as described.

4. The rotating arm *p*, mounted on the shaft F, and arranged to revolve within the hopper E, as shown and described.

Witnesses:

T. G. TUNNICLIFF,

T. CHANDLER.

A. ROWE,
W. H. MITCHELL,
E. B. HAMILL.