

*E. Davis,  
Cotton Press.*

*N<sup>o</sup> 10,960.*

*Patented May 23, 1854.*

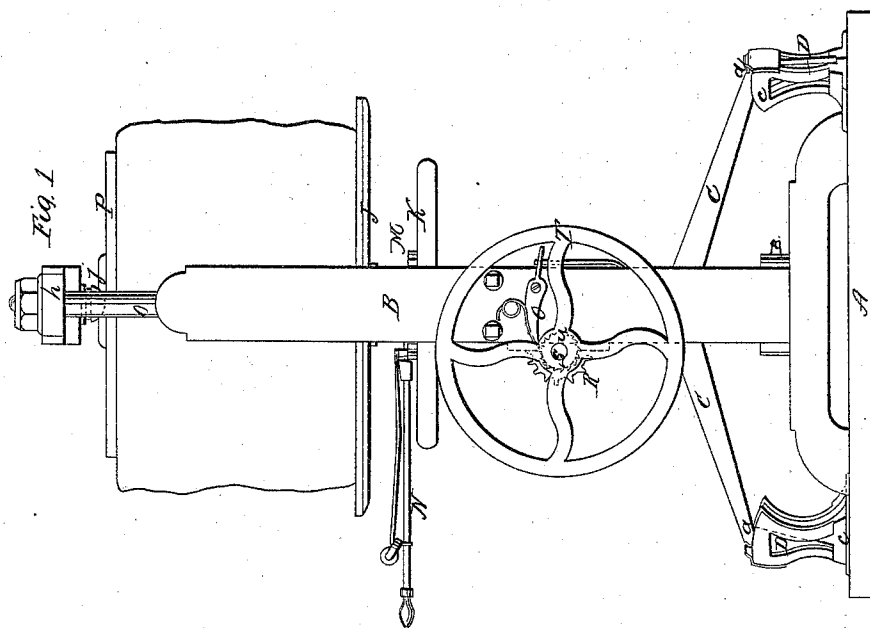
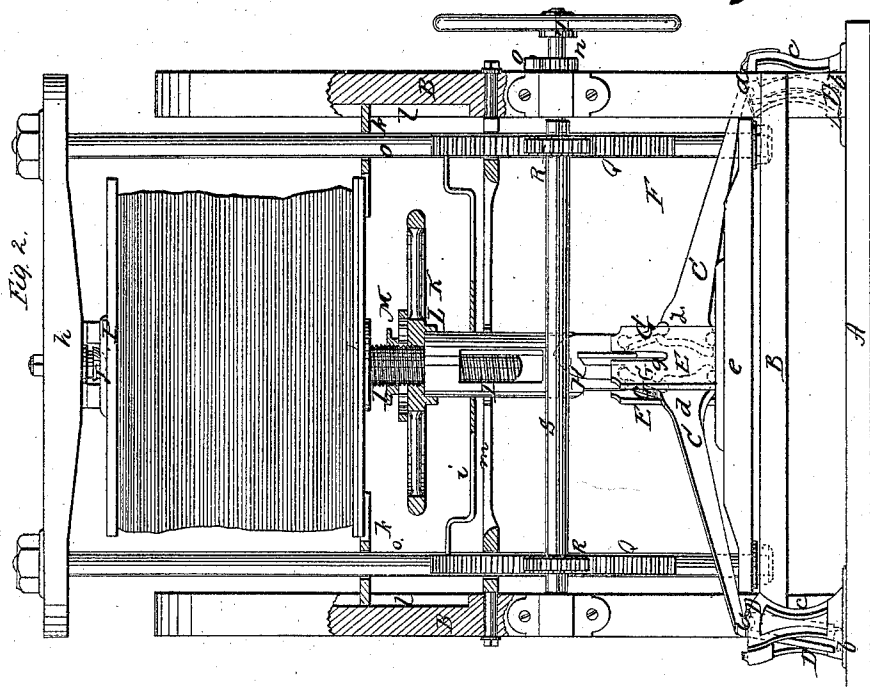

# UNITED STATES PATENT OFFICE.

ELIAS DAVIS, OF MONTPELIER, VERMONT.

## IMPROVED SELF-ACTING POWER-PRESS.

Specification forming part of Letters Patent No. 10,960, dated May 23, 1854.

*To all whom it may concern:*

Be it known that I, ELIAS DAVIS, of Montpelier, in Washington county and State of Vermont, have invented a new and useful Improvement in Self-Acting Accumulating Power-Presses; and I do hereby declare that the following is a full, clear, and exact description of the same, reference being had to the accompanying drawings, forming part of this specification, in which—

Figure 1 is an end elevation of the press. Fig. 2 is a front elevation of the same, parts of the framing, &c., being broken out and sectioned for the purpose of showing more plainly the construction and arrangement of the parts upon which the operation of the press mostly depends. The levers forming the toggle-joint, and also those which support the main levers, are shown plainly in dotted lines.

Similar letters of reference in each of the two figures indicate corresponding parts.

The nature of my invention consists in so arranging a series of horizontal and knuckle-joint levers below the screw and bed-plate, in combination with the peculiar manner of constructing and operating the press, that a progressive and powerful upward pressure in a straight line will be exerted upon the article being pressed by reason of its gravity and that of the movable portion of the press.

To enable others skilled in the art to make and use my invention, I will proceed to describe its construction and operation.

A represents the platform upon which the frame B is placed. This frame may be of wood and of the form and construction shown, or any more suitable.

C C are the two main knuckle-joint levers placed diagonally or transversely across the platform A, as shown in the drawings, the outer ends, *a a*, of said levers being so formed as to fit snugly and securely in a socket formed in the top of the levers D D, as shown in Fig. 2, and thus form a loose knuckle-joint, the lower ends of the levers D D having similar sockets cut in them, which fit over semicircular projections *b b*, on the bottom of the boxes or standards *c c*, in which the levers D D play up and down, and thus loose knuckle-joints are formed. The inner ends, *d d*, of the main levers C C fit and play freely up and down in the open box E, which is arranged in the cen-

ter of the lower sliding cross-piece, *e*, of the movable frame or press, F. Said ends *d d* have each two sockets formed in them—one at the top and the other at bottom. The bottom socket of each lever receives a projection on the bottom of the box E, and form knuckle-joints, while the top sockets receive the lower ends of two knuckle-joint levers, G G, as shown in Fig. 2, the upper ends of the levers G G being fitted snugly in sockets formed in the lower end of the vertical hollow piece H. Thus knuckle-joints at these points are also formed. The piece H has two flanges, *f*, which fit in the slots *g* in the sides of the box E, as shown in Fig. 2, and slide freely up and down in the same as the levers assume or move out of a horizontal position. By making this piece hollow for a certain portion of its length, it receives the screw I, carrying the bed-plate J, and allows of the bed-plate being lowered, as desired. The screw I plays perfectly free of the tube H.

K is a wheel, having a nut, L, cut in its center, by which the screw is operated and made to raise or lower the bed-plate J, as desired. This wheel has a ratchet, M, formed on its top, by which the screw I may be operated through the pawl-wrench N when it is not convenient to get at the wheel. The upper end of the tube H fits snugly in a socket on the under surface of the wheel K, as shown in Fig. 2. It is by thus connecting the tube H with the screw-wheel K that the power of the levers is transferred to the bed-plate J, as will be evident from the drawings.

The press F is composed of two vertical rods, O O, united together at top and bottom by the cross-pieces *e h*, and at center by the guide-piece *i*, through which the tube H moves freely up and down. The top cross-piece, *h*, carries the follower P, which is attached to it by ball-and-socket joint *j*.

The bed-plate J is attached to the screw, and is guided in its up-and-down movement by the pieces *k k*, attached to its bottom, and moving in grooves *l l* in the frame B, as shown. The pieces *k k* also serve as guides for the rods O O of the press. Q Q are racks formed on the rods O O, and R R are small pinions on the driving-shaft S. These racks and pinions serve to raise the press after it has performed the pressing operation. They also serve for

transmitting additional power to the levers from the wheel T, when the weight of the article and the gravity of the press is not sufficient to carry the main levers down to a horizontal position. The press F moves freely up and down through the slotted metal cross-tie *m* of the frame B.

*n* is a small ratchet-wheel provided with a pawl, *o*, for retaining the press elevated while preparing for operation, the pawl being kept out of connection by a spring, and in connection by a catch.

The operation of this press is as follows: After the substance has been placed on the bed-plate, block up the space between it and the follower P, raise the press F by the wheel T, and throw the pawl in connection with the ratchet, so as to hold the press elevated. Next, raise the bed-plate J by the horizontal screw-wheel K or pawl-wrench N. This operation will cause the tube H to descend and the inner ends of the horizontal levers C C to ascend, as will be seen from the drawings, and the outer ends to descend, and thereby operate upon the vertical levers D D and those G G, and draw them to an inclined position, as shown in the drawings, Fig. 2. Everything being arranged, the pawl *o* is raised and held by its spring, and the press is allowed to descend gradually by its gravity and that of the weight, the effect of which is the forcing of the main levers from their inclined position to that of a horizontal position, and the levers D D and G G to assume a vertical position, and consequently the tube H, which transmits power through the screw to the bed-plate, to be

elevated a considerable distance, and thereby cause a powerful resistance or upward pressure to be thrown upon the article being pressed. Should it occur, by the yielding of the article, that the press settles wholly down, then raise the press by the wheel T and turn the horizontal wheel K sufficiently to bring the levers into effective use; and when a substance is to be pressed requiring more power than the gravity of the press and itself can effect, then reverse the wheel T and bring the wheel, pinions, and sideracks to bear with the gravity of the press upon the levers; and, further, if still more power is required, a weighted lever can be adjusted to the wheel T in any suitable manner. To remove the substance from the press, raise slightly by the wheel T, turn the horizontal wheel back a few turns, and let the press down, this operation moving the bed-plate from the follower.

What I claim as my invention, and desire to secure by Letters Patent, is—

The peculiar arrangement of the horizontal levers C C, vertical levers D D and G G below the screw and bed-plate, in combination with the manner, herein described, of constructing and operating the press, whereby an accumulative upward pressure in a straight line can be exerted upon the article being pressed, by reason of its gravity and that of the moving portion of the press, substantially as set forth and specified.

ELIAS DAVIS.

Witnesses:

FERRAND F. MERRILL,  
WILLIAM L. HUNTER.