

L. A. ANDREWS.
PUMP.

APPLICATION FILED FEB. 5, 1920.

1,431,355.

Patented Oct. 10, 1922.

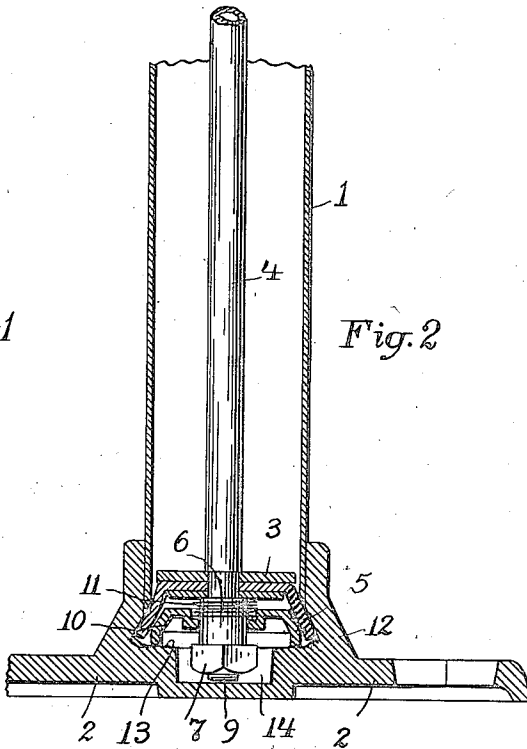
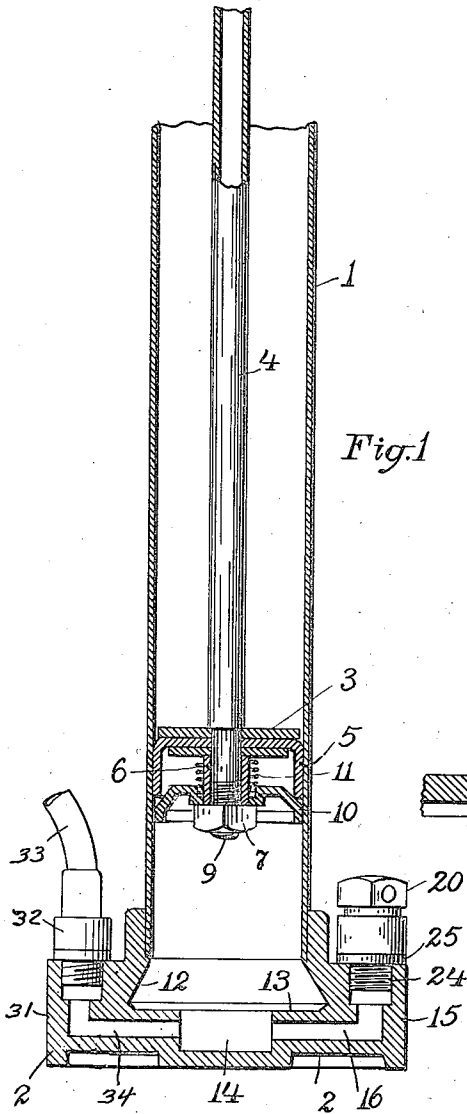
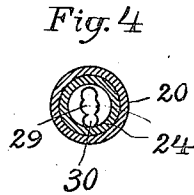
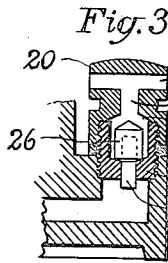
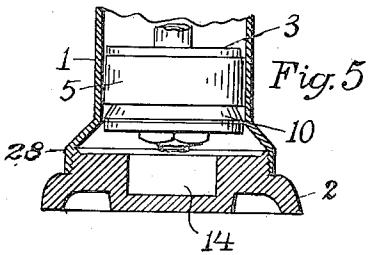

Inventor,
Louis A. Andrews;
By W. B. Upham,
Attorney.

UNITED STATES PATENT OFFICE.

LOUIS A. ANDREWS, OF NEWTON UPPER FALLS, MASSACHUSETTS.

PUMP.

Application filed February 5, 1920. Serial No. 356,800.

To all whom it may concern:

Be it known that I, LOUIS A. ANDREWS, a subject of the King of Italy, and a resident of Newton Upper Falls, in the county of Middlesex and Commonwealth of Massachusetts, have invented certain new and useful Improvements in Pumps; and I do hereby declare the following to be a full, clear, and exact description of the invention, such as will enable others skilled in the art to which it appertains to make and use the same.

This invention relates to pumps and involves the provision in a pump, more especially the hand operated type and suitable for pumping air, water, or in fact any fluid, of means for maintaining a tight fit between the piston and the inner wall of the cylinder.

In pumps of this character the piston is made to include a flexible cup-shaped or so-called "bucket" washer which usually consists of leather. This washer is provided for the purpose of producing, by reason of its shape and flexibility, a tight fit between the piston and the inner wall of the cylinder, or pump barrel, as well during the upward or suction stroke, when the fluid is drawn into the cylinder, as during the downward or compression stroke, when the fluid is compressed and forced out of the cylinder. It has been found in practice, however, that the flexible washer, especially after prolonged use, has a tendency to lose, to a certain extent, its original form by shrinking or flexing inwardly away from the inner wall of the cylinder. The new form or shape resulting from this inward flexure is assumed by the washer particularly during the upward or suction stroke with consequent leakage of air past the piston to partially break down the suction created thereby, and thus impair the operation of the pump. It is also evident that in the absence of means for correcting this deformation of the bucket washer there might also be leakage of air past the piston during the compression stroke, but this difficulty would be less pronounced due to the tendency of the air under compression to force the bucket washer against the cylinder wall.

The present invention, therefore, involves the provision of means for maintaining a

tight fit between the cylinder and the piston during both the suction and compression strokes.

In accordance with one form of the invention the cylinder or barrel of the pump has a diametrical enlargement at its lower end, and the piston includes in its construction a bucket washer. Loosely suspended below the piston, or carried thereby, and spaced below the bucket washer, is a circular piece or cone, constituting an expansion member, the base of which is nearly equal in diameter to the interior of the cylinder, and the upper diameter of which is preferably less than the interior of the bucket washer so that this member will fit into the washer. The loosely mounted member or cone is, in this construction, preferably held in spaced relation to the bucket washer by means of a spring interposed between them. When the piston reaches the bottom of the cylinder at the end of the compression stroke, the circular piece or cone is moved against the bucket washer thereby forcing or crowding the bucket washer outwardly, expanding it into the enlargement of the cylinder. Then, as the piston is raised upwardly from this position, the bucket washer engages the lower end of the cylinder and is reduced thereby to the size of the inner working diameter of the cylinder which produces a snug fit between the washer and the inner wall of the cylinder. In this way the bucket washer is reformed after each compression stroke so that it will tightly fit the pump cylinder and prevent leakage of air past the piston not only during the suction stroke, but as well during the compression stroke.

In the specific embodiment of this form of my invention hereinafter described, the piston rod has a shoulder spaced from its lower end, and the piston is mounted on the piston rod below this shoulder. In order to secure the piston in place there is provided a tube which is mounted on the piston rod below the piston, and a nut which is screwed on the lower end of the piston rod to press the tube against the piston and firmly hold the latter in position against the shoulder. The device for expanding the bucket washer into the enlargement of the cylinder at the end of each compression stroke consists of a conical expansion member which is loosely

mounted on the tube, and is held in spaced relation to the bucket washer by means of a helical spring which presses the expanding member down upon the nut, the conical

5 member having its largest and lowest diameter slightly less than the interior of the cylinder.

Where the shrinkage or inward flexing of the washer might be so pronounced as to result in leakage of air past the piston, especially during the compression stroke, despite the reforming of the washer by the expanding device, the invention further comprehends as a distinct part thereof a pump construction in which a movable expanding member or block is carried on the end of the piston rod, the piston including a cupped flexible washer. Between the block and washer are means for normally holding them

10 in spaced relation, and the block and washer are so constructed and arranged as to be brought into engagement on the down stroke of the piston to cause the block to bear against portions of the washer to hold them

15 in contact with the inner wall of the cylinder. Thus a tight joint will be produced between the piston and the cylinder by positive action of the expanding member against the bucket washer throughout the compression stroke. It will be understood

20 that in this form of my invention the cylinder or pump barrel might be of the usual construction, that is to say of uniform diameter throughout. It will be evident, however, that where the expanding device would be brought to bear against the washer throughout the down stroke of the piston without expansion of the washer at the end of the stroke beyond the size of the working diameter of the cylinder, the device

25 would be effective merely to maintain a tight joint during the compression stroke since means are provided for normally holding the expansion device and the bucket washer apart during the up stroke or suction stroke of the piston. In one application of my invention, therefore, it will be seen that both the forcing or crowding outwardly of the bucket washer against the

30 cylinder wall by the expansion member to maintain a tight fit during the compression stroke, and the expansion of the bucket washer into a diametrical enlargement at the base of the pump barrel at the end of the compression stroke to effect a tight fit during both the suction and compression stroke, may be combined in one structure by a suitable construction, arrangement and

35 proportioning of the parts. For example, in order that the expansion member may bear against the bucket washer during the compression stroke, becoming effective at the beginning of the stroke and continuing until the end of the stroke when the washer is expanded into the enlargement, the means for

holding the bucket washer and expansion member in spaced relation, such as a spring, may be made sufficiently light so that the pressure during compression will be sufficient to force the expansion device against the bucket washer and hold it in this position throughout the compression stroke. This result would be enhanced by also making the lower diameter of the expanding member more nearly equal to the inner diameter of the cylinder so as to make the pressure due to the air compression within the cylinder more effective in forcing the expanding member against the washer. It will be evident also that a spring tension could be selected such that during the compression stroke the expansion member would be permitted to move part way toward the washer to bear against portions thereof and press them against the cylinder wall, whereupon, at the end of the piston stroke, the expansion device would be moved upwardly by contact with the base of the pump the remainder of the distance separating it from the washer to expand the latter into the enlargement.

The invention is illustrated in the accompanying drawings in application, as an example, to a pump the cylinder of which has an enlargement at the base for the expansion therein of the bucket washer to a diameter exceeding the diameter of the cylinder of the pump. In these drawings—

Fig. 1 is a sectional elevation of the pump showing the piston construction;

Fig. 2 is a similar sectional view showing the piston in position at the end of the down stroke;

Fig. 3 is a sectional view of the intake valve;

Fig. 4 is a cross section of a portion of this valve, and

Fig. 5 is a sectional view illustrating a modified form of construction for the enlargement at the base of the pump.

The cylinder 1 has its lower end attached to a base 2 in a well known manner, and is provided with a piston 3 and a piston rod 4. The piston has a leather bucket washer 5 of well known form, held in place by a tube 6 and a nut 7 on the threaded stem 9 of the piston rod 4. The pressure of the nut against the end of the tube 6 fastens the piston and washer in place on the piston rod.

Loosely mounted on this tube 6 is an expansion member or block, 10 a portion of whose outer periphery is shaped like the frustrum of a cone and whose largest diameter is almost equal to that of the interior of the cylinder 1. A helical spring 11 mounted on the tube 6 serves normally to retain the cone 10 upon the nut 7.

In the base 2 below the end of the cylinder 1 is formed a conical enlargement 12, a flat floor 13 and a central well 14. At one side

70

75

80

85

90

95

100

105

110

115

120

125

130

of the base is a boss 15 tapped for having an inlet valve screwed therein, the opening in this boss being connected with the well 14 by a conduit 16. The inlet valve comprises a head 20 having a valve seat 21, a hole 22 rising from this seat, and one or more horizontal branch holes 23 communicating with the central hole 22. Up into the threaded lower end of the head 20 is screwed a threaded thimble 24 whose lower end is screwed into the boss 15, a washer 25 acting to render both screw-surfaces air-tight. The valve itself consists of a rubber tip 26 having a metal stem 27 which descends through a hole 29 in the thimble 24 for the better guidance of the valve. As shown in Fig. 4, one or more holes 30 are also formed through the floor of the thimble to permit air to freely pass through the same. Similarly the base of the pump is provided with means for permitting the outflow of air compressed in the cylinder. For this purpose the base 2 is formed with a boss 31 which is tapped to receive an outlet valve 32 provided with means for connecting thereto a flexible hose 33 to conduct the air to the point of delivery in the usual manner, and the opening in the boss is connected with the well 14 by a conduit 34. The valve 32 may have a construction similar to the intake valve, the details of which are shown in Fig. 3, except that the valve member 26 would be arranged to operate in the reverse manner to that when functioning as an intake valve, as will be readily understood; or the valve 32 may be of any conventional construction.

The operation of the pump is as follows: When the piston is depressed to its lowest point, the cone 10 comes in contact with the floor 13 and is forced up into engagement with the bucket washer 5, thereby forcing or crowding the latter outward into the enlargement 12, as shown in Fig. 2. Then when the piston is raised, the cone remains on the floor 12 until the washer is free thereof, but as the piston further rises, the expanded washer is contracted by its engagement with the cylinder-end and made to snugly fit the cylinder. This will be the operation of the pump where the spring 11 is made sufficiently strong to withstand the pressure of the air compressed in the cylinder below the piston during the down stroke to hold the cone 10 and bucket washer 5 in spaced relation, this result being made possible also by the fact that the cone 10 is made somewhat smaller in diameter than the inside diameter of the cylinder so that air may escape past it during the down stroke. It will be understood, however, that this operation may be modified by providing a lighter spring and a closer fit of the cone 10 within the cylinder so that during the down stroke the air pressure will force the cone 10 against the washer and hold the downwardly pro-

jecting end portions thereof in contact with the cylinder wall through the greater part or the entire downward stroke.

As shown in Fig. 5, the cylinder 1 may be itself pressed outward at its lower end to form a conical enlargement 12, and this conical enlargement made to terminate in an annular section 28 which is internally threaded and screwed upon a boss composing a part of the base 2. It is, of course, operated in the same manner as the construction first described, but on account of its superior lightness, I prefer this construction for very many purposes.

What I claim is:

1. A pump comprising a cylinder, and a piston movable therein, the cylinder having a diametrical enlargement at its lower end, the piston having a bucket washer, and a cone loosely carried by the piston spaced below the bucket washer, the base of the cone being nearly equal in diameter to the interior of the cylinder, whereby, when the piston reaches the bottom of the cylinder, the cone is made to expand the bucket washer into said enlargement.

2. A pump comprising a cylinder, and a piston movable therein, the cylinder having a diametrical enlargement at its lower end, and the piston having a bucket washer, and a circular member loosely suspended below the piston, the lower diameter of said member being nearly equal to that of the cylinder and its upper diameter being less than that of the interior of the bucket washer, a spring being provided for normally retaining said member spaced from the piston.

3. A pump comprising a cylinder having an enlargement at its lower end, a piston, a piston rod having a shoulder spaced from its lower end, the piston being mounted on the rod below said shoulder, a tube mounted on the piston rod below the piston, a nut on the lower end of the piston rod pressing the tube and piston firmly upward against said shoulder, a conical member loosely mounted on said tube, and a helical spring mounted on said tube and pressing the conical member down on said nut, said conical member having its largest and lowest diameter slightly less than that of the interior of the cylinder, the piston having a bucket washer.

4. In a device of the class described, the combination with a piston rod, of a pair of washers on said rod, a leather washer between the washers of said pair, a block carried by said rod and adapted to move toward the pair of washers and bear against portions of the leather washer for producing a tight joint, and a spring interposed between the block and the washers for normally holding the block from engagement or a crowding position with the leather washer.

5. In a device of the class described, the combination with a piston rod, of a primary and an auxiliary washer on said piston rod, the auxiliary washer being of less diameter than the primary washer, a cup-like leather washer between the primary and auxiliary washers, a slidable block carried by the rod under the washers and being adapted to engage the leather washer for crowding the same outwardly, and a spring between the block and the auxiliary washer for normally holding said block in an inoperative position with respect to the leather washer.

6. In a device of the class described, a piston rod carrying a piston and an expanding block, said piston including a cupped, flexible washer, and means interposed between the block and the washer for normally holding them in spaced relation, said block and washer being constructed and arranged to be brought into engage-

ment on the downstroke of the piston to cause the block to bear against portions of the washer thereby to maintain a tight joint. .25

7. A pump comprising a cylinder, a piston rod, and a piston mounted on said rod and movable within the cylinder, said piston including a cupped, flexible washer, and said rod having loosely mounted thereon an expanding device normally held in spaced relation to said washer, said expanding device being constructed and arranged to move against said washer at the end of the piston stroke to expand portions of the washer against the cylinder wall thereby to maintain a tight joint. 30 35

In testimony that I claim the foregoing invention, I have hereunto set my hand this 2nd day of February, 1920.

LOUIS A. ANDREWS.