

(No Model.)

2 Sheets—Sheet 1.

G. E. TREGURTHA.
VAPORIZER.

No. 578,683.

Patented Mar. 9, 1897.

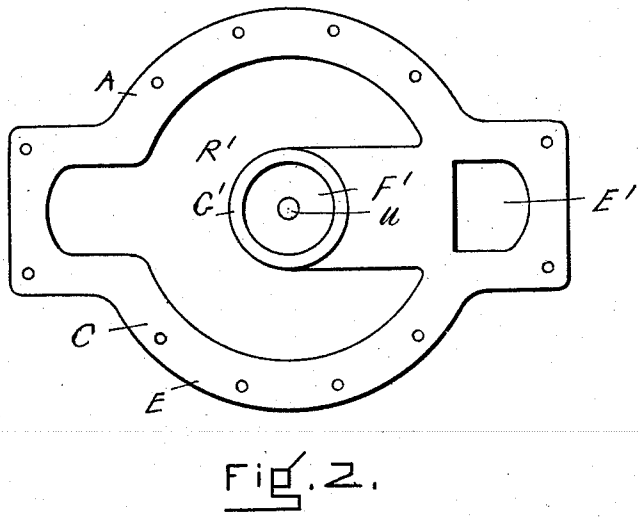
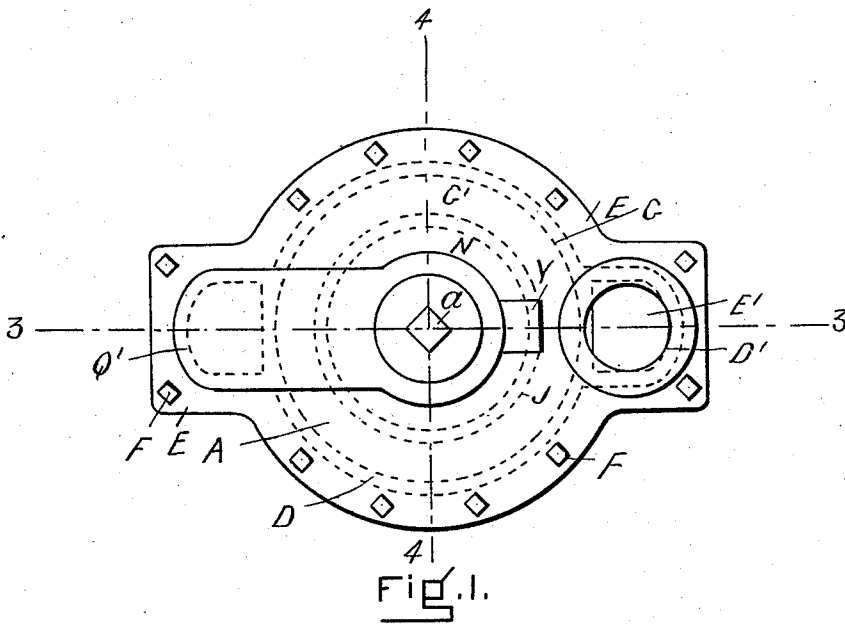

WITNESSES
Edmund C. Hines
J. J. Macken

INVENTOR
Genex B. Tregurtha
Per Edwin W. Brown,
Attorney.

UNITED STATES PATENT OFFICE.

GEORGE E. TREGURTHA, OF MALDEN, MASSACHUSETTS.

VAPORIZER.

SPECIFICATION forming part of Letters Patent No. 578,683, dated March 9, 1897.

Application filed April 29, 1896. Serial No. 589,564. (No model.)

To all whom it may concern:

Be it known that I, GEORGE E. TREGURTHA, of Malden, in the county of Middlesex and State of Massachusetts, have invented certain new and useful Improvements in Vaporizers, of which the following is a full, clear, and exact description.

This invention relates to a vaporizer for vaporizing gasolene and similar liquids, for use more particularly in connection with the operation of an engine; and the invention consists of a vaporizer constructed and arranged for vaporizing gas from gasolene or other liquids, all substantially as hereinafter fully described, reference being had to the accompanying sheets of drawings, in which—

Figure 1 is a plan view. Fig. 2 is a view below section-line 2 2, Fig. 3. Figs. 3 and 4 are vertical central sections on lines 3 3 and 4 4, respectively, Fig. 1. Fig. 5 is a cross-section on line 5 5, Fig. 4.

In the drawings, A represents a casing or shell made of any suitable metal, circular in cross-section, and made in three parts—B, a central portion; C, a lower portion, and D, a top or cover, all secured together by flanges E and screws F, respectively.

G is an annular chamber formed by the outer wall H and inner circular wall J, cover D, and a bottom K, connecting the two walls together. The inner circular wall J is not so high as the outer wall H, leaving a space L over its upper end between it and the cover D.

M is a horizontal partition within the inner wall, dividing it into two chambers N P.

From the central part of the top or cover D extends downward a circular partition Q a short distance into the upper chamber N, making an air-passage R, and above this passage the top of the cover extends upward, forming a chamber or passage S above the air-passage R, and practically a continuation or a part of it, and this upper part has a contracted opening T, into the upper end of which is arranged to screw a short tube U, its upper part being enlarged, as at V, and into the upper end of which is screwed a cap or hollow plug W, having a square head *a* on its outside, by which to turn it in and out.

The enlarged portion V of the short tube U has a side tubular extension Y, the outer end of which is adapted to receive a pipe leading from the gasolene-supply.

Through one side of the plug W is a hole *b*, which opens into the chamber *d* of the plug, and which when the plug is screwed down in place is opposite to or coincident with a hole *e* in the side of the tube, opening into the chamber *f* of the side extension Y.

A' is tapering valve adapted to fit a corresponding seat B' in the tube U, and it is centrally secured to a stem or rod *g*, the lower end of the valve extending down and projecting a short distance below into the chamber S. The upper part of the rod or stem *g* extends up through the tube and freely through a screw-nut *n*, screwed into the tube, which serves as a guide for the valve-stem *g*. In the chamber of the tube above the valve-seat B' is a spiral spring C' surrounding the upper stem and bearing against the under side of the screw-nut *n* and the upper end of the valve A', which spring acts to hold and return the valve to its seat.

At one side in the top is a raised portion D', which has communication with and forms an upward extension of a vertical passage E' in the side of the middle portion outside of the annular chamber, and in its open end is adapted to be screwed a pipe or conductor, (not shown,) which leads to any suitable hot-air supply, such, for instance, as the jacket-chamber of the cylinders.

The vertical side passage E' at its lower end opens into the end of a horizontal passage F' in the bottom part, leading toward the center, and opening by its upper end G' in a circular form in the lower chamber P, which end forms a seat for a flat circular valve H'. This valve H' is secured centrally to a vertical stem or rod *r*, its lower portion *t* extending down through a central opening *u* in the wall J' of the casing and having on its outer end *v* a screw-nut K', which can be screwed up and down thereon and thus regulate by its abutment against the end *w* of the case the upward movement of the valve H' from its seat.

The upper part *x* of the valve-stem *r* extends up through a central opening *z* in a central post L', rising from the partition M, forming a guide for the movements of the valve with the bottom opening *u*. On the upper end of this stem *x* is a horizontal disk or circular plate M', its upper side being slightly convex, and when the valve H' is on its seat it projects a short distance into the

air-passage S, as shown, and a short distance below the lower end *h* of the valve A' when it is on its seat, as shown.

The passage S extends along horizontally at one side, as at P', Fig. 3, in the top D, and opens into a vertical passage Q' outside of the annular chamber G, which at its lower end communicates with a horizontal passage and chamber R' in the bottom, which opens into the chamber P under the central partition M, as shown more particularly in Fig. 3.

In the outside wall is an opening or outlet S', having an internal screw-thread, into which can be screwed a pipe to lead to the engine to be operated by the gasolene.

The operation of the vaporizer is as follows: Heated air is drawn in the usual manner into the vaporizer through the opening D', which passes down through the passage E' into the passage F', up the central passage, raising the valve H' from its seat, which lets the heated air into the chamber P, when it passes along the horizontal passage R', up the passage Q', along the upper passage P', around and about the disk M', and into the several air-passages and chamber below it. As the valve H' rises from the passage of the hot air its disk M' strikes against the lower end of the valve A', raising the valve from its seat, leaving the passage therearound free for the gasolene to flow down therethrough, which in the meantime has passed through the holes *b e* into the plug-chamber *d*, into the passage S below the valve, and drops onto the disk M', which has become heated. The gasolene becomes more or less heated and vaporized and in its vapor form passes down the annular passage R, into the chamber N, over the upper edge of its wall J, into the annular chamber G, and then out at the outlet S' to the engine. If any of the gasolene passing into the chamber N is not vaporized, it passes through a hole *a'* in the partition M into the chamber P, and is then vaporized on the valve H', which passes through the passages R', Q', and P' into the central chamber N and, with the other vapor, out at the exit. If any gasolene in the chamber P and passage R is not vaporized, it passes out through a small opening *b'* in the bottom and escapes into the air.

In the use of this vaporizer with an engine it is preferable to have it connected thereto so that the heated air will pass into the vaporizer at intervals, the valve to the heated-air pipe being operated in any of the well-known ways in the operation of gasolene-engines and preferably at every other outward stroke of the piston, although it is not limited to such. Thus at every other outward stroke of the engine the heated air is drawn into the vaporizer, opening the two valves, vaporizing the gasolene, the vapor of which passes, as described, to the engine to be ignited in any of the usual ways, when, the heated air being shut off with the inward stroke, the valves A and H' are closed until the next operating

outward stroke, when the valves are operated and the gasolene vaporized as before, and so on as long as desired.

The air-passage extending nearly around the vaporizing-chambers before communicating therewith, the heated air as it passes therethrough comes in contact with nearly all the walls of the chambers before entering therein, which warms the walls and thus quickens and insures the vaporizing of the gasolene therein.

Having thus described my invention, what I claim is—

1. In a vaporizer, a series of vaporizing annular chambers, concentric with each other, an outlet to the outer annular chamber, an air-passage leading to the central annular chamber extending nearly around the chambers, a valve to said air-passage, an inlet for the gasolene into the end of said air-passage, a valve to said inlet, a disk or plate in the end of said air-passage below said gasolene-valve and connected to said air-valve for operation thereof.

2. In a vaporizer, a series of vaporizing-chambers, consisting of a central annular chamber open at its top, and open at its bottom into an outer annular chamber, the latter annular chamber open at its top into the third and outer annular chamber, the annular chambers being concentric with each other, an outlet to the outer annular chamber, an air-passage leading to the central annular chamber extending nearly around the chambers, a valve to said air-passage, an inlet for the gasolene into the end of said air-passage, a valve to said inlet, a disk or plate in the end of said air-passage below said gasolene-valve and connected to said air-valve for operation thereof.

3. In a vaporizer, vaporizing-chambers, an outlet thereto, an air-passage leading to the vaporizing-chambers extending nearly around the same, a valve to said air-passage, an inlet for the gasolene into the end of said air-passage, a valve to said inlet, a disk or plate in the end of said air-passage below said gasolene-valve and connected to said air-valve for operation thereof.

4. In a vaporizer, vaporizing-chambers, an outlet thereto, an air-passage leading to the vaporizing-chambers extending nearly around the same, an escape-outlet to said air-passage, a valve to said air-passage, an inlet for the gasolene into the end of said air-passage, a valve to said inlet, a disk or plate in the end of said air-passage below said gasolene-valve and connected to said air-valve for operation thereof.

In testimony whereof I have hereunto set my hand in the presence of two subscribing witnesses.

GEORGE E. TREGURTHA.

Witnesses:

EDWIN W. BROWN,
LEONA C. ARNO.