

(21) Application No: 2201519.2

(22) Date of Filing: 07.02.2022

(71) Applicant(s):
Intumescent Systems Ltd
Envirograf House, Barrestone, DOVER, Kent,
CT15 7JG, United Kingdom

(72) Inventor(s):
Derek Alfred Ward

(74) Agent and/or Address for Service:
Agile IP LLP
Airport House, Purley Way, Croydon, Surrey,
CR0 0XZ, United Kingdom

(51) INT CL:
F24F 7/10 (2006.01) A62C 2/06 (2006.01)
E04B 1/70 (2006.01) E04B 1/94 (2006.01)
E04C 1/39 (2006.01) F24F 7/04 (2006.01)
F24F 13/10 (2006.01)

(56) Documents Cited:
GB 2510900 A GB 2472146 A
GB 2312842 A FR 002254182 A5
JP H09159257 A

(58) Field of Search:
INT CL A62C, E04B, E04C, E06B, F24F
Other: WPI, EPODOC

(54) Title of the Invention: **Air ventilation apparatus**
Abstract Title: **Air ventilation apparatus with means to prevent the spread of fires**

(57) An air ventilation apparatus for passing through a cavity wall (16, 18 fig 5) of a building comprises a central duct 14 located between front 10 and rear 12 brick shaped ducts each having apertured cover plates 20, (24, fig 2) attached to each end of the ducts and through which air is ventilated. One 24 of the cover plates has a shutter to selectively open, partially close or close the aperture(s), and wherein the shutter includes an intumescent coating or lining to prevent the spread of fires. The ducts may be metallic and comprise powder coated zinc. The central duct may be inclined relative the front and rear ducts (fig 6). A detachable closure panel (30, fig 3) for selective attachment to the cover plate 20 may be used to close off the ducts in the event of a flood.

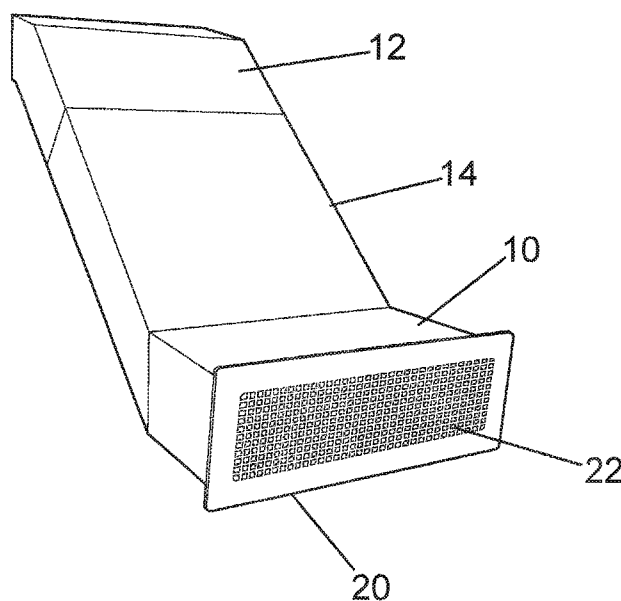

Fig. 1

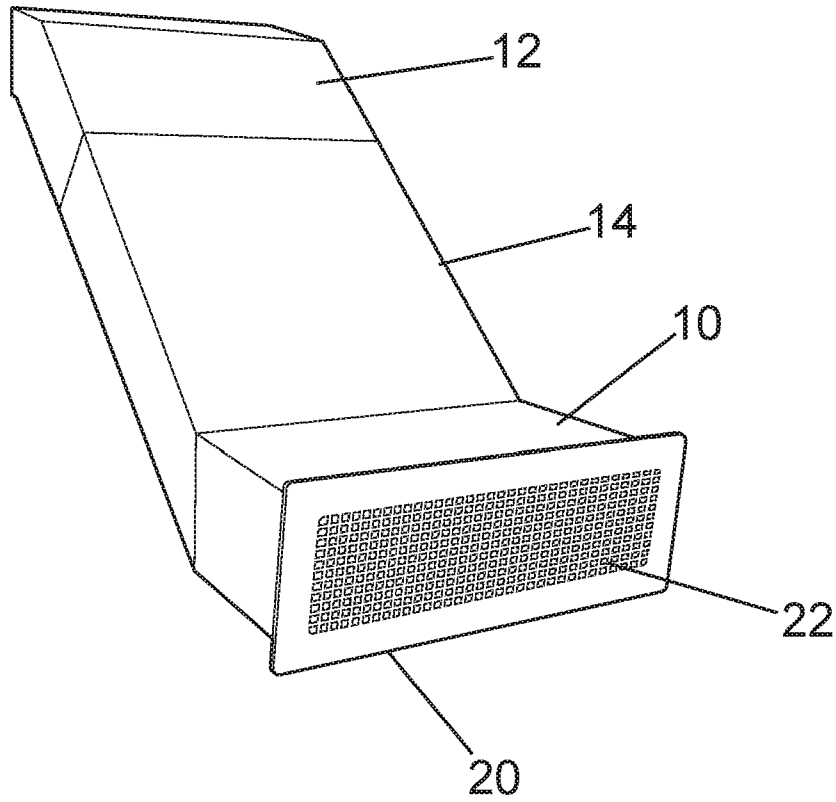

Fig. 1

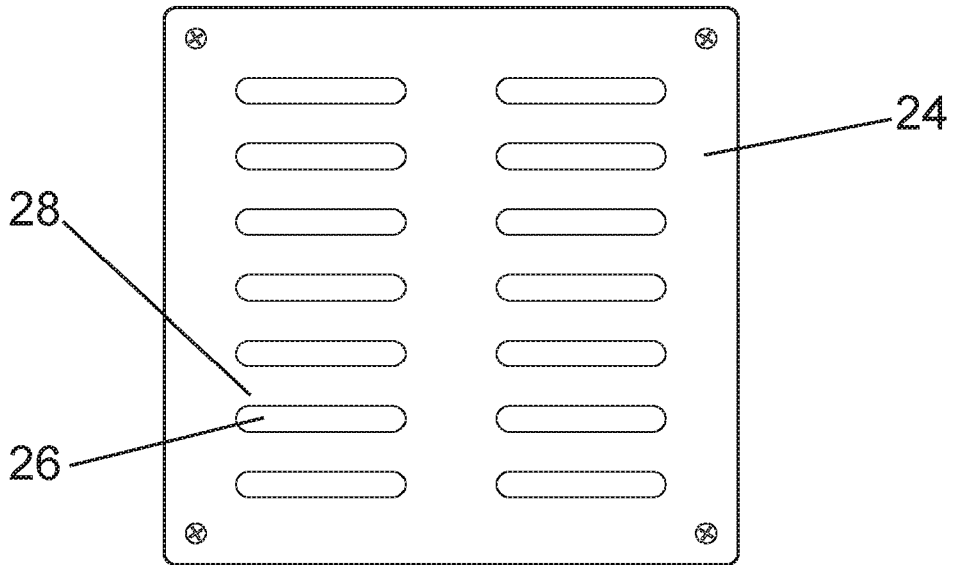

Fig. 2

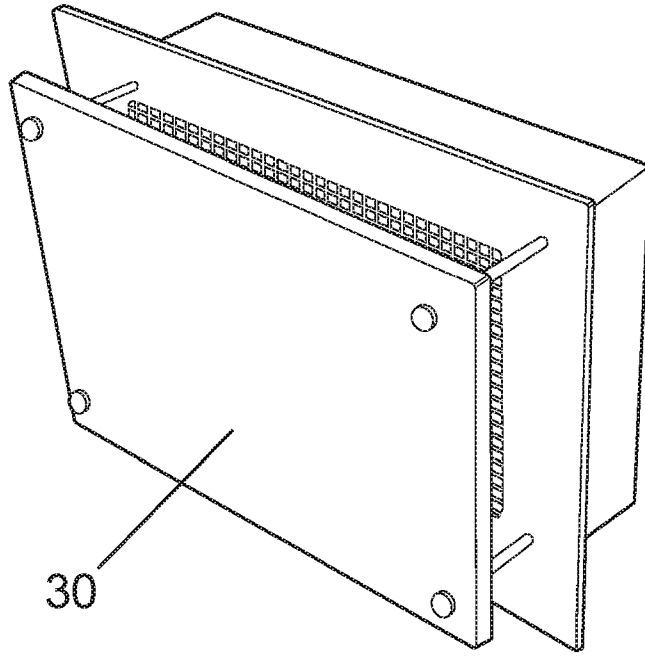

Fig. 3

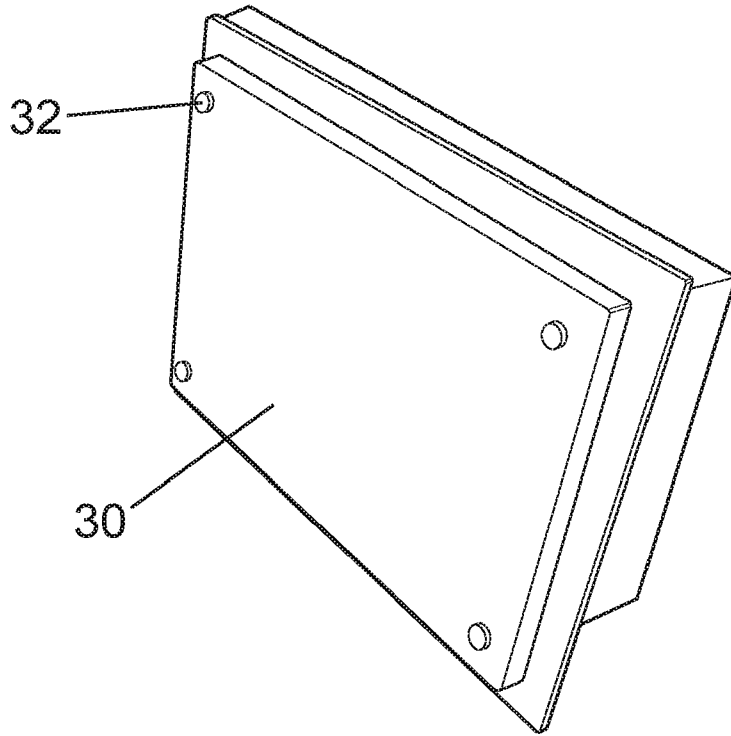

Fig. 4

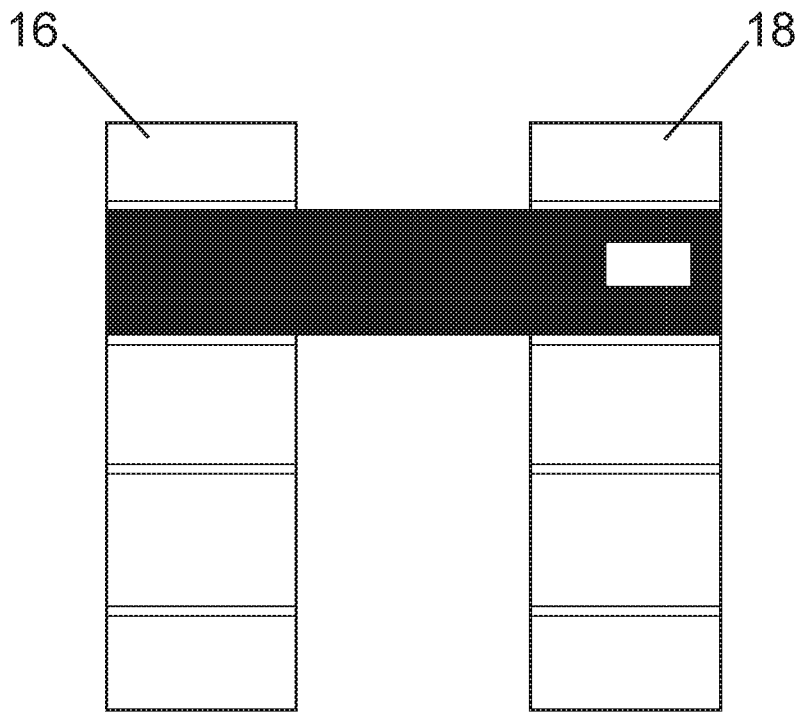

Fig. 5

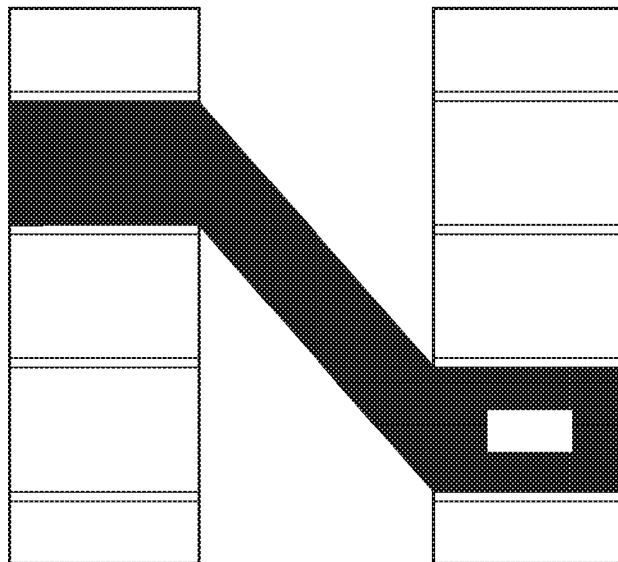

Fig. 6

AIR VENTILATION APPARATUS

FIELD OF THE INVENTION

This invention relates to air ventilation apparatus for location between cavity walls of a building.

5

BACKGROUND TO THE INVENTION

Through-wall air venting apparatus for location between cavity walls of buildings is known which provides effective air circulation and protection against external dampness permeating the internal walls of a building.

10

It is also known that the cavities created between internal and external walls of a building themselves define relatively open spaces through which smoke and flames can spread rapidly from a fire source to other areas of the building. Presently available air vents are unable to prevent the spread of fire within a building and, indeed, in many cases facilitate such spread.

15

The present invention sets out to provide air venting apparatus which overcomes many of the disadvantages of presently available air ventilation apparatus.

STATEMENTS OF THE INVENTION

20 In one aspect the invention provides air ventilation apparatus for location between internal and external cavity walls of a building, the apparatus comprising an open-ended metallic housing which includes front and rear brick shaped section each including an outer panel formed with a plurality of ventilation apertures, and a central open-ended tubular section to which the ends of the front and rear sections remote from the brick shaped sections are connected, the outer
25 panel of said rear brick-shaped section including a shutter operable selectively to open, partially close or close the openings of the rear section, said shutter including a coating or lining of intumescent material.

30 Preferably the open-ended housing of the ventilation apparatus is produced from powder coated Zintec metal.

The central section may be inclined relative to the front and rear sections.

35 The openings of the outer panel of the front brick shaped section may comprise a plurality of relatively small preferably round holes dimensioned to prevent rodents entering the ventilation apparatus. Preferably, these holes extend across substantially the entire face of the outer panel.

The outer panel of the front section may be bordered by an upstanding lip which, in use of the apparatus, lies in contact with the outer cavity wall in which it is located.

- 5 The openings of the panel of the rear brick-shaped section may comprise a plurality of slot-shaped openings each closable by said shutter.

A detachable closure panel for selective attachment to the outer panel may be provided s to close off the outer panel of the rear section of the ventilation apparatus.

10

BRIEF DESCRIPTION OF THE DRAWINGS

The invention will now be described with reference to the accompanying diagrammatic drawings in which:-

- 15 Figure 1 is an isometric view of air ventilation apparatus in accordance with the invention;

Figure 2 is a plan view of a face plate of ventilation apparatus in accordance with the invention;

- 20 Figures 3 and 4 are isometric views of closure plates for the illustrated ventilation apparatus; and

Figures 5 and 6 are diagrammatic side views illustrating two examples of air ventilation apparatus in accordance with the invention in situ between cavity walls of a building.

25 DETAILED DESCRIPTION OF THE INVENTION

- The ventilation apparatus illustrated in the drawings is for location within adjoining cavity walls of a building and comprises a brick-shaped metallic front tubular section 10 for location within an external cavity wall of a building, a brick-shaped rear tubular section 12 for location within the adjacent internal cavity wall and a similarly shaped central tubular section 14 which
30 interconnects the front and rear sections.

Thus, in combination, the sections 10, 12 and 14 together provide an uninterrupted airflow conduit between the outermost faces of adjacent cavity walls of a building.

- 35 As shown in Figures 5 and 6 of the drawings, depending on the locations of respective openings formed in the adjoining cavity walls 16, 18, the central section 14 may be positioned

generally horizontally in line with the sections 10, 12 or inclined with respect to the sections 10, 12.

5 The dimensions and common shapes of the sections 10, 12 and 14 enable the ends of the section 14 to slidingly engage the adjoining ends of the sections 10 and 12 and to provide a limited ability to vary the overall length of the assembly.

The metallic sections 10, 12 and 14 are preferably produced from a Zintec powder coated steel.

10

The front section 10 of the ventilation apparatus includes a cover plate 20 formed with a multiplicity of ventilation apertures 22. Similarly, the rear section 12 includes a cover plate 24 which, as for the cover plate 20, is formed with a plurality of ventilation apertures 26. The ventilation apertures 22 are intentionally small to prevent small rodents and debris passing from one side of the cavity wall to the other side.

15

The height and width of the cover plate 20 are preferably larger than the height and width of the opening into which the section 10 locates to define a border which abuts against the respective areas of the cavity wall.

20

The rear section 12 is covered by a closure plate 24 as illustrated in Figure 2. The closure plate 24 includes a shutter 26 which locates behind a slotted grill 28 and is movable relative to the closure plate to open, partially close and fully close the openings to control the volume of air passing from one side of the cavity wall to the other.

25

The shutter and/or the closure plate 24 are coated with a material which intumesces in the presence of excessive heat or fire to fully close off the ventilation openings of the grill 28. Alternatively, or additionally, the inner walls of the rear section 12 may be lined or coated with an intumescent material.

30

As illustrated in Figures 3 and 4, in the event of potential flooding or like inclement weather, the ventilation apertures 22 of the tubular section 10 may be closed by a plate 30 which can selectively be secured to the plate 16 by suitable fittings 32.

35

It is to be understood that the foregoing is merely exemplary of air venting apparatus in accordance with the invention and that modifications can readily be made thereto without departing from the true scope of the invention as set out in the appended claims.

CLAIMS

1. Air ventilation apparatus for location between internal and external cavity walls of a building, the apparatus comprising an open-ended metallic housing which includes
5 front and rear brick shaped section each including an outer panel formed with a plurality of ventilation apertures, and a central open-ended tubular section to which the ends of the front and rear sections remote from the brick shaped sections are connected, the outer panel of said rear brick-shaped section including a shutter operable selectively to open, partially close or close the openings of the rear section,
10 said shutter including a coating or lining of intumescent material.
2. Apparatus as claimed in claim 1 wherein the open-ended housing of the ventilation apparatus is produced from powder coated Zintec metal.
- 15 3. Apparatus as claimed in claim 1 or claim 2 wherein the central section is inclined relative to the front and rear sections.
4. Apparatus as claimed in any one of the preceding claims wherein the openings of the
20 outer panel of the front brick shaped section comprise a plurality of relatively openings.
5. Apparatus as claimed in claim 4 wherein the openings extend across substantially the entire face of the outer panel.
- 25 6. Apparatus as claimed in any one of the preceding claims wherein the outer panel of the front section is bordered by an upstanding lip which, in use of the apparatus, lies in contact with the outer cavity wall in which it is located.
- 30 7. Apparatus as claimed in any one of the preceding claims wherein the openings of the panel of the rear brick-shaped section comprise a plurality of slot-shaped openings each closable by said shutter.
- 35 8. Apparatus as claimed in any one of the preceding claims wherein a detachable closure panel for selective attachment to the outer panel is provided to close off the outer panel of the rear section of the ventilation apparatus.

Amendments to the claims have been filed as follows.

CLAIMS

1. Air ventilation apparatus for a cavity wall structure which comprises an internal wall and an external wall separated by a cavity, the apparatus comprising an open-ended metallic housing which includes front and rear brick shaped sections each including a cover plate formed with a plurality of ventilation apertures, and a central open-ended tubular section to which the ends of the front and rear sections remote from the brick-shaped sections are slidingly engaged to enable the length of the housing to be varied, the outer panel of said rear brick-shaped section including a shutter operable selectively to open, partially close or close the ventilation apertures of the rear section, said shutter including a coating or lining of intumescent material.
2. Apparatus as claimed in claim 1 wherein the open-ended metallic housing is produced from powder coated Zintec metal.
3. Apparatus as claimed in claim 1 or claim 2 wherein the central open-ended tubular section is inclined relative to the front and rear sections.
4. Apparatus as claimed in any one of the preceding claims wherein the cover plate of the front section is bordered by an upstanding lip which, in use of the apparatus, lies in contact with the outer cavity wall in which it is located.
5. Apparatus as claimed in any one of the preceding claims wherein the openings of the cover plate of the rear brick-shaped section comprise a plurality of slot-shaped openings each closable by said shutter.
6. Apparatus as claimed in any one of the preceding claims wherein a detachable closure plate for selective attachment to the outer panel

30 06 23

5

10

15

20

25



Application No: GB2201519.2

Examiner: Stephen Hart

Claims searched: 1 - 8

Date of search: 19 July 2022

Patents Act 1977: Search Report under Section 17

Documents considered to be relevant:

Category	Relevant to claims	Identity of document and passage or figure of particular relevance
Y	1 - 8	FR 2254182 A5 (VERSINO) see figs 1 - 4 and unofficial English translation of page 3, lines 1 - 9, noting a ventilation duct having moveable blades 2 coated with an intumescent material.
Y	1 - 8	GB 2312842 A (ENVIRONMENTAL SEALS LTD) see figs 1 - 3 and page 3 line 30 - page 5 line 18, noting a grill 1 for placing over an opening in a door, ceiling or wall and comprising a sliding plate 4 to open and close slots 2, and the plate having an intumescent material bonded thereto.
Y	1 - 8	GB 2510900 A (VKR HOLDING AS) see fig 7, noting an air transfer arrangement comprising a grille 54, rectangular housing 46, rectangular enclosure 42, intumescent damper 56, rectangular frame 60 and grille 60.
Y	8	GB 2472146 A (CLARKE) see whole document, noting an air brick flood cover comprising a panel member 16 for releasably attaching to an air brick 12 to prevent flood water ingress into a building.
A		JP H09159257 A (MISAWA HOMES CO) see figs 1 - 5, noting a building ventilation structure formed in a wall 15 having louvres 51 coated with intumescent material 43.

Categories:

X	Document indicating lack of novelty or inventive step	A	Document indicating technological background and/or state of the art.
Y	Document indicating lack of inventive step if combined with one or more other documents of same category.	P	Document published on or after the declared priority date but before the filing date of this invention.
&	Member of the same patent family	E	Patent document published on or after, but with priority date earlier than, the filing date of this application.

Field of Search:

Search of GB, EP, WO & US patent documents classified in the following areas of the UKC^X :

--

Worldwide search of patent documents classified in the following areas of the IPC

A62C; E04B; E04C; E06B; F24F

The following online and other databases have been used in the preparation of this search report



WPI, EPODOC

International Classification:

Subclass	Subgroup	Valid From
F24F	0007/10	01/01/2006
A62C	0002/06	01/01/2006
E04B	0001/70	01/01/2006
E04B	0001/94	01/01/2006
E04C	0001/39	01/01/2006
F24F	0007/04	01/01/2006
F24F	0013/10	01/01/2006