

July 30, 1963

E. BLONDIAU

3,099,189

DEFORMABLE DIAPHRAGM APPARATUS

Filed July 14, 1960

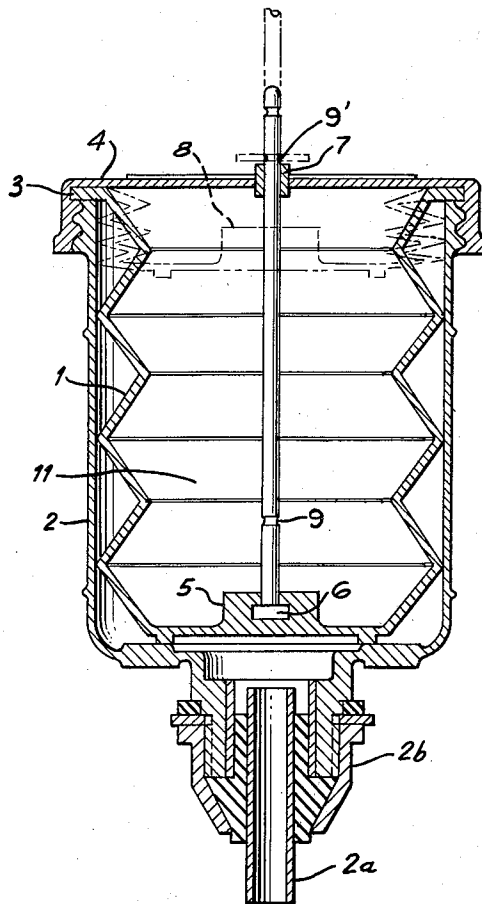

INVENTOR.
EDGARD BLONDIAU

BY

ATTORNEY

1

3,099,189

DEFORMABLE DIAPHRAGM APPARATUS

Edgard Blondiau, Ile-St.-Denis, France, assignor to
Societe STOP, Saint-Ouen, France, a corporation of
France

Filed July 14, 1960, Ser. No. 42,879

Claims priority, application France Sept. 16, 1959

4 Claims. (Cl. 92—23)

The present invention relates to fluid reservoirs for feeding hydraulic circuits, notably those of braking systems for vehicles, and it is the specific object of this invention to provide a deformable diaphragm for isolating from the atmosphere or the surrounding medium a reserve of fluid feeding a hydraulic system, notably the hydraulic control circuit of the braking systems of vehicles.

The diaphragm forming the subject-matter of this invention is intended mainly for avoiding the contamination of the fluids utilized in hydraulic transmissions which are hydrophilic, as a rule.

The hydrophilic character of these fluids tends to alter their state and due to this fact their physical properties are modified to a very substantial extent according to the percentage of water absorbed thereby. The presence of this absorbed water reduces more particularly their boiling point as well as their resistance to oxidation by hydrolysis.

The hydrolysis phenomenon is not controllable in spite of the addition of buffer agents to the fluids with a view to impart stability and corrosion-resisting properties thereto.

The consequences of this hydrolysis become apparent with time but it generally entails immediate disadvantages of lesser importance such as the reduction in the boiling point of the fluid utilized.

Reports on research works concerning the modifications brought by the absorption of water by the fluids utilized in hydraulic braking systems have repeatedly been published.

These results have been discussed and criticized notably in automobile technical papers.

The conclusions to which these studies have led do not meet completely the conditions set up with a view to finding a satisfactory solution to this problem, for in spite of the adoption of fluids having a very high boiling point their contamination by water still remains the cause of major disadvantages such as the reduction of the boiling point and the hydrolysis of the fluid, which results in a systematic corrosion of all the component elements of the system.

By using the diaphragm constituting the subject-matter of the present invention it is possible to isolate completely from the atmosphere and the surrounding medium the reserve of fluid in the system and to prevent it from becoming contaminated by water from the outside.

This isolation is effected in an elastic manner so that the fluid level in the reserve space may follow the variations in the requirements of the control circuits.

Accordingly it is an object of the invention to provide a deformable diaphragm for use in a fluid reservoir system which will follow variations in the fluid level of the reservoir while isolating the fluid therein from contaminants outside the system.

It is a further object of the invention to provide an elastic diaphragm capable of exerting pressure on the reservoir system.

It is a still further object to provide a deformable diaphragm for a fluid reservoir system with a withdrawal rod communicating with the interior of said diaphragm.

The above and further objects of the invention will be

2

better appreciated from the following specification and claims read in conjunction with the following drawing.

The single FIGURE of the attached drawing illustrates in diagrammatic axial section a fluid reservoir provided with an elastic diaphragm according to this invention which, in the example illustrated, is a bellows or like member having an accordion-like structure.

Referring to the drawing, it will be seen that the bellows-shaped diaphragm 1 is mounted in a conventional fluid reservoir 2 for feeding a hydraulic braking system (not shown) through connecting pipe 2a which communicates with the reservoir at the bottom and which is fastened thereto by a suitable pipe coupling 2b, this reservoir being adapted to contain the fluid reserve which the diaphragm contacts with its outer surface.

The upper portion of this resilient bellows comprises an outwardly directed flange 3 constituting a fluid tight sealing joint or gasket between a cover 4 and the upper edge of the reservoir 2. This cover 4 may be secured on the reservoir by screwing or otherwise.

The bottom portion of diaphragm 1 is formed with an integrally moulded inner central boss 5 having fitted therein the head of a central rod 6. This rod 6 slides freely through a central orifice 7 formed in the cover 4.

The upper portion of the central rod 6 emerges from the cover 4 and may carry marks indicating the level of the fluid contents in the reservoir since the bottom of the bellows 1 contacts the fluid in the reservoir.

The main function of the central rod 6 is to permit the withdrawal of diaphragm 1 upon the filling of the reservoir and, upon completion of this operation, the fitting of the cover 4 is replaced on the reservoir 2.

To permit the fitting of the cover 4 on the reservoir 2 after the latter has been filled with fluid, it is necessary that the deformable diaphragm 1 does not exert any piston-like thrust upon the liquid surface before the flange 3 has actually sealed the joint between the reservoir and the cover.

To this end, the rod 6 may be provided with a circular groove or notch 9 for retaining and positioning the diaphragm or bellows 1 in its uppermost position 8 as shown in broken lines in the drawing, wherein the bellows is folded and located close to the cover 4. Thus, when the bellows 1 is compressed, the groove or notch 9 is flush with the upper face of the cover 4.

A retaining pin or circlip 9' is threaded in the groove 9 and is adapted to hold the bellows 1 in its compressed condition during the fitting and removal of the cover 4 with respect to the reservoir for performing the filling operation.

Upon completion of this filling operation, the pin or circlip 9' is removed or slipped upward toward the upper end of rod 6, the latter being formed if desired with another groove or notch 10 for receiving the retaining pin or circlip. It will be apparent that a maximum amount of fluid may be introduced into the vessel 2 because of the minimum amount of fluid displaced by the diaphragm in its deformed position after replacement of the cover 4 over the vessel.

The essential function of the bellows 1 is to follow the liquid level according to the demand from the hydraulic circuits connected to the reservoir 2.

This bellows may be made from any suitable flexible or resilient waterproof material. Thus, elastic rubber or polyvinyl chloride may be used, but other suitable materials known to those skilled in the art may also be used.

The bellows 1 may also be provided with an inner loading spring. This spring may be placed within the space 11 communicating with the atmosphere through the orifice 7 formed in the cover 4.

Another solution to the problem of producing a load

effect by means of a bellows 1 consists in utilizing materials adapted to impart resilient properties to this bellows 1 while creating a hydrostatic pressure on the diaphragm by the liquid contained in the reservoir 2.

This pressure is determined by the resilient properties of the bellows 1 and may be utilized with the maximum efficiency in the hydraulic control circuits of automobile braking systems.

The presence of a column of liquid under pressure in the brake control circuit constitutes a valuable factor for the pressure maintenance of the proper fluid-tightness of the seals and packings in the circuit so as to prevent the undesirable ingress of air and the water-contamination of the circuit.

Of course, the present invention should not be construed as being limited to the arrangement of a bellows in the fluid reservoir, for any deformable diaphragm having the requisite elastic and sealing properties may be used in lieu thereof.

While I have described above the principle of my invention in connection with specific apparatus, it is to be clearly understood that this description is made only by way of example and not as a limitation to the scope of my invention.

What is claimed is:

1. Filling and isolating apparatus for a hydraulic system comprising a fluid reservoir vessel having an output port in communication with said hydraulic system, a deformable diaphragm adapted to fit within the body of said vessel and to exert pressure on the fluid in said vessel, a removable cover for the top of said vessel, said cover being provided with a central aperture extending therethrough, said diaphragm comprising a bellows having an open end and a closed end, said open end having an outwardly extending flange adapted to be retained in hermetic sealed relation between the lip of said vessel and the inside of said cover, a rod fastened to the inside

of the closed end of said bellows, said rod adapted to extend through the aperture in said cover, a slot in said rod running in a direction normal to the longitudinal axis of said rod, and restraining means adapted to be fitted within said slot after said rod has been partially drawn through said cover in a direction opposite from the interior of said vessel, whereby to temporarily maintain said diaphragm in deformed position against the inside portion of said cover when said cover is removed from said vessel so that the volume of fluid which may be introduced into said vessel is subject to minimum displacement by said diaphragm after such introduction and the replacement of said cover over said vessel.

2. Apparatus as claimed in claim 1, wherein said rod is circular in cross section and the slot therein is radial and extends circumferentially therearound.

3. Apparatus as claimed in claim 1, wherein said vessel and said bellows are circular, said bellows being made of a resilient material and having an outside diameter in either its normal or deformed positions substantially equal to the inside diameter of said vessel.

4. Apparatus as claimed in claim 1 wherein the slot in said rod is positioned along the length thereof at a distance from the bottom end of said diaphragm equal to the length of said diaphragm in its maximum deformed position.

References Cited in the file of this patent

UNITED STATES PATENTS

1,174,232	Copeland	Mar. 7, 1916
1,541,187	Roote	June 9, 1925
1,691,441	Kennedy et al.	Nov. 13, 1928
1,905,583	Giesler	Apr. 25, 1933
2,315,212	Kronmiller et al.	Mar. 30, 1943
2,939,471	Fay	June 7, 1960