

(19)



(11)

**EP 2 987 945 B1**

(12)

**EUROPEAN PATENT SPECIFICATION**

(45) Date of publication and mention  
of the grant of the patent:  
**31.01.2018 Bulletin 2018/05**

(51) Int Cl.:  
**E21B 4/14 (2006.01) B25D 9/16 (2006.01)**

(21) Application number: **14181371.7**

(22) Date of filing: **19.08.2014**

(54) **HYDRAULIC STRIKING DEVICE**

HYDRAULISCHER SCHLAGHAMMER

MARTEAU À COUP HYDRAULIQUE

(84) Designated Contracting States:  
**AL AT BE BG CH CY CZ DE DK EE ES FI FR GB  
GR HR HU IE IS IT LI LT LU LV MC MK MT NL NO  
PL PT RO RS SE SI SK SM TR**

(43) Date of publication of application:  
**24.02.2016 Bulletin 2016/08**

(73) Proprietor: **Doofor Oy**  
**37150 Nokia (FI)**

(72) Inventor: **Hämäläinen, Jaakko**  
**33300 TAMPERE (FI)**

(74) Representative: **Papula Oy**  
**P.O. Box 981**  
**00101 Helsinki (FI)**

(56) References cited:  
**US-A- 4 172 411 US-A- 5 056 606**  
**US-A- 5 277 264 US-A- 5 715 897**  
**US-A1- 2004 188 146 US-B1- 6 799 641**

**EP 2 987 945 B1**

Note: Within nine months of the publication of the mention of the grant of the European patent in the European Patent Bulletin, any person may give notice to the European Patent Office of opposition to that patent, in accordance with the Implementing Regulations. Notice of opposition shall not be deemed to have been filed until the opposition fee has been paid. (Art. 99(1) European Patent Convention).

## Description

### FIELD OF THE INVENTION

[0001] The present invention relates to a hydraulically striking device and components used for striking on a material hydraulically for example in rock drilling or similar applications.

### BACKGROUND OF THE INVENTION

[0002] One example of hydraulically striking devices comprises a piston that hydraulically reciprocates between a first position and a second position. The movement is controlled hydraulically with a controlling arrangement which is in connection with the device. The controlling arrangement may include a valve, for example inside the device and the connections to the piston.

[0003] Hydraulically striking devices are used in the hydraulic machines that are for example working in the rock drilling or similar applications. Rock drilling is usually performed in mines and construction plants. In some of the mining plants it is not uncommon that they can produce hundreds of thousands of tons of ore from the rock in a year. The hydraulically striking device is also used for drilling and sampling, general excavations, tunneling work and roof bolting. On the work site, the hydraulically striking device can be used for drilling of rock. One example of test results of one rock drilling equipment working on the drilling site shows typical operating values of the machine equipped with one model-size hydraulically striking device such as a penetration rate of around 2 meters/minute in granite with a drill hole diameter of around 50 mm when using a percussion pressure from around 100 bar up to 200-300 bar. On the drill site, around or over 100 mm holes are not uncommon for the rock drilling equipment.

[0004] Usually, a controlling arrangement such as a valve is provided inside the hydraulically striking device and is designed to last in the hard working environment of the machine. The valve is usually larger than a standard-size screw-in cartridge valve, robust and strongly built, as the hydraulically striking device can strike generally from 30 to 100 times in a second. The device can weigh up to hundreds of kilos. But in the future, bigger and heavier models are needed when the demands from the industry rise. Also, demands for a higher striking force with lower flows raise the demands for the equipment so that the operating pressures of the hydraulically striking device can be at a relatively high level.

[0005] A common problem is that the hydraulic fluid controlling the piston does not change completely or the amount of hydraulic fluid changed is insignificant in the controlling arrangement. The hydraulic fluid, for example hydraulic oil, vibrates back and forth between the piston and the controlling arrangement and creates cavitation that damages the device and the whole hydraulic system. The cavitating fluid causes the air bubbles in the fluid to

explode rapidly, further mechanically removing particles such as metal chips from the structure. This may destroy the components in contact with the fluid. When the fluid does not circulate, the reciprocating movement causes the fluid to move back and forth and the fluid between the piston and the control arrangement does not change.

[0006] The fluid being essentially in the same position is more likely to wear the structures in use. Cavitation occurs especially when there is no adequate circulation of the hydraulic fluid. The temperature of the hydraulic fluid in these segments of the hydraulic circuit reaches a higher level than normally. Fluid that is at a higher temperature than normally is more likely to cavitate. When the device is assembled, a substantial amount of air is usually trapped in the hydraulic circuit. After the startup, it is essential to remove the air from the circuit of the device. If the trapped air is not removed, it will be mixed to the hydraulic fluid which leads to easier cavitation. The air in the device also causes delay in the operation of the valve as the air is compressible. Cavitation also occurs in situations where a substantially low pressure hydraulic fluid flows with substantially high flow rate from the device to the tank, particularly when the flow suddenly stops.

[0007] One example of a hydraulically striking device is disclosed in reference US 5 715 897 A.

### OBJECTIVE OF THE INVENTION

[0008] The objective of the invention is to eliminate or at least alleviate the problems mentioned above and introduce solutions for them.

### SUMMARY OF THE INVENTION

[0009] According to an aspect of the invention, the invention is a hydraulically striking device comprising a cylinder body, the cylinder body forming a cylinder therein, a piston in the cylinder body, configured to move by means of a hydraulic fluid so as to reciprocate between a first and a second position in the cylinder, and a valve for controlling the movement of the piston. According to the invention, a first control channel and a second control channel extend from the valve, a first port and a second port open into the cylinder at different points in the axial direction and at a distance from one another, wherein the first port is coupled to the first control channel and the second port is coupled to the second control channel, the piston comprising at least one flow space which is arranged to be selectively coupled to the first port and to the second port and allowing the hydraulic fluid which controls the valve in the first control channel and in the second control channel to flow in one of the control channels in one direction so as to provide circulation of the hydraulic fluid controlling the valve. The flow leads in essentially one direction, for example only in one direction or sequentially in one direction.

[0010] According to another aspect of the invention, the invention is a hydraulically striking device comprising

a cylinder body, the cylinder body forming a cylinder therein, a piston in the cylinder body, configured to move by means of a hydraulic fluid so as to reciprocate between a first and a second position in the cylinder, and a valve for controlling the movement of the piston, where the valve is provided with a means for moving. According to the invention, a first control channel and a second control channel extend from the valve, a first port and a second port open into the cylinder at different points in the axial direction and at a distance from one another, wherein the first port is coupled to the first control channel and the second port is coupled to the second control channel, the piston comprising at least one flow space which is arranged to be selectively coupled to the first port and to the second port, wherein the location of one or more flow spaces in the piston allows one of the control channels to be blocked while the means for moving of the valve moves and receives or delivers hydraulic fluid.

**[0011]** In one embodiment of the invention, the cylinder body 1 is formed of one or more parts. In one embodiment of the invention, the piston comprises one flow space, which is a uniform groove between a first edge and a second edge of the flow space, wherein the edges act as closing surfaces of the flow of the hydraulic fluid. In one embodiment of the invention, the piston comprises a first portion and a second portion, wherein the flow space is located between the portions.

**[0012]** In one embodiment of the invention, the valve is provided in connection with the hydraulically striking device. In one embodiment of the invention, the piston has a first longitudinal center axis and the valve has a second longitudinal center axis, wherein the second longitudinal center axis coincides with the first longitudinal center axis. In one embodiment of the invention, the valve is provided inside the cylinder body. In one embodiment of the invention, the valve is provided outside the cylinder body. In one embodiment of the invention, the valve is for example piped, detachably or fixedly connected with fittings, connected with flexible hoses, bolted as a separate part or connected into the cylinder body as a combination of the methods described above.

**[0013]** In one embodiment of the invention, the valve comprises a means for moving which moves for a specific distance from its initial position within the valve and takes hydraulic fluid in an amount corresponding to the movement and returns hydraulic fluid when moving back to the initial position. In one embodiment of the invention, the hydraulic fluid flows into a closed space of the valve and changes the volume of fluid inside the valve by moving the means for moving. In one embodiment of the invention, the direction of movement of the piston is changed by the position of the means for moving. In one embodiment of the invention, the means for moving is a spool or a poppet or a combination of a spool and a poppet of the valve.

**[0014]** In one embodiment of the invention, the hydraulically striking device further comprises a third port, a fourth port, a pressure line and a return line, wherein the

third port and the fourth port open into the cylinder at different points in the axial direction and at a distance from one another and from the first port and the second port, the piston comprising at least one flow space which is arranged to be selectively coupled to the first port, to the second port, to the third port and to the fourth port, wherein the third port is coupled with the pressure line and the fourth port is coupled with the return line. In one embodiment of the invention, the third port is coupled with the pressure line of the hydraulically striking device so as to move the means for moving with the pressure provided by the hydraulic fluid which flows therefrom at times, and the fourth port is coupled with the return line of the hydraulically striking device into which the hydraulic fluid returned by the means for moving is allowed to flow at times as the means for moving moves back to its initial position. In one embodiment of the invention, the ports mentioned in this paragraph and above in the first and second paragraph are arranged to open towards the outer cylindrical surface of the piston. In one embodiment of the invention, the flow space mentioned in this paragraph and above in the first and second paragraph is a recess, one or more grooves, one or more drillings or one or more channels arranged in the surface of the piston. In one embodiment of the invention, these flow space embodiments provide in the selective coupling a space between the piston and the cylinder body for flowing. In one embodiment, a choke is provided in the fourth port or in the return line.

**[0015]** In one embodiment of the invention, in the selective coupling with the piston disposed in the first or second position, the piston is arranged to block the flow communication to at least one of the control channels by blocking the port connected to that control channel.

**[0016]** In one embodiment of the invention, in the first position of the piston, the flow space connects the third port to the first port and the piston blocks the second port and the fourth port, allowing the hydraulic fluid to flow via the first control channel. In one embodiment of the invention, in the second position of the piston, the piston blocks the third port and the flow space connects the first port and the second port to the fourth port, allowing the hydraulic fluid to flow from the valve via both control channels. In one embodiment of the invention, in the first and second position of the piston, the hydraulic fluid flows in the second control channel in essentially one direction.

**[0017]** In one embodiment of the invention, in the second position of the piston, the piston blocks the third port and the first port and the flow space connects the second port to the fourth port, the hydraulic fluid flowing via the second control channel. In one embodiment of the invention, in the first position of the piston, the flow space connects the third port to the first port and to the second port and the piston blocks the fourth port, allowing the hydraulic fluid to flow via both control channels. In one embodiment of the invention, in the first and second position of the piston, the hydraulic fluid flows in the first control channel in essentially one direction.

**[0018]** In one embodiment of the invention, in the first position of the piston, the flow space connects the third port to the first port and the piston blocks the second port and the fourth port, allowing the hydraulic fluid to flow via the first control channel. In one embodiment of the invention, in the second position of the piston, the piston blocks the third port and the first port and the flow space connects the second port to the fourth port, allowing the hydraulic fluid to flow from the valve via the second control channel. In one embodiment of the invention, in the first and second position of the piston, the hydraulic fluid flows in both of the control channels in essentially one direction.

**[0019]** In one embodiment of the invention, when the first control channel and the second control channel are provided in flow communication, the flow is divided among the channels.

**[0020]** In one embodiment of the invention, the first position of the piston is the front position of the piston, wherein the piston is pulled out from the cylinder body and moving towards its extreme position, and the second position of the piston is the back position of the piston, wherein the piston is retracted into the cylinder body and moving towards its extreme position. In one embodiment of the invention, the reciprocating movement of the piston is used for example for drilling rock or for example in applications where a material, for example rock, has to be put into smaller pieces. In one embodiment of the invention, the hydraulically striking device is a rock drilling machine.

**[0021]** The hydraulically striking device described here has many significant advantages comparing to the prior art. When the hydraulic fluid controlling the valve circulates, the fluid flows from the pressure line to the valve and flows back to the tank via another channel. This action is achieved by arranging the fluid flow essentially in one direction in one of the control channels when the piston reciprocates back and forth. A preferable situation is when the fluid flows in both control channels in essentially one direction when the piston moves back and forth. This enables efficient circulation, as most of the fluid flows via the means for moving, e.g. a spool, wherein the movement of the spool causes a flow in essentially one direction while the spool reciprocates.

**[0022]** Both actions flush the valve and simultaneously cool this part of the circuit. Both actions help to prevent cavitation in the system. The constantly changing fluid does not wear the structures in use so easily. The circulation prevents the possible air pockets formed during the assembly process from being trapped inside for a substantially long time. The fluid in this situation is less subject to cavitation. Most of the air is circulated out from the valve, resulting in a smaller risk of delay or malfunctioning of the valve.

**[0023]** This hydraulically striking device has a choke in the fourth port or in the return line. This feature enables preventing or alleviating cavitation even more in the circuit. The choke restricts the flow of the fluid returning to the tank and creates a back pressure that raises the pres-

sure level. The choke reduces the risk of cavitation in a substantially low pressure fluid. The embodiments of the invention described herein may be used in any combination with each other. Several or at least two of the embodiments may be combined together to form a further embodiment of the invention. A method or a device to which the invention is related may comprise at least one of the embodiments of the invention described hereinbefore.

**[0024]** It is to be understood that any of the above embodiments or modifications can be applied singly or in combination to the respective aspects to which they refer, unless they are explicitly stated as excluding alternatives.

## 5 BRIEF DESCRIPTION OF THE DRAWINGS

**[0025]** The accompanying drawings, which are included to provide a further understanding of the invention and constitute a part of this specification, illustrate embodiments of the invention and together with the description help to explain the principles of the invention. In the drawings:

**Figs. 1a - 1b** are simplified schematical illustrations of a hydraulically striking device;

**Figs. 2a - 2b** are other simplified schematical illustrations of a hydraulically striking device;

**Figs. 3a - 3b** are other simplified schematical illustrations of a hydraulically striking device;

**Figs. 4a - 4b** are illustrations of a cross-section of a simplified hydraulically striking device; and

**Figs. 5a - 5b** are simplified schematical illustrations of one example of a hydraulically striking device according to prior art.

## 40 DETAILED DESCRIPTION OF THE INVENTION

**[0026]** Reference will now be made in detail to the embodiments of the present invention, examples of which are illustrated in the accompanying drawings.

**[0027]** Figures 1 to 4 are simplified illustrations of different examples of a hydraulically striking device. Due to the simplification in figures 1a to 3b and 5a and 5b, the cylinder body 1 is only described by two straight horizontal lines, wherein the cylinder 2 is formed between the lines. Due to the simplification in figures 1a to 3b and 5a and 5b, the valve 6 is described as a small cylinder in fluid communication with the piston 3. The direction of flow in the circuit of the device is indicated with arrow (s) in figures 1a to 5b.

**[0028]** One example of the hydraulically striking device comprises a cylinder body 1, wherein the cylinder body 1 forms a cylinder 2. The cylinder body 1 comprises a piston 3 configured to move by means of a hydraulic fluid

so as to reciprocate between a first and a second position in the cylinder 2. In connection with the device there is arranged a valve 6 for controlling the movement of the piston 3. A first control channel 7 and a second control channel 8 extend from the valve 6, a first port 9 and a second port 10 open into the cylinder 2 at different points in the axial direction and at a distance from one another, wherein the first port 9 is coupled to the first control channel 7 and the second port 10 is coupled to the second control channel 8. The piston 3 is provided with at least one flow space 13 for selective coupling of the first port 9 and the second port 10, allowing the hydraulic fluid which controls the valve 6 in the first control channel 7 and in the second control channel 8 to flow in one of the control channels 7 and 8 in one direction so as to provide circulation of the hydraulic fluid controlling the valve 6. The selective coupling means that the piston 3 selects one of the ports 9, 10 in either of the positions of the piston to be connected with the flow space 13. The flow leads in essentially one direction, for example only in one direction or sequentially in one direction. The cylinder body 1 is formed of one or more parts.

**[0029]** Another example of the hydraulically striking device comprises a cylinder body 1, wherein the cylinder body 1 forms a cylinder 2. The cylinder body 1 comprises a piston 3 configured to move by means of a hydraulic fluid so as to reciprocate between a first and a second position in the cylinder 2. In connection with the hydraulically striking device there is arranged a valve 6 for controlling the movement of the piston 3, where the valve 6 is provided with a means for moving 14. A first control channel 7 and a second control channel 8 extend from the valve 6, a first port 9 and a second port 10 open into the cylinder 2 at different points in the axial direction and at a distance from one another, wherein the first port 9 is coupled to the first control channel 7 and the second port 10 is coupled to the second control channel 8. The piston 3 comprises at least one flow space 13 which is arranged to be selectively coupled to the first port 9 and to the second port 10, wherein the location of one or more flow spaces 13 in the piston 3 allows one of the control channels 8, 7 to be blocked while the means for moving 14 of the valve 6 moves and receives or delivers hydraulic fluid.

**[0030]** In these examples, the piston 3 comprises one flow space 13, which is a uniform groove between a first edge 16 and a second edge 17 of the flow space 13, wherein the edges 16, 17 act as closing surfaces of the flow of the hydraulic fluid. The piston 3 further comprises a first portion 18 and a second portion 19, wherein the flow space 13 is located between the portions 18, 19.

**[0031]** The valve 6 is provided in connection with the hydraulically striking device. The valve 6 can be arranged inside or outside the cylinder body 1. In one exemplary embodiment, the valve 6 is arranged outside the cylinder body 1. In this embodiment, the valve 6 is connected to the cylinder body 1 and into co-operation with the piston by other means, for example by connection points ar-

ranged into the cylinder body 1 for the valve 6. For example, the valve 6 may be piped, detachably or fixedly connected with fittings, connected with flexible hoses into the cylinder body 1. In one example, a hydraulic manifold is machined for the valve 6 where the valve 6 may be installed, and afterwards this manifold may be mounted with bolts into the cylinder body 1. This connection may be made in combination of the previously mentioned connections. When the valve 6 is used, it is working in the device or combined to the device, thereby being part of the device. In one example, the valve 6 is arranged inside the cylinder body 1 as described above. This decreases the number of parts needed in the device and reduces the number of potential leakage points.

**[0032]** The valve 6 comprises the means for moving 14 which moves for a specific distance from its initial position within the valve 6 and takes hydraulic fluid in an amount corresponding to the movement and returns hydraulic fluid when moving back to the initial position. The direction of movement of the piston 3 is changed by the position of the means for moving 14. In these examples, the means for moving 14 is a spool or a poppet or a combination of a spool and a poppet of the valve 6. The movement of the means for moving 14 is operated by feeding hydraulic fluid via a channel 7, 8 into the valve 6.

**[0033]** In these examples, the hydraulically striking device comprises a third port 11, a fourth port 12, a pressure line P and a return line T, wherein the third port 11 and the fourth port 12 open into the cylinder 2 at different points in the axial direction and at a distance from one another and from the first port 9 and the second port 10, the piston 3 comprising at least one flow space 13 which is arranged to be selectively coupled to the first port 9, to the second port 10, to the third port 11 and to the fourth port 12, wherein the third port 11 is coupled with the pressure line P and the fourth port 12 is coupled with the return line T. In one example, the third port 11 is coupled with the pressure line P of the hydraulically striking device so as to move the means for moving 14 with the pressure provided by the hydraulic fluid which flows therefrom at times, and the fourth port 12 is coupled with the return line T of the hydraulically striking device into which the hydraulic fluid returned by the means for moving 14 is allowed to flow at times as the means for moving 14 moves back to its initial position.

**[0034]** The pressure of the pressure line P may act on both sides of the means for moving 14. In figures 1a to 4a, the pressure of the pressure line P acts on both sides of the means for moving 14. The area of the means for moving 14 is bigger on the side where the control channels 7, 8 connect to the valve 6. This enables in figures 1a to 4a that, when the same pressure of the pressure line P acts on both sides of the means for moving 14, which is indicated in the figures 1a to 4a with the reference P on both sides of the means for moving, the force created on the side of the control channels 7, 8 is greater than on the opposite side of the means for moving 14 and the means for moving moves (left) in the direction indicated

with an arrow. Respectively, in figures 1b to 4b, when the tank line T is connected on the side of the control channels 7, 8 of the means for moving 14, the means for moving 14 moves by the pressure of the pressure line P towards (right) in the direction indicated with an arrow. One of the control channels 8, 7 is blocked while the means for moving 14 of the valve 6 moves and, depending on the needed direction of the movement of the piston 3, receives or delivers hydraulic fluid. Hydraulic fluid flows to a closed space of the valve 6 and changes the volume of the fluid inside the valve 6 by moving the means for moving 14.

**[0035]** The ports 9, 10, 11, 12 are arranged to open towards the outer cylindrical surface of the piston 3. The flow space 13 is arranged in the selective coupling between the piston 3 and the cylinder body 1. The flow space 13 may be a groove which is arranged rotationally symmetrically in the surface of the piston 3. Other arrangements to provide the flow space 13 are possible. The flow space 13 is for example a groove machined in the axial direction into the surface of the piston 3, or optionally there may be several grooves around the piston 3. In one example, the flow space 13 is formed by one or more holes drilled into the piston 3 or the flow space 13 is formed by one or more channels arranged in the surface of the piston 3. Common for all flow spaces 13 is that they provide a space between the piston 3 and the cylinder body 1 allowing the flowing of hydraulic fluid. By selective coupling, the piston 3 selects some of the ports 9, 10, 11, 12 in either of the positions of the piston to be connected with the flow space 13, while some of the ports 9, 10, 11, 12 can be blocked by the piston 3. The choke 15 is provided in the fourth port 12 or in the return line T, reducing the risk of cavitation when the fluid flows to the tank T by restricting the flow and raising the pressure level in the portion of the circuit before the choke 15.

**[0036]** In the selective coupling with the piston 3 disposed in the first or second position, the piston 3 is arranged to block the flow communication to at least one of the control channels 7, 8 by blocking the first port 9 or second port 10 connected to that control channel. When the first control channel 7 and the second control channel 8 are arranged in flow communication, the flow is divided among the channels 7, 8, for example substantially equally among the channels 7, 8.

**[0037]** In the selective coupling with the piston 3 disposed in the first or second position, the piston 3 is arranged to block the flow communication to at least one of the control channels 7, 8 by blocking the port 9, 10 connected to that control channel.

**[0038]** Figures 1a and 1b illustrate one example of a simplified hydraulically striking device, wherein Figure 1a illustrates the first position of the piston 3 and Figure 1b the second position of the piston 3. Figure 1a illustrates the first position of the piston 3, wherein the flow space 13 connects the third port 11 to the first port 9 and the piston 3 blocks the second port 10 and the fourth port

12, allowing the hydraulic fluid to flow via the first control channel 7. Figure 1b illustrates the second position of the piston 3, wherein the piston 3 blocks the third port 11 and the flow space 13 connects the first port 9 and the second port 10 to the fourth port 12, allowing the hydraulic fluid to flow from the valve 6 via both control channels 7, 8. In the first and second positions of the piston 3, the hydraulic fluid flows in the second control channel 8 in one direction.

**[0039]** Figure 2 illustrates the second example of a simplified hydraulically striking device, wherein Figure 2a illustrates the first position of the piston 3 and Figure 2b the second position of the piston 3. In the second position of the piston 3, the piston 3 blocks the third port 11 and the first port 9 and the flow space 13 connects the second port 10 to the fourth port 12, the hydraulic fluid flowing via the second control channel 8. In Figure 2a, the first position of the piston 3 is shown, wherein the flow space 13 connects the third port 11 to the first port 9 and to the second port 10 and the piston 3 blocks the fourth port 12, allowing the hydraulic fluid to flow via both control channels 7, 8. In the first and second positions of the piston 3, the hydraulic fluid flows in the first control channel 7 in one direction.

**[0040]** Figure 3 illustrates the third example of a simplified hydraulically striking device, wherein Figure 3a illustrates the first position of the piston 3 and Figure 3b illustrates the second position of the piston 3. In the first position of the piston 3, the flow space 13 connects the third port 11 to the first port 9 and the piston 3 blocks the second port 10 and the fourth port 12, allowing the hydraulic fluid to flow via the first control channel 7. In the second position of the piston 3, the piston 3 blocks the third port 11 and the first port 9 and the flow space 13 connects the second port 10 to the fourth port 12, allowing the hydraulic fluid to flow from the valve 6 via the second control channel 8. In Figures 3a and 3b in the first and second position of the piston 3, the hydraulic fluid flows in both of the control channels 7, 8 in one direction.

**[0041]** In all examples, the first position of the piston 3 is the front position of the piston 3, wherein the piston is pulled out from the cylinder body 1 in proximity to its extreme position, and the second position of the piston 3 is the back position of the piston 3, wherein the piston 3 is retracted into the cylinder body 1 in proximity to its extreme position. In proximity to the extreme position of the piston 3 means that the piston 3 is in an approximate position where the piston 3 is substantially near its extreme position but not necessarily fully retracted or pulled out and where the means for moving 14 changes its position. This position is difficult to define exactly because the piston 3 is in constant movement, but the position can be e.g. 0.1 to 30 mm apart from the extreme position. The changing of the position of the means for moving 14 of the valve 6 requires some time, and after the changing of the position of the means for moving 14, the piston 3 continues its movement because of the inertia of the piston 3. Because of this physical law, the change of loca-

tions where the means for moving 14 changes its position is not necessarily exactly to the extreme positions of the piston 3.

**[0042]** In some applications, the reciprocating movement is used for example for drilling rock or for example in applications where a material, for example rock, has to be put into smaller pieces.

**[0043]** Figures 4a and 4b illustrate a cross-section of a hydraulically striking device. Figure 4a illustrates the first position of the piston 3 and Figure 4b the second position of the piston 3. The first position of the piston 3 also means here that the piston 3 has moved outwards from the cylinder body 1 to an approximate position substantially near its extreme position. The second position also means here that the piston 3 has moved inwards to the cylinder body 1 to an approximate position substantially near its extreme position. The operation of the fluid circulation of the hydraulically striking device described in Figures 4a and 4b is similar to the operation according to Figures 1a and 1b. Figures 4a and 4b illustrate a more detailed example of a hydraulically striking device and its structures.

**[0044]** The valve 6 is arranged near the inner end 190 of the piston 3. The inner space 30 in the valve 6 can be in fluid communication with the inner end 190 of the piston 3. The piston 3 is partially inside the valve 6. As the valve 6 and the means for moving 14 have a hollow inside, the piston 3 is arranged partially inside the valve 6 and the means for moving 14. The first channel 7 and second channel 8 can be arranged axially inside the cylinder body 1 and on both sides of the piston 3. A first damper 20 is arranged on the first portion 18 of the piston 3 and a second damper 20a on the second portion 19 of the piston 3. The dampers 20, 20a of the piston 3 are arranged on the tank side and the pressure side of the piston 3. The purpose of these dampers 20, 20a is to dampen and slow down the speed of the piston 3 when it reaches the proximity of its extreme position. The surface areas of the dampers 20, 20a function as surfaces on which the slowing force of the piston acts. The surface areas of the dampers 20, 20a are angular surfaces.

**[0045]** The piston 3 has a first longitudinal center axis 23 and the valve 6 has a second longitudinal center axis 24, wherein the second longitudinal center axis 24 coincides with the first longitudinal center axis 23. This means that the piston 3 and the means for moving 14 of the valve 6 move along the same axis of movement. The valve 6 is provided inside the cylinder body 1 and is concentric with the piston 3 in Figures 4a and 4b, but as explained above, other arrangements are possible.

**[0046]** The examples described herein may be used for example in a rock drilling machine. The circulation of the hydraulic fluid controlling the valve 6 is achieved by arranging the flow so that the fluid flows in essentially one direction through one or both of the control channels 7, 8. This circulation may be effected by arranging check valves (not shown) into the cylinder body 1. The check valves limit the flow in one direction. By adding for ex-

ample two check valves (not shown) into the channels 7, 8 between the piston 3 and the valve 6, it is possible to arrange a similar circulation of fluid between the valve 6 and the piston 3. In this example, the flow enters the valve 6 via the first check valve and returns from the valve 6 via the second check valve.

**[0047]** Figures 5a and 5b illustrate one example of a simplified hydraulically striking device according to prior art. The operation of the means for moving 14 in Figures 5a and 5b is similar to the operation described above in Figures 1a to 3b. Similarly as above, the reference P represents the pressure line and the reference T the tank line. Hydraulic fluid flows to a closed space in the valve 6 and changes the volume of fluid inside the valve 6 by moving the means for moving 14. The direction of flow and the direction of the means for moving 14 are described with arrow (s) also in Figures 5a and 5b. The changeover of fluid in the valve 6 depends on the distance of the channels 7, 8 and the volume of fluid in the channels 7, 8 relative to the volume of fluid received by the valve 6. The difference between Figure 5a and 5b representing the prior art is that the fluid changes only at the beginning of the channels 7, 8. These portions of the channels 7, 8 are referenced by numbers 21 and 22. This kind of a feature is not preferred because the fluid does not circulate inside the device and can cause problems such as cavitation.

**[0048]** Figure 5a illustrates the first position of the piston 3 and Figure 5b illustrates the second position of the piston 3. In the first position of the piston 3, the flow space 13 connects the third port 11 to the first port 9 and to the second port 10 and the piston 3 blocks the fourth port 12, allowing the hydraulic fluid to flow via both of the control channels 7, 8. In the second position of the piston 3, the piston 3 blocks the third port 11 and the flow space 13 connects the first port 9 and the second port 10 to the fourth port 12, allowing the hydraulic fluid to flow from the valve 6 via both of the control channels 7, 8. As the fluid flows bi-directionally in both of the control channels 7, 8 it does not circulate and so it is not changed in the valve 6.

**[0049]** This invention is particularly useful in equipment wherein hydraulically striking devices are used in the hydraulic machines that are for example working in the rock drilling or similar applications.

**[0050]** It is obvious to a person skilled in the art that with the advancement of technology, the basic idea of the invention may be implemented in various ways. The invention and its embodiments are thus not limited to the examples described above, instead they may vary within the scope of the claims.

**[0051]** The embodiments of the invention described herein may be used in any combination with each other. Several or at least two of the embodiments may be combined together to form a further embodiment of the invention. A method or a device to which the invention is related may comprise at least one of the embodiments of the invention described hereinbefore.

**[0052]** It is to be understood that any of the above embodiments or modifications can be applied singly or in combination to the respective aspects to which they refer, unless they are explicitly stated as excluding alternatives.

## Claims

### 1. A hydraulically striking device comprising

- a cylinder body (1), the cylinder body (1) forming a cylinder (2) therein,
- a piston (3) in the cylinder body (1), configured to move by means of a hydraulic fluid so as to reciprocate between a first and a second position in the cylinder (2), and
- a valve (6) for controlling the movement of the piston (3), **characterized in that** the valve comprises
  - a means for moving (14) configured to move for a specific distance from its initial position within the valve (6) and to take hydraulic fluid in an amount corresponding to the movement and to return hydraulic fluid when moving back to the initial position,
  - a first control channel (7) and a second control channel (8) extending from a closed space of the valve (6) enabling hydraulic fluid to flow to the closed space of the valve (6) and to change the volume of the fluid inside the valve (6) by moving the means for moving (14),
  - a first port (9) and a second port (10) open into the cylinder (2) at different points in the axial direction and at a distance from one another, wherein the first port (9) is coupled to the first control channel (7) and the second port (10) is coupled to the second control channel (8), wherein the piston (3) comprises
    - at least one flow space (13) which is arranged to be selectively coupled to the first port (9) and to the second port (10) and allowing the hydraulic fluid which controls the valve (6) in the first control channel (7) and in the second control channel (8) to flow in one of the control channels (7, 8) in one direction so as to provide circulation of the hydraulic fluid controlling the valve (6).

### 2. The hydraulically striking device according to claim 1, **characterized in that** the piston (3) comprises

- one flow space (13), which is a uniform groove between a first edge (16) and a second edge (17) of the flow space (13), wherein the edges (16, 17) act as closing surfaces of the flow of the hydraulic fluid.

### 3. The hydraulically striking device according to any of the claims 1 or 2, **characterized in that** the hydraulically striking device further comprises

lically striking device further comprises

- a third port (11), a fourth port (12), a pressure line (P) and a return line (T), wherein the third port (11) and the fourth port (12) open into the cylinder (2) at different points in the axial direction and at a distance from one another and from the first port (9) and the second port (10), the piston (3) comprising at least one flow space (13) which is arranged to be selectively coupled to the first port (9), to the second port (10), to the third port (11) and to the fourth port (12), wherein the third port (11) is coupled with the pressure line (P) and the fourth port (12) is coupled with the return line (T).

### 4. The hydraulically striking device according to claim 3, **characterized in that** a choke (15) is provided in the fourth port (12) or in the return line (T).

### 5. The hydraulically striking device according to any of the claims 3 or 4, **characterized in that** the direction of movement of the piston (3) is changed by the position of the means for moving (14) .

### 6. The hydraulically striking device according to any of the claims 3 to 5, **characterized in that** the means for moving (14) is a spool or a poppet or a combination of a spool and a poppet of the valve (6).

### 7. The hydraulically striking device according to any of the claims 1 to 6, **characterized in that** in the selective coupling with the piston (3) disposed in the first or in the second position, the piston (3) is arranged to block the flow communication to at least one of the control channels (7, 8) by blocking the port (9, 10) connected to that control channel.

### 8. The hydraulically striking device according to any of the claims 1 to 7, **characterized in that** in the first position of the piston (3), the flow space (13) connects the third port (11) to the first port (9) and the piston (3) blocks the second port (10) and the fourth port (12), allowing the hydraulic fluid to flow via the first control channel (7).

### 9. The hydraulically striking device according to claim 8, **characterized in that** in the second position of the piston (3), the piston (3) blocks the third port (11) and the flow space (13) connects the first port (9) and the second port (10) to the fourth port (12), allowing the hydraulic fluid to flow from the valve (6) via both control channels (7, 8).

### 10. The hydraulically striking device according to any of the claims 1 to 7, **characterized in that** in the second position of the piston (3), the piston (3) blocks the third port (11) and the first port (9) and the flow space

(13) connects the second port (10) to the fourth port (12), the hydraulic fluid flowing via the second control channel (8).

11. The hydraulically striking device according to claim 10, **characterized in that** in the first position of the piston (3), the flow space (13) connects the third port (11) to the first port (9) and to the second port (10) and the piston (3) blocks the fourth port (12), allowing the hydraulic fluid to flow via both control channels (7, 8). 5
12. The hydraulically striking device according to any of the claims 1 to 7, **characterized in that** in the first position of the piston (3), the flow space (13) connects the third port (11) to the first port (9) and the piston (3) blocks the second port (10) and the fourth port (12), allowing the hydraulic fluid to flow via the first control channel (7). 10
13. The hydraulically striking device according to claim 12, **characterized in that** in the second position of the piston (3), the piston (3) blocks the third port (11) and the first port (9) and the flow space (13) connects the second port (10) to the fourth port (12), allowing the hydraulic fluid to flow from the valve (6) via the second control channel (8). 15
14. The hydraulically striking device according to any of the claims 1 to 13, **characterized in that** when the first control channel (7) and the second control channel (8) are provided in flow communication, the flow is divided among the channels (7, 8). 20
15. The hydraulically striking device according to any of the claims 1 to 14, **characterized in that** the piston (3) has a first longitudinal center axis (23) and the valve (6) has a second longitudinal center axis (24), wherein the second longitudinal center axis (24) coincides with the first longitudinal center axis (23). 25
16. The hydraulically striking device according to any of the claims 1 to 15, **characterized in that** the hydraulically striking device is a rock drilling machine. 30
17. The hydraulically striking device according to any of the claims 1 to 16, **characterized in that** when the means for moving (14) reciprocates, the means for moving (14) is configured to receive the hydraulic fluid from at least one control channel (7, 8) into the closed space and to return the hydraulic fluid from the closed space to at least one control channel (7, 8) in such a way that oil flow is divided differently amongst the channels when the piston is in the first position and when the piston is in the second position. 35

## Patentansprüche

### 1. Ein hydraulischer Schlaghammer umfassend

- Ein Zylinderkörper (1), der Zylinderkörper (1) darin einen Zylinder (2) formend,
- Ein Kolben (3) in dem Zylinderkörper (1), der konfiguriert ist, sich mittels einer hydraulischen Flüssigkeit zu bewegen, um zwischen einer ersten und einer zweiten Position im Zylinder (2) zu pendeln, und
- Ein Ventil (6) zum Steuern der Bewegung des Kolbens (3), **dadurch gekennzeichnet, dass** das Ventil umfasst
- Eine Bewegungsvorrichtung (14), die konfiguriert ist, sich um eine bestimmte Entfernung von ihrer Ausgangsposition innerhalb des Ventils (6) zu bewegen und eine Menge der hydraulischen Flüssigkeit entsprechend der Bewegung zu nehmen und hydraulische Flüssigkeit zurückzubringen, wenn sie zur Ausgangsposition zurückkehrt,
- Ein erster Steuerungskanal (7) und ein zweiter Steuerungskanal (8), die sich von einem geschlossenen Raum des Ventils (6) austrecken, um hydraulischer Flüssigkeit zu ermöglichen, zum geschlossenen Raum des Ventils (6) zu fließen und das Volumen der Flüssigkeit im Innern des Ventils (6) durch Bewegen der Bewegungsvorrichtung (14) zu ändern,
- Ein erster Anschluss (9) und ein zweiter Anschluss (10), die in den Zylinder (2) an verschiedenen Stellen in der axialen Richtung und bei einer Entfernung voneinander geöffnet sind, wobei der erste Anschluss (9) mit dem ersten Steuerungskanal (7) verbunden ist und der zweite Anschluss (10) mit dem zweiten Steuerungskanal (8) verbunden ist, wobei der Kolben (3) umfasst
- Mindestens ein Strömungsraum (13), der angeordnet ist, ausschließlich mit dem ersten Anschluss (9) und mit dem zweiten Anschluss (10) verbunden zu sein und der die hydraulische Flüssigkeit, die das Ventil (6) im ersten Steuerungskanal (7) und im zweiten Steuerungskanal (8) steuert, in einen der Steuerungskanäle (7, 8) in eine Richtung fließen lässt, sodass eine Zirkulation der hydraulischen Flüssigkeit, die das Ventil (6) steuert, bereitgestellt wird.

### 2. Der hydraulische Schlaghammer nach Anspruch 1, **dadurch gekennzeichnet, dass** der Kolben (3) umfasst

- Ein Strömungsraum (13), der eine einheitliche Nut zwischen einer ersten Kante (16) und einer zweiten Kante (17) des Strömungsraumes (13) ist, wobei die Kanten (16, 17) als Verschlussflä-

chen der Strömung der hydraulischen Flüssigkeit fungieren.

3. Der hydraulische Schlaghammer nach irgendeinem der Ansprüche 1 oder 2, **dadurch gekennzeichnet, dass** der hydraulische Schlaghammer zudem umfasst

- Ein dritter Anschluss (11), ein vierter Anschluss (12), eine Druckleitung (P) und eine Rücklaufleitung (T), wobei sich der dritte Anschluss (11) und der vierte Anschluss (12) in den Zylinder (2) an verschiedenen Stellen in der axialen Richtung und bei einer Entfernung voneinander und vom ersten Anschluss (9) und dem zweiten Anschluss (10) öffnen, der Kolben (3) mindestens einen Strömungsraum (13) umfassend, der angeordnet ist, ausschließlich mit dem ersten Anschluss (9), mit dem zweiten Anschluss (10), mit dem dritten Anschluss (11) und mit dem vierten Anschluss (12) verbunden zu sein, wobei der dritte Anschluss (11) mit der Druckleitung (P) verbunden ist und der vierte Anschluss (12) mit der Rücklaufleitung (T) verbunden ist.

4. Der hydraulische Schlaghammer nach Anspruch 3, **dadurch gekennzeichnet, dass** eine Drossel (15) im vierten Anschluss (12) oder in der Rücklaufleitung (T) bereitgestellt wird.
5. Der hydraulische Schlaghammer nach irgendeinem der Ansprüche 3 oder 4, **dadurch gekennzeichnet, dass** die Richtung der Bewegung des Kolbens (3) durch die Position der Bewegungsvorrichtung (14) geändert wird.
6. Der hydraulische Schlaghammer nach irgendeinem der Ansprüche 3 bis 5, **dadurch gekennzeichnet, dass** die Bewegungsvorrichtung (14) eine Spule oder ein Teller oder eine Kombination aus einer Spule und einem Teller des Ventils (6) ist.
7. Der hydraulische Schlaghammer nach irgendeinem der Ansprüche 1 bis 6, **dadurch gekennzeichnet, dass**, wenn die ausschließliche Verbindung mit dem Kolben (3) in der ersten oder in der zweiten Position angeordnet ist, der Kolben (3) so angeordnet ist, die Strömungsverbindung zu mindestens einem der Steuerungskanäle (7, 8) durch Blockieren des Anschlusses (9, 10), der mit diesem Steuerungskanal verbunden ist, zu blockieren.
8. Der hydraulische Schlaghammer nach irgendeinem der Ansprüche 1 bis 7, **dadurch gekennzeichnet, dass** in der ersten Position des Kolbens (3), der Strömungsraum (13) den dritten Anschluss (11) mit dem ersten Anschluss (9) verbindet und der Kolben (3) den zweiten Anschluss (10) und den vierten An-

schluss (12) blockiert, um die hydraulische Flüssigkeit durch den ersten Steuerungskanal (7) fließen zu lassen.

- 5 9. Der hydraulische Schlaghammer nach Anspruch 8, **dadurch gekennzeichnet, dass** in der zweiten Position des Kolbens (3), der Kolben (3) den dritten Anschluss (11) blockiert und der Strömungsraum (13) den ersten Anschluss (9) und den zweiten Anschluss (10) mit dem vierten Anschluss (12) verbindet, um die hydraulische Flüssigkeit vom Ventil (6) durch beide Steuerungskanäle (7, 8) fließen zu lassen.
- 10 10. Der hydraulische Schlaghammer nach irgendeinem der Ansprüche 1 bis 7, **dadurch gekennzeichnet, dass** in der zweiten Position des Kolbens (3), der Kolben (3) den dritten Anschluss (11) blockiert und der ersten Anschluss (9) und der Strömungsraum (13) den zweiten Anschluss (10) mit dem vierten Anschluss (12) verbindet, wodurch die hydraulische Flüssigkeit durch den zweiten Steuerungskanal (8) fließt.
- 15 11. Der hydraulische Schlaghammer nach Anspruch 10, **dadurch gekennzeichnet, dass** in der ersten Position des Kolbens (3), der Strömungsraum (13) den dritten Anschluss (11) mit dem ersten Anschluss (9) und mit dem zweiten Anschluss (10) verbindet und der Kolben (3) den vierten Anschluss (12) blockiert, um die hydraulische Flüssigkeit durch beide Steuerungskanäle (7, 8) fließen zu lassen.
- 20 30 12. Der hydraulische Schlaghammer nach irgendeinem der Ansprüche 1 bis 7, **dadurch gekennzeichnet, dass** in der ersten Position des Kolbens (3), der Strömungsraum (13) den dritten Anschluss (11) mit dem ersten Anschluss (9) verbindet und der Kolben (3) den zweiten Anschluss (10) und den vierten Anschluss (12) blockiert, um die hydraulische Flüssigkeit durch den ersten Steuerungskanal (7) fließen zu lassen.
- 35 40 13. Der hydraulische Schlaghammer nach Anspruch 12, **dadurch gekennzeichnet, dass** in der zweiten Position des Kolbens (3), der Kolben (3) den dritten Anschluss (11) und den ersten Anschluss (9) blockiert und der Strömungsraum (13) den zweiten Anschluss (10) mit dem vierten Anschluss (12) verbindet, um die hydraulische Flüssigkeit vom Ventil (6) durch den zweiten Steuerungskanal (8) fließen zu lassen.
- 45 50 14. Der hydraulische Schlaghammer nach irgendeinem der Ansprüche 1 bis 13, **dadurch gekennzeichnet, dass** wenn der erste Steuerungskanal (7) und der zweite Steuerungskanal (8) in Strömungsverbindung bereitgestellt werden, die Strömung zwischen

den Kanälen (7, 8) aufgeteilt wird.

15. Der hydraulische Schlaghammer nach irgendeinem der Ansprüche 1 bis 14, **dadurch gekennzeichnet, dass** der Kolben (3) eine erste longitudinale Mittelachse (23) aufweist und das Ventil (6) eine zweite longitudinale Mittelachse (24) aufweist, wobei die zweite longitudinale Mittelachse (24) mit der ersten longitudinalen Mittelachse (23) übereinstimmt.
16. Der hydraulische Schlaghammer nach irgendeinem der Ansprüche 1 bis 15, **dadurch gekennzeichnet, dass** der hydraulische Schlaghammer eine Ge- steinsbohrmaschine ist.
17. Der hydraulische Schlaghammer nach irgendeinem der Ansprüche 1 bis 16, **dadurch gekennzeichnet, dass** wenn die Bewegungsvorrichtung (14) pendelt, die Bewegungsvorrichtung (14) so konfiguriert ist, die hydraulische Flüssigkeit von mindestens einem Steuerungskanal (7, 8) in den geschlossenen Raum aufzunehmen und die hydraulische Flüssigkeit aus dem geschlossenen Raum an mindestens einen Steuerungskanal (7, 8) auf so eine Weise zurückzu- geben, dass die Ölströmung unterschiedlich zwi- schen den Kanälen aufgeteilt ist, wenn der Kolben in der ersten Position und wenn der Kolben in der zweiten Position ist.

## Revendications

### 1. Dispositif à percussion hydraulique comprenant

- un corps de cylindre (1), le corps de cylindre (1) formant un cylindre (2) à l'intérieur de celui-ci,
- un piston (3) dans le corps de cylindre configuré pour se déplacer au moyen d'un fluide hydraulique de manière à se déplacer en va-et-vient entre des première et seconde positions dans le cylindre (2), et
- une soupape (6) pour commander le mouve- ment du piston (3), **caractérisé en ce que** la soupape comprend

- un moyen pour le déplacement (14) con- figuré pour se déplacer d'une distance spé- cifique de sa position initiale à l'intérieur de la soupape (6) et pour prendre un fluide hy- draulique en une quantité correspondant au mouvement et pour renvoyer un fluide hy- draulique en retournant à la position initiale,
- un premier canal de commande (7) et un second canal de commande (8) s'étendant d'un espace clos de la soupape (6) permet- tant à un fluide hydraulique de s'écouler vers l'espace clos de la soupape (6) et pour modifier le volume du fluide à l'intérieur de

la soupape (6) en déplaçant le moyen pour le déplacement (14),

-- un premier orifice (9) et un deuxième ori- fice (10) débouchent sur le cylindre (2) en des points différents dans la direction axiale et à une distance l'un de l'autre, dans lequel le premier orifice (9) est couplé au premier canal de commande (7) et le deuxième ori- fice (10) est couplé au second canal de commande (8), dans lequel le piston (3) comprend

-- au moins un espace d'écoulement (13) qui est agencé pour être couplé sélective- ment au premier orifice (9) et au deuxième orifice (10) et permettant au fluide hydrau- lique qui commande la soupape (6) dans le premier canal de commande (7) et dans le second canal de commande (8) de s'écou- ler dans l'un des canaux de commande (7, 8) dans une direction de manière à fournir une circulation du fluide hydraulique com- mandant la soupape (6).

### 2. Dispositif à percussion hydraulique selon la reven- dication 1, **caractérisé en ce que** le piston (3) comprend

- un espace d'écoulement (13), qui est une rai- nure uniforme entre un premier bord (16) et un second bord (17) de l'espace d'écoulement (13), dans lequel les bords (16, 17) agissent en tant que surfaces de fermeture de l'écoulement du fluide hydraulique.

### 3. Dispositif à percussion hydraulique selon l'une quel- conque des revendications 1 ou 2, **caractérisé en ce que** le dispositif à percussion hydraulique comprend en outre

- un troisième orifice (11), un quatrième orifice (12), une conduite de refoulement (P) et une conduite de retour (T), dans lequel le troisième orifice (11) et le quatrième orifice (12) débou- chent sur le cylindre (2) en des points différents dans la direction axiale et à une distance l'un de l'autre et à partir du premier orifice (9) et du deuxième orifice (10), le piston (3) comprenant au moins un espace d'écoulement (13) qui est agencé pour être couplé sélectivement au pre- mier orifice (9), au deuxième orifice (10), au troi- sième orifice (11) et au quatrième orifice (12), dans lequel le troisième orifice (11) est couplé à la conduite de refoulement (P) et le quatrième orifice (12) est couplé à la conduite de retour (T).

### 4. Dispositif à percussion hydraulique selon la reven- dication 3, **caractérisé en ce qu'**un étranglement (15) est fourni dans le quatrième orifice (12) ou dans

- la conduite de retour (T).
5. Dispositif à percussion hydraulique selon l'une quelconque des revendications 3 ou 4, **caractérisé en ce que** la direction du mouvement du piston (3) est modifiée par la position du moyen pour le déplacement (14). 5
  6. Dispositif à percussion hydraulique selon l'une quelconque des revendications 3 à 5, **caractérisé en ce que** le moyen pour le déplacement (14) est un tiroir ou un champignon ou une combinaison d'un tiroir et d'un champignon de la soupape (6). 10
  7. Dispositif à percussion hydraulique selon l'une quelconque des revendications 1 à 6, **caractérisé en ce que** dans le couplage sélectif avec le piston (3) disposé dans les première ou seconde positions, le piston (3) est agencé pour bloquer la communication d'écoulement vers au moins l'un des canaux de commande (7, 8) en bloquant l'orifice (9, 10) relié à ce canal de commande. 15
  8. Dispositif à percussion hydraulique selon l'une quelconque des revendications 1 à 7, **caractérisé en ce que** dans la première position du piston (3), l'espace d'écoulement (13) relie le troisième orifice (11) au premier orifice (9) et le piston (3) bloque le deuxième orifice (10) et le quatrième orifice (12), permettant au fluide hydraulique de s'écouler par l'intermédiaire du premier canal de commande (7). 20
  9. Dispositif à percussion hydraulique selon la revendication 8, **caractérisé en ce que** dans la seconde position du piston (3), le piston (3) bloque le troisième orifice (11) et l'espace d'écoulement (13) relie le premier orifice (9) et le deuxième orifice (10) au quatrième orifice (12), permettant au fluide hydraulique de s'écouler depuis la soupape (6) par l'intermédiaire des deux canaux de commande (7, 8). 25
  10. Dispositif à percussion hydraulique selon l'une quelconque des revendications 1 à 7, **caractérisé en ce que** dans la seconde position du piston (3), le piston (3) bloque le troisième orifice (11) et le premier orifice (9) et l'espace d'écoulement (13) relie le deuxième orifice (10) au quatrième orifice (12), le fluide hydraulique s'écoulant par l'intermédiaire du second canal de commande (8). 30
  11. Dispositif à percussion hydraulique selon la revendication 10, **caractérisé en ce que** dans la première position du piston (3), l'espace d'écoulement (13) relie le troisième orifice (11) au premier orifice (9) et au deuxième orifice (10) et le piston (3) bloque le quatrième orifice (12), permettant au fluide hydraulique de s'écouler par l'intermédiaire des deux canaux de commande (7, 8). 35
  12. Dispositif à percussion hydraulique selon l'une quelconque des revendications 1 à 7, **caractérisé en ce que** dans la première position du piston (3), l'espace d'écoulement (13) relie le troisième orifice (11) au premier orifice (9) et le piston (3) bloque le deuxième orifice (10) et le quatrième orifice (12), permettant au fluide hydraulique de s'écouler par l'intermédiaire du premier canal de commande (7). 40
  13. Dispositif à percussion hydraulique selon la revendication 12, **caractérisé en ce que** dans la seconde position du piston (3), le piston (3) bloque le troisième orifice (11) et le premier orifice (9) et l'espace d'écoulement (13) relie le deuxième orifice (10) au quatrième orifice (12) permettant au fluide hydraulique de s'écouler depuis la soupape (6) par l'intermédiaire du second canal de commande (8). 45
  14. Dispositif à percussion hydraulique selon l'une quelconque des revendications 1 à 13, **caractérisé en ce que** lorsque le premier canal de commande (7) et le second canal de commande (8) sont fournis en communication d'écoulement, l'écoulement est divisé parmi les canaux (7, 8). 50
  15. Dispositif à percussion hydraulique selon l'une quelconque des revendications 1 à 14, **caractérisé en ce que** le piston (3) présente un premier axe central longitudinal (23) et la soupape (6) présente un second axe central longitudinal (24), dans lequel le second axe central longitudinal (24) coïncide avec le premier axe central longitudinal (23). 55
  16. Dispositif à percussion hydraulique selon l'une quelconque des revendications 1 à 15, **caractérisé en ce que** le dispositif à percussion hydraulique est une perforatrice de roches.
  17. Dispositif à percussion hydraulique selon l'une quelconque des revendications 1 à 16, **caractérisé en ce que** lorsque le moyen pour le déplacement (14) se déplace en va-et-vient, le moyen pour le déplacement (14) est configuré pour recevoir le fluide hydraulique d'au moins un canal de commande (7, 8) à l'espace clos et pour renvoyer le fluide hydraulique de l'espace clos à au moins un canal de commande (7, 8) de sorte qu'un écoulement d'huile soit divisé différemment parmi les canaux lorsque le piston est dans la première position et lorsque le piston est dans la seconde position.

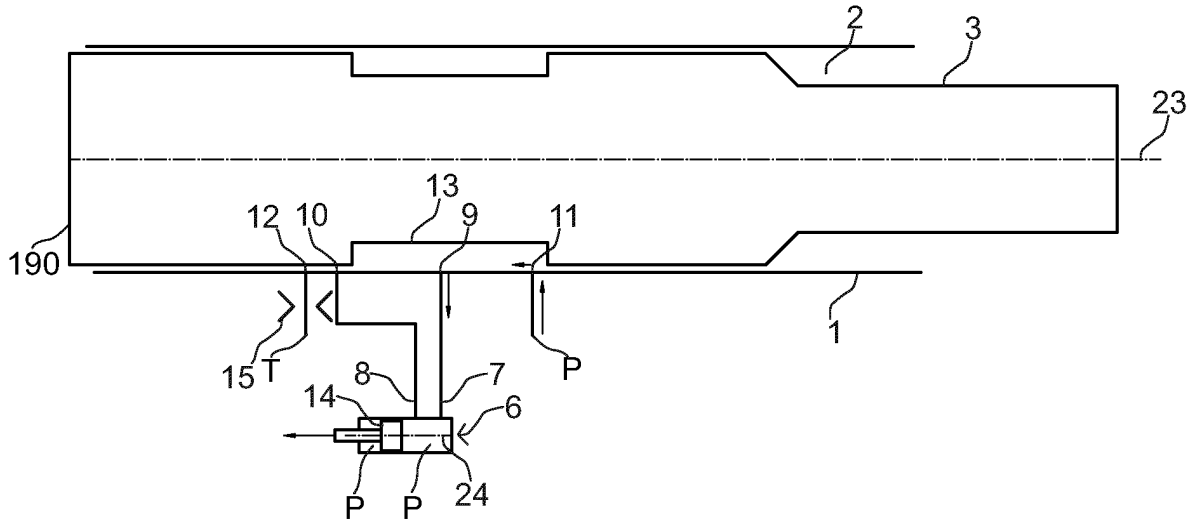

FIG. 1a

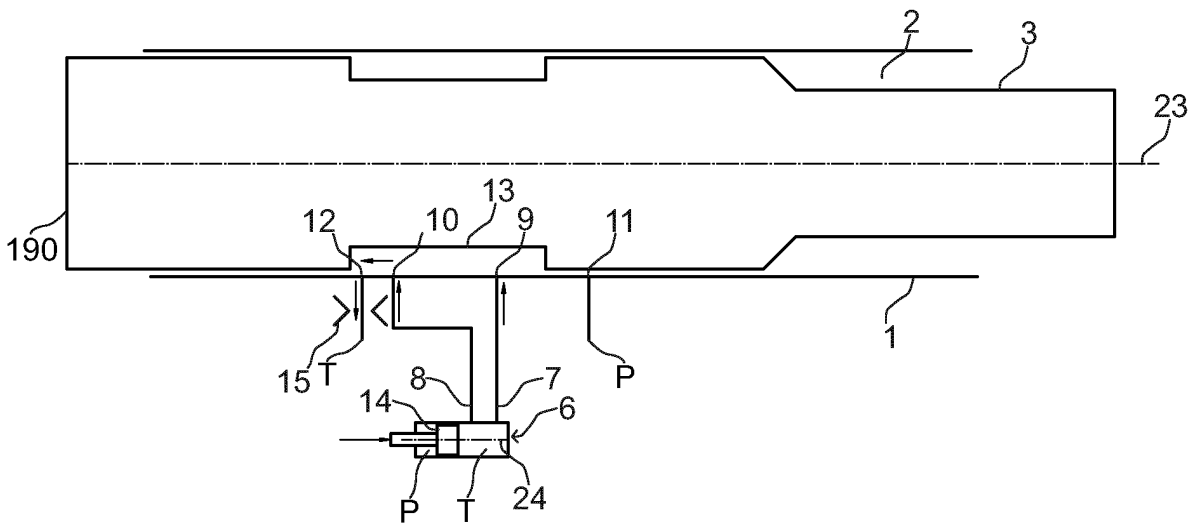

FIG. 1b

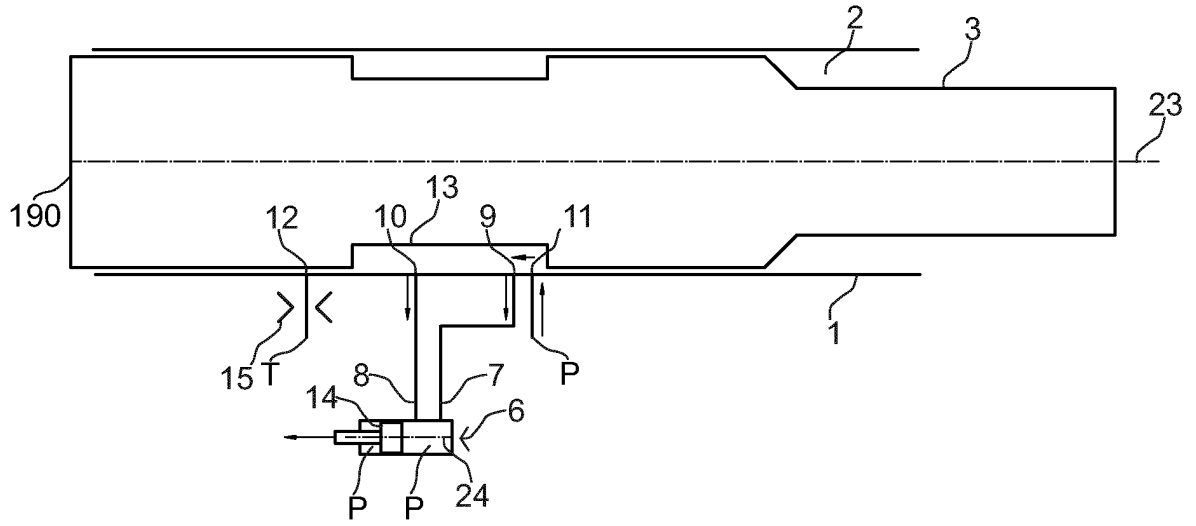

FIG. 2a

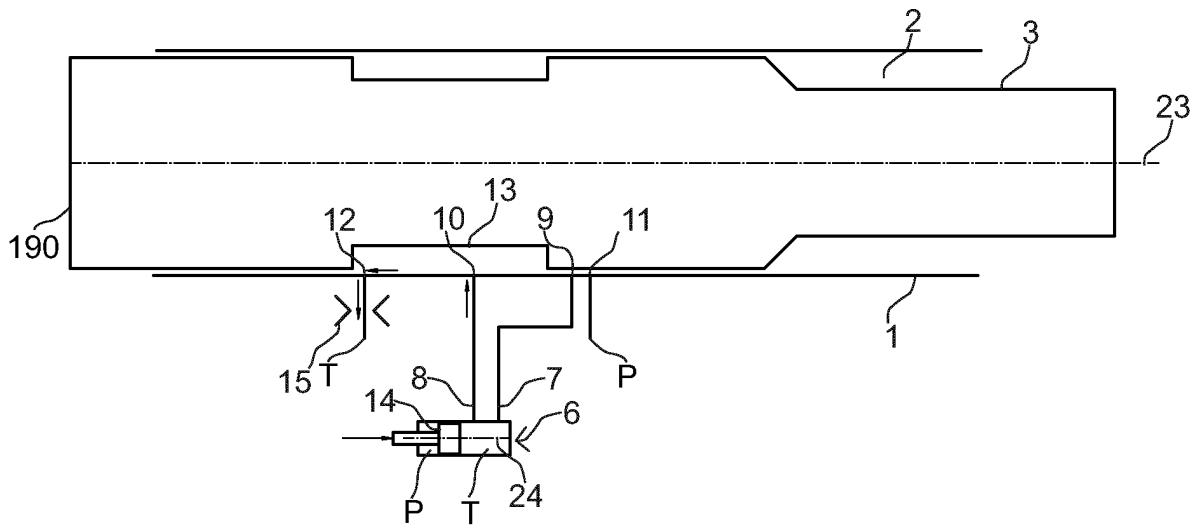

FIG. 2b

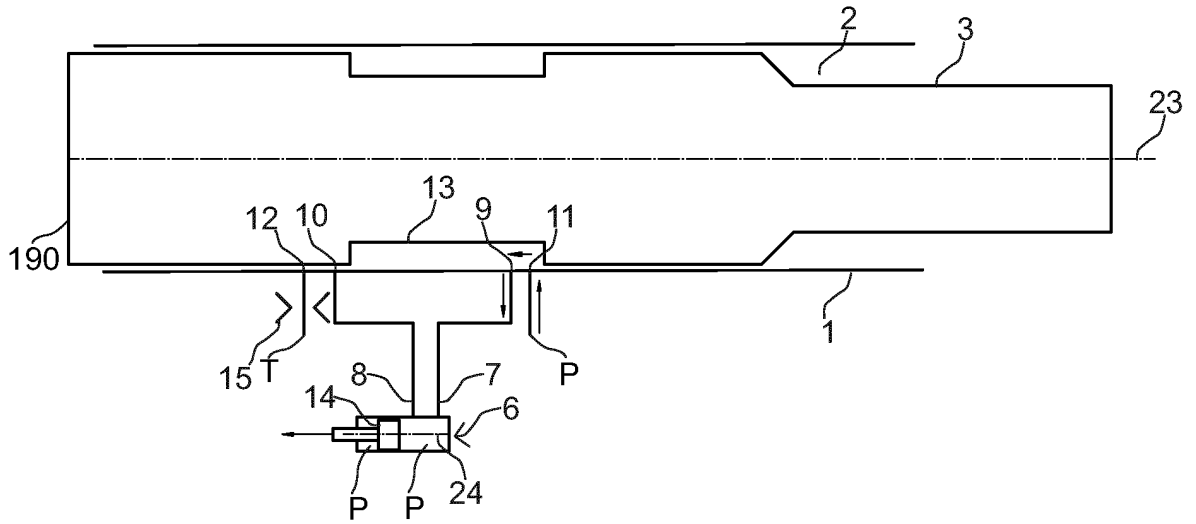

FIG. 3a

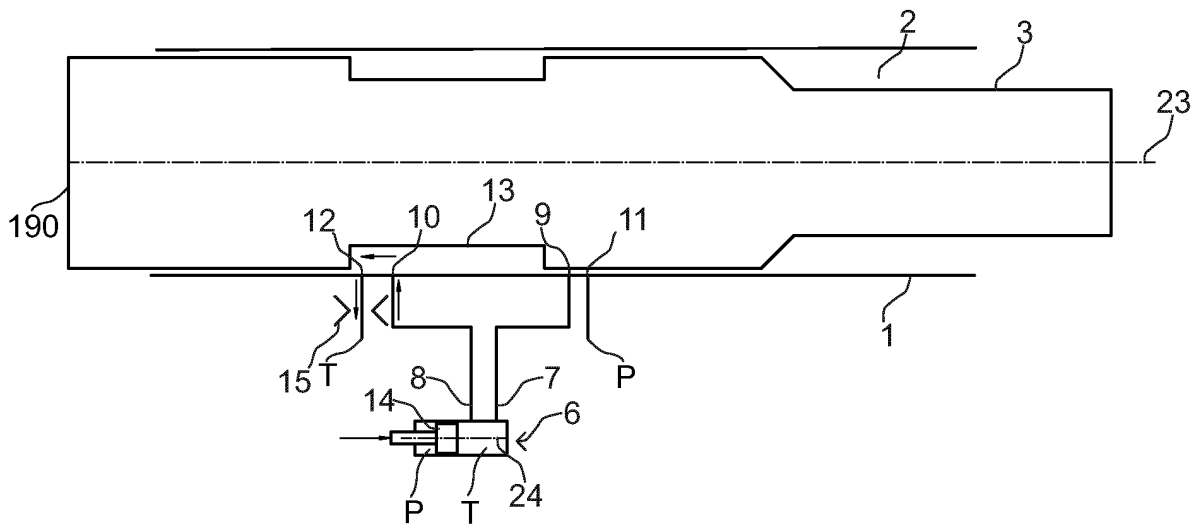

FIG. 3b

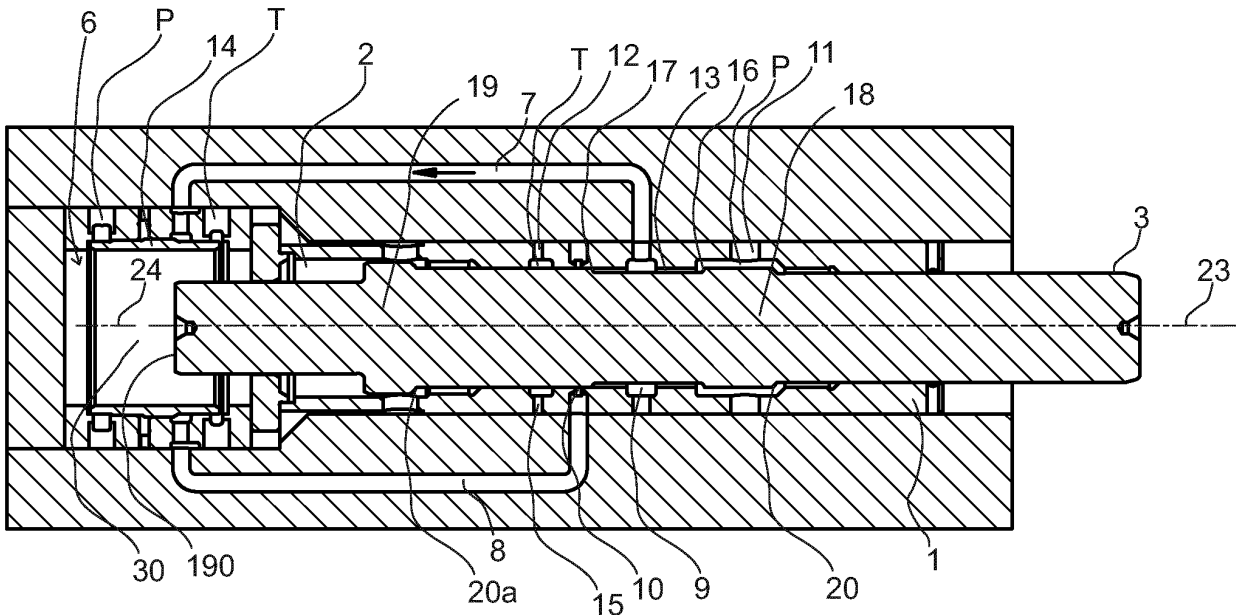

FIG. 4a

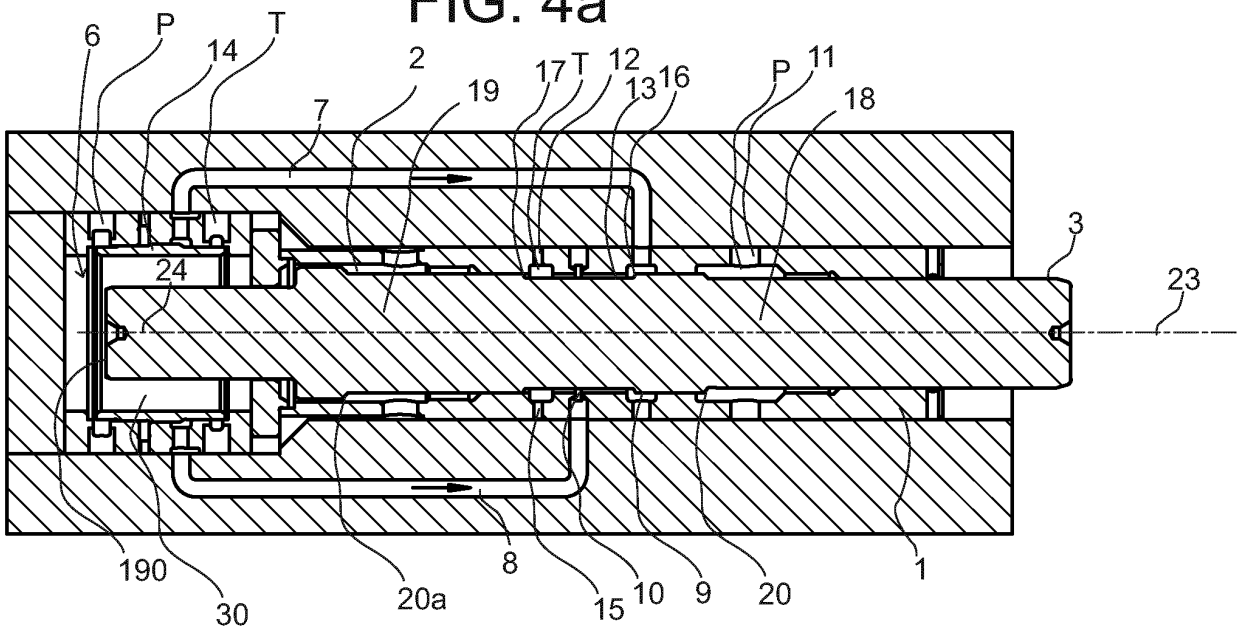

FIG. 4b

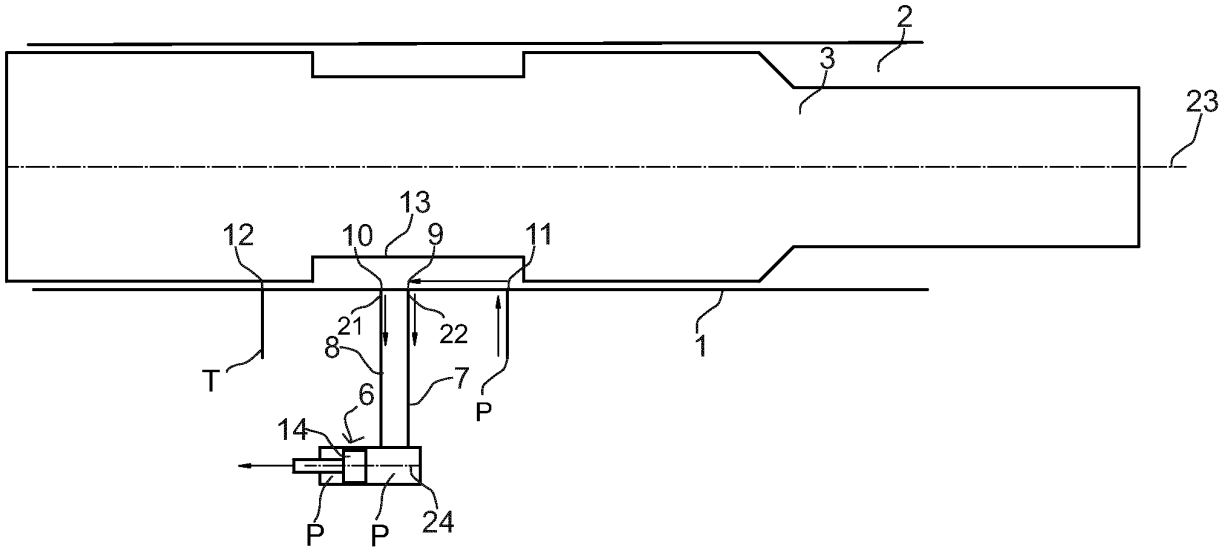

FIG. 5a

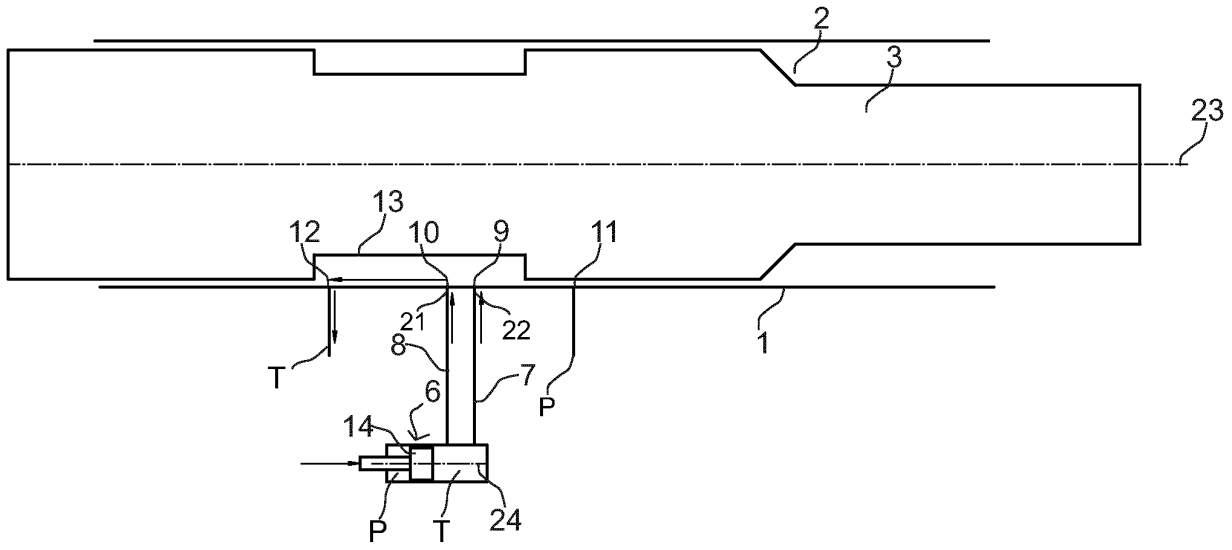

FIG. 5b

**REFERENCES CITED IN THE DESCRIPTION**

*This list of references cited by the applicant is for the reader's convenience only. It does not form part of the European patent document. Even though great care has been taken in compiling the references, errors or omissions cannot be excluded and the EPO disclaims all liability in this regard.*

**Patent documents cited in the description**

- US 5715897 A [0007]