



## INTERNATIONAL APPLICATION PUBLISHED UNDER THE PATENT COOPERATION TREATY (PCT)

<p>(51) International Patent Classification<sup>6</sup> : <b>D06Q</b></p>	<p><b>A2</b></p>	<p>(11) International Publication Number: <b>WO 96/18768</b></p> <p>(43) International Publication Date: 20 June 1996 (20.06.96)</p>
<p>(21) International Application Number: PCT/IB95/01170</p> <p>(22) International Filing Date: 8 December 1995 (08.12.95)</p> <p>(30) Priority Data: 08/352,376 8 December 1994 (08.12.94) US</p> <p>(71) Applicant: RONAI, Monica [BR/BR]; Apartamento 204, Rua General Glicereo, 224, Rio de Janeiro (BR).</p> <p>(72) Inventor: RONAI, Anton; 231-174 Street #818, North Miami Beach, FL 33160 (US).</p>		<p>(81) Designated States: AM, AT, AU, BB, BG, BR, BY, CA, CH, CN, CZ, DE, DK, EE, ES, FI, GB, GE, HU, IS, JP, KE, KG, KP, KR, KZ, LK, LR, LT, LU, LV, MD, MG, MN, MW, MX, NO, NZ, PL, PT, RO, RU, SD, SE, SG, SI, SK, TJ, TM, TT, UA, UG, UZ, VN, European patent (AT, BE, CH, DE, DK, ES, FR, GB, GR, IE, IT, LU, MC, NL, PT, SE), OAPI patent (BF, BJ, CF, CG, CI, CM, GA, GN, ML, MR, NE, SN, TD, TG), ARIPO patent (KE, LS, MW, SD, SZ, UG).</p> <p><b>Published</b> <i>Without international search report and to be republished upon receipt of that report.</i></p>
<p>(54) Title: A TEXTILE MANUFACTURING APPARATUS AND METHOD</p>		
<p>(57) Abstract</p> <p>A textile manufacturing apparatus to be used to manufacture a sequined textured fabric including a first and a second material film, portions of the second material film protruding through the first material film, the manufacturing apparatus being structured to cut an array of geometric shapes into a dual layer sheet formed by the first and second material films. The geometric shaped cutouts define a plurality of geometrically shaped members and a plurality of geometrically shaped apertures. Further, the manufacturing apparatus is structured to push the geometrically shaped members into a raised orientation above an upper surface of the dual layer sheet, the geometrically shaped members of the second material film protruding through the geometrically shaped apertures of the first material film. The apparatus is further structured to stagger the first material film relative to the second material film so as to space the geometrically shaped members of each material film from one another in order to form the sequined, textured fabric. Finally, a backing material layer is added to secure the first and second material films in their staggered orientation. The step ensures that the overall attractive appearance of the fabric (11) is maintained and that the fabric (11) will not easily tear or unravel during use.</p>		

**FOR THE PURPOSES OF INFORMATION ONLY**

Codes used to identify States party to the PCT on the front pages of pamphlets publishing international applications under the PCT.

<b>AT</b>	Austria	<b>GB</b>	United Kingdom	<b>MR</b>	Mauritania
<b>AU</b>	Australia	<b>GE</b>	Georgia	<b>MW</b>	Malawi
<b>BB</b>	Barbados	<b>GN</b>	Guinea	<b>NE</b>	Niger
<b>BE</b>	Belgium	<b>GR</b>	Greece	<b>NL</b>	Netherlands
<b>BF</b>	Burkina Faso	<b>HU</b>	Hungary	<b>NO</b>	Norway
<b>BG</b>	Bulgaria	<b>IE</b>	Ireland	<b>NZ</b>	New Zealand
<b>BJ</b>	Benin	<b>IT</b>	Italy	<b>PL</b>	Poland
<b>BR</b>	Brazil	<b>JP</b>	Japan	<b>PT</b>	Portugal
<b>BY</b>	Belarus	<b>KE</b>	Kenya	<b>RO</b>	Romania
<b>CA</b>	Canada	<b>KG</b>	Kyrgystan	<b>RU</b>	Russian Federation
<b>CF</b>	Central African Republic	<b>KP</b>	Democratic People's Republic of Korea	<b>SD</b>	Sudan
<b>CG</b>	Congo	<b>KR</b>	Republic of Korea	<b>SE</b>	Sweden
<b>CH</b>	Switzerland	<b>KZ</b>	Kazakhstan	<b>SI</b>	Slovenia
<b>CI</b>	Côte d'Ivoire	<b>LI</b>	Liechtenstein	<b>SK</b>	Slovakia
<b>CM</b>	Cameroon	<b>LK</b>	Sri Lanka	<b>SN</b>	Senegal
<b>CN</b>	China	<b>LU</b>	Luxembourg	<b>TD</b>	Chad
<b>CS</b>	Czechoslovakia	<b>LV</b>	Latvia	<b>TG</b>	Togo
<b>CZ</b>	Czech Republic	<b>MC</b>	Monaco	<b>TJ</b>	Tajikistan
<b>DE</b>	Germany	<b>MD</b>	Republic of Moldova	<b>TT</b>	Trinidad and Tobago
<b>DK</b>	Denmark	<b>MG</b>	Madagascar	<b>UA</b>	Ukraine
<b>ES</b>	Spain	<b>ML</b>	Mali	<b>US</b>	United States of America
<b>FI</b>	Finland	<b>MN</b>	Mongolia	<b>UZ</b>	Uzbekistan
<b>FR</b>	France			<b>VN</b>	Viet Nam
<b>GA</b>	Gabon				

DescriptionA TEXTILE MANUFACTURING APPARATUS AND METHODBACKGROUND OF THE INVENTION

5

Field of the Invention

The present invention relates to a textile manufacturing apparatus utilized to manufacture a sequined, textured fabric having an attractive and uniform exterior appearance and being substantially secure in its construction, in a substantially rapid and cost-effective manner.

Description of the Related Art

When manufacturing a sequined fabric, the intricate manufacturing required can often be quite difficult and time-consuming, thereby making the fabric quite expensive. Specifically, the attractive nature of sequined fabrics is primarily due to the three-dimensional appearance of the various sequined elements disposed along the fabric's surface. With most such fabrics, each individual sequined element must be directly secured to an underlying fabric, a process that can be quite difficult given the number of sequins implemented in substantially close proximity from one another. Also, in manufacturing similar types of fabrics such as that disclosed in the patent to Giannone, Sr. (U.S. Patent No. 3,650,881), reflective material films are utilized to provide the sequining effect. These existing textiles, however, can be quite limited in their functionality, primarily due to the ease in which they become unraveled or separated, and furthermore, are quite difficult to construct. In fact, conventional methods of constructing such fabrics incorporate manual inlaying of various material layers, a process that can be quite expensive due to its labor intensive requirements.

Accordingly, there is a substantial need for an improved sequined, textured fabric, which can be effectively utilized in a multitude of differing applications, and an apparatus and method which can make such a fabric in a rapid and cost-effective manner. The apparatus and method of the present invention are designed specifically to provide quantities of an attractive and highly usable sequined, texture fabric at increased speeds and reduced

costs than was previously possible for the production of sequined fabrics.

### Summary of the Invention

5           The present invention relates to a textile manufacturing apparatus which will be utilized to manufacture a sequined, textured fabric of the type which includes first and second material films, portions of the second material film protruding through the first material film to achieve the attractive sequined,  
10 textured appearance.

          Included as part of the textile manufacturing apparatus are cutting means. Specifically, the cutting means are structured in such a manner as to receive a dual layer sheet, which includes the first and second material films disposed in overlying relation with  
15 one another, therethrough. Upon passage of the dual layer sheet through the cutting means, the cutting means will substantially cutout an array of geometric shapes into the dual layer sheet. Specifically, the array of geometric shapes are defined by a plurality of geometrically shaped members and a plurality of  
20 geometrically shaped apertures formed in the first and second material films. The plurality of geometrically shaped members, which will remain at least partially secured to the respective first and second material films of the dual layer sheet, will define the geometrically shaped apertures.

25           In addition to the cutting means, the manufacturing apparatus also includes cutout raising means. The cutout raising means are specifically structured to push the geometrically shaped members in both the first and second material films of the dual layer sheet above an upper surface of the dual layer sheet. Accordingly, all  
30 of the geometrically shaped members will be disposed in a substantially raised orientation with the geometrically shaped members of the second material film extending through the geometrically shaped apertures of the first material film.

          Additionally, the apparatus of the present invention includes  
35 stagger means. The stagger means are structured to contact the second material film of the dual layer sheet in such a manner as to slide the second material film relative to the first material film. By sliding this second material film relative to the first material film, the raised, geometrically shaped members of the

first material film will be positioned in a staggered, spaced orientation relative to the raised geometrically shaped members of the second material film, thereby providing the fabric with a fuller three-dimensional appearance with each individual geometrically shaped member being visible from the upper surface of the dual layer sheet.

In accordance with the above-referenced apparatus, the method of forming the sequined, textured fabric includes the steps of overlying a first and second material film atop one another to form a dual layer sheet, cutting a plurality of geometrically shaped cutouts into the dual layer sheet in order to define the plurality of geometrically shaped members and plurality of geometrically shaped apertures, pushing the geometrically shaped members from a lower surface of the dual layer sheet into a raised position above an upper surface of the dual layer sheet, and pulling the second material film relative to the first material film so as to stagger the material films and the geometrically shaped members thereof relative to one another. Finally, the method will included the step o securing a backing material layer to the dual layer sheet so as to maintain the dual layer sheet properly and securely oriented.

It is an object of the present invention to provide a sequined, textured fabric which will be structured in a highly usable form capable of being formulated into a variety of articles.

It is an additional object of the present invention to provide a sequined, textured fabric which is substantially durable and will not easily tear, run/shift, or become unraveled during utilization.

Another object of the present invention is to provide an apparatus for the manufacture of a sequined, textured fabric which will produce the fabric in bulk at a substantially rapid manufacturing rate.

Yet another object of the present invention is to provide a textile manufacturing apparatus which will produce a sequined, textured fabric at a relatively low cost and relatively rapid rate.

An additional object of the present invention is to provide a method of manufacturing a sequined, textured fabric which eliminates the substantially labor intensive steps generally required to manufacture similar type fabrics.

### Brief Description of the Drawings

For a fuller understanding of the nature of the present invention, reference should be had to the following detailed description taken in connection with the accompanying drawings in which:

Figure 1 is a cross-sectional view of the sequined textured fabric of the present invention.

Figure 2 is a perspective view of the first embodiment of the cutting means of the present invention.

Figure 3 is a perspective view of a second embodiment of the cutting means of the present invention.

Figure 4 is a third embodiment of the cutting means of the present invention.

Figure 5 is a side view illustrating the cutout raising means and stagger means of the present invention.

Figure 6 is a side view of the preferred embodiment of the backing layer applicator means of the present invention.

Like reference numerals refer to like parts throughout the several views of the drawings.

### Detailed Description of the Preferred Embodiment

Shown throughout the figures, the present invention is directed towards a textile manufacturing apparatus, generally indicated as 10. This apparatus will be utilized to produce a sequined, textured fabric 11 which includes primarily a dual layer sheet 12. This dual layer sheet 12 will be formed from a first and a second material film layers 15 and 16, each of which is preferably a reflective laminate type of material such as a flexible plastic laminate. To form the dual layer sheet 12, the first material film 15 is positioned in contacting, overlying position atop an upper surface of the second material film 16. Included within the first and second material film layers 15 and 16 is an array of geometrically shaped cutouts. Specifically, the geometrically shaped cutouts will include a plurality of geometrically shaped members 17. These geometrically shaped members 17 are secured to the respective material films 15 and 16 by a material lip 19, and a number of geometrically shaped apertures 18 within the material films 15 and 16. In order to provide the sequined, textured appearance to the fabric 11, the

geometrically shaped members 17 of the second material film 16 will extend through the geometrically shaped apertures of the first material film 15. Additionally, to maximize the sequined appearance the geometrically shaped members 17 of the second material film 16 will be spaced from the geometrically shaped members 17 of the first material film 15, which correspond the geometrically shaped apertures 18 through which the geometrically shaped members 17 of the second material film 16 pass. As such, there is a staggered, sequined type appearance with the geometrically shaped members 17 of both material films 15 and 16 covering the upper surface 13 of the dual layer sheets 12. Further, in order to ensure that the structural integrity of the fabric 11 is maintained during use, the fabric 11 will also preferably include a backing material layer 75 secured to a lower surface 14 of the dual layer sheet 12. This backing material layer 75 will function to securely maintain the first and second material films 15 and 16 in a proper orientation to maintain the full sequined appearance on the upper surface 13 of the dual layer sheet 12, and also making the fabric 11 easier to utilize in construction of various products such as clothing. Specifically, when the material films 15 and 16 are originally interlocked they are disposed in an optimal, attractive orientation. When actually used, however, such as to make clothing or other decorative articles, the manipulations involved in constructing the articles and during its normal use tend to unravel the fabric 11. Utilizing the backing material layer 75, unraveling and shifting of the fabric 11 composition is prevented.

Turning to the manufacturing apparatus 10, it will include cutting means 20 structured and disposed to receive the dual layer sheet 12 and to substantially cutout the array of geometric shapes into the dual layer sheet 12 as it passes therethrough. Accordingly, the cutting means will form the plurality of geometrically shaped members 17 and plurality of geometrically shaped apertures 18 in both the first and second material films 15 and 16. Further, the cutting means 20 will cut out the geometrically shaped members 17 in such a manner as to leave the corresponding material lip 19 through which the geometrically shaped members 17 are secured to the respective material films 15 and 16. Turning to a first embodiment of the cutting means 20, it

will include a base panel 25 whereover the dual layer sheet 12 will pass during cutting. Positioned in confronting relation atop the base panel 25 will be a cutter panel 30. This cutter panel 30 is specifically structured to be positionable in an engaged orientation in close relation with the base panel 25, and a retracted orientation in spaced apart relation from the base panel 25. In the preferred embodiment, the cutter panel 30 will move towards the base panel 25 and into the engaged orientation through pistons, pulleys, cams, or like mechanisms. Alternatively, however, the base panel 25 or both panel will move in order to position the cutter means 20 in the engaged and retracted orientations. Included with the cutter panel 30 is at least one perforator segment 32 extending towards the base panel 25. In the preferred embodiment, a plurality of the perforator segments 32 are positioned so as to form the array of geometrically shaped cutouts. The array may be formed utilizing only a small number of perforator segments 32 which are rapid repositioned over the dual layer sheet 12 in order to form the entire array, can consist of a large number of perforator segments 32 to form the completed array over a large surface area of the dual layer sheet 12, or can preferably include one or two rows of the perforator segments 32 positioned so as to progressively form the array of geometric shaped cutouts as the dual layer sheet 12 moves thereunder.

In order to form the geometrically shaped members 17, in the material films 15 and 16, each of the perforator segments 32 will include a cutting end 33. This cutting end 33 will be specifically structured to formulate the desired geometric shape, such as a circle or strip, while not cutting through the material layer films 15 and 16 at the material lip 19 portion which secures the geometrically shaped members 17 to the material films 15 and 16. Further, the perforator segments 32, will be structured such that upon movement of the cutting means into the engaged orientation, the cutting end 33 will extend through both the first and second material films 15 and 16 in order to form identical overlying geometrically shaped members 17.

In the first embodiment of the cutting means 20, the base panel 25 will include a smooth tempered metal plate which is contacted by the perforator segments 32. In a second embodiment of the cutting means 20', however, the base panel 25 will include

a plurality of recesses 26 disposed therein in corresponding, confronting relation with the plurality of perforator segments 32 which extend from the cutter panel 30. The recesses are positioned such that the cutter end 33 of the perforator segment 32 will pass into the recess 26 when the cutting means 20' are in their engaged orientation. Further, as illustrated in the figures, a notch 34 will preferably be formed in the cutting end 33, the notch 34 corresponding the lip 19 which will remain uncut in order to secure the geometrically shaped members 17 to their respective material films 15 and 16. Also in the second embodiment of the cutting means 20', a plurality of biased press members 35 will be disposed about the perforator segments 32. Specifically, the biased press members 35 will be positioned such that when the cutting means 20' are moved into the engaged orientation, a flat press portion 36 thereof will push the dual layer sheet 12 into fixed secured position against a main upper face 28 of the base panel 25. Further, the biased press members 35, which will preferably include a spring 37, will engage the dual layer sheet 12 and push it against the base panel 25 prior to the perforator segment 32 contacting the dual layer sheet 12, thereby ensuring that slippage during cutting does not take place.

In a third embodiment of the cutting means 20", the first and second material films 15 and 16 are brought together from individual rolls to form the dual layer sheet 12, and are passed along the surface of a base member 40. Preferably, this base member 40 will include a base roller 44 which will rotate with the passage of the dual layer sheet 12 thereover and will be formed with a smooth tempered metal surface. Disposed in confronting relation with the base roller 40, of this third embodiment of the cutting means 20", is a cutter roller 46. The cutter roller 46 will include a plurality of perforator members 47 disposed about an exterior surface thereof. The perforator members 47 will be disposed in an array which will correspond the array of geometric shapes to be formed within the dual layer sheet 12. Accordingly, as the dual layer sheet 12 passes over the base roller 40, the cutter roller 46 will rotate in a direction opposite to the rotation of the base roller pressing the dual layer sheet 12 between the respective rollers 40 and 46 and forming the array of geometrically shaped cutouts within the dual layer sheet 12.

Additionally, and in order to ensure proper pushed contact between the cutter roller 46 and base roller 40, at least one of the rollers, and preferably the base roller 40, will include biasing means to bias the roller towards one another. The biasing means will preferably be in the form of a piston 43 and spring 42 which will normally urge the base roller 40 towards the cutter roller 46.

Once exiting the cutting means 20, the dual layer sheet 12 can be rolled for transfer to a separate station or can be fed directly into cutout raising means 50. Specifically, the cutout raising means 50 will be structured so as to push the geometrically shaped members 17 in both the first and second material films 15 and 16 up through an upper surface 13 of the dual layer sheet 12. In particular, the geometrically shaped members 17 of the second material film 16 will be pushed through the overlying geometrically shaped apertures 18 of the first material film 15, in turn raising the overlying geometrically shaped member 17 of the first material film 15. In a preferred embodiment, the cutout raising means 50 include a cogged wheel 52 including an array of protruding elements 53 which correspond the array of geometric shapes formed in the dual layer sheet 12. Accordingly, upon passage of the dual layer sheet 12 over the cogged wheel 52, the array of protruding elements 53 of the cogged wheel 52 will extend into the corresponding geometrically shaped apertures 18, pushing the geometrically shaped members 17 upward into a spaced elevated position over the upper surface 13 of the dual layer sheet 12. As a further step, if required, the cutout raising means 50 can also include a pair of opposing axles 54 and 55 disposed in close, spaced apart relation from one another wherethrough the dual layer sheet 12 will pass after passing over the cogged wheel 52. Preferably, the first axle 54 will be positioned such that it will contact a lower surface of the dual layer sheet and accordingly the dual layer sheet 12 will pass thereover further extending the geometrically shaped members 17 into a generally perpendicular orientation. Next, the dual layer sheet 12 will pass under the second axle 55, which will be substantially close to the first axle 54, such that the generally perpendicularly disposed geometrically shaped members 17 will contact the second axle 55 while the second axle 55 rolls over the upper surface 13 of the dual layer sheet 12, further moving the geometrically shaped members 17 to the generally perpendicular

orientation.

Next, the apparatus 10 will include stagger means 60. These stagger means 60 will be specifically structured to contact the lower surface of the dual layer sheet 12, and accordingly, contact only the second material film 16. The stagger means 60 will contact the second material film 16 in such a manner as to slide it forward at a pace more rapid than the movement of the first material film 15. Accordingly, this will dispose the first and second material films in a staggered orientation relative to one another and will move the geometrically shaped members 17 of the second material film 16 forward within the geometrically shaped apertures 18 of the first material film 15 such that they will be in spaced apart relation from the geometrically shaped members 17 of the first material film 15. In the preferred embodiment, the stagger means 60 will be in the form of a stagger roller over which the dual layer sheet 12 will pass. The stagger roller includes a non-slip exterior surface 61 which will engage the second material film causing it to move at the rate of rotation of the stagger roller 60. When the second material film 16 is engaged by the stagger roller 60, it will move more rapidly than the first material film 15 until the geometrically shaped members 17 of the second material film 16 essentially abut a wall of the geometrically shaped apertures 18 of the first material film 15 in order to pull it along.

From the stagger stage, the dual layer sheet 12 can either be disposed into a storage bin 62 for future use, can be immediately rolled for convenient storage, or can pass straight to the next stage of manufacturing, namely the backing layer applicator means 70. The backing layer applicator means 70 are structured either to accept the feed of the dual layer sheet 12 directly from the stagger means 60, from a stored roll formed after passage through the stagger means 60, or from the storage bin 62. Specifically, the backing layer applicator means will be structured so as to secure a preferably adhesive backing material layer 75 to the lower surface 14 of the dual layer sheet 12, the lower surface 14 preferably including a lower surface of both the first and second material films. The backing material layer 75 will function to secure the first and second material films 15 and 16 in their preferred, staggered orientation relative to one another during

further use of the fabric 11. Preferably, the backing layer applicator means 70 will include an applicator roller 77 wherever the backing material layer 75 will be disposed with an adhesive side of the backing material layer being exteriorly exposed so as to contact and be secured to the lower surface 14 of the dual layer sheet 12. Further, in the preferred embodiment, a confronting roller 78 may be disposed opposite the applicator roller 77 so as to flatten out the geometrically shaped members 17, facilitate adhesion of the backing material layer 75, and facilitate rolling of the entire fabric 11 onto a storage roll 80. Also, as shown in the figures, when being drawn from the storage bin 62, or a storage roller, the dual layer sheet 12 will pass through a pair of preliminary rollers 71 and 72 in order to achieve a preliminary flattening of the geometrically shaped members 17 before it passes between the applicator roller 77 and confronting roller 78, the backing material layer 75 passing to the applicator roller 77 from its own storage roll 76.

The apparatus 10 of the present invention is preferably incorporated into a method of manufacturing a sequined, textured fabric 11, the method including the steps of overlying the first material film 15 atop the second material film 16 so as to form the dual layer sheet 12, cutting a plurality of geometrically shaped cutouts into the dual layer sheet 12 so as to define a plurality of geometrically shaped members 17, secured to the material films 15 and 16 by a flexible lip 19, and a plurality of geometrically shaped apertures 18. Next, the geometrically shaped members 17 will be pushed from a lower surface 14 of the dual layer sheet 12 into a raised position above the upper surface 13 of the dual layer sheet 12, with the geometrically shaped members 17 of the second material film 16 extending through the geometrically shaped apertures 18 of the first material film 15. This step will be followed by pulling the second material film 16 relative to the first material film 15 so as to stagger the first material film 15 relative to the second material film and thereby space the geometrically shaped members 17 of the first material film 15 relative to the geometrically shaped members 17 of the second material film 16. Finally, the step of securing a backing layer to the lower surface of the dual layer sheet 12 can also be included. This step will ensure that the fabric 11 is able to

withstand significant use and manipulation without becoming unraveled or shifting. During use of the fabric 11, if a shift occurs between the material films 15 and 16, the individual geometrically shaped members will overlap one another minimizing the overall attractive appearance of the fabric. Further such staggering can easily lead to ripping or separation as one material layer is pulled or pushed excessively relative to the interconnected layer.

Now that the invention has been described,

Claims

1. A textile manufacturing apparatus to be used to manufacture a sequined, textured fabric including a first material film and a second material film, portions of the second material film protruding through the first material film, said manufacturing apparatus comprising:

cutting means structured and disposed to receive a dual layer sheet, including the first and the second material films disposed in overlying relation with one another therethrough,

said cutting means being further structured to substantially cut out an array of geometric shapes into said dual layer sheet as it passes therethrough so as to form a plurality of geometrically shaped members and a plurality of geometrically shaped apertures in the first and second material films of said dual layer sheet, each of the geometrically shaped members of said array remaining at least partially secured to their respective first and second material films of said dual layer sheet,

cut out raising means structured to push said geometrically shaped members in the first and second material films of said dual layer sheet through an upper surface of said dual layer sheet such that said geometrically shaped members are disposed in a substantially raised orientation above said upper surface of said dual layer sheet, said geometrically shaped members of the second material film extending through the overlying ones of geometrically shaped apertures of the first material film, and

stagger means structured and disposed to contact the second material film of said dual layer sheet and slide the second material film relative to the first material film such that said raised geometrically shaped members of the first material film which extend over said upper surface of said dual layer sheet are disposed in a staggered orientation relative to said raised geometrically shaped members of the second material film which extend through said geometrically shaped apertures of the first material film and over said upper surface of said dual layer sheet.

2. A textile manufacturing apparatus as recited in claim 1 wherein said stagger means pull the second material film such that said raised geometrically shaped members of the second material film abut a rim of said geometrically shaped apertures of the first material film in substantially spaced apart relation from said

raised geometrically shaped members of the first material film corresponding said overlying geometrically shaped apertures of the first material film through which said raised geometrically shaped members of the second material film pass.

5           3. A textile manufacturing apparatus as recited in claim 1 wherein said stagger means includes a stagger roller over which said dual layer sheet passes, said stagger roller being structured to rotate and including a non-slip surface such that when said non-slip surface contacts the second material film of said dual layer  
10 sheet, the second material film will be pulled relative to the first material film by said stagger roller until said raised geometrically shaped members of the second material film abut said rim of said overlying ones of said geometrically shaped apertures of the first material film.

15           4. A textile manufacturing apparatus as recited in claim 1 wherein said cut out raising means includes a cogged wheel whereover said dual layer sheet passes, said cogged wheel including an array of protruding elements corresponding said array of  
20 geometric shapes formed in said dual layer sheet such that each of said protruding elements extends into a corresponding one of said geometrically shaped apertures formed in said dual layer sheet and pushes up said geometrically shaped members within each of said corresponding ones of said geometrically shaped apertures into said substantially raised orientation through said upper surface of said  
25 dual layer sheet.

          5. A textile manufacturing apparatus as recited in claim 4 wherein said cut out raising means further includes a pair of opposing axles disposed in close spaced apart relation from one another wherethrough said dual layer sheet passes subsequent to  
30 passing over said cogged wheel, said pair of opposing axles including a first axle whereover said dual layer sheet passes and a second axle whereunder said dual layer sheet subsequently passes such that said geometrically shaped members which extend over said upper surface of said dual layer sheet will contact said second  
35 axle further pushing up said geometrically shaped members into said substantially raised orientation through said upper surface of said dual layer sheet.

          6. A textile manufacturing apparatus as recited in claim 1 further including a backing layer applicator means structured and

disposed to secure a backing material layer to a lower surface of said dual layer sheet subsequent to said dual layer sheet passing through said stagger means.

5 7. A textile manufacturing apparatus as recited in claim 6 wherein said backing layer applicator means includes an applicator roller having said backing material layer disposed thereon with an adhesive layer of said backing material layer being exteriorly exposed for passage of said dual layer sheet thereover such that said lower surface of said dual layer sheet comes into contacting  
10 engagement with said exposed adhesive layer of said backing material layer on said applicator roller.

8. A textile manufacturing apparatus as recited in claim 1 wherein said cutting means comprises:

15 a base panel whereover said dual layer sheet passes,  
a cutter panel disposed in confronting relation atop said base panel, said cutter panel being structured to be positionable in an engaged orientation, in close relation with said base panel, and a retracted orientation, in spaced apart relation from said base panel,

20 said cutter panel including at least one perforator segment extending from said cutter panel towards said base panel, and  
said perforator segment including a cutting end structured to form said geometrically shaped members in said dual layer sheet upon said cutter panel entering said engaged orientation.

25 9. A textile manufacturing apparatus as recited in claim 8 wherein said cutting means includes a plurality of said perforator segments structured and disposed to form said array of geometric shapes in said dual layer sheet.

30 10. A textile manufacturing apparatus as recited in claim 9 wherein said base panel includes a smooth tempered metal plate which said cutting end of each of said perforator segments contacts when said cutter panel is disposed in said engaged orientation.

35 11. A textile manufacturing apparatus as recited in claim 9 wherein said base panel includes a plurality of recesses disposed in corresponding, confronting relation with said plurality of perforator segments such that said cutting end of said perforator segments extend into said corresponding recesses of said base panel upon said cutter panel being disposed in said engaged orientation.

12. A textile manufacturing apparatus as recited in claim 11

wherein said cutter panel includes a plurality of biased press members disposed about said perforator segments, said press members being structured and disposed to push said dual layer sheet into fixed, secured position against a main upper face of said base panel upon said cutter panel entering said engaged orientation.

5 13. A textile manufacturing apparatus as recited in claim 1 wherein said cutting means comprises:

a base member whereover said dual layer sheet passes,

10 a cutter roller, said cutter roller including a plurality of perforator members disposed about an exterior surface thereof, said perforator members being disposed in an array which corresponds said array of geometric shapes to be formed in said dual layer sheet, and

15 said base member and said cutter roller being disposed in close, contacting relation with one another such that upon rolling movement of said cutter roller said perforator members move into engaged, contacting relation with said base member so as to form said geometrically shaped members in said dual layer sheet.

20 14. A textile manufacturing apparatus as recited in claim 13 wherein said base member includes biasing means structured and disposed to bias said base member towards said cutter roller.

25 15. A textile manufacturing apparatus as recited in claim 14 wherein said base member includes a base roller structured to rotate in a direction opposite to the rotation of said cutter roller.

16. A sequined, textured fabric comprising:

a first material film,

a second material film,

30 said first material film and said second material film each including an array of geometrically shaped cut outs therein,

said geometrically shaped cut outs including a plurality of geometrically shaped members, each of said geometrically shaped members defining a geometrically shaped aperture in said material film and being secured to said material film by a material lip,

35 said first material film being disposed in contacting, overlying position atop an upper surface of said second material film, said geometrically shaped members of said second material film extending through said geometrically shaped apertures defined in said first material film and being disposed in spaced apart

relation from said geometrically shaped members of said first material film corresponding said geometrically shaped apertures of said first material film through which said geometrically shaped members of said second material film pass, and

5 a backing material layer secured to a lower surface of said second material film so as to securely maintain said first material film and said second material film with said geometrically shaped members of said second material film disposed in said spaced apart relation from said geometrically shaped members of said first  
10 material film.

17. A sequined, textured fabric as recited in claim 16 wherein said backing material layer is secured to said lower surface of said second material film and a lower surface of said first material film through said geometrically shaped apertures of  
15 said second material film.

18. A sequined, textured fabric as recited in claim 16 wherein said first and said second material films are formed of a flexible plastic laminate.

19. A method of manufacturing a sequined, textured fabric including a first and a second material films, portions of the second material film protruding through the first material film, said method comprising the steps of:

overlying said first material film atop said second material film so as to form a dual layer sheet,

25 cutting a plurality of geometrically shaped cut outs into said dual layer sheet so as to define a plurality of geometrically shaped members, secured to the material films by a flexible lip, and a plurality of geometrically shaped apertures,

pushing said geometrically shaped members from a lower surface  
30 of said dual layer sheet into a raised position above an upper layer of said dual layer sheet, said geometrically shaped members of said second material film extending through said geometrically shaped apertures of said first material film, and

pulling said second material film relative to said first  
35 material film so as to stagger said first material film relative to said second material film causing said geometrically shaped members of said second material film to be disposed in spaced apart relation from said geometrically shaped members of said first material film corresponding said geometrically shaped apertures of

said first material film through which said geometrically shaped members of said second material film pass.

20. A method of manufacturing a sequined, textured fabric as recited in claim 19 further including the step of securing a  
5 backing layer to said lower surface of said dual layer sheet.

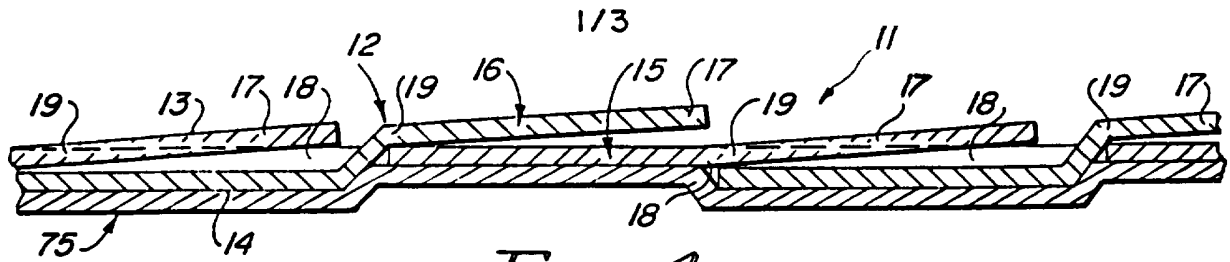

FIG. 1

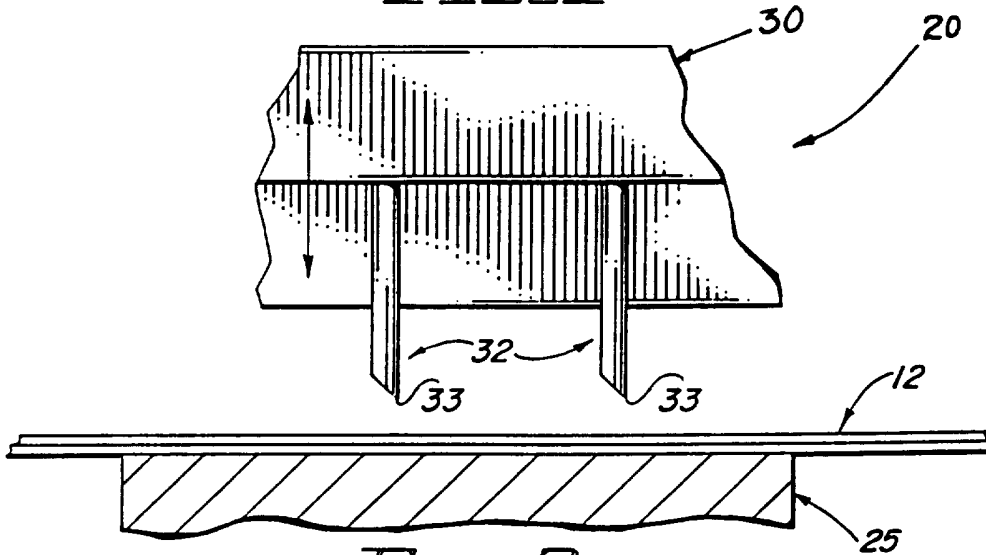

FIG. 2

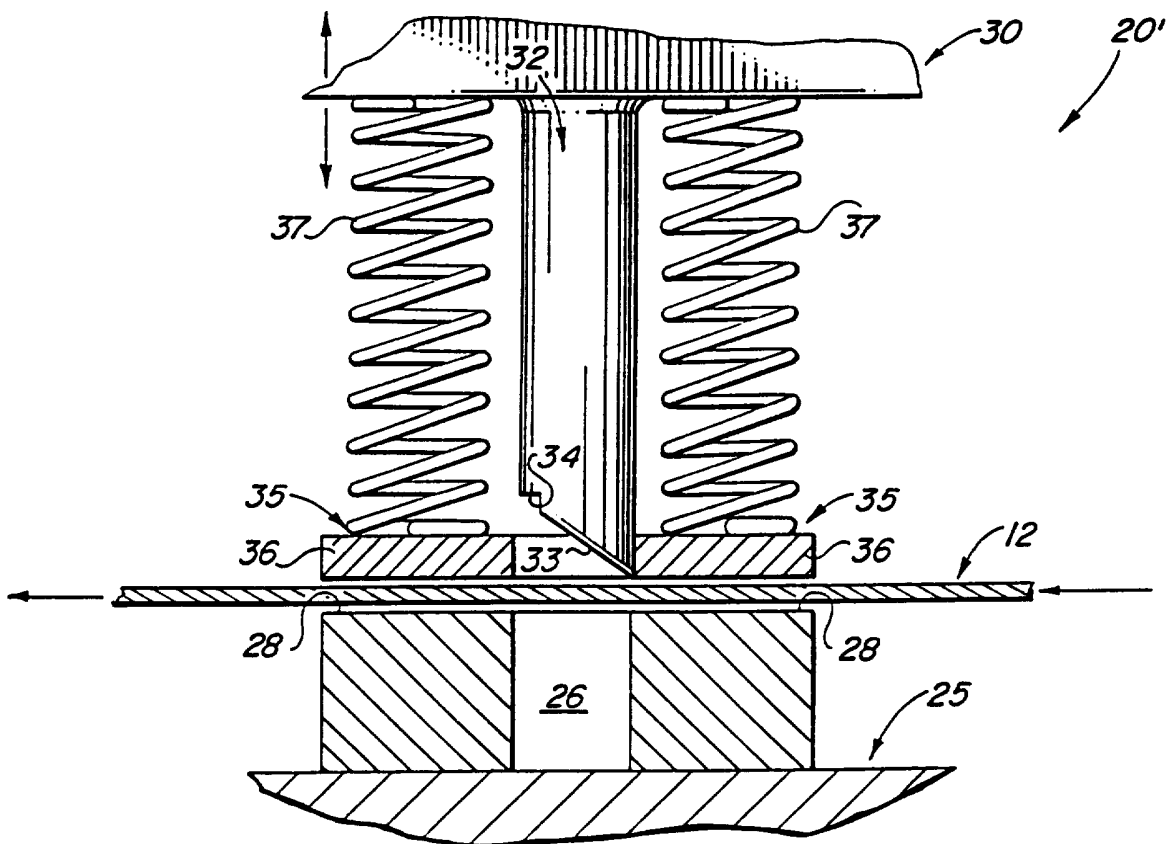

FIG. 3

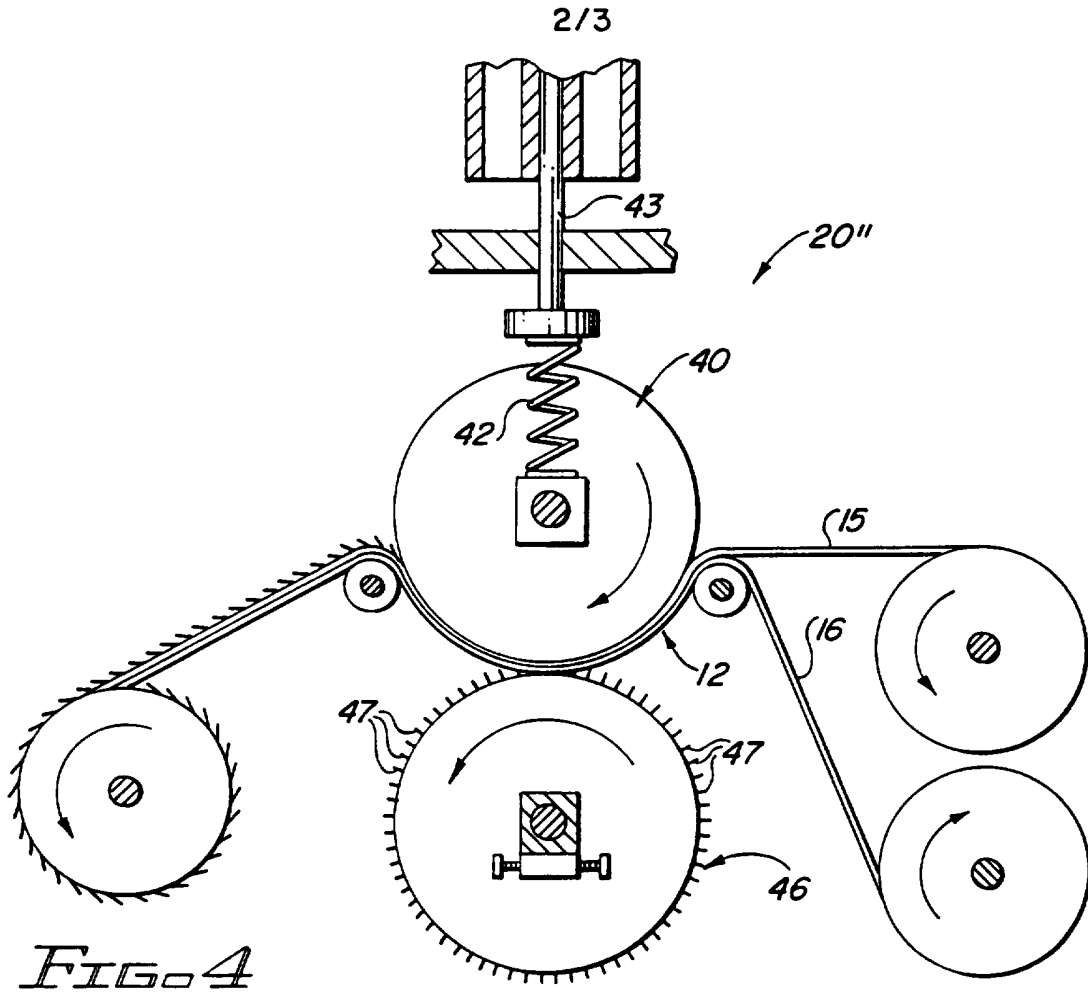

FIG. 4

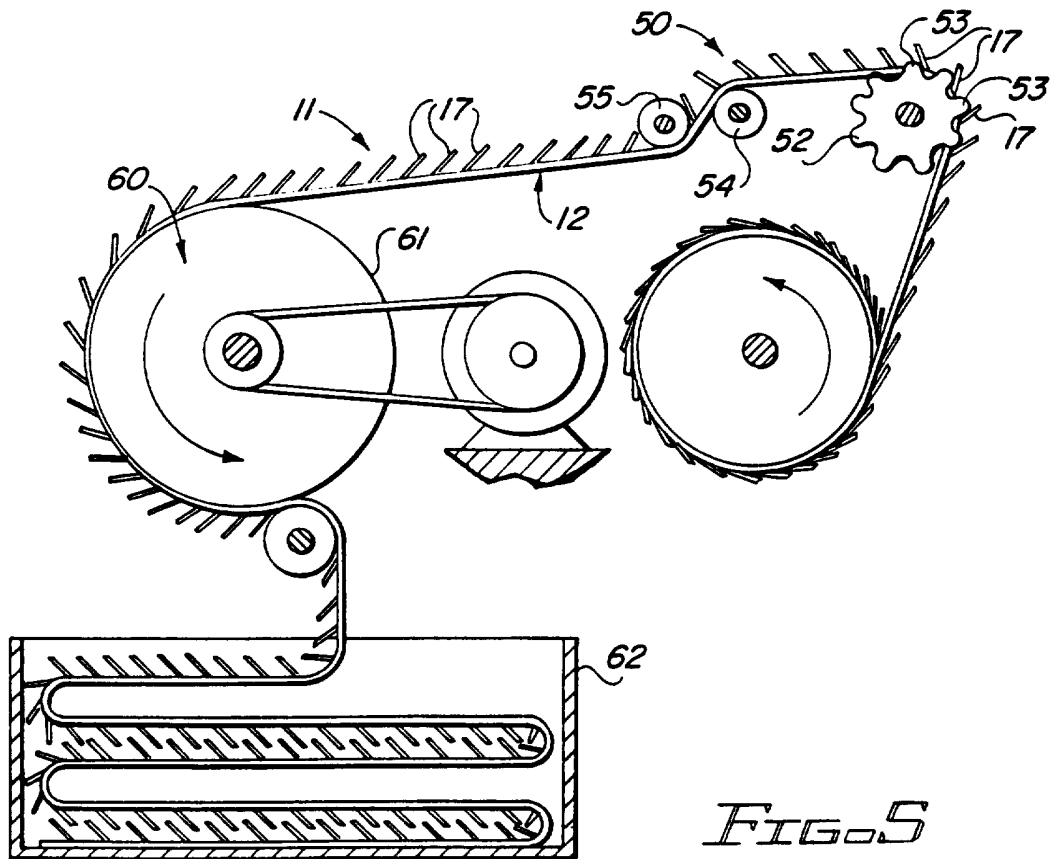

FIG. 5

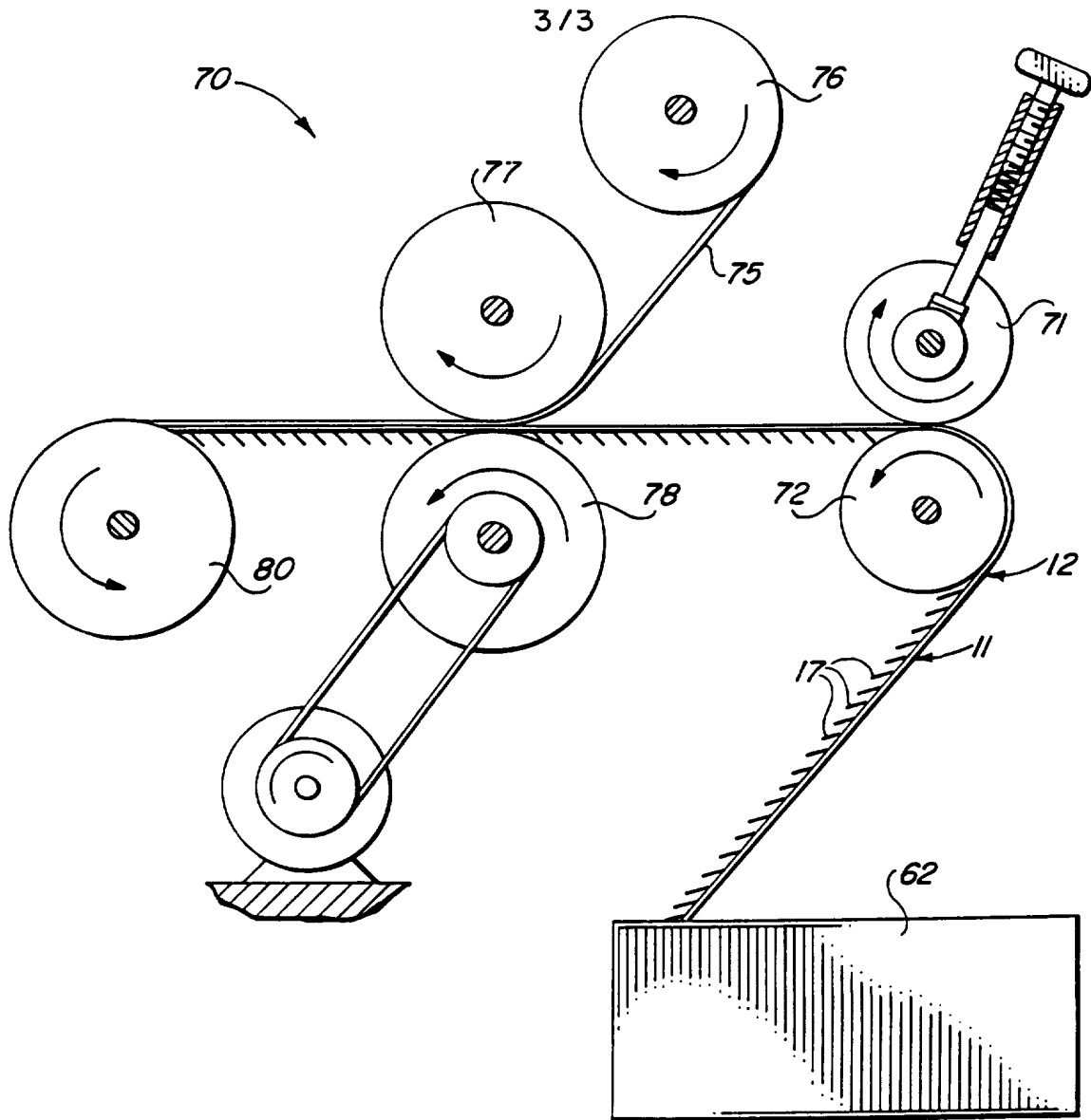

FIG. 6