

(19) World Intellectual Property Organization
International Bureau



(43) International Publication Date
10 May 2001 (10.05.2001)

PCT

(10) International Publication Number
WO 01/33504 A1

(51) International Patent Classification⁷: G06T 7/00,
G01B 11/00, B07C 1/06, B25J 9/16, G03F 9/00

(74) Agents: POWSNER, David, J. et al.; Nutter, McClennen
& Fish LLP, One International Place, Boston, MA 02110-
2699 (US).

(21) International Application Number: PCT/US00/29952

(81) Designated State (*national*): JP.

(22) International Filing Date: 30 October 2000 (30.10.2000)

(25) Filing Language: English

(84) Designated States (*regional*): European patent (AT, BE,
CH, CY, DE, DK, ES, FI, FR, GB, GR, IE, IT, LU, MC,
NL, PT, SE).

(26) Publication Language: English

(30) Priority Data:
60/162,521 29 October 1999 (29.10.1999) US

Published:
— With international search report.
— Before the expiration of the time limit for amending the
claims and to be republished in the event of receipt of
amendments.

(71) Applicant: COGNEX CORPORATION [US/US]; One
Vision Drive, Natick, MA 01760 (US).

(72) Inventor: SILVER, William; 25 Arrowhead Road, We-
ston, MA 02493 (US).

For two-letter codes and other abbreviations, refer to the "Guid-
ance Notes on Codes and Abbreviations" appearing at the begin-
ning of each regular issue of the PCT Gazette.

(54) Title: METHOD AND APPARATUS FOR LOCATING OBJECTS USING UNIVERSAL ALIGNMENT TARGETS

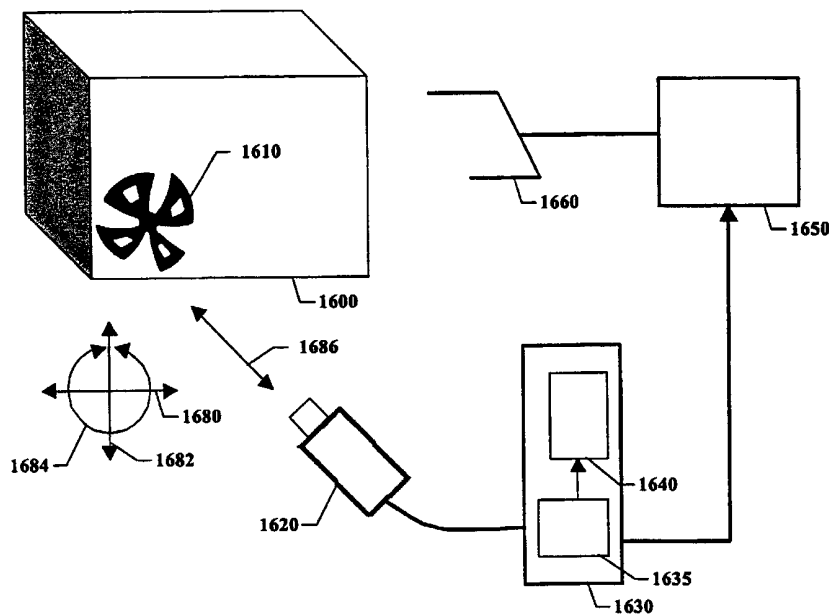

Apparatus for locating objects using a UAT

(57) Abstract: A method and apparatus for locating objects by means of machine vision alignment using cooperative targets. Novel cooperative targets are used that have substantial performance advantages. Alignment methods having non-translation alignment capabilities are used, such as geometric pattern matching, cooperating with suitable targets to perform alignment in non-translation degrees of freedom, such as orientation and size.



WO 01/33504 A1

Method and Apparatus for Locating Objects Using Universal Alignment Targets

1 **Related Application Data:**

2 This application claims priority to Provisional Patent Application No. 60/162,521, filed in
3 the U.S. Patent and Trademark Office on October 29, 1999, the content of which is hereby
4 expressly incorporated by reference herein in its entirety.

5

6 **Copyright Notice:**

7 The disclosure of this patent document contains material that is subject to copyright
8 protection. The copyright owner has no objection to the facsimile reproduction by anyone of the
9 patent document or the patent disclosure, as it appears in the United States Patent and Trademark
10 Office patent file or records, once a patent is issued on this application, but otherwise reserves all
11 copyright rights whatsoever.

12

13 **Field of the Invention:**

14 This invention relates to automated visual alignment, and particularly to locating objects
15 using automated visual alignment.

16

17 **Background of the Invention:**

18 The ability to determine the position and/or attitude of an object is of considerable
19 practical importance in many applications, including industrial manufacturing, robot guidance,
20 intelligent transportation systems, mail and parcel handling, and many others. Position might

1 include up to three degrees of freedom (e.g., up-down, in-out, and side-ways), and the three
2 degrees of freedom of attitude (e.g., pitch, yaw, and roll). Together, these six degrees of freedom
3 can be used to describe what can be referred to as the “location” or “pose” of an object. Note
4 that here, “location” or “pose” can mean more than just position in three spatial dimensions – it
5 can also include information as to the other non-translational degrees of freedom, such as skew,
6 perspective, aspect-ratio, and many other more exotic non-translational degrees of freedom. In a
7 two-dimensional plane, position includes two translation degrees of freedom (e.g., up-down and
8 side-ways), and at least one non-translation degree of freedom, such as “orientation” (a rotation
9 degree of freedom), and possibly skew, aspect ratio, size, and others.

10 It is well-known to use machine vision to locate objects at a distance. A digital image of a
11 scene containing an object to be located is formed by any suitable apparatus, for example
12 consisting of visible light illumination, a CCD camera, and a video digitizer. The digital image is
13 then analyzed by a suitable image analysis device, for example consisting of a digital signal
14 processor or personal computer running software that implements a suitable method for
15 identifying and locating image patterns that correspond to the object of interest. The analysis
16 results in certain parameters that describe the pattern in the image that corresponds to the object,
17 or a suitable portion of the object, in the scene. These parameters might include position,
18 attitude, and size of the pattern in the image. These parameters are then used to compute the
19 location (pose) of the object using well-known mathematical formulas.

20 There are many methods known in the art for analyzing digital images to determine one
21 or more of the pattern parameters, including blob analysis, normalized correlation, Hough
22 transforms, and geometric pattern matching. Numerous other methods have been used or
23 proposed in commercial practice or in academic literature.

24 The process of determining object location (pose) by machine vision can be referred to in
25 various ways, including “alignment”, “registration”, “pattern recognition”, and “pattern
26 matching”. For present purposes herein, those terms are equivalent, and so herein the term
27 “alignment” shall be used to refer to any such process. Any object, or portion of an object, that
28 gives rise to the pattern in the image to be analyzed shall be called an “alignment target”, or
29 simply a “target”.

1 Most machine vision alignment applications require locating targets having a shape
2 determined by engineering considerations that are largely independent of the needs of automated
3 visual alignment. In these cases, the objects contain no special markings or components specially
4 adapted to aid the alignment method. Consequently, the alignment method must work with
5 whatever object shape is given. There are many applications, however, where the alignment
6 target can be engineered specifically for that purpose. Examples include fiducial marks on
7 printed circuit boards, registration marks etched on silicon wafers, and “bull’s eye” targets used
8 by the United Parcel Service on package labels. A target that has been engineered to aid machine
9 vision alignment can be called a “cooperative target.” In contexts where it is clear that a target
10 has been engineered for alignment, the modifier “cooperative” is sometimes omitted, but
11 “cooperative” is understood.

12 Although alignment methods have an extensive literature and commercial history,
13 relatively little work has been done on understanding the effect of target shape on alignment
14 performance. The work is almost entirely restricted to shapes composed of circles and polygons,
15 to the effect of such shapes on binary image analysis methods, to translation-only (i.e., horizontal
16 and vertical) alignment, and to accuracy criteria only.

17 Rotationally symmetric targets, primarily circles and “bull’s-eye” patterns, have long
18 been a favorite in the academic literature. In a 1974 paper, for example, W. Makous “Optimal
19 Patterns for Alignment”, in *Applied Optics*, Vol. 13, No. 3, states that “a bull’s-eye pattern of
20 regularly alternating black and white rings would be optimal for visual alignment in two
21 dimensions.” Twenty four years later, in a 1998 paper entitled “Design of Shapes for Precise
22 Image Registration”, in *IEEE Trans. on Information Theory*, Vol. 44, No. 7, Bruckstein,
23 O’Gorman, and Orlitsky state that “Experimental tests and ... theoretical developments ... led to
24 the conclusion that the ‘bull’s-eye’ fiducial is indeed a very good, robust and practical location
25 mark.”

26 Rotationally symmetric targets suffer from a number of limitations, however, that have
27 not been anticipated in the prior art. First, such targets contain no information for measuring
28 orientation. This has been considered an advantage, based on the assumption that alignment
29 methods would fail under orientation misalignment unless the target is rotationally symmetric,

1 but the recent advent of practical methods for orientation alignment have created a need for
2 targets that convey substantial orientation information.

3 A second limitation of rotationally symmetric targets, such as the “bull’s eye” pattern, is
4 that circles and arcs of circles are extremely common in manufactured items, and one cannot
5 guarantee that such shapes will not appear in the field of view containing the target. The
6 appearance of such a shape in the same field of view as a target composed of circles or arcs of
7 circles results in potential confusion for the alignment method, and this confusion usually leads
8 to higher recognition error rates under variations in image quality typically encountered in an
9 industrial environment.

10 A third limitation of rotationally symmetric targets is that they are often not good choices
11 for measuring size, what might be called “size alignment”. While such a target does contain
12 plenty of information for conveying size, the concentric circular boundaries match each other
13 perfectly at many different sizes. At the correct size the overall target match will be higher than
14 at any of the wrong sizes, but the matches at the wrong sizes are sometimes good enough to
15 create confusion under realistic conditions of image degradation. This “self-confusion” can lead
16 to higher recognition error rates. Furthermore, this self-confusion generally requires that any
17 practical alignment method must examine the “size” degree of freedom more carefully to avoid
18 error, which increases recognition time.

19 The academic literature has also considered using as alignment targets simple polygons
20 such as squares and diamonds, as well as complex sequences of stripes that are optimal for 1D or
21 2D alignment in some theoretical sense, but are almost impossible to manufacture.

22 Known targets in commercial use include simple geometric shapes such as circles, bull’s-
23 eyes, squares, crosses, two squares touching at a corner, and patterns consisting of a cross
24 embedded in a circle.

25 In the semiconductor industry, significant attention has been given to the engineering of
26 targets used to achieve the extreme accuracy needed to register the many layers created during
27 wafer processing. Early targets consisted of interleaved comb structures, which were used by
28 human operators in manual alignment systems prior to the advent of machine vision alignment.

1 More recently, manufacturers have used squares, concentric “box-in-box” shapes, crosses,
2 circles, rings, bull’s-eyes, and various other shapes comprised of rectilinear or circular features.
3 Much of the prior art in semiconductors is concerned with process issues such as 3D structure,
4 edge profiles, circuit design rules, and resist flow.

5 Prior art cooperative targets suffer from one or more of the following limitations:

- 6 • Target features are sometimes inadequate for providing sufficient information
7 regarding non-translation degrees of freedom (e.g., orientation and size).
- 8 • Reduced information is available when straight-line features are aligned (accidentally
9 or otherwise) with the pixel grid.
- 10 • Confusion and consequent reduced reliability result from use of circles, circular arcs,
11 line segments, or right angles, which are common in manufactured objects, and
12 therefore may be confused by the alignment method with other patterns in the scene.
- 13 • Reduced reliability results from use of fine target features that do not survive a
14 manufacturing process.
- 15 • Confusion and consequent reduced reliability result from target shapes that are “self-
16 confusing”, i.e., that match themselves too well when translated, rotated, or changed
17 in size.
- 18 • Reduced alignment speed results from target shapes that cannot be identified
19 unambiguously by their coarsest features.

20 For a number of reasons these limitations generally have not been serious for past use of
21 machine vision. The alignment methods that have been available in the past, such as blob
22 analysis and normalized correlation, had not been accurate enough (i.e., could extract only
23 limited information from an image) to expose subtle limitations of the targets. Few practical
24 methods existed for determining non-translation degrees of freedom, and those that were known
25 were not widely used due to cost, reliability, or performance problems. Machine vision was often
26 a new and challenging manufacturing technology, and so emphasis was placed on basic

1 functionality and not on squeezing high performance from the equipment. In electronics and
2 semiconductor applications, among the largest users of machine vision, the coarser device
3 geometries of the past placed limited demands on machine vision alignment.

4 Recent developments have created a need for a new breed of cooperative targets:

- 5 • The commercial availability of practical, highly accurate alignment methods capable of
6 aligning non-translation degrees of freedom, including orientation and size, has created a
7 need for targets engineered to provide sufficient information in all such degrees of freedom.
- 8 • Expanding experience with machine vision alignment has shown that increased error rates
9 often result from targets that can be confused with similar shapes in the field of view, or are
10 self-confusing in one or more degrees of freedom. Thus, there is a need for targets not based
11 on common features such as lines, right-angles, and circles, and for targets specifically
12 engineered to minimize or eliminate self-confusion in all degrees of freedom.
- 13 • Shrinking sizes and tighter tolerances in manufactured goods, particularly in semiconductors
14 and electronics, are placing increasing demands on accuracy, speed, and robustness of
15 machine vision alignment. Consequently, there is a need to reconsider the often-neglected
16 role of target shape, and produce targets that cooperate with practical alignment methods to
17 achieve best performance.

18 The need for new cooperative targets not subject to the limitations of the prior art leads to a need
19 for new methods for engineering such targets. Prior art methods for engineering targets suffer
20 from one or more of the following limitations:

- 21 • The known target engineering methods address only translation alignment, not other
22 degrees of freedom such as orientation and size.
- 23 • The known target engineering methods are based on a theoretical analysis of absolute
24 accuracy, which to avoid intractable complexity, requires unrealistic simplifying
25 assumptions about image quality, requires that target shape be restricted to simple shapes
26 composed of circles and rectilinear edges, and requires the use of simple binary
27 alignment methods, such as blob centroid.

- 1 • The known target engineering methods do not consider alignment speed.
- 2 • The known target engineering methods do not consider alignment reliability under
3 practical conditions of image variation and process degradation.
- 4 • The known target engineering methods do not consider confusion with other patterns and
5 self-confusion.

6 Consequently there is a need for a new method for engineering alignment targets.

7 Another factor contributing to reduced performance of known cooperative alignment
8 targets is insufficient precision in known methods for rendering such targets. Without the ability
9 to render a cooperative alignment target at very high precision, an alignment target engineered to
10 address the problems of the prior art would not perform optimally. Consequently, it is necessary
11 to be able to render such targets in various forms, including bitmap images, at very high
12 precision. In the prior art, methods for rendering shapes accurately on a discrete grid have been
13 studied extensively for graphics applications, where they are generally referred to as anti-aliasing
14 methods. These methods produce pleasing graphics for human observation, but achieving the
15 extreme accuracy and flexibility needed for machine vision alignment applications is difficult.

16 In the machine vision prior art, several methods have been used to render binary shapes
17 on discrete grids. In one method, pixels along the shape boundary are given a gray value
18 corresponding to the fraction of the pixel's area that falls on either side of the boundary. This
19 method suffers from several limitations:

- 20 • The computations are complex, resulting in very slow rendering that makes
21 automated testing using thousands of synthetically generated images impractical.
- 22 • The method assumes an unrealistically ideal sensor model, resulting in loss of
23 accuracy. Attempts to improve the sensor model by post-processing the rendered
24 image are also limited in accuracy due to grid quantization.
- 25 • The method is impractical for complex shapes that are not composed of straight-line
26 segments.

1 In another known rendering method, a binary image is rendered at much higher resolution
2 than that needed for the target rendering. This high-resolution image is then filtered and sub-
3 sampled to produce the final rendering. While such a method can be quite accurate in principal,
4 computer time and memory limitations make truly high accuracy impractical.

5

1 Summary of the Invention

2 It is well-known in the prior art to cause a cooperative target to appear on an object to be
3 located, place the object within the field of view of a camera or other suitable image formation
4 device, capture an image of the object bearing the target, and analyze the image using an
5 alignment method to determine the x-y position of the target in the image.

6 The invention includes a method and apparatus for locating objects by means of machine
7 vision alignment using cooperative targets. The method and apparatus provides significant
8 improvements over the prior art. In one general aspect, the invention uses novel cooperative
9 targets that have substantial performance advantages over those used in the prior art. In another
10 general aspect, the invention uses alignment methods having non-translation alignment
11 capabilities, such as geometric pattern recognition, cooperating with suitable targets to perform
12 alignment in non-translation degrees of freedom, such as orientation and size.

13 The invention includes a novel set of criteria for evaluating alignment targets for
14 accuracy, speed, yield (robustness), and ease of use. The accuracy criteria of the invention are
15 based on a quantitative analysis of target boundary shape that has several advantages over prior
16 art methods:

- 17 • The accuracy criteria of the invention can be used for essentially arbitrary shapes;
- 18 • The accuracy criteria of the invention provide estimates of the information content of
19 a cooperative target, independent of any specific alignment method; and
- 20 • The accuracy criteria of the invention can evaluate targets for their capacity to
21 accurately align non-translation degrees of freedom, such as orientation and size.

22 The accuracy criteria of the invention also include a quantitative measure of the tendency
23 of a target to contribute to loss of accuracy due to accidental alignment with the pixel grid of the
24 machine vision system, a phenomenon referred to herein as “grid degeneracy”. This phenomenon
25 has been recognized in academic research, although useful remedies appear not to have been
26 investigated, and many cooperative targets in current use suffer from this problem.

1 Although speed criteria are apparently unknown in the prior art, an aspect of the
2 invention includes qualitative criteria based on certain common characteristics of most practical
3 alignment methods in use, which are in turn loosely based on principals of information content.

4 Yield criteria are also apparently unknown in the prior art, with the exception of targets
5 used for wafer fabrication in the semiconductor industry, where the criteria are specific to wafer
6 processing. For high yield (low error rates), an aspect of the invention considers the ability to
7 survive manufacturing processes and other environmental conditions. Another aspect of the
8 invention includes criteria relating to potential errors caused by self-confusion and background
9 confusion.

10 The ease-of-use criteria of the invention require that targets be easy to render on the
11 objects to be located, easy to teach to the machine vision alignment method, and easy to analyze
12 using the criteria of the invention. To satisfy these ease-of-use criteria, the invention uses targets
13 that are defined by a set of algebraic formulas.

14 The invention includes a novel method of accurately rendering algebraically defined
15 shapes that can be used to render alignment targets, or for other purposes. The method can render
16 shapes as a bitmap image for machine vision alignment training, for computer display for human
17 observation, and for computer printout for documentation. The method can aid in rendering
18 targets on the objects to be located by providing input to a computer-aided design (CAD) system,
19 or by directly controlling devices such as laser engravers. The rendering method of the invention
20 is fast, extremely accurate, and can handle substantially arbitrary shapes.

21 The rendering method according to the invention includes two key steps: first, targets are
22 defined by a real-valued function of position in the real plane that gives the distance from that
23 position to the nearest point on a target boundary. The function gives distance as a positive value
24 for points inside the figure, and as a negative value for points outside the figure; and second, an
25 edge model is used to map distance to real-valued image intensity. By choosing appropriate edge
26 model parameters, edge sharpness, focus, video gain, and noise can be modeled. Other steps are
27 used with these two key steps to provide a complete rendering method. In a preferred
28 embodiment, the rendering method of the invention uses high-precision floating point arithmetic
29 to estimate real-valued functions on the real plane, and only converts to a discrete grid as the

1 final step. The result is the ability to control the position, orientation, and size of the final
2 rendering to extremely high precision.

3 The invention includes a novel method for engineering alignment targets that satisfy the
4 above set of criteria of the invention. By contrast, known methods generally try to analyze a set
5 of specific shapes, such as a circle, square, and diamond, and then simply choose the best one.
6 Alternatively, in some known methods, a single parameter such as aspect ratio might be
7 optimized according to some criteria. The method of the invention for engineering alignment
8 targets, by contrast, starts with a simple shape and then refines the initial shape in a series of
9 steps, where each such step produces a different shape, derived from the previous step, that
10 resolves some deficiency of that shape.

11 In one embodiment of the method for engineering alignment targets, the initial shape
12 contains radial features, which carry orientation information but not size, and circular features,
13 which carry size information but not orientation. As recognized by the invention, this
14 independence of radial and circular features allows orientation and size performance to be
15 adjusted independently.

16 In another embodiment of the method, the starting shape is defined algebraically using
17 polar coordinates. In a preferred embodiment, the starting shape is a "fan".

18 In a preferred embodiment, the series of steps includes at least one step whose purpose is
19 to achieve at least one of the following goals:

- 20 • Increase boundary perimeter to improve accuracy. In a preferred embodiment,
21 perimeter is increased by adding holes.
- 22 • Balance orientation and size accuracy, so that the target is not overly biased towards
23 one degree of freedom at the expense of the other.
- 24 • Reduce or eliminate rotational symmetry.
- 25 • Reduce or eliminate orientation self-similarity.
- 26 • Reduce or eliminate size self-similarity.

- 1 • Reduce or eliminate grid degeneracy.
- 2 • Reduce or eliminate features that are common in manufactured items, such as circles,
3 circular arcs, straight lines, and right angles.

4 The alignment target engineering method of the invention provides at least the following
5 benefits:

- 6 • The alignment target engineering method of the invention allows objective,
7 quantitative comparison of the ability of different shapes to convey alignment
8 information in all relevant degrees of freedom, including translation, orientation, and
9 size.
- 10 • The alignment target engineering method of the invention avoids fruitless theoretical
11 attempts to determine absolute accuracy, and instead allows analysis of arbitrary
12 shapes with no assumptions about image quality or the alignment method to be used.
- 13 • The alignment target engineering method of the invention takes into account the
14 effect of target shape on the speed of practical alignment methods in common use.
- 15 • The alignment target engineering method of the invention takes into account the
16 effect of potential confusion with other patterns, and self-confusion, on alignment
17 reliability.

18 The invention includes specific alignment targets that have at least one of the following
19 attributes:

- 20 • They satisfy the invention's evaluation criteria.
- 21 • They result from the use of the invention's engineering method.
- 22 • They have no significant rotational symmetry.
- 23 • They have no significant orientation or size self-similarity.

- 1 • They are not primarily composed of circles, circular arcs, straight lines, or right
2 angles.

3 In one embodiment, the specific alignment targets are shapes consisting of at least one
4 “generalized polar polygon.” A generalized polar polygon is a plane figure that is a polygon with
5 optionally rounded vertices when drawn in polar coordinates, keeping in mind that all
6 coordinates $(r, \theta + 360^\circ n)$, for integer n , are the same point. Such a figure will include radial
7 lines, circular arcs, and spiral segments when drawn in the Cartesian plane.

8 In another embodiment, the specific alignment targets are members of a family of “fan”
9 shapes.

10 In a preferred embodiment, the targets are fan shapes that satisfy all, or almost all, of the
11 evaluation criteria established by the invention. These are novel shapes that have no prior history
12 in mathematics or practical arts. Any target that substantially satisfies all of the evaluation
13 criteria is called a “Universal Alignment Target” (UAT).

14

1 **Brief Description of the Drawings**

2 The invention will be more fully understood from the following detailed description, in
3 conjunction with the following figures, wherein:

4 Figure 1 shows a typical cooperative target in common use, and illustrates some of the basic
5 properties of targets considered by the invention.

6 Figure 2 illustrates how the figures of merit used for the accuracy criteria are computed.

7 Figure 3 illustrates an accidental alignment of a target to the machine vision system's pixel grid,
8 which results in loss of information called a "grid degeneracy".

9 Figure 4 illustrates the alignment speed criteria.

10 Figure 5 illustrates the alignment yield criteria.

11 Figure 6 illustrates a target defined by a set of algebraic formulas to satisfy the ease of use
12 criteria.

13 Figure 7 illustrates a preferred rendering method according to the invention.

14 Figure 8 shows an edge model used in a preferred embodiment of the rendering method.

15 Figure 9 illustrates some common alignment targets that are used as a reference point in the
16 engineering of novel, high performance targets according to the invention.

17 Figure 10 illustrates a starting shape, the "primitive fan", according to a preferred embodiment of
18 the target engineering method of the invention.

19 Figure 11 shows the first refinement in the fan series, the "simple fan".

20 Figure 12 illustrates the next refinement step, the "balanced fan."

21 Figure 13 illustrates the next refinement, the "balanced asymmetric fan."

- 1 Figure 14 illustrates the next refinement, the first version of the “balanced radically asymmetric
- 2 fan.”
- 3 Figure 15 illustrates the final alignment target shape, the “balanced radically asymmetric fan”,
- 4 which is considered a superb universal alignment target.
- 5 Figure 16 illustrates an apparatus for locating objects using cooperative targets.

1 Detailed Description of the Drawings

2 Figure 1 shows a typical cooperative target in common use, and illustrates some of the basic
3 properties of targets considered by the invention.

4 Practical targets are characterized by discontinuities of some quantity (i.e. brightness, texture) at
5 some appropriate granularity (spatial resolution). These discontinuities are boundary contours 100
6 (sometimes called edges), physical or subjective, that separate roughly uniform regions 110 and
7 120. Although it is possible to imagine targets with no uniform regions and no discontinuities,
8 they are hard to fabricate and generally unreliable due to the well-known observation that image
9 shading is much less consistent under real-world variations than the shape and position of the
10 boundaries. Thus from this point forward we consider only targets characterized by boundaries
11 separating roughly uniform regions.

12 We avoid all consideration of shading in the engineering of a target and consider only the shape
13 of the boundaries. All shadings that can produce the boundaries are considered equivalent, and
14 for simplicity we assume binary shading on the real plane. When targets are rendered on a
15 discrete grid, however, the boundaries must be carefully shaded in gray-scale to convey accurate
16 boundary position and orientation information.

17 Information about a target's position is to be found exclusively along the boundary contours, for
18 example 100. In uniform or uniformly-varying regions, for example 110 and 120, no position
19 information is available for the simple reason that all points in such regions look the same. This
20 is a fact of geometry that is independent of the alignment method—even area-based methods
21 such as normalized correlation ultimately get their position information from these boundaries.

22 It is well-known that the shape of the boundary contours has some bearing on the ability of a
23 target to provide information for specific degrees of freedom. For example it has long been
24 observed that a circle cannot be used to measure rotation, a corner cannot be used to measure
25 size, and a rectangle provides more translation information normal to its long axis than its short
26 axis. These bits of intuition can be formalized, resulting in formulas for computing *figures of*
27 *merit* that allow one to assess quantitatively the ability of a given shape to measure a given
28 degree of freedom. The figures of merit are non-negative unbounded real numbers. For rotation

1 and size, a single number each is defined. For translation, the figure of merit is a function of
2 direction.

3 Alignment accuracy is determined by a combination of factors, the most important being the
4 intrinsic capabilities of the alignment method, the information content of the target, and the
5 magnitude of image degradation. The figures of merit measure the information content of the
6 target only, and thus do not directly determine accuracy. Their value is that they allow targets to
7 be compared quantitatively and independent of the alignment method in use.

8 Figure 2 illustrates how the figures of merit are computed. Let the parameter s be arc length
9 along a contour. Consider a small segment 200 of contour of length ds , at position defined by the
10 vector $\mathbf{p}(s)$ 210 relative to some point \mathbf{cp} 220. Define the unit vector $\mathbf{u}(s)$ 240 normal to the
11 contour at \mathbf{p} , and the unit vector $\mathbf{u}(\theta)$ 230 in direction θ all as shown in figure 2.

12 The contribution to the figure of merit of a given degree of freedom by the segment is the area
13 swept out by the segment per unit change in the degree of freedom. For rotation and size the
14 change is about the point \mathbf{cp} , further defined below. Thus segments oriented parallel to the
15 direction of motion induced by a change in the degree of freedom sweep no area and contribute
16 nothing to the figure of merit, and segments oriented normal to the direction of motion contribute
17 the most. For rotation and size, the contribution is proportional to distance from \mathbf{cp} , which is
18 consistent with one's intuition.

19 From this discussion, the rotation, size, and translation figures of merit for any contour can be
20 written as follows (note that the vector cross product in 2 dimensions produces a scalar):

$$21 \quad R = \oint |\mathbf{u}(s) \times \mathbf{p}(s)| ds \quad (1)$$

$$22 \quad S = \oint |\mathbf{u}(s) \cdot \mathbf{p}(s)| ds \quad (2)$$

$$23 \quad T(\theta) = \oint |\mathbf{u}(s) \cdot \mathbf{u}(\theta)| ds \quad (3)$$

24 R and S are meaningless without a suitable choice for \mathbf{cp} . Indeed one could make R and S
25 arbitrarily large for any contour simply by choosing \mathbf{cp} to be far away. One useful choice is the

1 geometric point that minimizes the integral of squared distance between it and lines passing
 2 through and normal to the contour, which we call the *center of projection*. The center of
 3 projection can be computed as follows, where the x and y subscripts denote components of a
 4 vector:

$$5 \quad q(s) = \mathbf{p}(s) \bullet \mathbf{u}(s) \quad (4)$$

$$6 \quad g = \oint u_x^2(s) ds \oint u_y^2(s) ds - \left[\oint u_x(s) u_y(s) ds \right]^2 \quad (5)$$

$$7 \quad cp_x = \left[\oint q(s) u_x(s) ds \oint u_y^2(s) ds - \oint q(s) u_y(s) ds \oint u_x(s) u_y(s) ds \right] / g \quad (6a)$$

$$8 \quad cp_y = \left[\oint q(s) u_y(s) ds \oint u_x^2(s) ds - \oint q(s) u_x(s) ds \oint u_x(s) u_y(s) ds \right] / g \quad (6b)$$

9 Figure 3 illustrates an accidental alignment of a target to the machine vision system's pixel grid,
 10 which results in loss of information as discussed in the following paragraphs.

11 The figures of merit consider targets to be continuous boundary contours in the real plane. This
 12 is fine for analysis, but in practice images are represented as values on a discrete grid, for
 13 example 300. Unlike the real plane a grid is distinctly anisotropic—it has special directions,
 14 parallel to the grid axes and, to a lesser extent, parallel to the diagonals, which affect the
 15 information-bearing capacity of target boundaries that line up along those directions. The effect
 16 is subtle but significant, particularly for alignment methods with high intrinsic accuracy.

17 Consider the one-dimensional image intensity profile normal to a boundary contour, for example
 18 310, 320, or 340, at some point. If the boundary moves by a whole pixel amount, the profile shifts
 19 correspondingly but its shape is unchanged. For fractional pixel shifts the profile shape changes,
 20 so that the shape of the profile encodes information about sub-pixel position, although there are
 21 practical limits on how much information can be extracted at any given point. If we consider the
 22 information provided by many such profiles at many points along the boundary, however, a
 23 significant improvement in position information content can be obtained, but *only if the various*
 24 *boundary points represent statistically independent measurements.*

1 If a target boundary cuts the pixel grid 300 in a random or pseudo-random manner, for example
2 320 and 340, statistical independence is high and maximum information is conveyed. On the other
3 hand, if a portion of a boundary contour happens to line up parallel to a grid axis, for example
4 310, the intensity profile shapes at points along that portion are necessarily identical (except for
5 measurement noise), and therefore provide no mutually independent information. It is as if only
6 one point along the boundary portion is considered instead of many. Such an accidental
7 alignment of target 310 to grid 300, and the resulting loss of information, is called a *grid*
8 *degeneracy*. Grid degeneracy in principle affects any alignment method, whether intensity
9 profiles are examined directly or only indirectly, but is most noticeable when the alignment
10 method's intrinsic accuracy is very high.

11 The loss of accuracy associated with grid degeneracy is not always apparent. Some alignment
12 methods do not have sufficient intrinsic accuracy for the effect to be measurable. In other cases,
13 a method may use a model of intensity profile shape that happens to match well the behavior of
14 specific images being tested. This may mask the grid degeneracy for those images, but since
15 profile behavior is not reliable to high precision such a result is unreliable in practice.

16 Targets such as crosses, for example 310 and 320, and rectangles suffer most seriously from grid
17 degeneracies because the entire boundary can be aligned simultaneously with the grid axes, as in
18 310. The worst case for such figures occurs when the target dimensions are close to a whole
19 number of pixels, because no independent measurements are made anywhere along the entire
20 boundary. If the dimensions are not close to a whole number of pixels, then at least some
21 independent information can be obtained from different edges of the target (e.g. the left and right
22 side of a rectangle).

23 Susceptibility to grid degeneracy is an important accuracy criterion in the engineering of an
24 alignment target. A figure of merit GD one can use is the fraction of the target's boundary
25 contours that can align with the pixel grid simultaneously. For rectangles and crosses GD is 1.0,
26 the worst case. For circles 340 it is 0, the best case. Note that this figure of merit doesn't consider
27 the effect of whole pixel dimensions.

28 Figure 4 illustrates the alignment speed criteria used, as further discussed in the following
29 paragraphs.

1 For most practical alignment methods, the most important effect on speed of the engineering of a
2 target is the extent to which the target can be identified unambiguously by its coarse features.
3 This criterion is hard to quantify meaningfully, and so is more a matter of judgement. Fine detail
4 itself is not a problem, but for best alignment speed it should be used to enhance accuracy and
5 not to identify the target.

6 For example the thin cross 400 fails to satisfy this criterion, and is a poor choice for an alignment
7 target. The cross 400 has only fine detail, no coarse features that can be used to estimate its
8 location in a coarse resolution examination of the image.

9 Unambiguous identity based on coarse features applies to each of the degrees of freedom.
10 Consider for example the target 420. The x-y position of this target is unambiguous when looking
11 at its coarsest feature, the overall square shape. Its orientation, on the other hand, has 90°
12 ambiguities until one looks at its finest feature 430. Although one should expect an alignment
13 method to be able to determine the rotation of this target over a 0 - 360° range, the alignment
14 time will be longer because fine detail must be examined in order to do so. Note that target 400
15 fails the speed criterion in all degrees of freedom.

16 Figure 5 illustrates the alignment yield criteria used, as further discussed in the following
17 paragraphs.

18 In general the most significant factor affecting alignment yield is image degradation—if images
19 were always perfect copies of the trained pattern, just about any alignment method would give
20 100% yield. Although image degradation may be intrinsic to the manufacturing process and
21 difficult to control, there are some target engineering criteria that can help.

22 One form of degradation is where the target fails to survive the manufacturing process
23 reasonably intact. For the most part survivability is an application-specific issue, but we can
24 reasonably assume in general that coarse features will survive better than fine features. This is
25 consistent with and perhaps more restrictive than the speed criterion, suggesting that at least for a
26 UAT very fine features should be avoided.

27 The effects of degradation are mitigated when the target's shape is as dissimilar as possible both
28 from other patterns in the field of view and from translated, rotated, or sized versions of the

1 target itself (i.e., low auto-correlation secondary peak in all degrees of freedom). If the target is
2 too similar in appearance to other patterns or itself, image degradation can wipe out differences
3 and cause failures to find or misalignments. For example the target 420 is very similar to itself in
4 90° rotations. If image quality degrades significantly as in 500, the small difference 510 between
5 the correct and false orientations can be hard to detect reliably.

6 Another example of self-similarity is a triangle in the size degree of freedom. Fully two-thirds of
7 the boundary of a triangle will match a larger version of the same shape.

8 Similarity to other patterns in the field of view is of course application-specific, but again general
9 guidelines are possible. Parallel and orthogonal features, and simple geometric shapes, are
10 common in manufactured goods and are therefore best avoided in an alignment target intended to
11 be universal.

12 Consider for example a portion of a printed circuit board 530 containing circuit traces 550 and an
13 alignment target 540. Note that the traces in area 560 match 75% of the target 540. As long as
14 image quality is near perfect the false target 560 can be distinguished from the real target 540.
15 Under realistic conditions of image degradation, however, the similarity of area 560 to target 540
16 will result in a non-zero error rate.

17 Figure 6 illustrates a target defined by a set of algebraic formulas to satisfy the ease of use
18 criteria, as further discussed in the following paragraphs.

19 An alignment target should be easy to render, train, and analyze. Training includes both
20 producing suitable shape information for an alignment method and selecting a known reference
21 point on the target for reporting alignment position. Analysis includes computing the figures of
22 merit.

23 Since all alignment methods in common use can be trained from images, and since there is no
24 other generally accepted format for providing shape information, a high quality pixel-grid
25 rendering of a target is considered necessary and sufficient for training a target. Realistically
26 shaded edges are considered essential for providing accurate shape information, so for example
27 targets generated by the typical “paint” programs are unacceptable.

1 Targets drawn by hand using painting or drawing programs, or acquired from a physical device
2 such as a video camera, are difficult to analyze, usually do not allow precise selection of a
3 reference point, and may be difficult to render in whatever substrate will contain the target in the
4 alignment application. Such targets are not suitable for use as a UAT.

5 The objectives are met by targets that are defined algebraically in the real plane. In a preferred
6 embodiment, a target is defined by a real-valued function of real-valued coordinates $f(x, y)$ such
7 that f gives at each point (x, y) the distance and direction (+ or -) to the nearest boundary
8 contour. The contours are defined by $f(x, y) = 0$, the points inside the contours as $f(x, y) > 0$, and
9 outside as $f(x, y) < 0$.

10 For computational simplicity the method does not require that $f(x, y)$ give precise distance, only
11 that the value is reasonably close. This simplification has been found useful for targets best
12 defined in polar coordinates, such as the fan configurations, which are derived from the
13 function's Cartesian arguments.

14 For example target 600 is a square of radius 610 r , and with corners rounded to radius 620 c . The
15 target is defined according to a preferred embodiment by defining the function f using the set of
16 algebraic formulas 630.

17 A set of algebraic formulas defining a target provides a universal and unambiguous definition,
18 which can serve as the basis for a computer program that can render the target for various
19 purposes:

20 Training The rendering program can produce a bitmap image that can be fed
21 directly to an alignment method for training. The target reference point is
22 also defined algebraically. As a result, training is fully automatic, with no
23 human involvement and no need to even acquire a training image from a
24 camera.

25 Reproduction The rendering program can be used to reproduce the target on the substrate
26 used in the alignment application. Source code for the program can be
27 delivered to manufacturers of CAD systems, laser engravers, and the like
28 for use in their products. Source code is absolutely precise and

1 unambiguous, can be independently tested and certified, can be distributed
2 by email or published on Web sites, and is ultimately what just about any
3 mechanical rendering device will need. Of course what makes a target
4 easy to render is somewhat application-specific. For example, some
5 processes may be able to render only horizontal and vertical features.
6 Nevertheless algebraically-defined targets with appropriate software are
7 flexible enough to handle most application-specific requirements.

8 Documentation The rendering program can produce pictures of the target for written
9 documentation, as was done in the production of this patent specification.

10 Analysis The rendering program is used to drive analysis software that computes
11 figures of merit by numerical integration. Since the rendering program
12 itself drives the numerical integration, the results are guaranteed to
13 correspond to the target as rendered.

14 Testing The target is defined on the real plane and the rendering program
15 approximates this using high-precision floating point calculations. As a
16 result the target can be translated, rotated, and sized to effectively arbitrary
17 precision prior to rendering as a discrete image. Various edge, lens, and
18 noise models can be applied in the floating point domain. The resulting
19 images can be used for fully automated accuracy, speed, and yield testing.

20 Figure 7 illustrates a preferred rendering method according to the invention. This method for
21 algebraic rendering and analysis of targets has been found by experience to be remarkably
22 simple, as measured in number of lines of code needed, and in general, as measured by the
23 variety of targets that can be generated. Following the preferred method, a target is defined by a
24 real-valued function of real-valued coordinates $f(x, y)$ as described above and illustrated by
25 example in figure 6.

26 A scan pattern generation step 700 is used to generate a sequence of real-valued coordinates (x, y)
27 as appropriate for the rendering to be made. For example, to render a bitmap image the

1 coordinates would correspond to the centers of the image pixels. For guiding a laser engraver,
2 the coordinates would correspond to beam position.

3 An optional lens model step 710 is used to apply a coordinate transform to model the imaging
4 geometry, which maps the scan pattern coordinates (x, y) to new coordinates (x', y') . Typically
5 an identity transform is used, but translation, rotation, size, aspect ratio, skew, perspective, and
6 lens distortion transforms can be applied. These transforms are of particular value for alignment
7 method accuracy testing, because the amount of transformation is precisely known.

8 A computational step 720 is used to compute the shape-defining function $f(x', y')$, which results
9 in a real-values estimate of distance to the nearest boundary contour.

10 An edge model step 730 is used to apply a real-valued brightness transform that models edge
11 sharpness, focus, video gain, noise, and other physical processes.

12 A digitizer model step 740 is used to convert the brightness values I as appropriate for the final
13 rendering, for example 8-bit integers for monochrome bitmap images 750.

14 The only target-specific software needed is the code to implement the function $f(x, y)$ in step 720.
15 The above example target of figure 6 requires around 20 lines of code in the Visual Basic
16 programming language; the complex UAT shown in figure 15 requires around 200.

17 Target-independent software follows the target contours defined by $f(x, y) = 0$ and performs the
18 numerical integration needed to compute the figures of merit. A small amount of target-specific
19 software to provide a list of contour starting points is used. The contour following software can
20 also generate a line-drawing of the target if such is needed.

21 A system for target generation follows an object-oriented approach with targets implemented by
22 polymorphic objects and used by target-independent rendering and analysis software. Such a
23 system would include a GUI for parameter selection and display of images and other results.

24 The above description relies on hard-coded implementations of $f(x, y)$, which results in high
25 rendering speed and simple software design. It is also possible to implement a "universal"
26 function f_u that uses a general-purpose shape description in the form of lines and arcs, such as a

1 CAD description. With such a method creating a new target shape would be simpler and require
 2 no programming, but a larger one-time software effort would be needed to implement f_u and
 3 rendering and analysis would be slower. A complete system for target generation would include
 4 both universal and specialized functions.

5 Figure 8 shows an edge model used in a preferred embodiment of rendering step 730. The figure
 6 shows the f coordinate axis 800, which represents distance (+ or -) to the nearest boundary
 7 contour, and the brightness coordinate axis 820. In a preferred embodiment, a sigmoid function
 8 840 is used:

$$9 \quad I = \text{background} + \frac{\text{contrast}}{1 + e^{-\theta \sigma}} \quad (7)$$

10 This edge model is easy and fast to compute, produces excellent anti-aliased edges, and allows
 11 precise control of edge sharpness using the parameter σ .

12 Figure 9 illustrates some common alignment targets that are used as a reference point in the
 13 engineering of novel, high performance targets according to the invention. For clarity we start
 14 with simple geometric shapes and build in small steps towards the goal. It should be clear that
 15 the resulting UAT is not unique, and that many variations, both minor and substantial, would be
 16 consistent with the spirit of the procedure and may be more suitable for specific applications.

17 Speed and yield criteria are based on an analysis of the degree of similarity between the target
 18 and other patterns. Similarity is somewhat dependent on the alignment method in use,
 19 particularly on whether the method is primarily based on areas, or on boundaries. While
 20 different methods may disagree on the degree of similarity between two patterns, in general there
 21 is necessarily much more agreement than disagreement.

22 In the following development, similarity is considered based on boundary matching, not area
 23 matching. While the analysis is therefore more directly applicable to boundary-based methods, it
 24 is still largely method independent since boundary shape determines area shape. The UAT that
 25 results is a superb target for use with just about any general-purpose method.

26 Consider first a circle 900 of radius r . The figures of merit are given in table 1.

1

Table 1. Circle				
<i>R</i>	<i>S</i>	worst $T(\theta)$	best $T(\theta)$	<i>GD</i>
0	$6.28 r^2$	$4.0 r$	$4.0 r$	0

2 As can be seen there is no information for measuring rotation and no grid degeneracy. The scale
 3 figure of merit is pretty good but the translation figure could be better. If we ignore the rotation
 4 degree of freedom, speed and yield criteria are satisfied as long as no similar shapes appear in the
 5 field of view. Circles are common shapes, however. Of course we don't need all of this analysis
 6 to know that a circle is a poor choices for a UAT, but the numbers give a point of comparison
 7 when considering other shapes.

8 Now consider a square 920 of radius r , whose figures of merit are given in table 2.

9

Table 2. Square				
<i>R</i>	<i>S</i>	worst $T(\theta)$	best $T(\theta)$	<i>GD</i>
$4.0 r^2$	$8.0 r^2$	$4.0 r @ 0^\circ$	$5.66 r @ 45^\circ$	1.0

10 All degrees of freedom can be measured, although twice as much information is available to
 11 measure size as rotation (these figures can be compared directly, but cannot meaningfully be
 12 compared with the translation figures). A factor of $\sqrt{2}$ imbalance also exists between the best and
 13 worst translation directions. These imbalances are not serious, but neither are they ideal. Grid
 14 degeneracy is worst case. Speed is good, but the square will match itself perfectly at 90° rotation
 15 increments, and 50% of its boundary will match a corner or a much larger square. These self-
 16 similarities, combined with the fact that it is a common shape, fail to satisfy our yield criteria.

17 Next consider a cross 940 of radius (half-width) r and arm radius (half-thickness) a , whose
 18 figures are given in table 3.

19

Table 3. Cross				
R	S	worst $T(\theta)$	best $T(\theta)$	GD
$4.0 r^2$	$8.0 a (2r - a)$	$4.0 r @ 0^\circ$	$5.66 r @ 45^\circ$	1.0

1 Interestingly, except for the size degree of freedom the figures are identical to those of a square.
 2 This makes sense since the boundaries of a cross are identical to those of a square in perimeter
 3 length and orientation; a cross is just a square with its corners folded in. Considering just these
 4 figures of merit, then, a cross is never better than a square, and always worse in size
 5 measurement capability.

6 Other factors may come into play, however. Recall that GD does not capture the ability to
 7 mitigate the effects of grid degeneracy by choosing the dimensions of the target to be non-whole-
 8 pixel amounts. With a square there are only two independent edges potentially providing
 9 translation information (it's not 4 because there are 2 translation degrees of freedom). With a
 10 cross with sufficiently thick arms, we get 4 edges for each translation degree of freedom,
 11 assuming that none of the 6 possible pairs of the 4 edges are separated by a whole number of
 12 pixels. Thus a cross can be made less susceptible to grid degeneracy than a square, but only by
 13 careful engineering.

14 Another factor that might favor a cross is that in some applications scene real estate may be too
 15 limited to allow using a square, but a cross can be squeezed in between other portions of the
 16 scene.

17 Thin crosses fail to meet the speed criteria due to lack of coarse features, and all crosses suffer
 18 from the same yield concerns as squares.

19 Since crosses are commonly used as alignment targets in spite of these problems, the above
 20 analysis is summarized in the following guidelines for their use:

- 21 1. Make the arms as thick as possible
- 22 2. Make the edge-to-edge dimensions not be whole numbers of pixels.

1 3. Round the corners if possible to further reduce grid degeneracy.

2 Figure 10 illustrates a starting shape according to a preferred embodiment of the target
3 engineering method of the invention. This starting point and the shapes derived from it have
4 proven to be productive in engineering superb alignment targets. The shapes are based on a basic
5 shape-type that we call a *fan*. Other starting points and refinement decisions are possible, and no
6 implication is made that the fan shapes are best. They are the best we've developed to date,
7 however, and the principles used to engineer them can be applied in exploring other
8 configurations.

9 The *primitive fan* shape (primfan) is shown in figure 10. It consists of 4 *blades* 1000 connected to
10 a central circular *hub* 1010. All inner and outer corners, for example 1020, are rounded to avoid
11 sharp corners that are hard to fabricate in many substrates, and often fail to survive harsh
12 environments

13 All of the fan shapes that are considered herein are defined by straight-line segments in polar
14 coordinates. The vertices where these segments intersect are rounded by segments of circles, also
15 in polar coordinates for simplicity. Thus the actual shape of the rounded corners in the final
16 Cartesian rendering is complex, but for the small radii used they look just fine. A plane figure
17 constructed from line segments in polar coordinates, with optionally rounded vertices, is called a
18 generalized polar polygon.

19 In figure 10 the primfan is also drawn in a polar coordinate system 1050. The blades 1060 and hub
20 1070 can be seen.

21 Here and below the radius of the fan is r . The parameters defining this particular primfan are
22 given in table 4, and the figures of merit in table 5.

23

Table 4. Primfan parameters	
Fan radius	r
hub radius	0.2 r
blade width 1035	45°
blade gap width 1030	45°
corner radius	0.047 r

1

Table 5. Primfan				
<i>R</i>	<i>S</i>	worst $T(\theta)$	best $T(\theta)$	<i>GD</i>
$3.84 r^2$	$3.27 r^2$	$6.11 r @ 22.5^\circ$	$6.50 r @ 0^\circ$	0.31

2 The worst case translation figure for the fan is better than the best case for circles, squares, and
 3 crosses of equal radius, and 53% better than the worst case for those targets. This is because
 4 more perimeter is packed into the same area, and better balanced in orientation. *GD* is pretty
 5 good at 0.31, corresponding to 4 of the 8 blade edges simultaneously subjected to grid
 6 degeneracy. The figures for rotation and size are a little small and somewhat imbalanced, but not
 7 bad either.

8 Speed is excellent due to unambiguous coarse features. There is of course the 90° symmetry, and
 9 self-similarity in size is also too large due to the fact that the radial features, which comprise
 10 63% of the total perimeter, match perfectly as size changes. The fan is not a common shape,
 11 however, and is not likely to be confused with other patterns in the field of view.

12 Figure 11 shows the first refinement in the fan series. Holes 1100 are added in the blades,
 13 resulting in the simple fan shape 1110 (*simfan*), with hole parameters given in table 6 and figures
 14 of merit in table 7. The simfan is also drawn in polar coordinates 1120.

15

Table 6. Simfan hole parameters	
hole inner radius	$0.5 r$
hole outer radius	$0.8 r$
hole width	15°

1 The additional perimeter improves all of the figures of merit. R and S are somewhat more
 2 imbalanced, though, as the defined boundary squeezes more information out of the rotation
 3 degree of freedom than size.

4

Table 7. Simfan				
R	S	worst $T(\theta)$	best $T(\theta)$	GD
$5.40 r^2$	$4.19 r^2$	$8.20 r @ 45^\circ$	$8.83 r @ 0^\circ$	0.24

5 Speed is still expected to be excellent. The rotation 90° ambiguity hasn't been addressed, but the
 6 size self-similarities are reduced because the holes won't match at the wrong size.

7 Figure 12 illustrates the next refinement step. One advantage of the fan configuration is that
 8 since it is composed of radial and circular features, rotation and size performance can be
 9 controlled independently. With a simple change we can bring up S without affecting R . The
 10 result 1200 is called a *balanced fan* (balfan), also shown in polar coordinates 1220. The defining
 11 parameters given in table 8, and the figures of merit in table 9.

12

Table 8. Balfan parameters	
Fan radius	r
hub radius	$0.2 r$
blade width 1235	56°
blade gap width 1230	34°
corner radius	$0.047 r$

hole inner radius	$0.5 r$
hole outer radius	$0.8 r$
hole width	18.67°

1 Note that all we've done is widen the blades to 56° , and widen the holes proportionally (the
 2 holes are $1/3^{\text{rd}}$ the blade width).

3

Table 9. Balfan				
R	S	worst $T(\theta)$	best $T(\theta)$	GD
$5.40 r^2$	$5.15 r^2$	$8.92 r @ 45^\circ$	$9.31 r @ 0^\circ$	0.22

4 Note that the figures of merit are fairly well balanced, hence the name of the fan, and
 5 numerically better than simfan and much better than any of the simple geometric shapes we
 6 considered above. Speed and yield are neither better nor worse than simfan.

7 Figure 13 illustrates the next refinement, which is to fix the 90° ambiguity. This is done by
 8 making each blade and gap a different size. The resulting shape 1300 is called a *balanced*
 9 *asymmetric fan* (basfan), also shown in polar coordinates 1350. This basfan has the same total
 10 blade and gap width as the balfan, so that the figures of merit that we worked to balance are not
 11 significantly changed. As before the holes are kept at $1/3^{\text{rd}}$ the blade width.

12 The parameters describing the blades are given in tables 10a and 10b, with figures of merit in
 13 table 11. All of the radial and rounding parameters are as for previous fans.

14

Table 10a. Basfan parameters		
Blade	Starting Azimuth	Width
1310, 1360	0°	38°
1320, 1370	57°	50°
1330, 1380	146°	74°
1340, 1390	269°	62°

1
2

Table 11. Basfan				
<i>R</i>	<i>S</i>	worst $T(\theta)$	best $T(\theta)$	<i>GD</i>
5.42 r^2	5.21 r^2	8.64 $r @ 38^\circ$	9.47 $r @ 134^\circ$	0.11

3 Note, as expected, that *R* and *S* are not significantly changed from balfan. The worst case $T(\theta)$
 4 has dropped slightly, with the best case rising, which is not surprising. *GD* has gone down by
 5 half, since now no more than two blade edges can suffer simultaneously from grid degeneracy.
 6 Note that with 8 blade edges and 28 pairs it is essentially impossible to reduce this to just one
 7 edge, since the test for simultaneous grid alignment has to allow for approximate alignment.

8 Although we've eliminated the serious 90° ambiguity, there is still some rotation and size self-
 9 similarity in the basfan. Considering rotation, any blade edge will match any other at some angle,
 10 and any point on the circumference will match any other point on the circumference. The
 11 asymmetry of the basfan reduces but does not eliminate these matches, which will result in
 12 secondary auto-correlation peaks. In size, the blade edges will match over a wide range of sizes,
 13 although the radial edges of the holes will not.

14 In summary the basfan is good on all criteria of speed, accuracy, and yield, but there is still room
 15 for improvement.

1 Figure 14 illustrates the next refinement. The radial features of previous fan configurations cause
 2 both grid degeneracy and self-similarity in size. A simple change to the formulas defining the fan
 3 in polar coordinates allows us to generate radial features that are sections of spiral curves,
 4 resulting in shape 1400. This is the first of two steps leading towards our final fan configuration,
 5 the *balanced radically asymmetric fan* (bradfan).

6 In polar coordinates, the bradfan after the first modification 1450 can be compared with the
 7 basfan 1350. Considering a particular blade 1404, the dotted lines show the blade edges before the
 8 change (basfan), and the solid lines show the blade and hole for bradfan 1400, 1450. As can be
 9 seen, the outer edge of the blade has not moved, but where the blade connects with the hub has
 10 been moved by an amount 1406 called *skew*.

11 The blade parameters for the bradfan so far are given in table 12.

12

Table 12. Bradfan parameters, step 1			
Blade	Starting Azimuth	Width	Skew
1410, 1460	0°	38°	11°
1420, 1470	57°	50°	-11°
1430, 1480	146°	74°	-22°
1440, 1490	269°	62°	22°

13 This simple change eliminates all straight radial features in the final rendering, which eliminates
 14 grid degeneracy and size self-similarity. The skew parameters are chosen to be different for each
 15 blade, so that blade edges will not match those of other blades under rotation. This reduces some,
 16 but not most, of the rotation self-similarity. All figures of merit improve over basfan, as can be
 17 seen in table 13.

18

Table 13. Bradfan step 1				
<i>R</i>	<i>S</i>	worst $T(\theta)$	best $T(\theta)$	<i>GD</i>
$5.88 r^2$	$5.71 r^2$	$8.82 r @ 37^\circ$	$9.51 r @ 137^\circ$	0

1 Figure 15 illustrates the second and final step in making the bradfan, which eliminates the final
 2 rotation self-similarity. This is done by making the outer blade edges also spiral sections, instead
 3 of circular. The final bradfan 1500 is shown, also drawn in polar coordinates 1550. A particular
 4 bradfan blade 1504 in polar coordinates shows both the skew parameter 1506 and a new spiral
 5 parameter 1508. The complete blade parameters are given in table 14, and the final figures of
 6 merit in table 15.

7 Unlike previous fan parameters, which were chosen by hand, these parameters were obtained by
 8 an automated search of the 41,472 distinct arrangements of the 16 blade parameters, followed by
 9 a manual examination of the 100 highest ranking permutations.

10

Table 14. Final bradfan blade parameters				
Blade	Starting Azimuth	Width	Skew	Spiral
1510, 1560	0°	62°	22°	$0.09 r$
1520, 1570	81°	74°	-11°	$0.03 r$
1530, 1580	184°	50°	-22°	$-0.09 r$
1540, 1590	283°	38°	11°	$-0.03 r$

11 The hub, hole, and rounding parameters are as before. Note that the spiral parameters are
 12 different for each blade to avoid rotation self-similarity.

13

Table 15. Final bradfan				
R	S	worst $T(\theta)$	best $T(\theta)$	GD
$6.12 r^2$	$6.12 r^2$	$9.06 r @ 137^\circ$	$9.50 r @ 68^\circ$	0

1 The worst case translation figure of merit is over $9 r$, which is 225% better than the worst case
 2 for a cross, and translation is well balanced over all angles. The automated search has given us
 3 superb and perfectly balanced R and S values. R is 53% better than a cross or square at the same
 4 radius, and S is just about what a complete circle would be.

5 The bradfan has no fine features and so should be fast to find and survive most manufacturing
 6 processes well. It has excellent figures of merit in all degrees of freedom and no grid degeneracy.
 7 It has no significant self-similarities in any degree of freedom, and looks nothing like any shape
 8 in common use. The bradfan is an ideal universal alignment target.

9 Figure 16 illustrates an apparatus for locating objects using cooperative targets. An object 1600 is
 10 located somewhere in space relative to some object or device intended to grip, operate on, dock
 11 with, avoid, or otherwise interact with the object 1600, such as the illustrated robot gripper 1660.
 12 The object 1600 contains a cooperative target 1610. A camera or other suitable image forming
 13 device 1620 is located in a known position and attitude in space relative to the gripper 1660, and
 14 such that the cooperative target 1610 appears in the field of view of the camera 1620.

15 The object's location relative to the gripper 1660 and camera 1620 may be uncertain in various
 16 degrees of freedom, including translation degrees of freedom 1680 and 1682, orientation degree of
 17 freedom 1684, and distance degree of freedom 1686.

18 The camera 1620 is connected to a machine vision system 1630, which produces as part of its
 19 operation, using means well-known in the art, a digital image 1635. The digital image 1635 will
 20 contain an image of the cooperative target 1610. The location of the target in the image will be
 21 uncertain in various degrees of freedom, such as translation, orientation, and size, that correspond
 22 to the uncertainties in location of the object 1600 in space, for example 1680, 1682, 1684, and 1686,
 23 where said correspondence is described by well-known mathematical formulas.

1 The machine vision system 1630 contains an alignment algorithm 1640 that reads and analyzes the
2 digital image 1635 to determine the location of the target in the digital image. Using this
3 information the machine vision system 1630 computes the location in space of the target 1610
4 using well-known formulas, and communicates this information to some device, such as robot
5 controller 1650, for use in gripping, operating on, docking with, avoiding, or otherwise interacting
6 with the object 1600.

7 In one embodiment of the invention, the alignment algorithm 1640 is capable of aligning non-
8 translation degrees of freedom such as orientation and size, and the cooperative target 1610
9 conveys sufficient information in such degrees of freedom to enable the alignment algorithm
10 1640 to make such measurements. In another embodiment of the invention, targets are used that
11 have at least one of the following attributes:

- 12 • They satisfy the invention's evaluation criteria.
- 13 • They result from the use of the invention's design method.
- 14 • They have no significant rotational symmetry
- 15 • They have no significant orientation or size self-similarity
- 16 • They are not primarily composed of circles, circular arcs, straight lines, or right
17 angles.

18 In a preferred embodiment, a universal alignment target such as 1500 is used in conjunction with
19 an alignment algorithm 1640 capable of aligning non-translation degrees of freedom, such as one
20 of the many products available today offering such capabilities.

21 Other modifications and implementations will occur to those skilled in the art without
22 departing from the spirit and the scope of the invention as claimed. Accordingly, the above
23 description is not intended to limit the invention except as indicated in the following claims.

24

25 What is claimed is:

26

- 1 1. A method for locating an object, the method comprising:
- 2 Rendering an alignment target on the object, the alignment target being adapted to be
- 3 substantially rotationally asymmetric and substantially size self-dissimilar; and
- 4 Searching for the alignment target so as to provide the pose of the object.

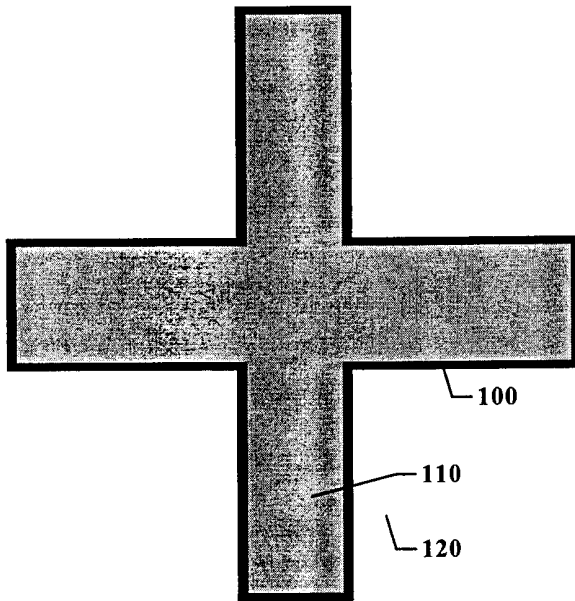

Figure 1—A common cooperative target

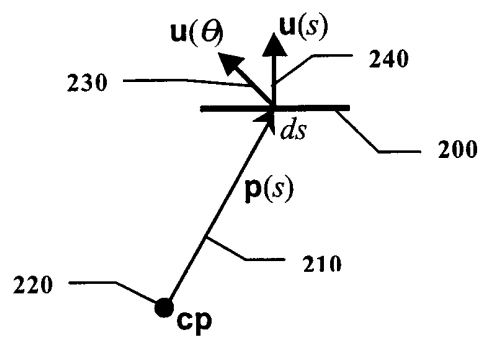

Figure 2. Element of figure of merit

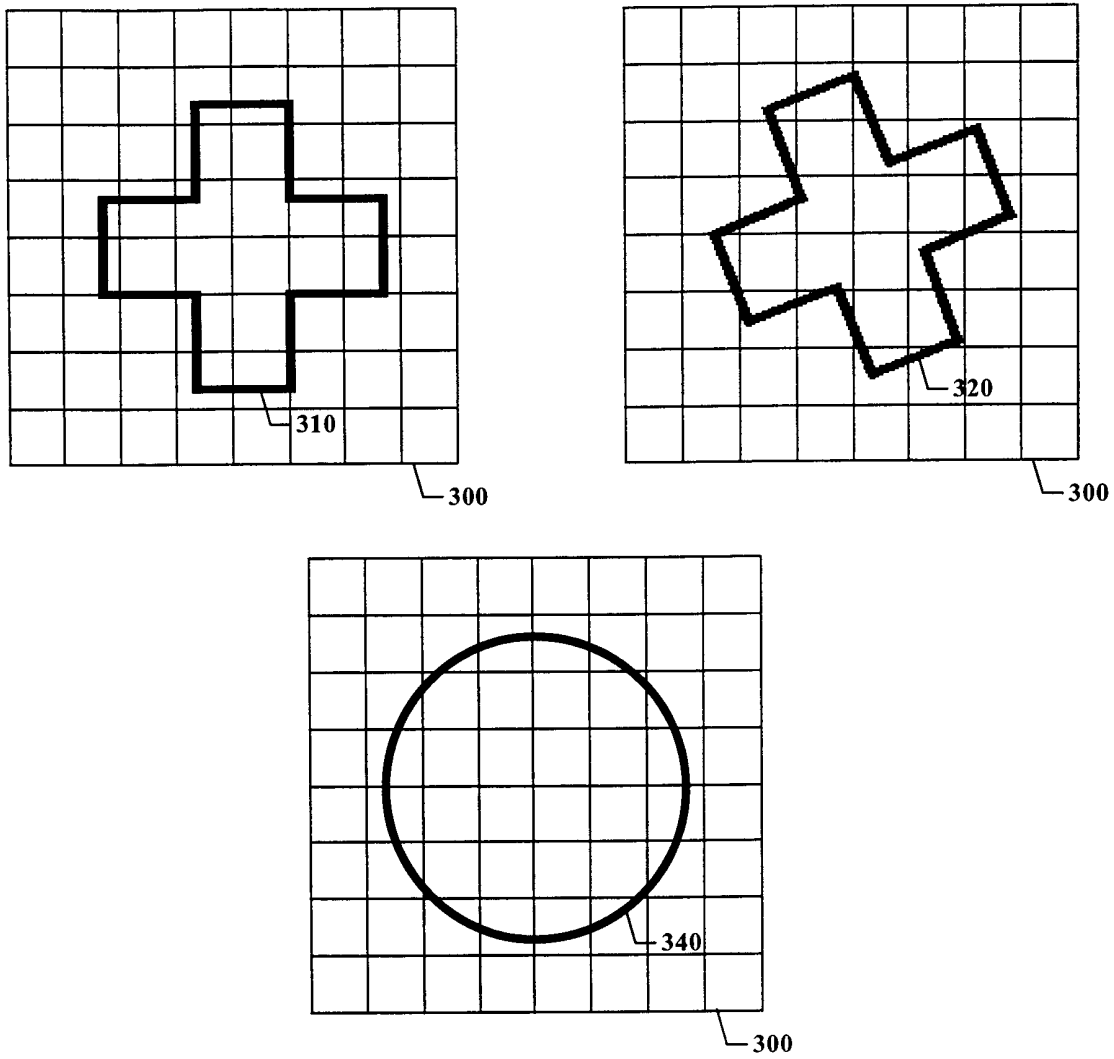

Figure 3—Illustration of grid degeneracy

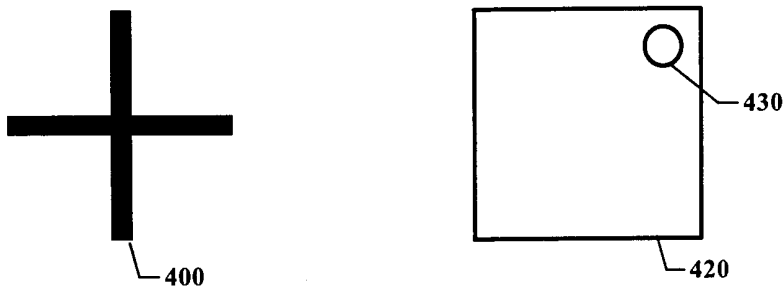

Figure 4—Illustration of speed criteria

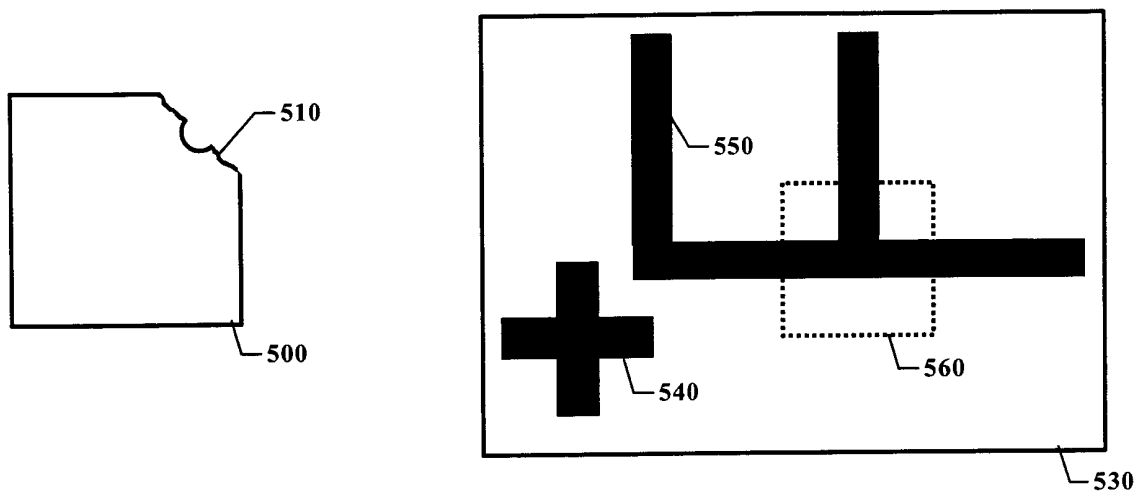

Figure 5—Illustration of yield criteria

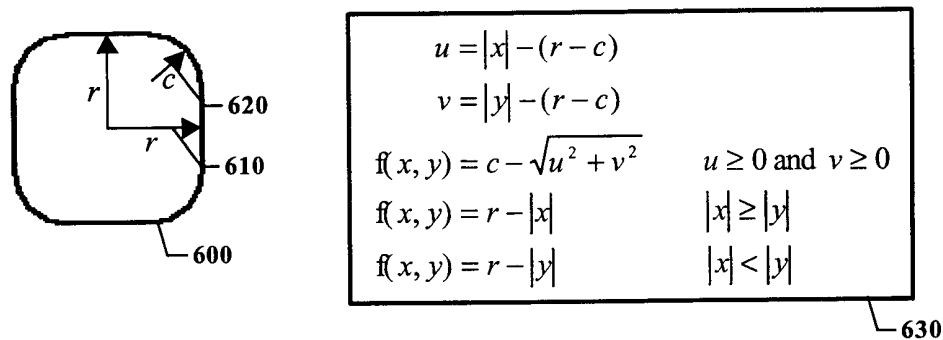

Figure 6—Targets defined algebraically are easy to use

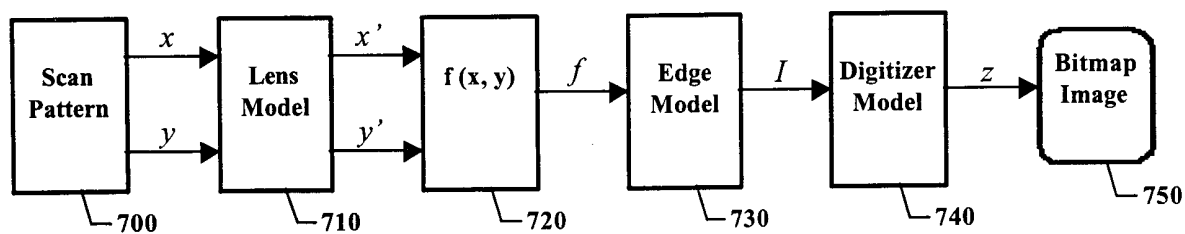

Figure 7—Target rendering method

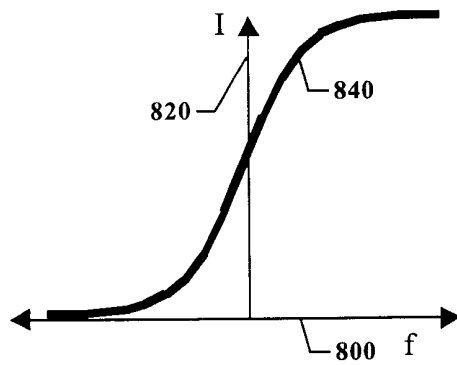

Figure 8—Intensity profile function used in target rendering method

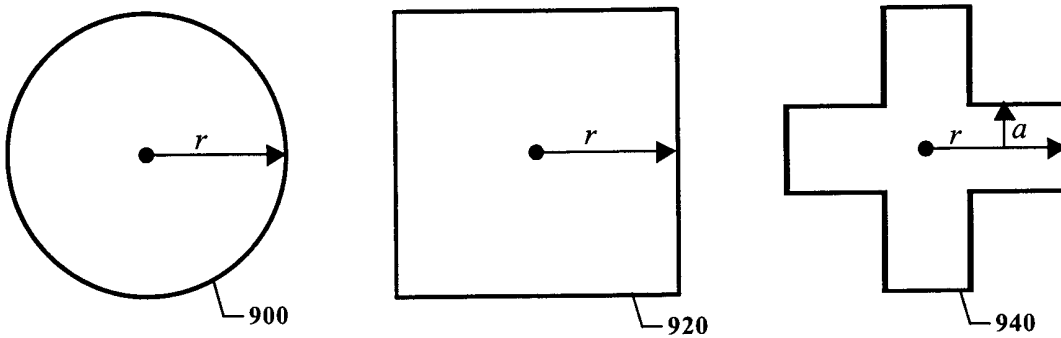

Figure 9—Common alignment targets

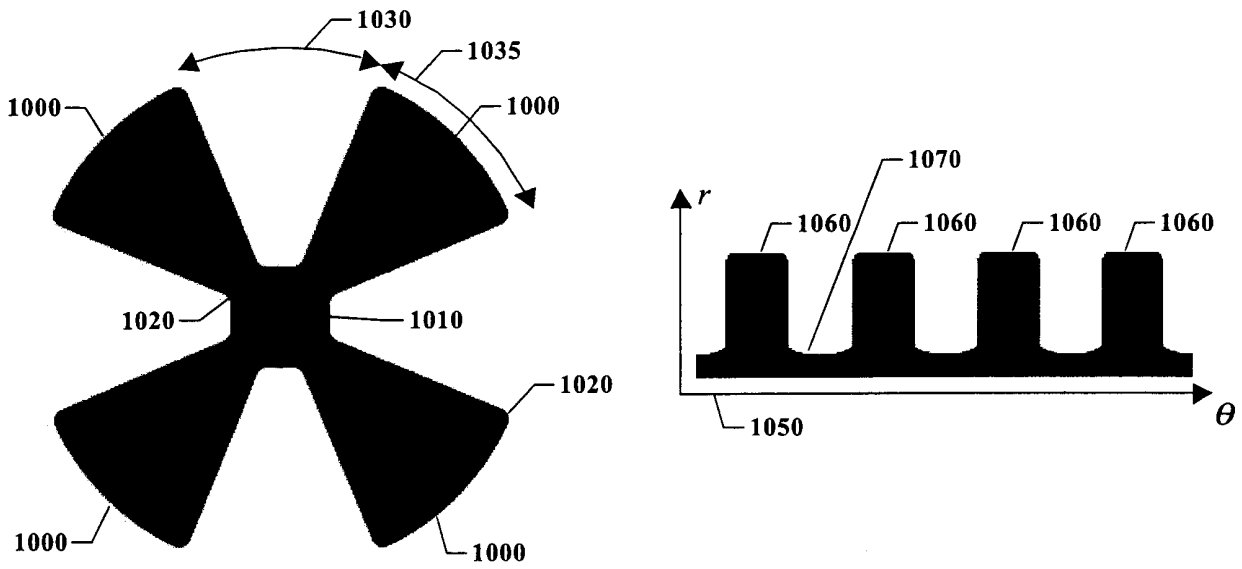

Figure 10—Primitive fan

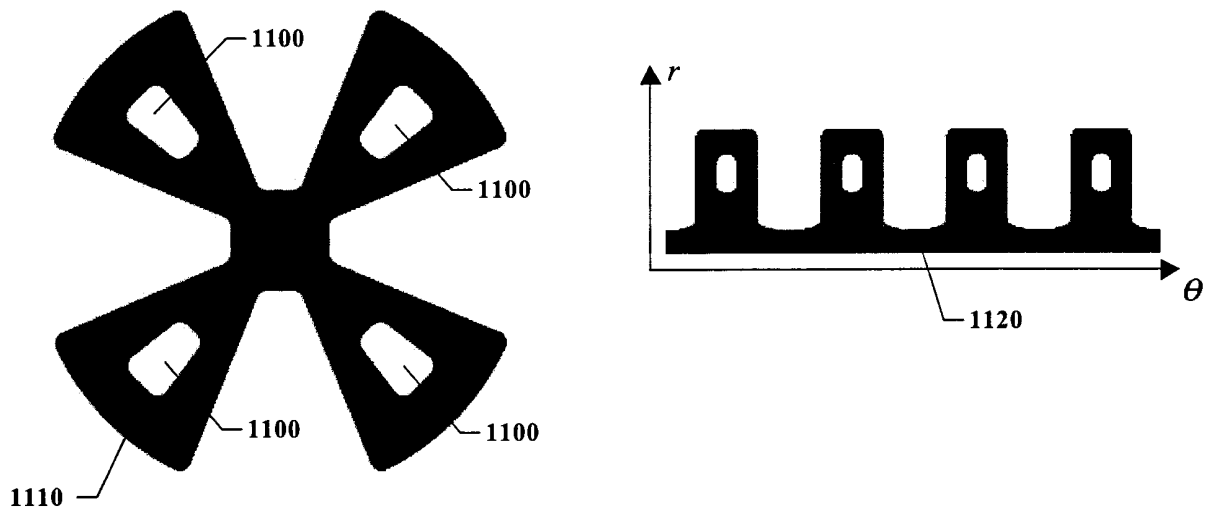

Figure 11—Simple fan

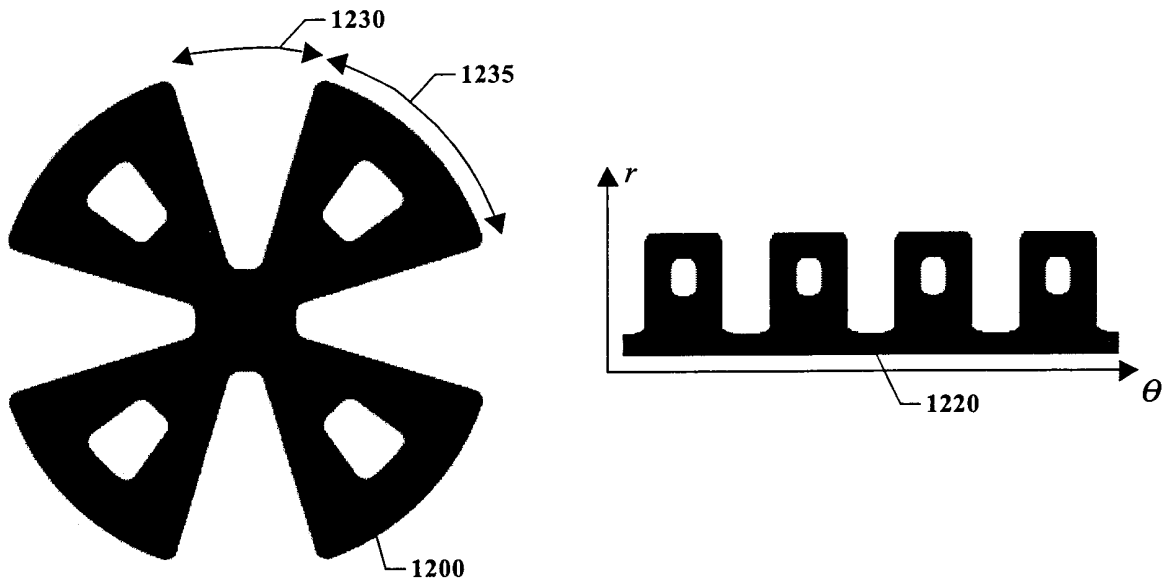

Figure 12—Balanced fan

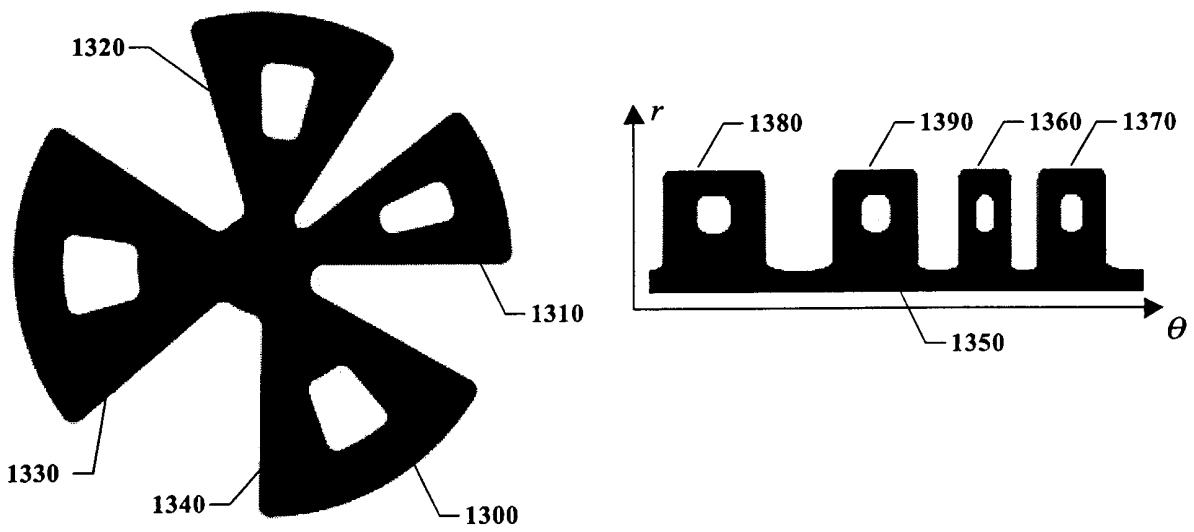

Figure 13—Balanced asymmetric fan

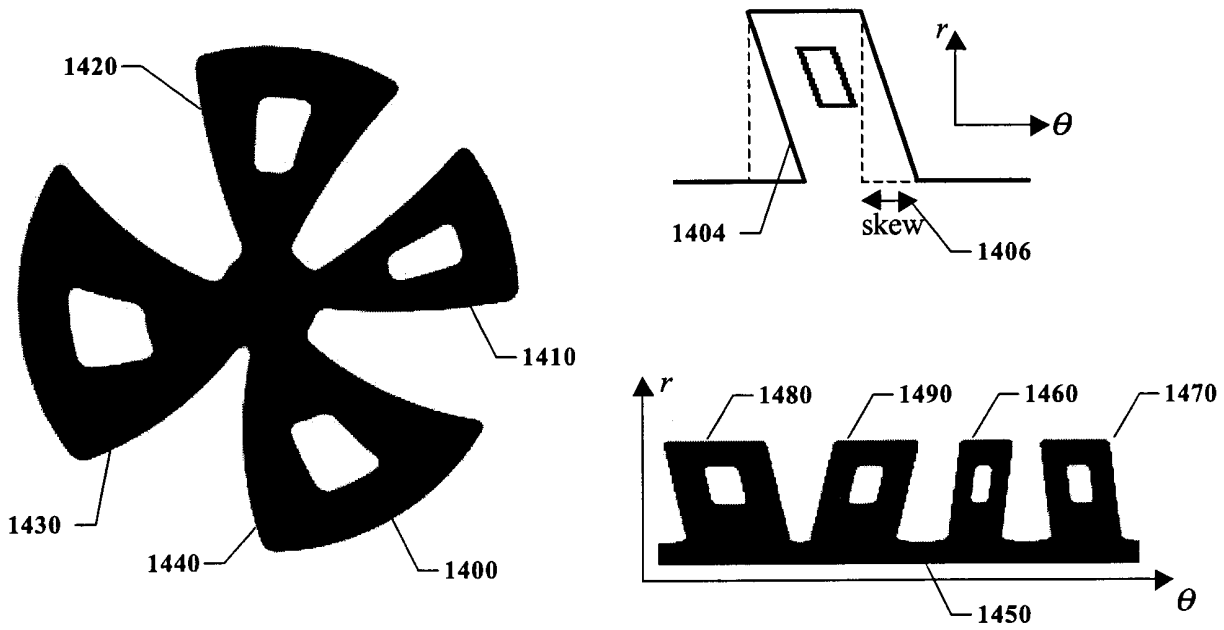

Figure 14—Balanced radically asymmetric fan, step 1

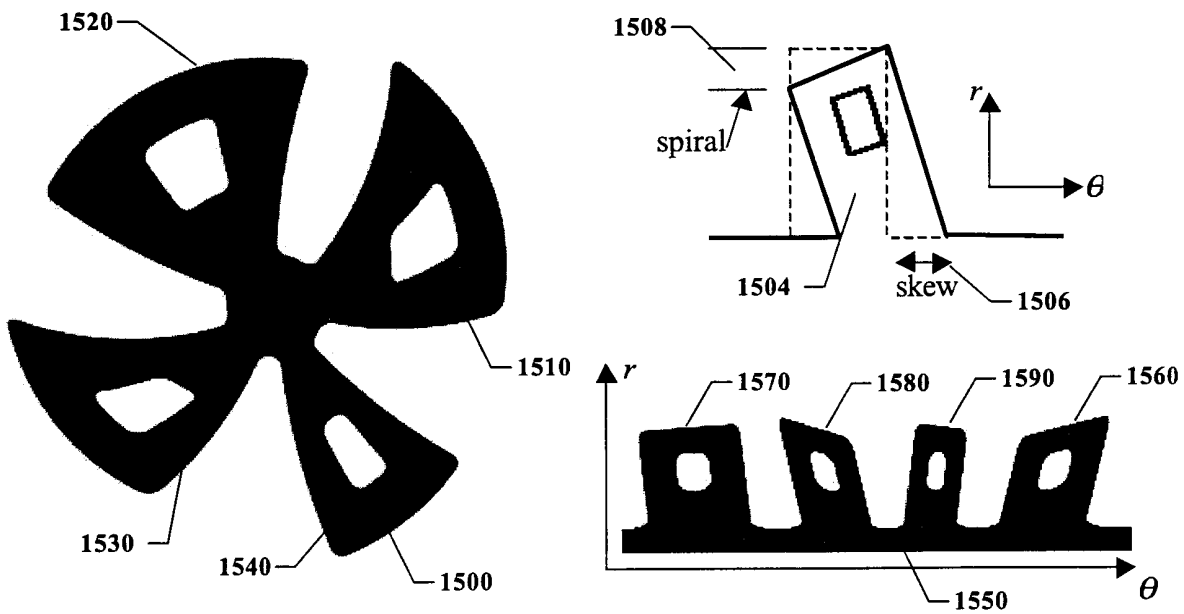

Figure 15—Balanced radically asymmetric fan (UAT)

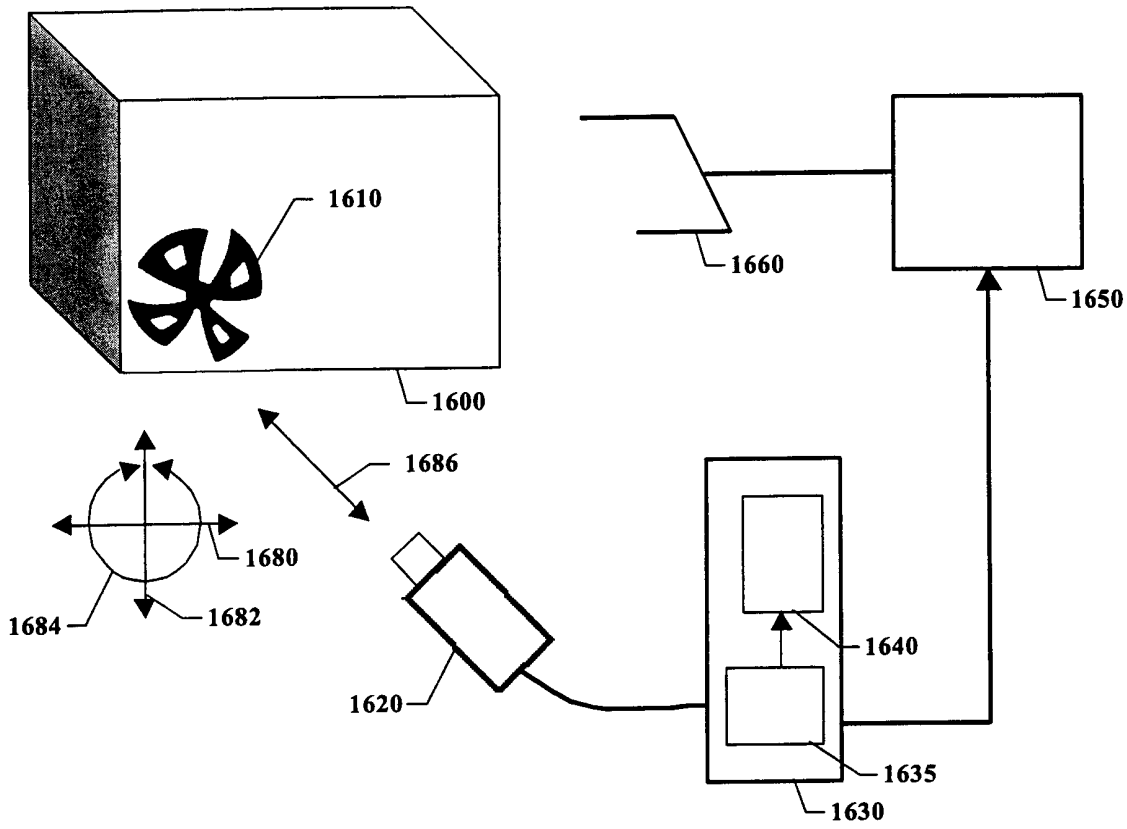

Figure 16—Apparatus for locating objects using a UAT

```

Attribute VB_Name = "shapes"
Option Explicit

Public Type ContourSegment
    x As Double
    y As Double
    len As Double
    udx As Double
    udy As Double
End Type

Public Type ContourList
    segments() As ContourSegment
End Type

Public Type ContourSet
    lists() As ContourList
    perimeter As Double
    centerOfProjectionX As Double
    centerOfProjectionY As Double
    sizeMerit As Double
    angleMerit As Double
    translationMerit(1) As Double
    translationAngle(1) As Double
End Type

Public Sub render(shape As Object, img As Bmp, rp As RenderProfile)
    Dim i As Integer, j As Integer
    Dim x0 As Double, y0 As Double
    x0 = img.width / 2 + 0.5
    y0 = img.Height / 2 - 0.5
    For j = 0 To img.Height - 1
        For i = 0 To img.width - 1
            img.Pixel(i, j) = rp.pixelValue(shape.profileCoord(i - x0, y0 - j))
        Next i
    Next j
End Sub

Public Sub scanContours(shape As Object, step As Double, points As ContourSet)
    Const gate = 0.1 ' radians

```

```

Const maxSteps = 100000
Const block = 100

Dim ci As Integer, cn As Integer
Dim si As Long, pn As Long, done As Boolean
Dim x As Double, y As Double, dx As Double, dy As Double, x0 As Double, y0 As Double
Dim xn As Double, yn As Double, xp As Double, yp As Double
Dim ap As Double, an As Double, r As Double
Dim u As Double, px As Double, py As Double
Dim gt As Double, cs As Double, sn As Double
Dim perimeter As Double

cn = shape.numContours
ReDim points.lists(cn - 1)

For ci = 0 To cn - 1
    ' get starting point, direction
    shape.getContourStart ci, x0, y0
    x = x0
    y = y0
    ap = shape.profileCoord(x + step, y)
    an = shape.profileCoord(x, y + step)
    r = Sqr(ap ^ 2 + an ^ 2)
    dx = an / r
    dy = -ap / r

    si = 0
    ReDim points.lists(ci).segments(block - 1)
    done = False

    Do While Not done And si < maxSteps
        ' rotate gate so contour passes thru
        gt = 0.5 * gate
        an = 0
        Do While True
            cs = Cos(gt)
            sn = Sin(gt)
            xp = x + step * (dx * cs - dy * sn)
            yp = y + step * (dx * sn + dy * cs)
            ap = shape.profileCoord(xp, yp)
            If ap >= 0 Then Exit Do
        Loop
    Loop

```



```

xn = xp
yn = yp
an = ap
gt = gt + gate
If gt >= pi Then Err.Raise vbObjectError + 200, , "Lost contour CCW at (" & Format(x, "0.00") &
", " & Format(y, "0.00") & ") after " & si & " steps"
pn = pn + 1
Loop
If an = 0 Then
Do While True
gt = gt - gate
If gt <= -pi Then Err.Raise vbObjectError + 200, , "Lost contour CW at (" & Format(x, "0.00") &
", " & Format(y, "0.00") & ") after " & si & " steps"
cs = Cos(gt)
sn = Sin(gt)
xn = x + step * (dx * cs - dy * sn)
yn = y + step * (dx * sn + dy * cs)
an = shape.profileCoord(xn, yn)
If an < 0 Then Exit Do
xp = xn
yp = yn
ap = an
pn = pn + 1
Loop
End If

' get next point, distance, direction
xp = xp + (xn - xp) * ap / (ap - an)
yp = yp + (yn - yp) * ap / (ap - an)
r = Sqr((xp - x) ^ 2 + (yp - y) ^ 2)
dx = (xp - x) / r
dy = (yp - y) / r

' test for done
px = x0 - x
py = y0 - y
u = px * dx + py * dy
If 0 < u And u <= 1.01 * r Then
px = px - u * dx
py = py - u * dy
If Sqr(px ^ 2 + py ^ 2) <= step / 2 Then

```

```

xp = x0
yp = y0
r = Sqr((xp - x) ^ 2 + (yp - y) ^ 2)
dx = (xp - x) / r
dy = (yp - y) / r
done = True
End If
End If

' write next point
If si > UBound(points.lists(ci).segments) Then
    ReDim Preserve points.lists(ci).segments(si - 1 + block)
End If

With points.lists(ci).segments(si)
    .x = x
    .y = y
    .len = r
    .udx = dx
    .udy = dy
End With

' update stats
perimeter = perimeter + r
si = si + 1
x = xp
y = yp
Loop
ReDim Preserve points.lists(ci).segments(si - 1)

If Not done Then
    ' logic error in algorithm
    Err.Raise vbObjectError + 201, , "Can't find end of contour"
End If
Next ci

points.perimeter = perimeter
pn = pn + 2 * si + 2
End Sub

Public Sub computeMerit(contours As ContourSet)

```

```

Dim ci As Long, si As Integer, d As Integer
Dim x As Double, y As Double, r As Double, t As Double, cs As Double, sn As Double
Dim Src As Double, Srs As Double, Ss2 As Double, Sc2 As Double, Scs As Double
Dim Sdot As Double, Scross As Double
Dim Strans(179) As Double, csTab(179) As Double, snTab(179) As Double

' center of projection
For ci = 0 To UBound(contours.lists)
  For si = 0 To UBound(contours.lists(ci).segments)
    With contours.lists(ci).segments(si)
      cs = .udy
      sn = -.udx
      r = (.x + .udx * .len / 2) * cs + (.y + .udy * .len / 2) * sn
      Src = Src + .len * r * cs
      Srs = Srs + .len * r * sn
      Ss2 = Ss2 + .len * sn * sn
      Sc2 = Sc2 + .len * cs * cs
      Scs = Scs + .len * cs * sn
    End With
  Next si
Next ci
r = Sc2 * Ss2 - Scs ^ 2
contours.centerOfProjectionX = (Src * Ss2 - Srs * Scs) / r
contours.centerOfProjectionY = (Srs * Sc2 - Src * Scs) / r

' compute sine and cosine tables
For d = 0 To 179
  t = d * degToRad
  csTab(d) = Cos(t)
  snTab(d) = Sin(t)
Next d

' figures of merit
For ci = 0 To UBound(contours.lists)
  For si = 0 To UBound(contours.lists(ci).segments)
    With contours.lists(ci).segments(si)
      ' angle and size
      x = .x + .udx * .len / 2 - contours.centerOfProjectionX
      y = .y + .udy * .len / 2 - contours.centerOfProjectionY
      Sdot = Sdot + .len * Abs(x * .udy - y * .udx)
      Scross = Scross + .len * Abs(x * .udx + y * .udy)
    End With
  Next si
Next ci

```

```

' translation
For d = 0 To 179
    Strans(d) = Strans(d) + .len * Abs(csTab(d) * .udy - snTab(d) * .udx)
Next d
End With
Next si
Next ci
contours.angleMerit = Scross
contours.sizeMerit = Sdot

' translation figures of merit
For d = 0 To 1
    contours.translationMerit(d) = Strans(0)
    contours.translationAngle(d) = 0
Next d
For d = 1 To 179
    If Strans(d) < contours.translationMerit(0) Then
        contours.translationMerit(0) = Strans(d)
        contours.translationAngle(0) = d
    ElseIf Strans(d) > contours.translationMerit(1) Then
        contours.translationMerit(1) = Strans(d)
        contours.translationAngle(1) = d
    End If
Next d
Next d
End Sub

Public Sub drawContours(cs As ContourSet, dsply As Display)
    Dim ci As Long, si As Long
    Dim tblt As New tablet
    Dim xl As Double, yl As Double

    For ci = 0 To UBound(cs.lists)
        xl = cs.lists(ci).segments(UBound(cs.lists(ci).segments)).x
        yl = cs.lists(ci).segments(UBound(cs.lists(ci).segments)).y
        For si = 0 To UBound(cs.lists(ci).segments)
            With cs.lists(ci).segments(si)
                tblt.DrawLine xl, yl, .x, .y, vbGreen
            End With
        Next si
    Next ci
End Sub

```

```
Next si
Next ci

    dsply.DrawSketch tblt, ClientCoordinates
End Sub

Attribute VB_Name = "vbMath"
Option Explicit

Public Const pi = 3.14159265358979
Public Const twopi = 2 * pi
Public Const halfpi = pi / 2
Public Const degToRad = twopi / 360

Public Function atan2(y As Double, x As Double) As Double
    If x = 0 And y = 0 Then Exit Function
    If y > x Then
        If -y > x Then
            ' 135 - 225
            atan2 = pi - Atn(y / -x)
        Else
            ' 45 - 135
            atan2 = halfpi - Atn(x / y)
        End If
    Else
        If -y > x Then
            ' 225 - 315
            atan2 = 1.5 * pi + Atn(x / -y)
        ElseIf y >= 0 Then
            ' 0 - 45
            atan2 = Atn(y / x)
        Else
            ' 315 - 0
            atan2 = twopi + Atn(y / x)
        End If
    End If
End Function

Public Function rmod(x As Double, m As Double) As Double
    rmod = x - Int(x / m) * m
End Function
```

```
Public Function smod(x As Double, m As Double) As Double
    smod = rmod(x + m / 2, m) - m / 2
End Function

Public Function splitmod(lo As Double, hi As Double, m As Double) As Double
    splitmod = rmod(lo + smod(hi - lo, m) / 2, m)
End Function

Public Function min(a As Variant, b As Variant) As Variant
    If a < b Then min = a Else min = b
End Function

Public Function max(a As Variant, b As Variant) As Variant
    If a > b Then max = a Else max = b
End Function

Public Function limit(x As Variant, lo As Variant, hi As Variant) As Variant
    If x <= lo Then
        limit = lo
    ElseIf x >= hi Then
        limit = hi
    Else
        limit = x
    End If
End Function

VERSION 1.0 CLASS
BEGIN
    MultiUse = -1 'True
    Persistable = 0 'NotPersistable
    DataBindingBehavior = 0 'vbNone
    DataSourceBehavior = 0 'vbNone
    MTSTransactionMode = 0 'NotAnMTSObject
END
Attribute VB_Name = "RenderProfile"
Attribute VB_GlobalNameSpace = False
Attribute VB_Creatable = True
Attribute VB_PredeclaredId = False
Attribute VB_Exposed = False
Option Explicit
```

```

Public sigmoid As Double
Public background As Double
Public contrast As Double
Public noise As Double

Public Function realIntensity(profileCoord As Double) As Double
    Dim a As Double

    If sigmoid = 0 Then
        realIntensity = background + (Sgn(profileCoord) + 1) / 2 * contrast
    Else
        a = profileCoord / sigmoid
        If a <= -20 Then
            realIntensity = background
        ElseIf a >= 20 Then
            realIntensity = background + contrast
        Else
            realIntensity = background + contrast / (1# + Exp(-a))
        End If
    End If
End Function

Public Function pixelValue(profileCoord As Double) As Byte
    Dim z As Double
    z = realIntensity(profileCoord) + 0.5
    If z < 0 Then z = 0
    If z > 255 Then z = 255
    pixelValue = z
End Function

VERSION 1.0 CLASS
BEGIN
    MultiUse = -1 'True
    Persistable = 0 'NotPersistable
    DataBindingBehavior = 0 'vbNone
    DataSourceBehavior = 0 'vbNone
    MTSTransactionMode = 0 'NotAnMTSObject
END
Attribute VB_Name = "FanShape"
Attribute VB_GlobalNameSpace = False

```

```

Attribute VB_Creatable = True
Attribute VB_PredeclaredId = False
Attribute VB_Exposed = False
Option Explicit

Const bladeNum = 4

Private Type BladeParams
    azimuth As Double ' start of blade at outer radius, degrees
    width As Double ' width of blade, degrees
    skew As Double ' azimuth difference, outer to origin, degrees
    spiral As Double ' center to edge radius difference, fraction of outer radius
End Type

Private Type FanParams
    outerRad As Double
    innerRad As Double
    round As Double
    blades(bladeNum - 1) As BladeParams
    holeInnerRad As Double
    holeOuterRad As Double
    holeThickness As Double
End Type

Private Type BladeData
    low As Double
    high As Double
    zoneLow As Double
    lowSkew As Double
    zoneWidth As Double
    widthSkew As Double
    center As Double
    halfWidth As Double
    skew As Double
    spiral As Double
    holeZoneT As Double
    holeRadT As Double
    hubRound As Double
    bladeRound As Double
    holeInnerRound As Double
    holeOuterRound As Double

```



```

End Type

Private params As FanParams
Private paramsChanged As Boolean

Private outerRad As Double
Private innerRad As Double
Private blades(bladeNum - 1) As BladeData
Private holeZoneLow As Double
Private holeZoneHigh As Double
Private holeCenterR As Double
Private holeRadR As Double

Private Sub loadFanData(fp As FanParams)
    Dim k As Integer, knext As Integer, kprev As Integer

    With fp
        outerRad = .outerRad
        innerRad = .innerRad * outerRad

        holeZoneLow = .holeInnerRad / 2 * outerRad
        holeZoneHigh = (.holeOuterRad + 1) / 2 * outerRad
        holeCenterR = (.holeInnerRad + .holeOuterRad) / 2 * outerRad
        holeRadR = (.holeOuterRad - .holeInnerRad) / 2 * outerRad

        For k = 0 To bladeNum - 1
            With blades(k)
                .skew = fp.blades(k).skew
                .low = fp.blades(k).azimuth - .skew
                .high = fp.blades(k).width + .low
                .halfWidth = fp.blades(k).width * degToRad / 2
                .center = rmod(.low * degToRad + .halfWidth, twopi)
                .skew = .skew / outerRad * degToRad
                .spiral = fp.blades(k).spiral / .halfWidth * outerRad
                .holeRadT = fp.holeThickness * .halfWidth
                If .holeRadT > 0 Then
                    .holeZoneT = (.holeRadT + .halfWidth) / 2
                Else
                    .holeZoneT = 0
                End If
                .bladeRound = min(fp.round, min((outerRad - innerRad) / 2, .halfWidth * outerRad))
            End With
        Next k
    End With
End Sub

```

```

.holeInnerRound = min(fp.round, min(holeRadR, .holeRadT * fp.holeInnerRad * outerRad))
.holeOuterRound = min(fp.round, min(holeRadR, .holeRadT * fp.holeOuterRad * outerRad))
End With
Next k

For k = 0 To bladeNum - 1
  With blades(k)
    knext = (k + 1) Mod bladeNum
    kprev = (k - 1 + bladeNum) Mod bladeNum
    .zoneLow = splitmod(blades(kprev).high, .low, 360) * degToRad
    .lowSkew = (.skew + blades(kprev).skew) / 2
    .zoneWidth = rmod(splitmod(.high, blades(knext).low, 360) * degToRad - .zoneLow, twopi)
    .widthSkew = (.skew + blades(knext).skew) / 2 - .lowSkew
    .hubRound = min(fp.round, min((outerRad - innerRad) / 2, max(smod((.center - .halfWidth +
    * innerRad / 2)) - (blades(kprev).center + blades(kprev).halfWidth + innerRad * blades(kprev).skew), twopi), 0)
  End With
Next k

Private Sub getFanData()
  If paramsChanged Then
    loadFanData params
    paramsChanged = False
  End If
End Sub

Public Function profileCoord(x As Double, y As Double) As Double
  Dim k As Integer
  Dim r As Double, t As Double, u As Double, v As Double, w As Double, round As Double
  Dim rh As Double, rp As Double, a As Double

  getFanData
  r = Sqr(x ^ 2 + y ^ 2)
  t = atan2(y, x)

  ' figure out which blade to make
  For k = 0 To bladeNum - 1
    With blades(k)

```

```

    If rmod(t - (.zoneLow + r * .lowSkew), twopi) < .zoneWidth + r * .widthSkew Then Exit For
  End With
Next k
If k = bladeNum Then Err.Raise vbObjectError + 100, , "Bad blade detection logic"

With blades(k)
  ' get blade relative azimuth
  t = t - r * .skew
  t = smod(t - .center, twopi)
  xp = r - t * .spiral
  If t >= 0 Then
    round = blades((k + 1) Mod bladeNum).hubRound
  Else
    t = -t
    round = .hubRound
  End If

  ' determine zone and distance from edge
  ' "<" instead of "<=" so hole can be disabled
  If holeZoneLow < xp And rp < holeZoneHigh And t < .holeZoneT Then
    rh = xp - holeCenterR
    If rh >= 0 Then
      round = .holeOuterRound
    Else
      rh = -rh
      round = .holeInnerRound
    End If
    u = rh - (holeRadR - round)
    v = r * t - (r * .holeRadT - round)
    If u > 0 And v > 0 Then
      a = Sqr(u ^ 2 + v ^ 2) - round
    ElseIf rh - holeRadR >= r * (t - .holeRadT) Then
      a = rh - holeRadR
    Else
      a = r * (t - .holeRadT)
    End If
  Else
    u = rp - (outerRad - .bladeRound)
    v = r * t - (r * .halfWidth - .bladeRound)
    If u > 0 And v > 0 Then
      a = .bladeRound - Sqr(u ^ 2 + v ^ 2)
    End If
  End With
End With

```

```

Else
    u = r - (innerRad + round)
    v = r * t - (r * .halfWidth + round)
    If u < 0 And v < 0 Then
        a = Sqr(u ^ 2 + v ^ 2) - round
    ElseIf rp - outerRad >= r * (t - .halfWidth) Then
        a = outerRad - rp
    ElseIf r - innerRad >= r * (t - .halfWidth) Then
        a = r * (.halfWidth - t)
    Else
        a = innerRad - r
    End If
End If
End If
End With

profileCoord = a
End Function

Public Sub render(img As Bmp, rp As RenderProfile)
    Dim i As Integer, j As Integer
    Dim x0 As Double, y0 As Double

    x0 = img.width / 2 + 0.5
    y0 = img.Height / 2 - 0.5
    For j = 0 To img.Height - 1
        For i = 0 To img.width - 1
            img.Pixel(i, j) = rp.pixelValue(profileCoord(i - x0, y0 - j))
        Next i
    Next j
End Sub

Public Property Get numBlades() As Variant
    numBlades = bladeNum
End Property

Public Property Get outerRadius() As Double
    outerRadius = params.outerRad
End Property

Public Property Let outerRadius(ByVal vNewValue As Double)

```

```
    params.outerRad = max(vNewValue, 0)
    params.Changed = True
End Property

Public Property Get innerRadius() As Double
Attribute innerRadius.VB_Description = "Radius of fan hub, fraction of outer radius"
innerRadius = params.innerRad
End Property

Public Property Let innerRadius(ByVal vNewValue As Double)
params.innerRad = limit(vNewValue, 0, 1)
params.Changed = True
End Property

Public Property Get cornerRound() As Double
Attribute cornerRound.VB_Description = "Corner radius, absolute units"
cornerRound = params.round
End Property

Public Property Let cornerRound(ByVal vNewValue As Double)
params.round = max(vNewValue, 0)
params.Changed = True
End Property

Public Property Get azimuth(bn As Integer) As Double
Attribute azimuth.VB_Description = "Azimuth of blade bn in degrees"
azimuth = params.blades(bn).azimuth
End Property

Public Property Let azimuth(bn As Integer, ByVal vNewValue As Double)
params.blades(bn).azimuth = rmod(vNewValue, 360)
params.Changed = True
End Property

Public Property Get width(bn As Integer) As Double
Attribute width.VB_Description = "Width of blade bn in degrees"
width = params.blades(bn).width
End Property

Public Property Let width(bn As Integer, ByVal vNewValue As Double)
params.blades(bn).width = limit(vNewValue, 0, 360)
```

```

    paramsChanged = True
End Property

Public Property Get skew(bn As Integer) As Double
Attribute skew.VB_Description = "Blade skew (hub to circumference offset) in degrees"
    skew = params.blades(bn).skew
End Property

Public Property Let skew(bn As Integer, ByVal vNewValue As Double)
    params.blades(bn).skew = limit(vNewValue, -90, 90)
    paramsChanged = True
End Property

Public Property Get spiral(bn As Integer) As Double
Attribute spiral.VB_Description = "Outer blade edge radial difference"
    spiral = params.blades(bn).spiral
End Property

Public Property Let spiral(bn As Integer, ByVal vNewValue As Double)
    params.blades(bn).spiral = limit(vNewValue, -0.5, 0.5)
    paramsChanged = True
End Property

Public Property Get holeInnerRadius() As Double
Attribute holeInnerRadius.VB_Description = "Fraction of outerRadius"
    holeInnerRadius = params.holeInnerRad
End Property

Public Property Let holeInnerRadius(ByVal vNewValue As Double)
    params.holeInnerRad = limit(vNewValue, 0, 1)
    paramsChanged = True
End Property

Public Property Get holeOuterRadius() As Double
Attribute holeOuterRadius.VB_Description = "Fraction of outerRadius"
    holeOuterRadius = params.holeOuterRad
End Property

Public Property Let holeOuterRadius(ByVal vNewValue As Double)
    params.holeOuterRad = limit(vNewValue, 0, 1)
    paramsChanged = True

```

```

End Property

Public Property Get holeWidth() As Double
Attribute holeWidth.VB_Description = "Width of holes, fraction of blade widths"
holeWidth = params.holeThickness
End Property

Public Property Let holeWidth(ByVal vNewValue As Double)
params.holeThickness = limit(vNewValue, 0, 1)
params.Changed = True
End Property

Public Property Get numContours() As Integer
If params.holeThickness > 0 Then
    numContours = 5
Else
    numContours = 1
End If
End Property

Public Sub getContourStart(i As Integer, x As Double, y As Double)
Dim r As Double, t As Double, k As Integer

getFanData
Select Case i
Case 0
    r = outerRad
    k = 0

Case 1 To 4
    r = holeCenterR + holeRadR
    k = i - 1
End Select

t = blades(k).center + r * blades(k).skew
x = r * Cos(t)
y = r * Sin(t)
End Sub

Private Sub Class_Initialize()
Dim i As Integer

```

```
With params
.outerRad = 128
.innerRad = 0.2
.round = 6
.holeInnerRad = 0.5
.holeOuterRad = 0.8
.holeThickness = 0.33
For i = 0 To bladeNum - 1
  With .blades(i)
    .azimuth = (i + 0.25) * 360 / bladeNum
    .width = 360# / (2 * bladeNum)
    .skew = 0
    .spiral = 0
  End With
Next i
End With
paramsChanged = True
End Sub
```

INTERNATIONAL SEARCH REPORT

International Application No

PCT/US 00/29952

A. CLASSIFICATION OF SUBJECT MATTER
 IPC 7 G06T7/00 G01B11/00 B07C1/06 B25J9/16 G03F9/00

According to International Patent Classification (IPC) or to both national classification and IPC

B. FIELDS SEARCHED
 Minimum documentation searched (classification system followed by classification symbols)
 IPC 7 G06T G01B B07C B25J G03F

Documentation searched other than minimum documentation to the extent that such documents are included in the fields searched

Electronic data base consulted during the international search (name of data base and, where practical, search terms used)
 EPO-Internal, WPI Data, PAJ

C. DOCUMENTS CONSIDERED TO BE RELEVANT

Category °	Citation of document, with indication, where appropriate, of the relevant passages	Relevant to claim No.
X	WO 98 18117 A (COGNEX CORP) 30 April 1998 (1998-04-30) page 7, line 3 -page 8, line 30; figure 1 ---	1
X	US 5 974 365 A (MITCHELL ROBERT R) 26 October 1999 (1999-10-26) column 1, line 31 - line 38; figure 2 ---	1
X	US 5 960 125 A (WALLACK AARON ET AL) 28 September 1999 (1999-09-28) column 6, line 13 - line 67; figure 3 -----	1

Further documents are listed in the continuation of box C. Patent family members are listed in annex.

° Special categories of cited documents :

<p>*A* document defining the general state of the art which is not considered to be of particular relevance</p> <p>*E* earlier document but published on or after the international filing date</p> <p>*L* document which may throw doubts on priority claim(s) or which is cited to establish the publication date of another citation or other special reason (as specified)</p> <p>*O* document referring to an oral disclosure, use, exhibition or other means</p> <p>*P* document published prior to the international filing date but later than the priority date claimed</p>	<p>*T* later document published after the international filing date or priority date and not in conflict with the application but cited to understand the principle or theory underlying the invention</p> <p>*X* document of particular relevance; the claimed invention cannot be considered novel or cannot be considered to involve an inventive step when the document is taken alone</p> <p>*Y* document of particular relevance; the claimed invention cannot be considered to involve an inventive step when the document is combined with one or more other such documents, such combination being obvious to a person skilled in the art.</p> <p>* & * document member of the same patent family</p>
--	--

Date of the actual completion of the international search 15 March 2001	Date of mailing of the international search report 22/03/2001
---	---

Name and mailing address of the ISA European Patent Office, P.B. 5818 Patentlaan 2 NL - 2280 HV Rijswijk Tel. (+31-70) 340-2040, Tx. 31 651 epo nl, Fax: (+31-70) 340-3016	Authorized officer Anderson, A
--	--

INTERNATIONAL SEARCH REPORT

Information on patent family members

International Application No

PCT/US 00/29952

Patent document cited in search report	Publication date	Patent family member(s)	Publication date
WO 9818117 A	30-04-1998	US 6137893 A EP 0883857 A	24-10-2000 16-12-1998
US 5974365 A	26-10-1999	NONE	
US 5960125 A	28-09-1999	NONE	