

(19) World Intellectual Property Organization  
International Bureau



(43) International Publication Date  
4 November 2004 (04.11.2004)

PCT

(10) International Publication Number  
WO 2004/093547 A1

(51) International Patent Classification<sup>7</sup>: A21B 3/13,  
B65D 5/30, 5/24, 5/40, 81/34

New South Wales 2068 (AU). CHRISTOPHERSEN, Tony [AU/AU]; 90 Longman Terrace, Chelmer, Queensland 4068 (AU).

(21) International Application Number:  
PCT/AU2004/000517

(74) Agent: GRIFFITH HACK; 509 St Kilda Road, Melbourne, Victoria 3004 (AU).

(22) International Filing Date: 21 April 2004 (21.04.2004)

(81) Designated States (unless otherwise indicated, for every kind of national protection available): AE, AG, AL, AM, AT, AU, AZ, BA, BB, BG, BR, BW, BY, BZ, CA, CH, CN, CO, CR, CU, CZ, DE, DK, DM, DZ, EC, EE, EG, ES, FI, GB, GD, GE, GH, GM, HR, HU, ID, IL, IN, IS, JP, KE, KG, KP, KR, KZ, LC, LK, LR, LS, LT, LU, LV, MA, MD, MG, MK, MN, MW, MX, MZ, NA, NI, NO, NZ, OM, PG, PH, PL, PT, RO, RU, SC, SD, SE, SG, SK, SL, SY, TJ, TM, TN, TR, TT, TZ, UA, UG, US, UZ, VC, VN, YU, ZA, ZM, ZW.

(25) Filing Language: English

(26) Publication Language: English

(30) Priority Data:  
2003901887 22 April 2003 (22.04.2003) AU

(71) Applicants (for all designated States except US): AMCOR LIMITED [AU/AU]; 679 Victoria Street, Abbotsford, Victoria 3067 (AU). DANE PTY LTD [AU/AU]; 90 Longman Street, Chelmer, Queensland 4068 (AU).

(84) Designated States (unless otherwise indicated, for every kind of regional protection available): ARIPO (BW, GH, GM, KE, LS, MW, MZ, SD, SL, SZ, TZ, UG, ZM, ZW), Eurasian (AM, AZ, BY, KG, KZ, MD, RU, TJ, TM), European (AT, BE, BG, CH, CY, CZ, DE, DK, EE, ES, FI, FR, GB, GR, HU, IE, IT, LU, MC, NL, PL, PT, RO, SE, SI, SK,

(72) Inventors; and  
(75) Inventors/Applicants (for US only): HAMBLIN, Ronald, Geoffrey [GB/AU]; 52 Hector Road, Willoughby,

[Continued on next page]

(54) Title: A BAKING TRAY

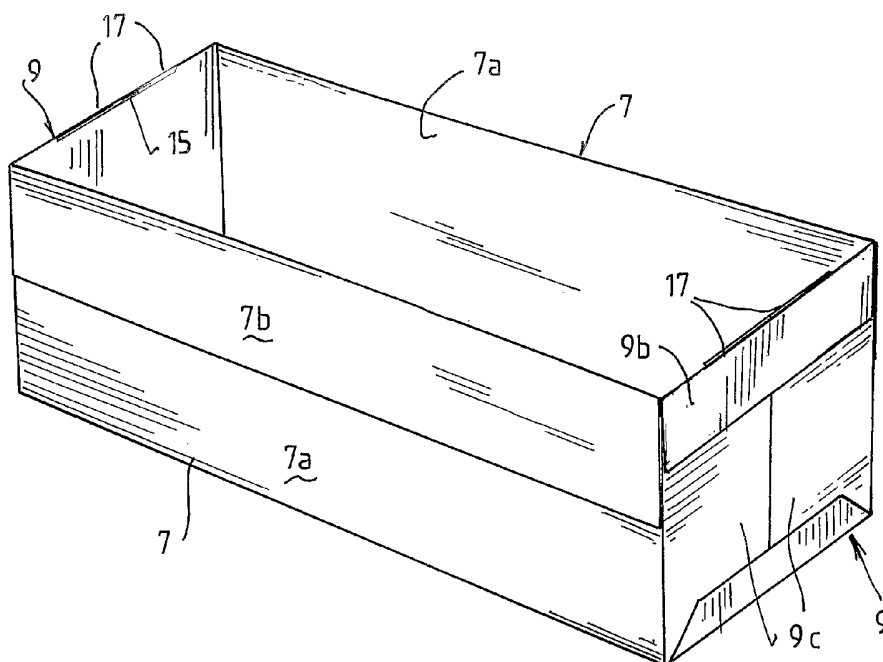

(57) Abstract: A corrugated or other suitable carton board tray for baking a food product in the tray is disclosed. The tray includes a rectangular base (5), upright side walls (7), upright end walls (9), and a locking assembly (15, 17) that holds the side walls and the end walls in upright positions with the corners of the tray and therefore the corners of the baked food product produced in the tray being straight and squared. A blank for forming the tray is also disclosed.

WO 2004/093547 A1



TR), OAPI (BF, BJ, CF, CG, CI, CM, GA, GN, GQ, GW, ML, MR, NE, SN, TD, TG).

*For two-letter codes and other abbreviations, refer to the "Guidance Notes on Codes and Abbreviations" appearing at the beginning of each regular issue of the PCT Gazette.*

**Published:**

— *with international search report*

- 1 -

## A BAKING TRAY

The present invention relates to a corrugated or other suitable carton board tray for baking food products, such as cakes.

The present invention also relates to a corrugated or other suitable carton board blank for forming the tray.

Bakeries often cut baked food products, such as cakes, into smaller portions for sale at retail outlets. For commercial reasons, it is important that the cut portions be a uniform size and shape. Typically, bakeries cut baked products using precision cutting equipment, such as sonic and laser cutters, which are able to cut the products with a high degree of dimensional accuracy and produce sharp well-defined cuts. However, in order to produce cut portions of uniform size and shape it is important that the as-baked products be dimensionally accurate. The as-baked shapes of the products are directly related to the shapes of the trays in which the products are baked.

Metal baking trays, which are the main type of baking trays that are currently used in bakeries, can be made to a high degree of dimensional accuracy. However, traditionally, metal baking trays have tapered side walls and rounded corners to facilitate the manufacturing process of pressing the trays and to facilitate removing baked products from the trays. Thus, the corners of the baked products are not straight and squared. Therefore, these metal baking trays are not adapted to bake products that can be cut into portions having a uniform size and shape.

It is known to manufacture metal baking trays

- 2 -

with square side walls and square corners (rather than with tapered side walls and rounded corners). However, these trays do not nest and therefore there are issues with handling large numbers of the trays - as would be  
5 necessary in bakeries. In addition, it is relatively difficult to remove baked products from these trays.

There have been proposals to use corrugated board baking trays as an alternative to metal baking trays.  
10 However, the current proposals for such trays are not dimensionally accurate, with the result that there can be undesirable substantial variations in size and shape of portions cut from baked products made in these trays.

15 An object of the present invention is to provide a corrugated or other suitable carton board baking tray that is capable of producing baked products with a high degree of dimensional accuracy.

20 The present invention provides a corrugated or other suitable carton board tray for baking a food product in the tray that includes a rectangular (which term includes square) base, upright side walls, upright end walls, and a locking assembly that holds the side walls  
25 and the end walls in upright positions with the corners of the tray and therefore the corners of the baked food product produced in the tray being straight and squared.

30 Preferably each side wall of the tray is inwardly concave along its length between the end walls so that the side walls can flex outwardly to form side walls that are perpendicular to the base and perpendicular to the end walls as the food product in the tray expands during  
baking.

35

Preferably the locking assembly releasably holds together the end walls and the side walls of the tray so

- 3 -

that the end walls and the side walls can be folded outwardly and downwardly to provide access to the food product that has been baked in the tray.

5                    Preferably the locking assembly includes locking tabs on the side walls and slots in the end walls that receive the locking tabs and releasably hold together the end walls and the side walls.

10                   Preferably the side walls include flaps that form part of the end walls of the tray.

                    Preferably the locking tabs extend from the flaps.

15                   Preferably each side wall flap includes at least one locking tab that extends from an upper edge of the side wall flap.

20                   Preferably the tray includes gusset corners in a lower section of the tray.

                    Preferably the gusset corners extend no more than one third of the height of the tray.

25                   The present invention also provides a blank of a corrugated or any other suitable carton board material for forming the above-described tray.

30                   The blank includes a series of panels separated by fold lines.

                    The panels include a base panel that forms the base of the tray and side wall panels adjoining the base panel along opposite sides of the base panel. The side wall panels form the upright side walls of the tray.

35

- 4 -

The panels also include end wall panels adjoining the base panel at opposite ends of the base panel (hereinafter referred to as the "base flaps") and end wall panels adjoining the side wall panels at opposite ends of the side wall panels (hereinafter referred to as "side wall flaps"). The base and side wall flaps form the end walls of the tray.

Preferably the side wall flaps and the base flaps include the locking assembly.

Preferably the side wall flaps include locking tabs and the base flaps include slots that can receive the locking tabs when the base and side wall flaps are in folded positions.

The present invention also provides a method of forming the above-described tray from a flat blank.

In accordance with the method, each side wall is formed by folding the side wall panels upwardly at the fold lines that separate the side wall panels and the base panels.

Thereafter, each end wall is formed by (a) folding the base flap at that end upwardly at the fold line that separates the base flap and the base panel, and (b) folding the side wall flaps at that end inwardly at the fold lines that separate the side wall flaps and the side wall panels to bring the side wall flaps into contact with the outer surface of the upstanding base flap.

Thereafter, the locking assembly is engaged to lock together the side wall flaps and the base flaps and thereby hold the side wall flaps against the base flaps.

The action of folding the side wall flaps

- 5 -

inwardly has the effect of bringing the upstanding side wall panels of the tray into contact with side edges of the upstanding base flap and thereby forming the corners between adjacent side and end walls.

5

Preferably the method includes engaging the locking assembly by inserting the locking tabs on the side wall flaps into the slots in the base flaps when the base and side wall flaps are in folded positions and thereby  
10 holding the side wall flaps against the base flaps.

Preferably the locking assembly is formed so that the side wall flaps at each end of the tray are pulled inwardly towards each other and thereby force the  
15 side wall panels into close contact with the side edges of the upstanding base flaps. This feature contributes to forming straight and squared corners between the side and end walls.

Preferably adjacent base flaps and side wall flaps are partly joined together by gusset panels that form gusset corners in a lower section of the tray. The gusset corners prevent liquids in a baking mix and generated during baking a food product from escaping from  
25 the tray. By confining the gusset corners to the lower section of the tray, the gusset corners do not interfere with the close contact between adjacent side and end walls at these corners of the tray that is achieved with the above-described arrangement of the base and side wall  
30 flaps.

Preferably the gusset corners extend no more than one third of the height of the tray.

35 The applicant has found that the above-described tray, and more particularly the end wall construction of the upwardly folded base flaps and the inwardly folded

- 6 -

side wall flaps that are held together by the described locking assemblies of locking tabs and slots, makes it possible to form straight and squared corners between the side walls and the end walls of the tray.

5

In addition, the applicant has found that the locking assemblies of locking tabs and slots facilitate quick and easy erection of the tray from the flat blank.

10

In addition, the locking assemblies of locking tabs and slots can be quickly and easily unlocked so that one or both end walls can be "unfolded" to facilitate removal of cut portions of baked products from the tray and can then be "re-folded" and locked to re-form the end wall or walls to store remaining cut portions in the tray.

15

Preferably an upper edge of each side wall of the tray is formed by folding an upper section of the side wall panel outwardly and downwardly against an outer surface of a lower section of the side wall panel and gluing or otherwise holding the folded upper section against the outer surface.

20

Preferably an upper edge of each end wall of the tray is formed by folding an upper section of the base flap outwardly and downwardly against an outer surface of upper sections of the side wall flaps.

25

Preferably the slots in the base flaps are positioned so that the slots are on the upper edges of the end walls.

30

The present invention also provides a method of baking a food product in the above-described tray and thereafter at least partially packaging the baked food product which includes depositing a predetermined amount of unbaked food product mix in the tray, baking the food

35

- 7 -

product in the tray, and packaging the baked food product located in the tray so that the baked food product can be transported to an end use location.

5            Preferably the method further includes cutting the baked food product into smaller portions in the tray.

            Preferably the cut smaller portions are substantially uniform size and shape.

10

            The present invention is described further with reference to the accompanying drawings, of which:

            Figure 1 is a perspective view of a preferred embodiment of a baking tray in accordance with the present invention;

            Figure 2 is a top plan view of the tray shown in Figure 1 which illustrates the arrangement of the base flap and side wall flaps at one end of the tray prior to the flaps being folded upwardly and inwardly, respectively, to form that end wall of the tray; and

            Figure 3 is a top plan view of a blank for forming the tray shown in Figures 1 and 2.

            The baking tray shown in Figure 1 is formed from corrugated or any other suitable carton board which has (a) a bleached lining on the surfaces of the board that form the interior and an upper section of the exterior of the box, and (b) a heat resistant polyolefin or other suitable coating on the bleached lining.

            The tray is orthogonal with a rectangular base 5, upright side walls 7, and upright end walls 9.

            The side walls 7 and the end walls 9 are folded

- 8 -

outwardly so that the upper edges of these walls form generally smooth surfaces.

5           The lower sections of the corners between adjacent side and end walls 7, 9 are formed as gusset corners to prevent the escape of liquids from the tray. These gusset corners extend only part way up the height of the tray.

10           As is described in more detail hereinafter, the tray is formed so that the corners between (a) the base 5 and the side walls 7, (b) the base 5 and the end walls 9, and (c) the side walls 7 and the end walls 9, are straight and square. This construction ensures that a baked  
15           product produced in the tray has straight and squared corners and straight sides and therefore has a high degree of dimensional accuracy. As is indicated above, this is an important consideration in terms of cutting the baked product into portions that have a uniform size and shape.

20           In addition to the above, the side walls 7 of the tray are inwardly concave along the length of the side walls 7 by a small amount to accommodate outward bulging of the side walls 7 as a food product is baked in the  
25           tray.

          The tray is formed by folding the corrugated board blank shown in Figure 3. One face of the blank has the above-described bleached lining and heat resistant  
30           polyolefin coating on the bleached lining.

          With reference to Figure 3, the blank includes a series of fold lines 11 that define a series of panels.

35           The panels include a base panel 5 that forms the base 5 of the tray.

- 9 -

The panels also include side wall panels 7a that adjoin the base panel 5 at opposite sides of the base panel 5 and side wall panels 7b that adjoin the side wall panels 7a. These side wall panels 7a, 7b form the side walls 7 of the tray.

The panels also include base flaps 9a that adjoin the base panel 5 at opposite sides of the base panel 5, base flaps 9b that adjoin the base flaps 9a, and side wall flaps 9c that adjoin the side wall flaps 7a at opposite sides of the side wall panels 7a. These flaps 9a, 9b, 9c, which can be collectively described as end wall flaps, form the end walls 9 of the tray.

The fold lines 11 between the pairs of base flaps 9a, 9b are scored part way along their length to form slots 15. In addition, the side wall flaps 9c include outwardly projecting tabs 17. As is described hereinafter, the slots 15 and the tabs 17 form locking assemblies that hold the end flaps 9a, 9b, 9c together to form the end walls 9 of the tray.

The panels also include gusset panels 21 that partly join together adjacent base flaps 9a and side wall flaps 9c to form the gusset corners 13.

The tray is formed from the blank by firstly folding the side wall panels 7b about the fold lines 11 that separate the pairs of side wall panels 7a and 7b so that the non-bleached faces of the side wall panels 7b contact the non-bleached faces of the side wall panels 7a and thereafter gluing the faces together. This step produces side walls 7 with smooth upper edges.

The next step in erecting the tray is to fold the glued together side wall panels 7a, 7b upwardly about the fold lines 11 that separate the side wall panels 7a and

- 10 -

the base panel 5 to form the upstanding side walls 7 of the tray.

Thereafter, the base flaps 9a, 9b are folded  
5 upwardly and inwardly to upstanding positions and the side wall flaps 9c are folded inwardly against the outwardly facing surfaces of the upstanding base flaps 9a. This movement of the side wall flaps 9c brings the upstanding side wall panels 7a into close contact with the side edges  
10 of the upstanding base flaps 9a and forms the corners between adjacent side walls 7 and end walls 9.

The base flaps 9a and side wall flaps 9c are held in contact by means of the above-described slots 15 and  
15 locking tabs 17. The positions of these components of locking assemblies are selected so that a step of folding the base flaps 9b outwardly and downwardly positions the slots 15 to form part of the upper edges of the end walls 9 and positions the locking tabs 17 to extend upwardly  
20 through the slots 15 so that the locking tabs 17 are retained by the slots.

The positions of the slots 15 and the locking tabs 17 are also selected so that it is necessary to force  
25 the side wall flaps 9c inwardly in order to align the locking tabs 17 carried by these flaps 9c to be received in the slots 15 and this inward movement further promotes close contact between the side walls 7 and the side edges of the upstanding base flaps 9a that form the corners.

30

The above-described tray can be formed without difficulty on conventional cutting, folding and gluing machinery.

35

In use in a bakery, a predetermined amount of unbaked food product mix is deposited in the above-described tray and the tray and food product mix are

- 11 -

thereafter placed in an oven and the food product is baked  
in the tray. At the end of a required baking time, the  
tray and baked food product are removed from the oven and  
the food product is allowed to cool to a required extent  
5 in the tray. Thereafter, the cooled food product is cut  
into smaller portions of uniform size and shape using  
laser or other suitable precision cutting equipment. At  
his point, the tray forms part of the packaging of the now  
cut baked food product. The packaging of the baked food  
10 product located in the tray is completed as required the  
packaged product is ready to be transported to an end use  
location for use at the location.

Many modifications may be made to the preferred  
15 embodiment of the tray without departing from the spirit  
and scope of the invention.

- 12 -

## CLAIMS:

1. A corrugated or other suitable carton board tray for baking a food product in the tray that includes a rectangular base, upright side walls, upright end walls, and a locking assembly that holds the side walls and the end walls in upright positions with the corners of the tray and therefore the corners of the baked food product produced in the tray being straight and squared.
2. The tray defined in claim 1 wherein each side wall of the tray is inwardly concave along its length between the end walls so that the side walls can flex outwardly to form side walls that are perpendicular to the base and perpendicular to the end walls as the food product in the tray expands during baking.
3. The tray defined in claim 1 or claim 2 wherein the locking assembly releasably holds together the end walls and the side walls of the tray so that the end walls and the side walls can be folded outwardly and downwardly to provide access to the food product that has been baked in the tray.
4. The tray defined in claim 3 wherein the locking assembly includes locking tabs on the side walls and slots in the end walls that receive the locking tabs and releasably hold together the end walls and the side walls.
5. The tray defined in claim 4 wherein the side walls include flaps that are form part of the end walls of the tray.
6. The tray defined in claim 5 wherein the locking tabs extend from the flaps.
7. The tray defined in any one of the preceding

- 13 -

claims includes gusset corners in a lower section of the tray.

8. The tray defined in claim 7 wherein the gusset  
5 corners extend no more than one third of the height of the tray.

9. A blank of a corrugated or any other suitable  
carton board material for forming the tray defined in any  
10 one of the preceding claims includes a series of panels separated by fold lines and the panels include (a) a base panel that is adapted to form the base of the tray, (b) side wall panels adjoining the base panel along opposite sides of the base panel that are adapted to form the  
15 upright side walls of the tray, (c) end wall panels adjoining the base panel at opposite ends of the base panel (hereinafter referred to as the "base flaps"), and (d) end wall panels adjoining the side wall panels at opposite ends of the side wall panels (hereinafter  
20 referred to as "side wall flaps"), wherein the base flaps and the side wall flaps are adapted to form the end walls of the tray, and wherein the base flaps and the side wall flaps include the locking assembly.

25 10. The blank defined in claim 9 wherein the side wall flaps include locking tabs and the base flaps include slots that can receive the locking tabs when the base and side wall flaps are in folded positions.

30 11. The blank defined in claim 9 or claim 10 wherein adjacent base flaps and side wall flaps are partly joined together by gusset panels that are adapted to form gusset corners in a lower section of the tray.

35 12. A method of forming the tray defined in any one of the preceding claims from the blank defined in any one of claims 9 to 11 includes the steps of (a) forming each

- 14 -

side wall by folding the side wall panels upwardly at the fold lines that separate the side wall panels and the base panels and (b) forming each end wall by (i) folding the base flap at that end upwardly at the fold line that  
5 separates the base flap and the base panel, and (ii) folding the side wall flaps at that end inwardly at the fold lines that separate the side wall flaps and the side wall panels to bring the side wall flaps into contact with the outer surface of the upstanding base flap, and (c)  
10 engaging the locking assembly to lock together the side wall flaps and the base flaps.

13. The method defined in claim 12 further includes engaging the locking assembly by inserting the locking  
15 tabs on the side wall flaps into the slots in the base flaps when the base and side wall flaps are in folded positions and thereby holding the side wall flaps against the base flaps.

20 14 A method of baking a food product in the tray defined in any one of claims 1 to 8 and thereafter at least partially packaging the baked food product includes the steps of (a) depositing a predetermined amount of unbaked food product mix in the tray, (b) baking the food  
25 product in the tray, and (c) packaging the baked food product located in the tray so that the baked food product can be transported to an end use location.

15. The method defined in claim 14 further includes  
30 cutting the baked food product into smaller portions in the tray.

16. The method defined in claim 15 includes cutting  
35 the baked food product into smaller portions of substantially uniform size and shape in the tray.



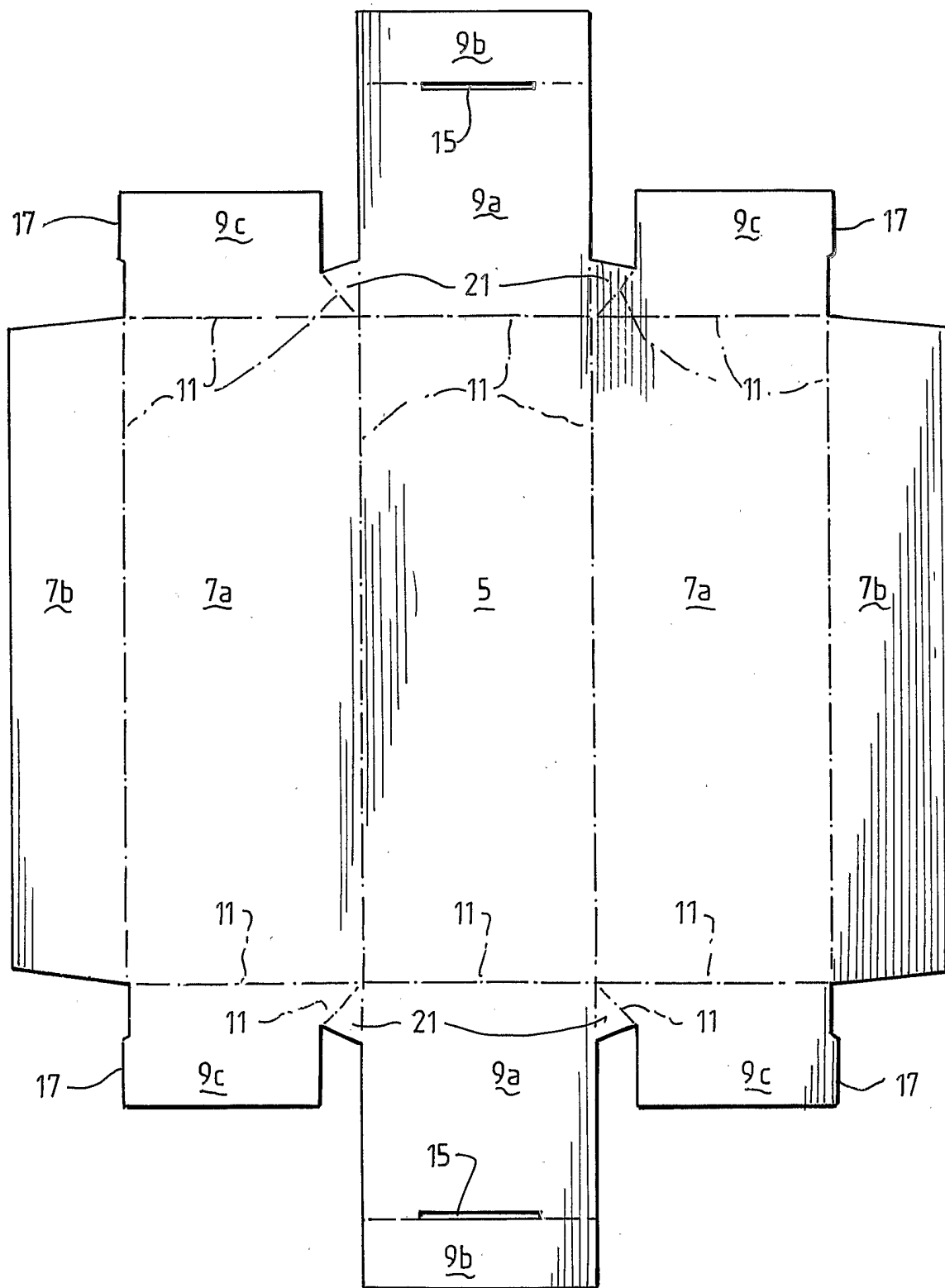

III. 3.

## INTERNATIONAL SEARCH REPORT

International application No.  
**PCT/AU2004/000517**

<b>A. CLASSIFICATION OF SUBJECT MATTER</b> Int. Cl. <sup>7</sup> : A21B 3/13; B65D 5/30, 5/24, 5/40, 81/34 According to International Patent Classification (IPC) or to both national classification and IPC		
<b>B. FIELDS SEARCHED</b> Minimum documentation searched (classification system followed by classification symbols) Documentation searched other than minimum documentation to the extent that such documents are included in the fields searched AU: IPC A21B 3/13; B65D 5/24, 5/30, 5/40, 81/34 Electronic data base consulted during the international search (name of data base and, where practicable, search terms used) DWPI: IPC A21B, B65D with keywords such as baking, tray, carton and similar terms.		
<b>C. DOCUMENTS CONSIDERED TO BE RELEVANT</b>		
Category*	Citation of document, with indication, where appropriate, of the relevant passages	Relevant to claim No.
X Y	US 4573633 A (BRIAN) 4 March 1986 Whole document Whole document	1, 3-6, 9, 10, 14 7, 8, 11-13, 15, 16
Y	WO 2000/053505 A (AMCOR LIMITED) 14 September 2000 Whole document	1, 3-16
Y	US 4371110 A (KULIG) 1 February 1983 Whole document	1, 3-16
Y	US 4260098 A (MANIZZA et al) 7 April 1981 Whole document	1, 3-16
<input checked="" type="checkbox"/> Further documents are listed in the continuation of Box C <input checked="" type="checkbox"/> See patent family annex		
* Special categories of cited documents:		
"A" document defining the general state of the art which is not considered to be of particular relevance	"T" later document published after the international filing date or priority date and not in conflict with the application but cited to understand the principle or theory underlying the invention	
"E" earlier application or patent but published on or after the international filing date	"X" document of particular relevance; the claimed invention cannot be considered novel or cannot be considered to involve an inventive step when the document is taken alone	
"L" document which may throw doubts on priority claim(s) or which is cited to establish the publication date of another citation or other special reason (as specified)	"Y" document of particular relevance; the claimed invention cannot be considered to involve an inventive step when the document is combined with one or more other such documents, such combination being obvious to a person skilled in the art	
"O" document referring to an oral disclosure, use, exhibition or other means	"&" document member of the same patent family	
"P" document published prior to the international filing date but later than the priority date claimed		
Date of the actual completion of the international search 26 May 2004	Date of mailing of the international search report <b>01 JUN 2004</b>	
Name and mailing address of the ISA/AU AUSTRALIAN PATENT OFFICE PO BOX 200, WODEN ACT 2606, AUSTRALIA E-mail address: pct@ipaaustralia.gov.au Facsimile No. (02) 6285 3929	Authorized officer  <b>JEFFREY CARL</b> Telephone No : (02) 6283 2543	

## INTERNATIONAL SEARCH REPORT

International application No.

PCT/AU2004/000517

C (Continuation). DOCUMENTS CONSIDERED TO BE RELEVANT		
Category*	Citation of document, with indication, where appropriate, of the relevant passages	Relevant to claim No.
Y	US 2944719 A (ARNESON) 12 July 1960 Whole document	1, 3-16
Y	US 4114797 A (MANIZZA) 19 September 1978 Whole document	1, 3-16
Y	US 4208007 A (BAMBURG et al) 17 June 1980 Whole document	1, 3-16
A	WO 1998/017539 A (NOVACART S.P.A.) 30 April 1998	
<p><u>NOTE:</u> For the 'Y' indications, US 4114797 or US 4208007 can be combined with any one of the other documents for the claims indicated.</p>		

## INTERNATIONAL SEARCH REPORT

Information on patent family members

International application No.

**PCT/AU2004/000517**

This Annex lists the known "A" publication level patent family members relating to the patent documents cited in the above-mentioned international search report. The Australian Patent Office is in no way liable for these particulars which are merely given for the purpose of information.

Patent Document Cited in Search Report	Patent Family Member			
US 4573633	NONE			
WO 2000/053505	AU 31342/00	NZ 514120		
US 4371110	NONE			
US 4260098	AU 58140/80	CA 1114791	CH 648801	
	DE 3017510	DK 199580	FR 2456040	
	GB 2048829	JP 55-154238	SE 8003379	
US 2944719	NONE			
US 4114797	NONE			
US 4208007	NONE			
WO 1998/017539	BR 9712293	EP 932553		
<p style="text-align: center;">Due to data integration issues this family listing may not include 10 digit Australian applications filed since May 2001.</p> <p style="text-align: right;">END OF ANNEX</p>				